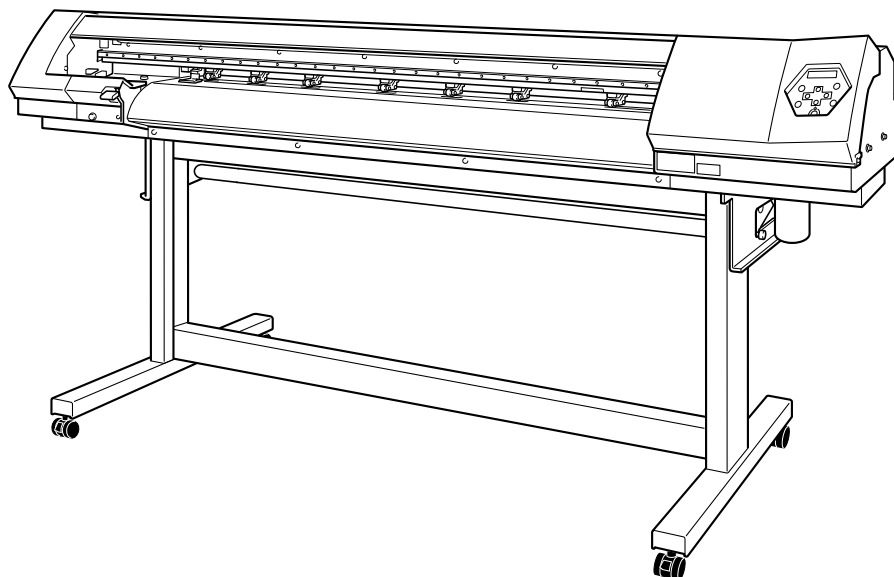

Confidential

TERMS OF USE

Users of this Service Note shall be deemed to agree with the following Terms of Use.

1. USERS

This Service Note is only for authorized persons with user ID and password issued by Roland DG Corporation.

2. PURPOSE

Authorized persons can use this Service Note only for the purposes of selling and providing to the customers maintenance service of VP-540/VP-300.

3. REUSE

Authorized persons shall not disclose, transfer, rent or distribute this Service Note to, or allow this Service Note to be used in any manner by, any third party other than authorized persons.

4. REPRODUCTION

Authorized persons shall not copy, change or alter this Service Note without permission of Roland DG Corporation.

5. EFFECT OF VIOLATION

Regardless of circumstances, we will vigorously respond to any violation hereof, through legal action.

Roland DG Corporation

Copyright © 2008 ROLAND DG CORPORATION

Contents



1 Structure & Spare Parts	
1-1 COVERS	1-1
1-2 FRAME	1-4
1-3 DRIVE UNIT	1-8
1-4 HEAD CARRIAGE (VP-540).....	1-12
1-5 HEAD CARRIAGE (VP-300).....	1-14
1-6 BASE FRAME.....	1-16
1-7 CHASSIS	1-18
1-8 PINCH ROLLER	1-19
1-9 STAND	1-20
1-10 TOOL CARRIAGE	1-21
1-11 WIPER SYSTEM	1-22
1-12 PUMP SYSTEM	1-23
1-13 INK SYSTEM	1-25
1-14 ACCESSORIES.....	1-26
2 Electrical Section	
2-1 WIRING MAP	2-1
2-2 MAIN BOARD	2-3
2-3 SERVO BOARD	2-14
2-4 CARRAGE BOARD	2-20
2-5 SUB BOARD.....	2-23
2-6 MAINTENANCE PARTS LIST	2-28
3 Replacement of Main Parts	
3-1 HEAD REPLACEMENT	3-3
3-2 WIPER REPLACEMENT	3-9
3-3 CAP TOP REPLACEMENT	3-11
3-4 TOOL CARRIAGE REPLACEMENT	3-14
3-5 CARRIAGE MOTOR REPLACEMENT	3-18
3-6 FEED MOTOR REPLACEMENT	3-22
3-7 PUMP REPLACEMENT	3-30
3-8 INK TUBE REPLACEMENT	3-37
3-9 BOARD REPLACEMENT (MAIN BOARD SW POWER SUPPLY).....	3-43
3-10 BATTERY REPLACEMENT	3-54
3-11 CARRIAGE BELT REPLACEMENT	3-57
3-12 ENCODER SCALE REPLACEMENT	3-62
3-13 GRIT ENCODER REPLACEMENT	3-64
3-14 PINCH ROLLER REPLACEMENT	3-67
3-15 CUTTER PROTECTION REPLACEMENT	3-68
4 Adjustment	
4-1 SERVICE MODE	4-1
4-2 HOW TO UPGRADE FIRMWARE/INSTALL FIRMWARE	4-15
4-3 HOW TO UPGRADE FIRMWARE OF THE NETWORK CONTROLLER.....	4-22
4-4 HEAD ALIGNMENT	4-24
4-5 LIMIT POSITION & CUT DOWN POSITION INITIALIZE	4-32
4-6 LINEAR ENCODER SETUP	4-34
4-7 FLUSHING POSITION ADJUSTMENT	4-36
4-8 CROP MARK SENSOR ADJUSTMENT	4-38
4-9 CROP-CUT ADJUSTMENT	4-40
4-10 PRINT/CUT POSITION ADJUSTMENT	4-43
4-11 CALIBRATION(FEEDING DIRECTION)	4-46
4-12 TOOL HEIGHT ADJUSTMENT	4-48
4-13 TOOL PRESSURE ADJUSTMENT	4-50
4-14 BELT TENSION ADJUSTMENT	4-53
4-15 BELT POSITION ADJUSTMENT	4-56
4-16 TAKE-UP UNIT OPERATION CHECK	4-62
5 Supplemental Information	
5-1 SPECIAL TOOLS.....	5-1
5-2 SENSOR MAP	5-2
6 Troubleshooting	
6-1 DEFECT OF PRINT QUALITY (BANDING/SCRATCHY PRINTING/BLURRED PRINTING).....	6-1
6-2 PARTICULAR COLOR IS NOT PRINTED AT ALL	6-2
6-3 SHIFTING IN PRINTING / COLOR SHIFTING.....	6-2
6-4 INK DROPS ON THE MEDIA	6-3
6-5 VERTICAL BANDING	6-3
6-6 MISSING DOT OR DEFLECTED-FIRED DOT APPEARS WHEN PERFORMING PRINTING WITH LONG DELAY	6-3
6-7 PRINT & CUT MISALIGNMENT	6-4
6-8 POOR CUTTING QUALITY(STITCH CUT, DISTORTED CUT, MISMATCHED START AND END POINTS).....	6-7
6-9 MEDIA SKEW.....	6-7
6-10 MOTOR ERROR	6-8
6-11 HEATER/DRYER TEMPERATURE DOES NOT GO UP.....	6-9
6-12 PROBLEM IN NETWORK(RIP DOES NOT RECOGNIZE THE PRINTER).....	6-9
6-13 ERROR MESSAGE	6-10
6-14 SERVICE CALL	6-10
7 Service Activities	
7-1 INSTALLATION CHECK LIST	7-1
7-2 MAINTENANCE CHECK LIST	7-12
7-3 SPACIFICATION.....	7-13

Revision Record



Revision NO.	Date	Description of Changes	Approval	Issued
0	2007.3.9	First Edition	Kato	Uchiyama
1	2007.4.25	Sect1 : Parts have been revised. Sect3 : Procedures have been revised. Sect4 : Procedures have been revised. Sect7 : Installation Check List has been revised.	Kato	Mabuchi
2	2007.6.15	Sect1 : Parts have been revised. Sect3 : Procedures have been added.	Kato	Mabuchi
3	2007.8.24	Sect3 : Procedures have been revised.	Kato	Mabuchi
4	2007.10.12	Sect3 : Procedures have been revised. Sect4 : Service Mode has been revised.	Kato	Misako
5	2007.11.20	Sect1 : Parts have been revised. Sect7 : Procedures have been revised.	Kato	Yuki
6	2008.1.29	Sect1 : Parts have been revised. 2-1 : Wiring Map Cable has been added. Sect4 : Service Mode has been revised.	Kato	Yuki

To Ensure Safe Work

About ⚠️ WARNING and ⚠️ CAUTION Notices.

 WARNING	Used for instructions intended to alert the operator to the risk of death or severe injury should the unit be used improperly.
 CAUTION	Used for instructions intended to alert the operator to the risk of injury or material damage should the unit be used improperly. * material damage refers to damage or other adverse effects caused with respect to the home and all its furnishings, as well to domestic animals or pets.

About the Symbols

	The ⚡ symbol alerts the user to important instructions or warnings. The specific meaning of the symbol is determined by the design contained within the triangle. The symbol at left means “danger of electrocution”.
	The 🚫 symbol alerts the user to items that must never be carried out (are forbidden). The specific thing that must not be done is indicated by the design contained within the circle. The symbol at left means not to touch.
	The 📌 symbol alerts the user to things that must be carried out. The specific thing that must be done is indicated by the design contained within the circle. The symbol at left means the power-cord plug must be unplugged from the outlet.

In addition to the ⚠️ **WARNING** and ⚠️ **CAUTION** symbols, the symbols shown below are also used.





: Tips and advise before the adjustment.

About the Labels Affixed to the Unit

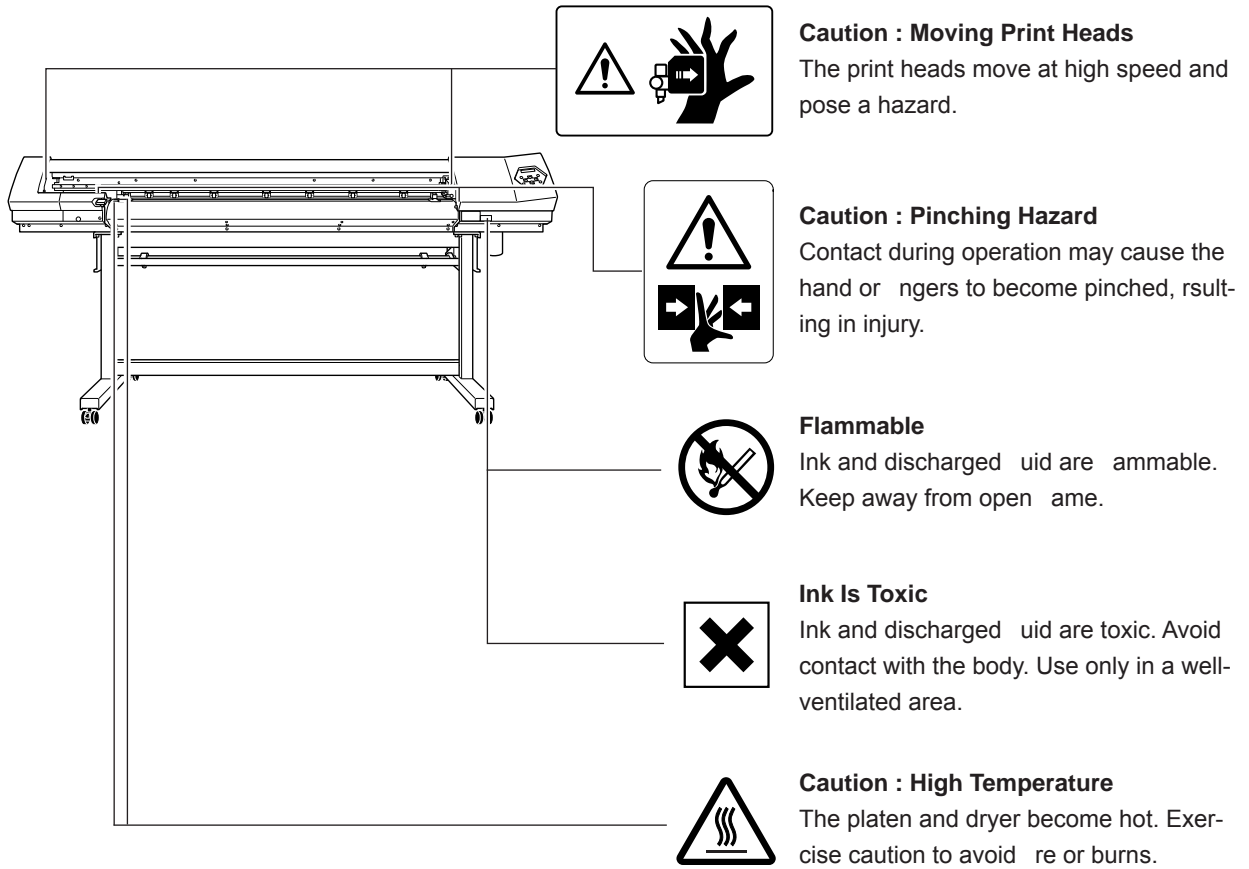
These labels are affixed to the body of this product.
The following figure describes the location.



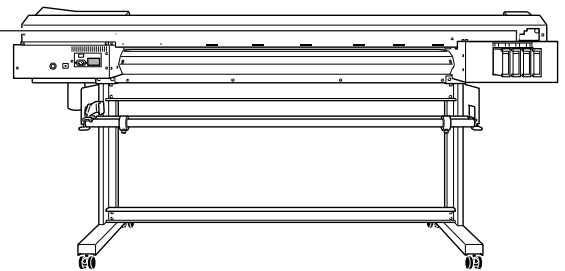

 **Flammable**
Ink and discharged fluid are flammable. Keep away from open flame.

 **Ink Is Toxic**
Ink and discharged fluid are toxic. Avoid contact with the body. Use only in a well-ventilated area.



WARNING - FOR CONTINUED PROTECTION AGAINST RISK OF FIRE, REPLACE ONLY WITH FUSE OF THE SPECIFIED TYPE AND CURRENT RATING.

ATTENTION - AFIN D'ÉVITER TOUT RISQUE D'INCENDIE, N'UTILISER QUE DES FUSIBLES DE LA TAILLE ET DU TYPE SPÉCIFIÉS.  F80L HS 

HIGH VOLTAGE, HANDLING ATTENTION

- Do not touch during power on
Electric shock, Components damage
- Do not repair. Replace power unit.
- Do not replace fuse. Can not be recovered.

高電圧、取扱注意！

- 通電中接触不可。感電、部品破損あり。
- 修理不可。基板交換のこと。
- ヒューズ交換不可。復元不能。



Electric charge.
Do not touch when power is on.



The wiring terminal untended for connection of the protective earthing conductor associated with the supply wiring.
Do not disconnect the cable of this terminal except the time of replacement.

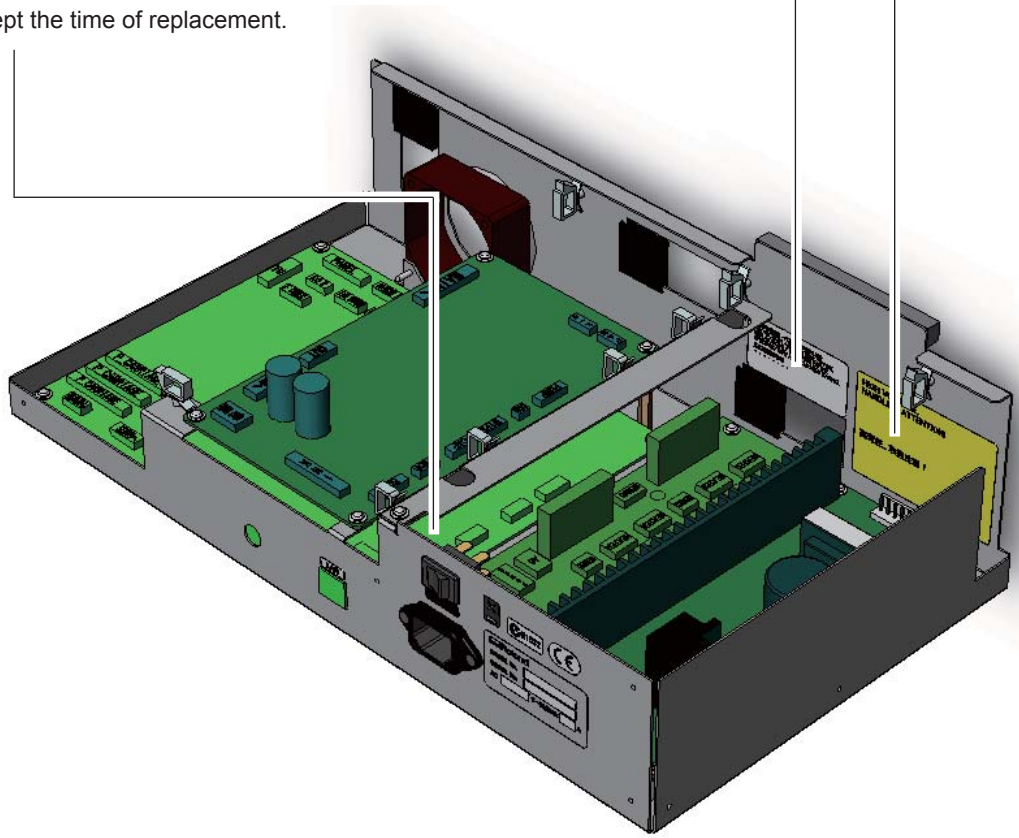

1 Structure & Spare Parts

1-1 COVER (VP-540 :Below ZW65382, VP-300 :Below ZW61509)

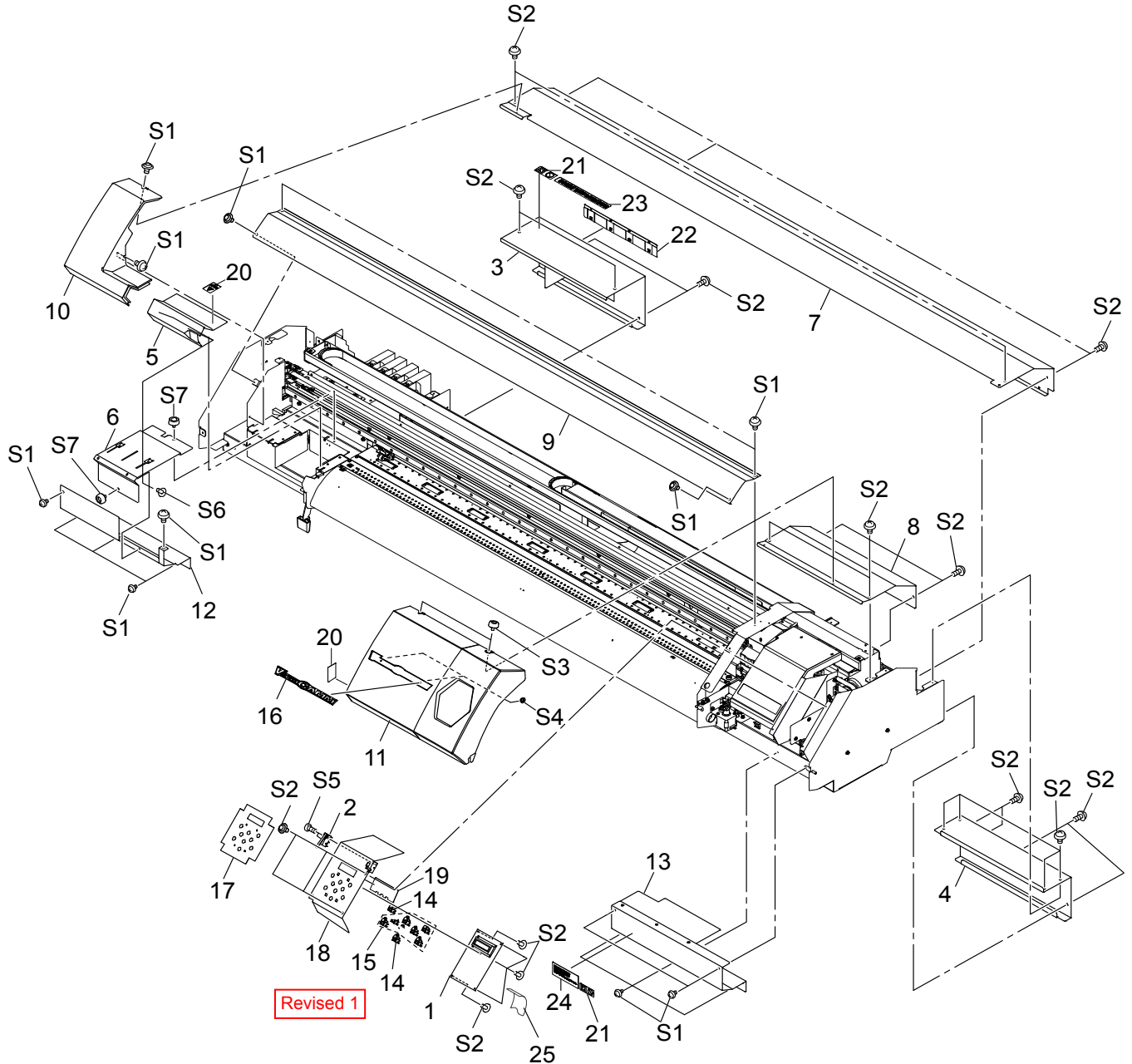

PARTS LIST -Main Parts-

	Parts No.	Parts Name
1	W700461210	ASSY,PANEL BOARD VP-540
2	23505834	CABLE-ASSY MAINT-COVER SW FJ-540
3	1000002608	COVER,INK CARTRIDGE VP-540
4	1000002633	COVER,CHASSIS VP-540
5	1000002550	COVER,MAINTENANCE INKHEAD VP-540
6	1000002620	COVER,MAINTENANCE VP-540
7	1000002676	COVER,RAIL B VP-300
	1000002624	COVER,RAIL B VP-540
8	1000002651	COVER,RAIL B-RIGHT VP-540
9	1000002150	COVER,RAIL F VP-300
	1000002146	COVER,RAIL F VP-540
10	1000002619	COVER,SIDE L VP-540
11	1000002621	COVER,SIDE R VP-540
12	1000002627	COVER,UNDER L VP-540
13	1000002628	COVER,UNDER R VP-540
14	22495102	KEY TOP,CLEAR GX-24
15	22495101	KEY TOP,WHITE GX-24
16	1000002626	LABEL,EMBLEM LOGO VERSACAMM

	Parts No.	Parts Name
17	1000002637	SHEET,PANEL VP-540
18	1000002625	STAY,PANEL VP-540
19	1000003029	SHEET,LCD VP-540
20	22535347	LABEL,CAUTION PINCH-2 #LA423
21	1000001099	LABEL,HARMFUL FIRE #LA915
22	22535441	LABEL,SET INK SP-300 #LA634
23	22535442	LABEL,USE ONLY ECO-SOL #LA635
24	22535444	LABEL,READ MANUAL #LA637
25	23475212	CABLE-CARD,24P1 600L BB

PARTS LIST -Supplemental Parts-

	Parts No.	Parts Name
S1	31289111AS	CUPSCREW SET, M4*6 NI 100 PCS.
S2	31289109AS	CUPSCREW SET,M3*4 NI 100 PCS.
S3	31139103	PLAPOINT,FE4*6 WH
S4	31149601	RING SET,PUSH-ON CS CSTW-3 100 PCS
S5	31019149	SCREW SET,BINDING M2.3*8 3CBC 100PCS
S6	31019703	SCREW,BINDING P-TIGHT M3*8 3C 100P
S7	31139104	SCREW,PLAPOINT M4*6 BK FE

1-1 COVER (VP-540 :Above ZW65383, VP-300 :Above ZW61510)

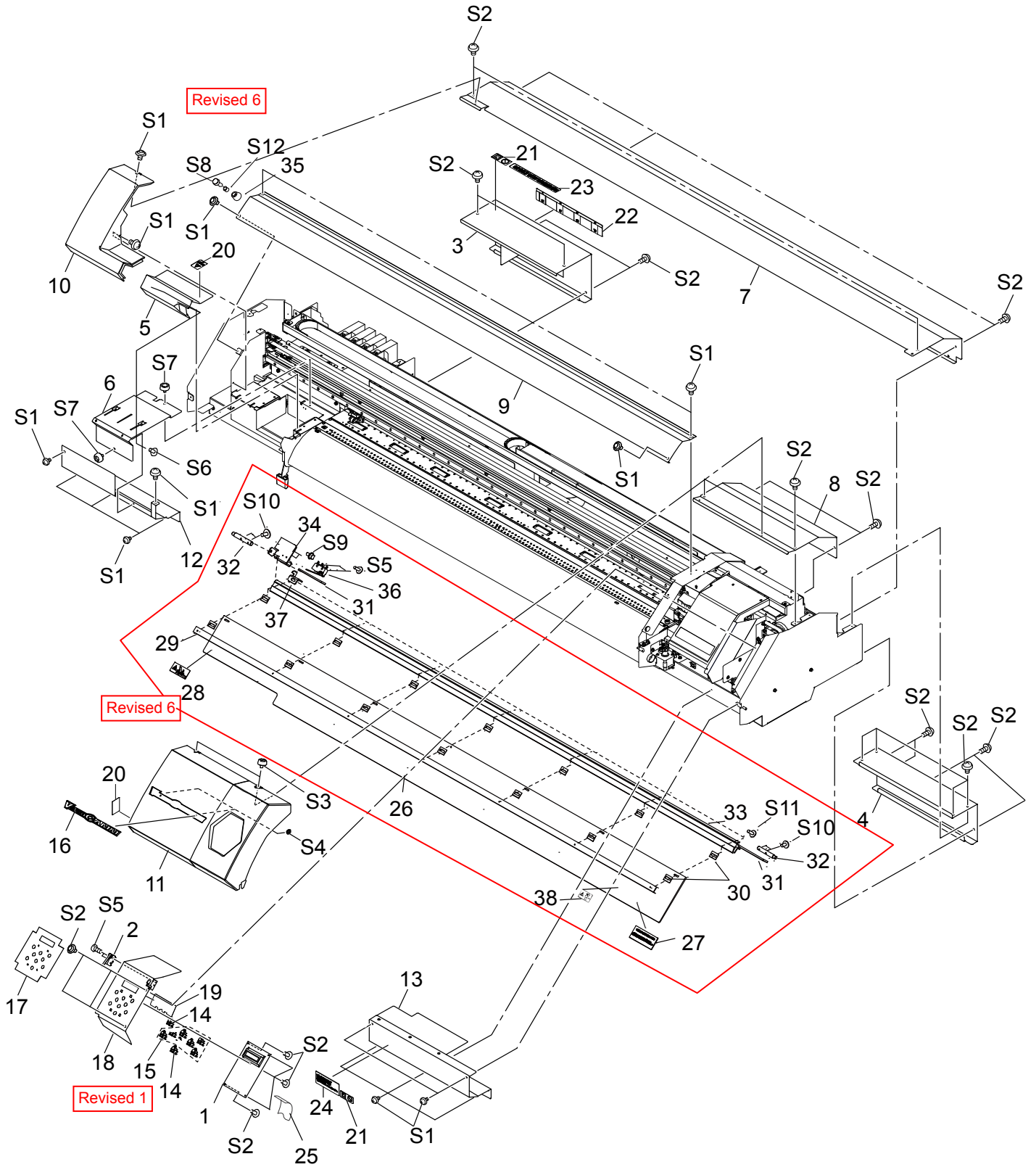

1-1 COVER (VP-540: Above ZW65383, VP-300: Above ZW61510)

PARTS LIST -Main Parts-

	Parts No.	Parts Name
1	W700461210	ASSY,PANEL BOARD VP-540
2	23505834	CABLE-ASSY MAINT-COVER SW FJ-540
3	1000002608	COVER,INK CARTRIDGE VP-540
4	1000002633	COVER,CHASSIS VP-540
5	1000002550	COVER,MAINTENANCE INKHEAD VP-540
6	1000002620	COVER,MAINTENANCE VP-540
7	1000002624	COVER,RAIL B VP-540
	1000002676	COVER,RAIL B VP-300
8	1000002651	COVER,RAIL B-RIGHT VP-540
9	1000004207	COVER,RAIL F TYPE2 VP-540
	1000004208	COVER,RAIL F TYPE2 VP-300
10	1000002619	COVER,SIDE L VP-540
11	1000002621	COVER,SIDE R VP-540
12	1000002627	COVER,UNDER L VP-540
13	1000002628	COVER,UNDER R VP-540
14	22495102	KEY TOP,CLEAR GX-24
15	22495101	KEY TOP,WHITE GX-24
16	1000002626	LABEL,EMBLEM LOGO VERSACAMM
17	1000002637	SHEET,PANEL VP-540
18	1000002625	STAY,PANEL VP-540
19	1000003029	SHEET,LCD VP-540
20	22535347	LABEL,CAUTION PINCH-2 #LA423
21	1000001099	LABEL,HARMFUL FIRE #LA915
22	22535441	LABEL,SET INK SP-300 #LA634
23	22535442	LABEL,USE ONLY ECO-SOL #LA635
24	22535444	LABEL,READ MANUAL #LA637
25	23475212	CABLE-CARD,24P1 600L BB
26	1000004197	PLATE,COVER F VP-540
	1000004204	PLATE,COVER F VP-300
27	22535390	LABEL,EMERGENCY STOP #LA496
28	22535286	LABEL,CAUTION COVER #LA265
29	1000004196	PLATE,NUT COVER F VP-540
	1000004203	PLATE,NUT COVER F VP-300
30	21425110	WASHER,COVER FJ-50
31	1000004199	PAD, STOPPER VP-540
32	1000004198	SHAFT,COVER F VP-540
33	1000004195	FRAME,COVER F VP-540
	1000004202	FRAME,COVER F VP-300
34	1000004361	COVER,INT SW VP-540
35	11879107	ABSORBER TK-12
36	13169102	COVER SW R (AVT32344)
37	1000004200	HOOK,INT SW VP-540
38	22535287	LABEL,CAUTION CARRIAGE #LA266

Revised 1

Revised 6

PARTS LIST -Supplemental Parts-

	Parts No.	Parts Name
S1	31289111AS	CUPSCREW SET, M4*6 NI 100 PCS.
S2	31289109AS	CUPSCREW SET,M3*4 NI 100 PCS.
S3	31139103	PLAPOINT,FE4*6 WH
S4	31149601	RING SET,PUSH-ON CS CSTW-3 100 PCS
S5	31019149	SCREW SET,BINDING M2.3*8 3CBC 100PCS
S6	31019703	SCREW,BINDING P-TIGHT M3*8 3C 100P
S7	31139104	SCREW,PLAPOINT M4*6 BK FE
S8	31049106AS	SCREW SET,CAP M3*8 3CBC 20 PCS
S9	31049169AS	SCREW SET,CAP M4*8 3CBC+PW 20PCS
S10	31289102AS	CUPSCREW SET,M3*6 NI 50 PCS.
S11	31289112AS	CUPSCREW SET,M3*10 NI 100 PCS.
S12	31029816AS	BUSH SET,ROLL 3*4 100 3C PCS.

Revised 6

1-2 FRAME (VP-540:Below ZW65382, VP-300:Below ZW61509)

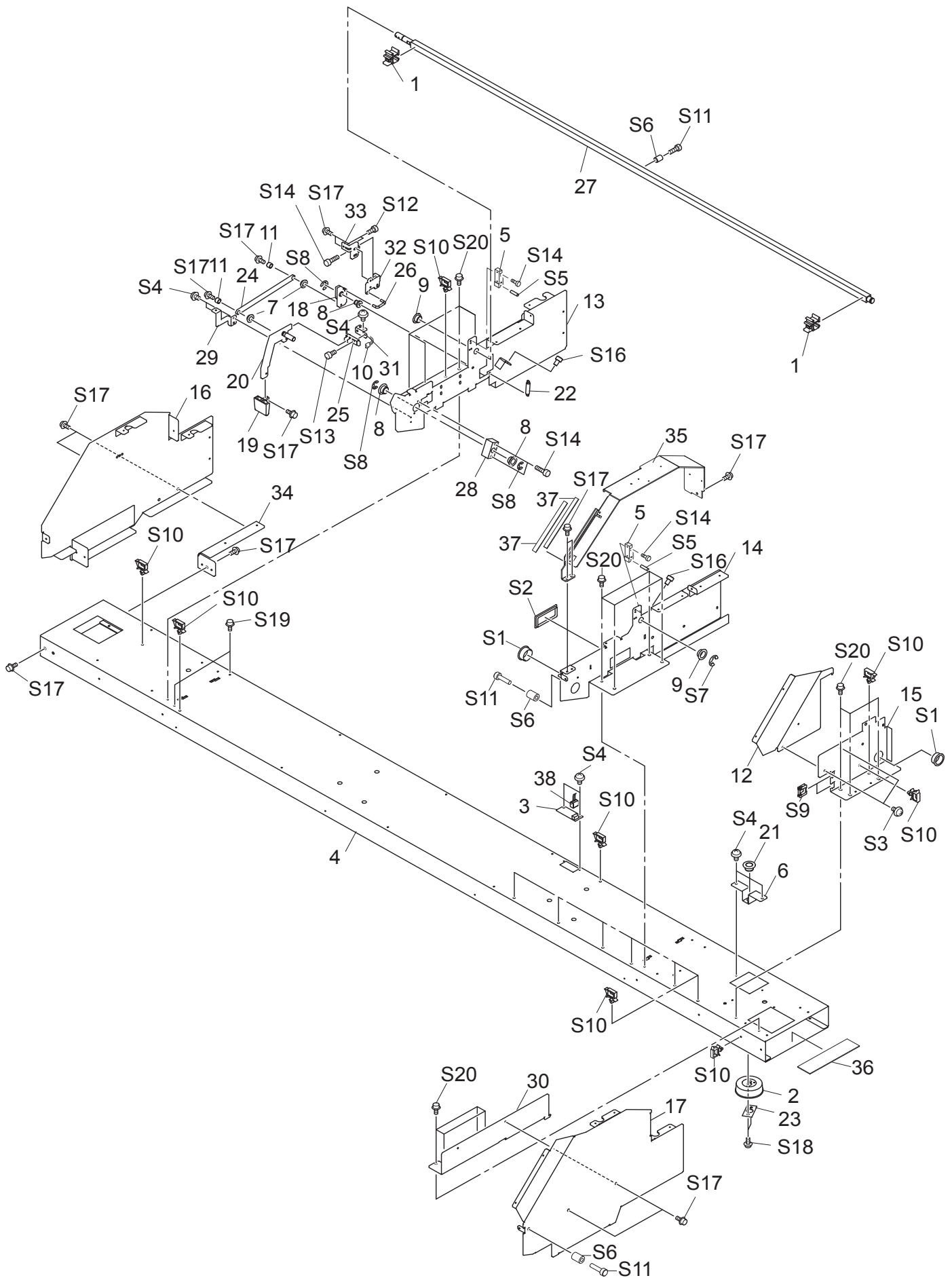

1-2 FRAME (VP-540:Below ZW65382, VP-300:Below ZW61509)

PARTS LIST -Main Parts-

	Parts No.	Parts Name
1	21905192	ADAPTER,CLAMP MEDIA SP-540V
2	7520501000	ASSY,CAP BOTTLE 2 FJ-52
3	W700461240	ASSY,FAN JUNCTION BOARD VP-540
4	1000002653	BASE,BOTTOM VP-300
	1000002527	BASE,BOTTOM VP-540
5	1000002589	BASE,RAIL VP-540
6	21985140	BRACKET,INK CATCH TANK SP-540V
7	12159573	BUSH,80F-0603
8	12159563	BUSH,80F-1006
9	12159508	BUSH,SHAFT OILES 80F-1206
10	1000002176	CABLE-ASSY,PINCH U/D SENSOR VP-540
11	21745109	COLLAR,LEVER FJ-540
12	1000002630	COVER,SCAN MOTOR VP-540
13	1000002528	FRAME,MIDDLE L VP-540
14	1000002529	FRAME,MIDDLE R VP-540
15	1000002548	FRAME,SCAN MOTOR VP-540
16	1000002518	FRAME,SIDE L VP-540
17	1000002545	FRAME,SIDE R VP-540
18	22305101	GUIDE,LEVER SP-300
19	22485104	KNOB FJ-50
20	1000002556	LEVER,CAM PINCH VP-540
21	22155763	OILES BUSH 80F-0806
22	22175105	PINCH ROLL SPRING
23	22055474	PLATE,INK CATCH TANK FJ-52
24	1000002609	PLATE,LEVER LINK VP-540
25	15229506	SENSOR INTERRUPTER,GP1A05A5
26	22145393	SHAFT,JOINT PNC-960
27	22295270	SHAFT,SQUARE SP-300
	1000002526	SHAFT,SQUARE VP-540
28	22035196	STAND,LEVER SP-300
29	1000002629	STAY,COVER UNDER VP-540
30	1000002558	STAY,FRAME SIDE R VP-540
31	1000002555	STAY,LEVER SENSOR VP-540
32	1000002631	STAY,PINCH LEVER ADJUST VP-540
33	1000002551	STAY,PINCH LEVER VP-540
34	1000002569	STAY,SUPPORT INKCARTRIDGE VP-540
35	1000002607	SUPPORT,FRAME R VP-540
36	1000003088	PAD,BASE BOTTOM VP-540
37	1000003087	PAD,SUPPORT FRAME R VP-540
38	1000002168	CABLE-ASSY,FAN VP-540

PARTS LIST -Supplemental Parts-

	Parts No.	Parts Name
S1	31029101	BUSH,NB-19
S2	31029106	BUSH,SQUARE SB-6025
S3	31289111AS	CUPSCREW SET, M4*6 NI 100 PCS.
S4	31289109AS	CUPSCREW SET,M3*4 NI 100 PCS.
S5	31119904	PIN,SPRING 2.5*8 SUS STRAIGHT 50 PCS
S6	31129101	PIPE SET,POLYCA 3*6*8 20PCS
S7	31149706AS	RING SET,E-RING ETW-10 SUS 20 PCS
S8	31149705	RING SET,E-RING ETW-7 SUS 50PCS
S9	31409702	SADDLE SET,LOCKING WIRE LES-1010 20P
S10	31409801AS	SADDLE,LOCKING WIRE LWS-0711Z 20P
S11	31049171AS	SCREW SET,CAP M3*12 NI 50 PCS.
S12	31049142AS	SCREW SET,CAP M3*6 NI MEC 20 PCS
S13	31049173AS	SCREW SET,CAP M4*10 NI 50 PCS.
S14	31049137AS	SCREW SET,CAP M4*25 3CBC 20 PCS
S16	31799107	SCREW SET,CAP M4*6 NI 20PCS
S17	31049169AS	SCREW SET,CAP M4*8 3CBC+PW 20PCS
S18	31239125AS	SCREW SET,W-SEMS M3*8 SUS 50 PCS.
S19	31179106	SCREW,JACK UP SP-540V
S20	31069104	SCREW,CAP M4*6+FL NI

1-2 FRAME (VP-540: Above ZW65383, VP-300: Above ZW61510)

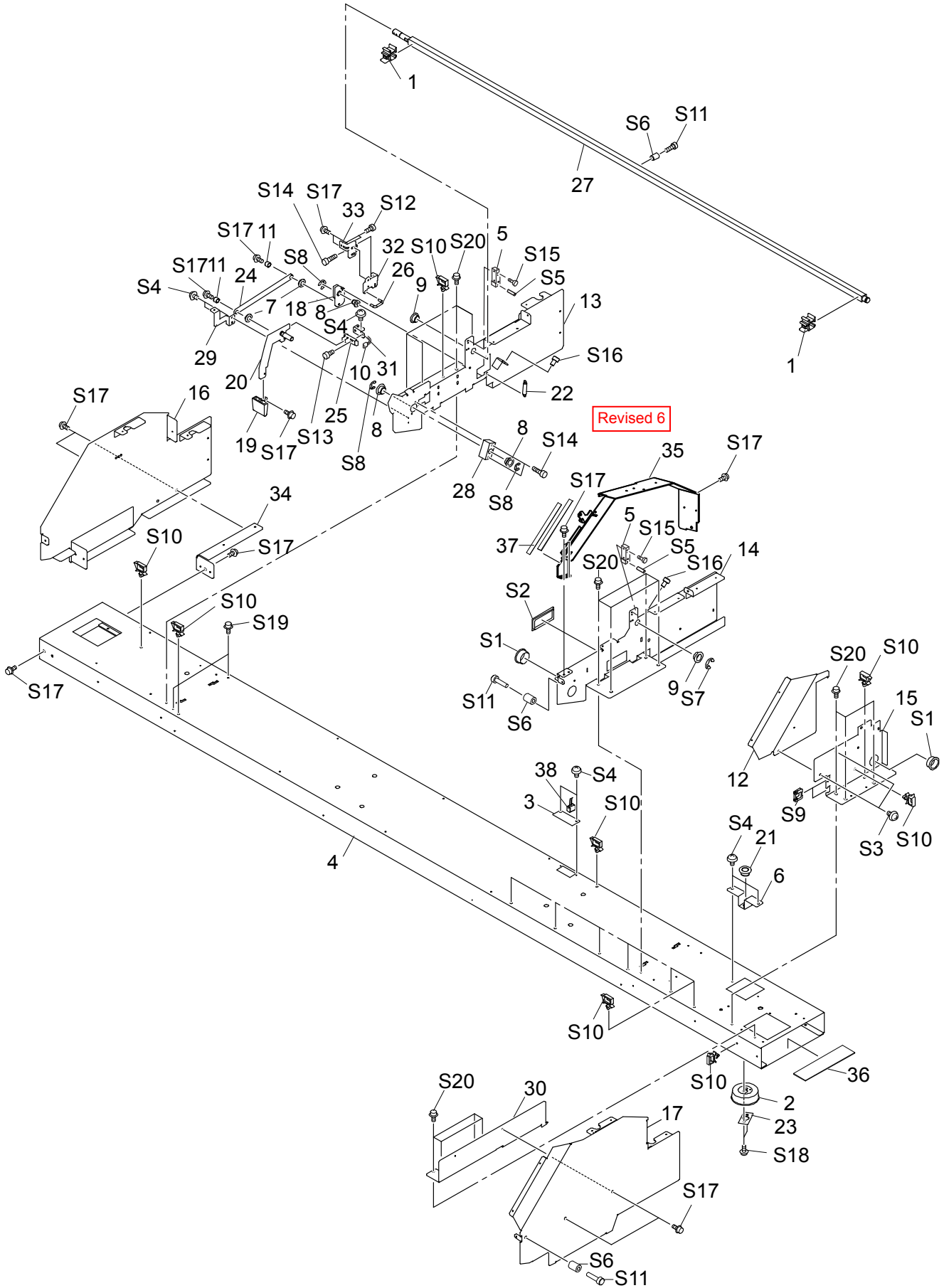

1-2 FRAME (VP-540: Above ZW65383, VP-300: Above ZW61510)

PARTS LIST -Main Parts-

	Parts No.	Parts Name
1	21905192	ADAPTER,CLAMP MEDIA SP-540V
2	7520501000	ASSY,CAP BOTTLE 2 FJ-52
3	W700461240	ASSY,FAN JUNCTION BOARD VP-540
4	1000002653	BASE,BOTTOM VP-300
	1000002527	BASE,BOTTOM VP-540
5	1000002589	BASE,RAIL VP-540
6	21985140	BRACKET,INK CATCH TANK SP-540V
7	12159573	BUSH,80F-0603
8	12159563	BUSH,80F-1006
9	12159508	BUSH,SHAFT OILES 80F-1206
10	1000002176	CABLE-ASSY,PINCH U/D SENSOR VP-540
11	21745109	COLLAR,LEVER FJ-540
12	1000002630	COVER,SCAN MOTOR VP-540
13	1000002528	FRAME,MIDDLE L VP-540
14	1000002529	FRAME,MIDDLE R VP-540
15	1000002548	FRAME,SCAN MOTOR VP-540
16	1000002518	FRAME,SIDE L VP-540
17	1000002545	FRAME,SIDE R VP-540
18	22305101	GUIDE,LEVER SP-300
19	22485104	KNOB FJ-50
20	1000002556	LEVER,CAM PINCH VP-540
21	22155763	OILES BUSH 80F-0806
22	22175105	PINCH ROLL SPRING
23	22055474	PLATE,INK CATCH TANK FJ-52
24	1000002609	PLATE,LEVER LINK VP-540
25	15229506	SENSOR INTERRUPTER,GP1A05A5
26	22145393	SHAFT,JOINT PNC-960
27	22295270	SHAFT,SQUARE SP-300
	1000002526	SHAFT,SQUARE VP-540
28	22035196	STAND,LEVER SP-300
29	1000002629	STAY,COVER UNDER VP-540
30	1000002558	STAY,FRAME SIDE R VP-540
31	1000002555	STAY,LEVER SENSOR VP-540
32	1000002631	STAY,PINCH LEVER ADJUST VP-540
33	1000002551	STAY,PINCH LEVER VP-540
34	1000002569	STAY,SUPPORT INKCARTRIDGE VP-540
35	1000004193	SUPPORT,FRAME R TYPE2 VP-540 Revised 6
36	1000003088	PAD,BASE BOTTOM VP-540
37	1000003087	PAD,SUPPORT FRAME R VP-540
38	1000002168	CABLE-ASSY,FAN VP-540

PARTS LIST -Supplemental Parts-

	Parts No.	Parts Name
S1	31029101	BUSH,NB-19
S2	31029106	BUSH,SQUARE SB-6025
S3	31289111AS	CUPSCREW SET, M4*6 NI 100 PCS.
S4	31289109AS	CUPSCREW SET,M3*4 NI 100 PCS.
S5	31119904	PIN,SPRING 2.5*8 SUS STRAIGHT 50 PCS
S6	31129101	PIPE SET,POLYCA 3*6*8 20PCS
S7	31149706AS	RING SET,E-RING ETW-10 SUS 20 PCS
S8	31149705	RING SET,E-RING ETW-7 SUS 50PCS
S9	31409702	SADDLE SET,LOCKING WIRE LES-1010 20P
S10	31409801AS	SADDLE,LOCKING WIRE LWS-0711Z 20P
S11	31049171AS	SCREW SET,CAP M3*12 NI 50 PCS.
S12	31049142AS	SCREW SET,CAP M3*6 NI MEC 20 PCS
S13	31049173AS	SCREW SET,CAP M4*10 NI 50 PCS.
S14	31049137AS	SCREW SET,CAP M4*25 3CBC 20 PCS
S16	31799107	SCREW SET,CAP M4*6 NI 20PCS
S17	31049169AS	SCREW SET,CAP M4*8 3CBC+PW 20PCS
S18	31239125AS	SCREW SET,W-SEMS M3*8 SUS 50 PCS.
S19	31179106	SCREW,JACK UP SP-540V
S20	31069104	SCREW,CAP M4*6+FL NI

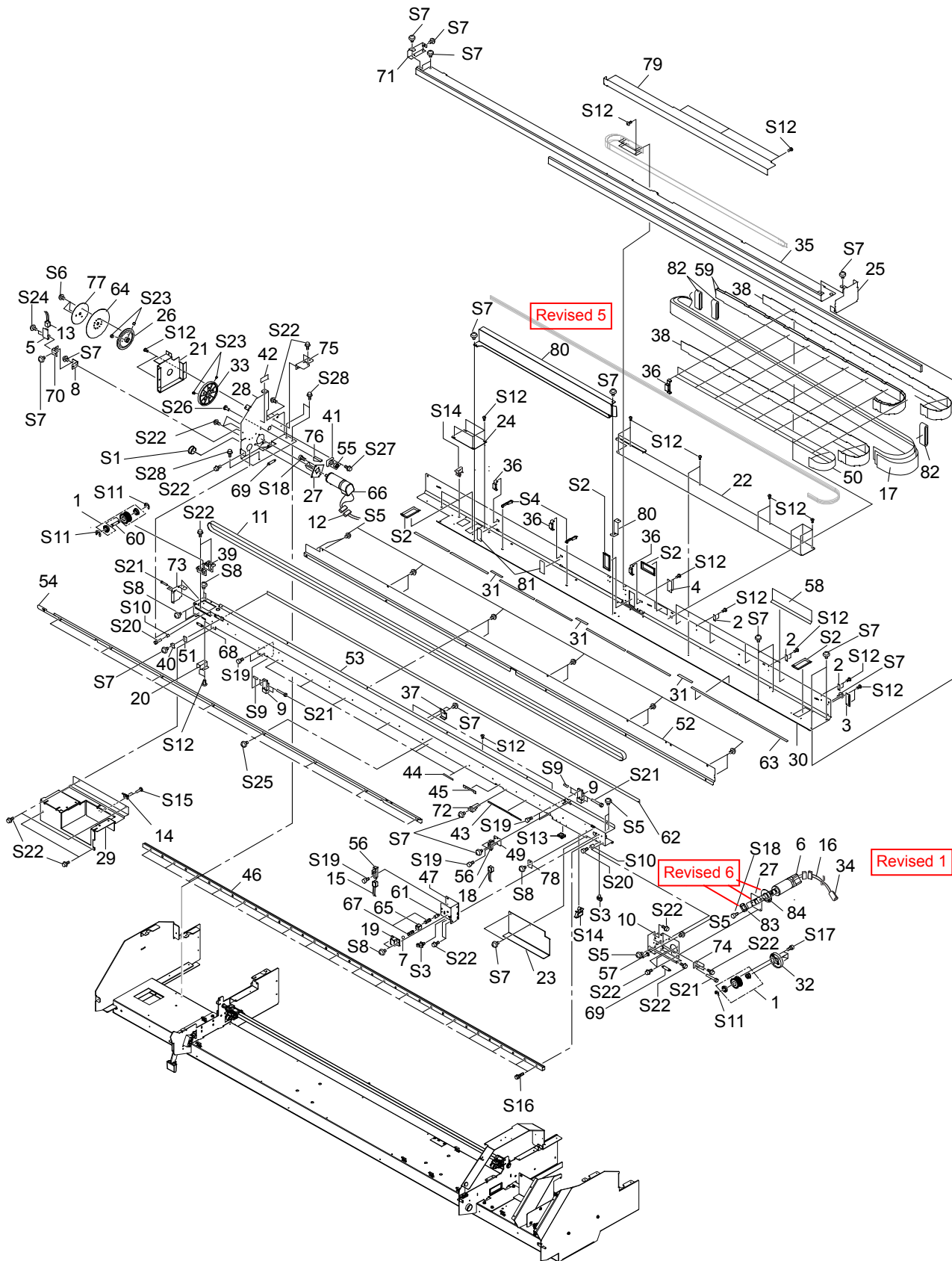

1-3 DRIVE UNIT (VP-540:Below ZW65382, VP-300:Below ZW61509)

PARTS LIST -Main Parts-

	Parts No.	Parts Name
1	6700469030	ASSY,PULLEY VP-540
2	W700461290	ASSY,FLEX1 VP-540
3	W7004612A0	ASSY,FLEX2 VP-540
4	W7004612B0	ASSY,FLEX3 VP-540
5	W700461260	ASSY,GRIT ENCODER BOARD VP-540
6	6700469020	ASSY,SCAN MOTOR VP-540
7	11869103	BALL,4MM
8	1000002605	BASE,G-ENCODER SENSOR VP-540
9	1000002589	BASE,RAIL VP-540
10	1000002533	BASE,SCAN DRIVE VP-540
11	1000002671	BELT,100S2M1539LW-C
	1000002547	BELT,150S2M2153LW-C
12	23415124	CABLE-ASSY,G-MOTOR SP-300
13	1000002169	CABLE-ASSY,GRIT ENCODER VP-540
14	23415114	CABLE-ASSY,MAINT-COVER SW SP-300
15	1000002178	CABLE-ASSY,PRI-CAR ORG VP-540
16	1000002188	CABLE-ASSY,SCAN MOTOR VP-540
17	23475213	CABLE-CARD,36P1 2000L BB
	23475240	CABLE-CARD,36P1 2670L BB HIGH-V
18	1000002167	CABLE-ASSY,CUT-CAR ORG VP-540
19	21365103	CASE,LOCK CJ-70
20	1000002646	COVER,ENCODER VP-540
21	1000002592	COVER,FEED GEAR VP-540
22	1000002711	COVER,INK CARTRIDGE FLEX VP-300
	1000002708	COVER,INK CARTRIDGE FLEX VP-540
23	1000002647	COVER,INNER VP-540
24	1000003037	COVER,JUNCTION BOARD VP-540
25	1000002710	COVER,RAIL SIDE VP-540
26	1000002593	FLANGE,GRIT-ENCORDER VP-540
27	1000003823	FLANGE,MOTOR SCAN VP-540 Revised 6
28	1000002552	FRAME,FEED MOTOR VP-540
29	1000002549	FRAME,SUPPORT AUTO CUTTER VP-540
30	1000002660	FRAME,SUPPORT RAIL VP-300
	1000002546	FRAME,SUPPORT RAIL VP-540
31	1000003086	FILTER(E),RAIL SHIELD VP-540
32	1000001905	GEAR,H187S20(B8)
33	21685128	GEAR,H300 S10(B6C16POM)
34	1000003084	FILTER(E),SFT-36SN Revised 1
35	1000002673	GUIDE,CUT CABLE VP-300
	1000002616	GUIDE,CUT CABLE VP-540
36	1000003293	GUIDE,TUBE TYPE3 VP-540 Revised 2
37	1000002603	HOLDER,BACKUP SHAFTSQUARE VP-540
38	1000002666	HOLDER,CABLE VP-300
	1000002562	HOLDER,CABLE VP-540
39	1000001555	HOLDER,IDLE PULLEY XC-540
40	21655131	HOLDER,LINEAR SCALE CJ-70
41	22115121	HOUSING,R-BEARING FRAME FJ-540
42	22535287	LABEL,CAUTION CARRIAGE #LA266
43	1000002971	LABEL,G-ROLLER 170 VP-540 #LA978
44	1000002970	LABEL,G-ROLLER 50 VP-540 #LA977
45	1000002685	LABEL,PINCH ROLL VP-540#LA968
46	1000002196	L-BEARING,SSR15XW1GG/W2GE+1440L
	1000002145	L-BEARING,SSR15XW1GG/W2GE+2050L
47	1000002535	LOCK,STAY VP-540
49	1000002581	PLATE,CUT ORIGIN VP-540
50	1000002675	PLATE,HOLDER CABLE VP-300
	1000002612	PLATE,HOLDER CABLE VP-540
51	22055316	PLATE,LINEAR SCALE CJ-70
52	1000002672	PLATE,RAIL REAR VP-300
	1000002615	PLATE,RAIL REAR VP-540
53	1000002658	RAIL,GUIDE VP-300
	1000002525	RAIL,GUIDE VP-540
54	1000002659	RAIL,LINEAR SCALE VP-300
	1000002543	RAIL,LINEAR SCALE VP-540

PARTS LIST -Main Parts-

	Parts No.	Parts Name
55	22175870	R-BEARING JIS 6800ZZ(B7)
56	15229506	SENSOR INTERRUPTER,GP1A05A5
57	1000001480	SHAFT,DRIVE PULLEY XC-540
58	1000003089	SHEET,FRAME SUPPORT RAIL VP-540
59	1000003097	SHEET,HOLDER CABLE VP-300 Revised 2
	1000003096	SHEET,HOLDER CABLE VP-540
60	1000001479	SHAFT,IDLE PULLEY XC-540
61	22295117	SHAFT,LOCK CJ-70
62	1000002665	SHEET,LINEAR SCALE VP-300
	1000002544	SHEET,LINEAR SCALE VP-540
63	1000002712	SHEET,RAIL UNDER VP-300 Revised 1
	1000002709	SHEET,RAIL UNDER VP-540
64	1000002162	SHEET,ROTARY DISK SLIT 360LPI
65	22185101	SLIDER,LOCK CJ-70
66	7876709020	ASSY,FEED MOTOR SP-540V
67	22175134	SPRING,A CJ-70
68	22175122	SPRING,BACKUP PNC-960
69	22175157	SPRING,C P-ROLLER CM-500
70	1000002596	STAY,G-ENCODER SENSOR VP-540
71	1000002602	STAY,GUIDE FLEX VP-540
72	22715469	STAY,HOLD SHAFT SQUARE SP-500
73	1000002597	STAY,RAILGUIDE L VP-540
74	1000002534	STAY,SHAFT DRIVE PULLEY VP-540
75	1000002554	STAY,SUPPORT RAIL L VP-540
76	22135346	STOPPER,CAM CM-500 Revised 1
77	1000002594	STOPPER,GRIT-ENCORDER VP-540
78	22135439	STOPPER,LINEAR SCALE FJ-540
79	1000003036	SUPPORT, CABLE
80	1000004142	SUPPORT,GUIDE CABLE TYPE2 VP-540 Revised 5
81	1000003151	PAD,GUIDE TUBE VP-540
82	12399352	FILTER(E) FRC-45-12-6.5 Revised 2
83	1000003821	SPACER,FLANGE VP-540
84	1000003822	BASE,FLANGE VP-540 Revised 6

PARTS LIST -Supplemental Parts-

	Parts No.	Parts Name
S1	31029101	BUSH,NB-19
S2	31029106	BUSH,SQUARE SB-6025
S3	31329501AS	CLAMP SET,PUSH MOUNT RT30SSF5 20P
S4	3000000033	CLAMP,WIRE PLESS RFC-45VO
S5	31289111AS	CUPSCREW SET, M4*6 NI 100 PCS.
S6	31289112AS	CUPSCREW SET,M3*10 NI 100 PCS.
S7	31289109AS	CUPSCREW SET,M3*4 NI 100 PCS.
S8	31289102AS	CUPSCREW SET,M3*6 NI 50 PCS.
S9	31119904	PIN,SPRING 2.5*8 SUS STRAIGHT 50 PCS
S10	31129102	PIPE SET,POLYCA 4*8*10 20PCS
S11	31149704AS	RING SET,E-RING ETW-6 SUS 100 PCS
S12	31299102AS	RIVET SET,NYLON P2655B 20 PCS.
S13	31409702	SADDLE SET,LOCKING WIRE LES-1010 20P
S14	31409801AS	SADDLE,LOCKING WIRE LWS-0711Z 20P
S15	31019149	SCREW SET,BINDING M2.3*8 3CBC 100PCS
S16	31049155AS	SCREW SET,CAP M3*12 BC+PW 20 PCS.
S17	31049171AS	SCREW SET,CAP M3*12 NI 50 PCS.
S18	31049170AS	SCREW SET,CAP M3*8 NI 50 PCS.
S19	31049173AS	SCREW SET,CAP M4*10 NI 50 PCS.
S20	31049174AS	SCREW SET,CAP M4*15 NI 20 PCS.
S21	31049137AS	SCREW SET,CAP M4*25 3CBC 20 PCS
S22	31049169AS	SCREW SET,CAP M4*8 3CBC+PW 20PCS
S23	31199701AS	SCREW SET,SET WP M3*3 NI 20 PCS
S24	31229103AS	SCREW SET,TRUSS M2*6 NI 100 PCS
S25	31239103AS	SCREW SET,W-SEMS M3*8 NI+PW 50 PCS
S26	31019703	SCREW,BINDING P-TIGHT M3*8 3C 100P
S27	31049117	SCREW,CAP M4*12 NI+PW 4*9*0.8 20PCS
S28	31069104	SCREW,CAP M4*6+FL NI

1-3 DRIVE UNIT (VP-540 : Above ZW65383, VP-300 : Above ZW61510)

Revised 2

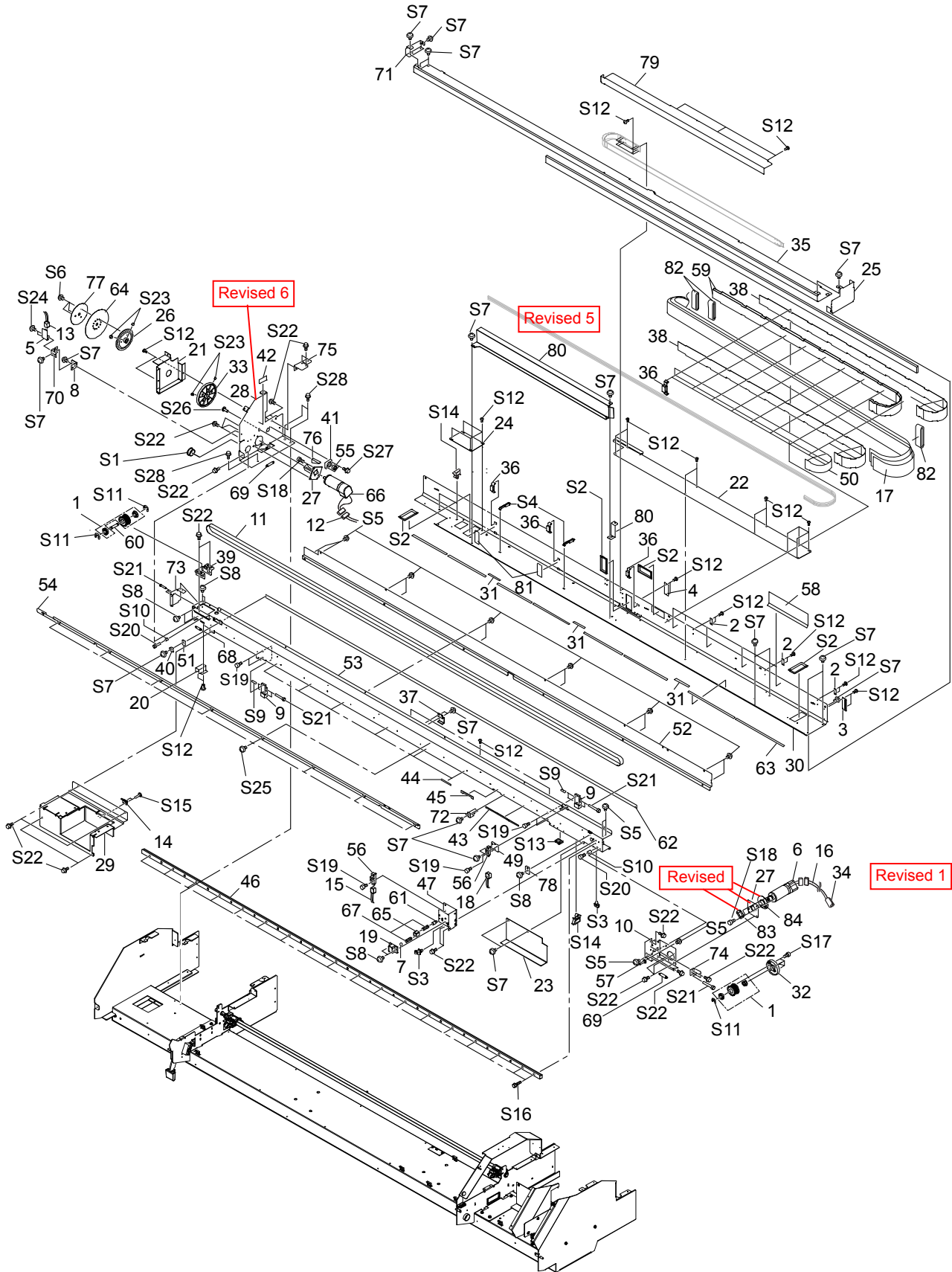

1-3 DRIVE UNIT (VP-540 :Above ZW65383, VP-300 :Above ZW61510)

PARTS LIST -Main Parts-

	Parts No.	Parts Name	
1	6700469030	ASSY,PULLEY VP-540	
2	W700461290	ASSY,FLEX1 VP-540	
3	W7004612A0	ASSY,FLEX2 VP-540	
4	W7004612B0	ASSY,FLEX3 VP-540	
5	W700461260	ASSY,GRIT ENCODER BOARD VP-540	
6	6700469020	ASSY,SCAN MOTOR VP-540	
7	11869103	BALL,4MM	
8	1000002605	BASE,G-ENCODER SENSOR VP-540	
9	1000002589	BASE,RAIL VP-540	
10	1000002533	BASE,SCAN DRIVE VP-540	
11	1000002671	BELT,100S2M1539LW-C	
	1000002547	BELT,150S2M2153LW-C	
12	23415124	CABLE-ASSY,G-MOTOR SP-300	
13	1000002169	CABLE-ASSY,GRIT ENCODER VP-540	
14	23415114	CABLE-ASSY,MAINT-COVER SW SP-300	
15	1000002178	CABLE-ASSY,PRI-CAR ORG VP-540	
16	1000002188	CABLE-ASSY,SCAN MOTOR VP-540	
17	23475213	CABLE-CARD,36P1 2000L BB	
	23475240	CABLE-CARD,36P1 2670L BB HIGH-V	
18	1000002167	CABLE-ASSY,CUT-CAR ORG VP-540	
19	21365103	CASE,LOCK CJ-70	
20	1000002646	COVER,ENCODER VP-540	
21	1000002592	COVER,FEED GEAR VP-540	
22	1000002711	COVER,INK CARTRIDGE FLEX VP-300	
	1000002708	COVER,INK CARTRIDGE FLEX VP-540	
23	1000002647	COVER,INNER VP-540	
24	1000003037	COVER,JUNCTION BOARD VP-540	
25	1000002710	COVER,RAIL SIDE VP-540	
26	1000002593	FLANGE,GRIT-ENCORDER VP-540	
27	1000003823	FLANGE,MOTOR SCAN VP-540	Revised 6
28	1000004194	FRAME,FEED MOTOR VP-540_01	Revised 6
29	1000002549	FRAME,SUPPORT AUTO CUTTER VP-540	
30	1000002660	FRAME,SUPPORT RAIL VP-300	
	1000002546	FRAME,SUPPORT RAIL VP-540	
31	1000003086	FILTER(E),RAIL SHIELD VP-540	
32	1000001905	GEAR,H187S20(B8)	
33	21685128	GEAR,H300 S10(B6C16POM)	
34	1000003084	FILTER(E),SFT-36SN	Revised 1
35	1000002673	GUIDE,CUT CABLE VP-300	
	1000002616	GUIDE,CUT CABLE VP-540	
36	1000003293	GUIDE,TUBE TYPE3 VP-540	Revised 2
37	1000002603	HOLDER,BACKUP SHAFTSQUARE VP-540	
38	1000002666	HOLDER,CABLE VP-300	
	1000002562	HOLDER,CABLE VP-540	
39	1000001555	HOLDER,IDLE PULLEY XC-540	
40	21655131	HOLDER,LINEAR SCALE CJ-70	
41	22115121	HOUSING,R-BEARING FRAME FJ-540	
42	22535287	LABEL,CAUTION CARRIAGE #LA266	
43	1000002971	LABEL,G-ROLLER 170 VP-540 #LA978	
44	1000002970	LABEL,G-ROLLER 50 VP-540 #LA977	
45	1000002685	LABEL,PINCH ROLL VP-540#LA968	
46	1000002196	L-BEARING,SSR15XW1GGE/W2GE+1440L	
	1000002145	L-BEARING,SSR15XW1GGE/W2GE+2050L	
47	1000002535	LOCK,STAY VP-540	
49	1000002581	PLATE,CUT ORIGIN VP-540	
50	1000002675	PLATE,HOLDER CABLE VP-300	
50	1000002612	PLATE,HOLDER CABLE VP-540	
51	22055316	PLATE,LINEAR SCALE CJ-70	
52	1000002672	PLATE,RAIL REAR VP-300	
	1000002615	PLATE,RAIL REAR VP-540	
53	1000002658	RAIL,GUIDE VP-300	
	1000002525	RAIL,GUIDE VP-540	
54	1000002659	RAIL,LINEAR SCALE VP-300	
	1000002543	RAIL,LINEAR SCALE VP-540	

PARTS LIST -Main Parts-

	Parts No.	Parts Name	
55	22175870	R-BEARING JIS 6800ZZ(B7)	
56	15229506	SENSOR INTERRUPTER,GP1A05A5	
57	1000001480	SHAFT,DRIVE PULLEY XC-540	
58	1000003089	SHEET,FRAME SUPPORT RAIL VP-540	
59	1000003097	SHEET,HOLDER CABLE VP-300	Revised 2
	1000003096	SHEET,HOLDER CABLE VP-540	
60	1000001479	SHAFT,IDLE PULLEY XC-540	
61	22295117	SHAFT,LOCK CJ-70	
62	1000002665	SHEET,LINEAR SCALE VP-300	
	1000002544	SHEET,LINEAR SCALE VP-540	
63	1000002712	SHEET,RAIL UNDER VP-300	Revised 1
	1000002709	SHEET,RAIL UNDER VP-540	
64	1000002162	SHEET,ROTARY DISK SLIT 360LPI	
65	22185101	SLIDER,LOCK CJ-70	
66	7876709020	ASSY,FEED MOTOR SP-540V	
67	22175134	SPRING,A CJ-70	
68	22175122	SPRING,BACKUP PNC-960	
69	22175157	SPRING,C P-ROLLER CM-500	
70	1000002596	STAY,G-ENCODER SENSOR VP-540	
71	1000002602	STAY,GUIDE FLEX VP-540	
72	22715469	STAY,HOLD SHAFT SQUARE SP-500	
73	1000002597	STAY,RAILGUIDE L VP-540	
74	1000002534	STAY,SHAFT DRIVE PULLEY VP-540	
75	1000002554	STAY,SUPPORT RAIL L VP-540	
76	22135346	STOPPER,CAM CM-500	Revised 1
77	1000002594	STOPPER,GRIT-ENCORDER VP-540	
78	22135439	STOPPER,LINEAR SCALE FJ-540	
79	1000003036	SUPPORT, CABLE	
80	1000004142	SUPPORT,GUIDE CABLE TYPE2 VP-540	Revised 5
81	1000003151	PAD,GUIDE TUBE VP-540	
82	12399352	FILTER(E) FRC-45-12-6.5	Revised 2
83	1000003821	SPACER,FLANGE VP-540	
84	1000003822	BASE,FLANGE VP-540	Revised 6

PARTS LIST -Supplemental Parts-

	Parts No.	Parts Name
S1	31029101	BUSH,NB-19
S2	31029106	BUSH,SQUARE SB-6025
S3	31329501AS	CLAMP SET,PUSH MOUNT RT30SSF5 20P
S4	3000000033	CLAMP,WIRE PLESS RFC-45VO
S5	31289111AS	CUPSCREW SET, M4*6 NI 100 PCS.
S6	31289112AS	CUPSCREW SET,M3*10 NI 100 PCS.
S7	31289109AS	CUPSCREW SET,M3*4 NI 100 PCS.
S8	31289102AS	CUPSCREW SET,M3*6 NI 50 PCS.
S9	31119904	PIN,SPRING 2.5*8 SUS STRAIGHT 50 PCS
S10	31129102	PIPE SET,POLYCA 4*8*10 20PCS
S11	31149704AS	RING SET,E-RING ETW-6 SUS 100 PCS
S12	31299102AS	RIVET SET,NYLON P2655B 20 PCS.
S13	31409702	SADDLE SET,LOCKING WIRE LES-1010 20P
S14	31409801AS	SADDLE,LOCKING WIRE LWS-0711Z 20P
S15	31019149	SCREW SET,BINDING M2.3*8 3CBC 100PCS
S16	31049155AS	SCREW SET,CAP M3*12 BC+PW 20 PCS.
S17	31049171AS	SCREW SET,CAP M3*12 NI 50 PCS.
S18	31049170AS	SCREW SET,CAP M3*8 NI 50 PCS.
S19	31049173AS	SCREW SET,CAP M4*10 NI 50 PCS.
S20	31049174AS	SCREW SET,CAP M4*15 NI 20 PCS.
S21	31049137AS	SCREW SET,CAP M4*25 3CBC 20 PCS
S22	31049169AS	SCREW SET,CAP M4*8 3CBC+PW 20PCS
S23	31199701AS	SCREW SET,SET WP M3*3 NI 20 PCS
S24	31229103AS	SCREW SET,TRUSS M2*6 NI 100 PCS
S25	31239103AS	SCREW SET,W-SEMS M3*8 NI+PW 50 PCS
S26	31019703	SCREW,BINDING P-TIGHT M3*8 3C 100P
S27	31049117	SCREW,CAP M4*12 NI+PW 4*9*0.8 20PCS
S28	31069104	SCREW,CAP M4*6+FL NI

1-4 HEAD CARRIAGE (VP-540)

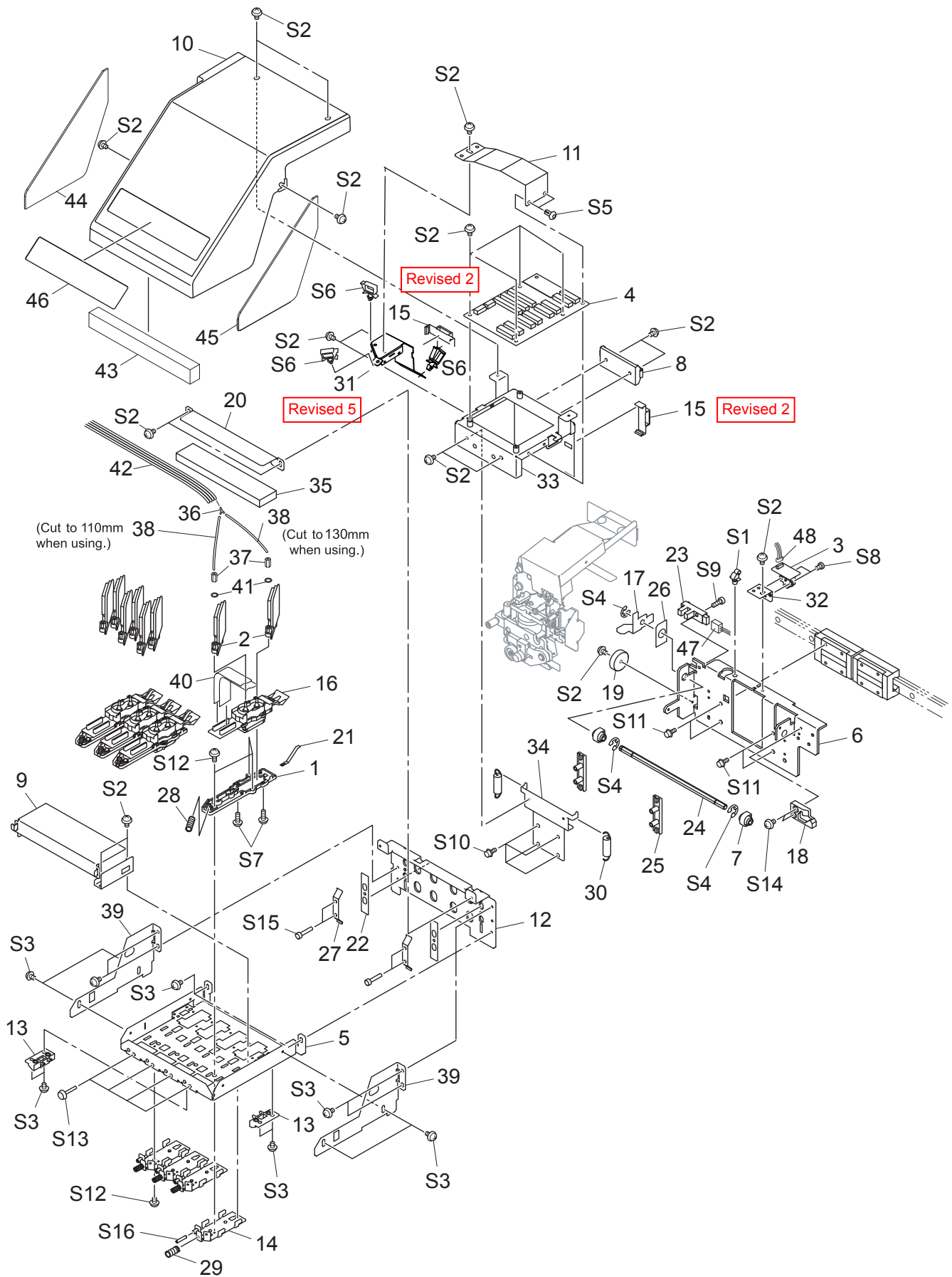

1-4 HEAD CARRIAGE (VP-540)

PARTS LIST -Main Parts-

	Parts No.	Parts Name	
1	21905166	ADAPTER,HEAD FJ-540	
2	6085393800	ASSY,INK DAMPER L 3FAI 4 SJ-1000	
3	W700461130	ASSY,LINEAR ENCODER BOARD VP-540	
4	W700461110	ASSY,PRINT CARRIAGE BOARD VP-540	
5	1000002519	BASE,CARRIAGE AL VP-540	
6	1000002520	BASE,HOLDER CARRIAGE VP-540	
7	21775103	CAM,CARRIAGE FJ-540	
8	11769118	CLAMP,FCM2-S6-14	
9	1000002588	COVER,HEAD BOARD VP-540	
10	1000002632	COVER,PRINT CARRIAGE VP-540	
11	1000002652	COVER,PRINT JUNCTION VP-540	
12	1000002523	FRAME,CARRIAGE U/D VP-540	
13	1000003076	GUIDE,CARRIAGE CAP VP-540	
14	22135440	GUIDE,HEAD AL FJ-540	
15	1000003293	GUIDE,TUBE TYPE3 VP-540	Revised 2
16	1000002201	ASSY,HEAD INKJET SOL XC-540	
17	1000002587	LEVER,CARRIAGE VP-540	
18	21345105	LOCK,CJ-500	
19	22395108	MAGNET,CJ-500	
20	1000002586	PLATE,DAMPER VP-540	
21	22055547	PLATE,GND FJ-540	
22	22055548	PLATE,SLIDER CARRIAGE FJ-540	
23	15229506	SENSOR INTERRUPTER,GP1A05A5	
24	1000002521	SHAFT,HEXAGON CARRIAGE VP-540	
25	22185127	SLIDER,CARRIAGE FJ-540	
26	1000002623	SPACER,U/D LEVER VP-540	
27	22175159	SPRING,CARRIAGE SIDE FJ-50	
28	22175520	SPRING,HEAD ADJUST 500 FJ-540	
29	22175519	SPRING,HEAD PRESS 500 FJ-540	
30	22625109	SPRING,PULL CARRIAGE 3500 FJ-540	
31	1000003863	STAY,CARRIAGE TUBE TYPE2 VP-540	Revised 5
32	1000000417	STAY,ENCORDER SENSOR SP-540V	
33	1000002524	STAY,HOLDER CARRIAGE BOARD VP-540	
34	1000002522	SUPPORT,CARRIAGE BOARD VP-540	
35	1000002643	SUPPORT,DAMPER VP-540	
36	1000002679	ADAPTER,JUNCTION VPY306	
37	11909167	ADAPTER,SCREW 3FAI FJ-540	
38	1000003136	ASSY,TUBING 3*150MM VP-540	
39	1000003032	BASE,CARRIAGE SIDE AL VP-540	
40	23475206	CABLE-CARD 21P1 330L BB	
41	11659249	HOLDER,RING O 3FAI FJ-540	
42	1000002681	TUBE,SJ-RDG3*4 4LINK VP-540	
43	1000003031	SUPPORT,ADJUST SCREW VP-540	
44	1000003075	PAD,PRINT CARRIAGE L VP-540	
45	1000003074	PAD,PRINT CARRIAGE R VP-540	
46	1000002753	LABEL,READ MANUAL VP-540#LA969	
47	1000002171	CABLE-ASSY,HEAD U/D SENSOR VP-540	
48	1000002174	CABLE-ASSY,LINEAR ENCODER VP-540	

PARTS LIST -Supplemental Parts-

	Parts No.	Parts Name
S1	31329601AS	CLAMP SET,INSULOK T-18S 100 PCS.
S2	31289109AS	CUPSCREW SET,M3*4 NI 100 PCS.
S3	31289102AS	CUPSCREW SET,M3*6 NI 50 PCS.
S4	31149703AS	RING SET,E-RING ETW-4 100 PCS.
S5	31299102AS	RIVET SET,NYLON P2655B 20 PCS.
S6	31409801AS	SADDLE,LOCKING WIRE LWS-0711Z 20P
S7	31679902AS	SCREW SET C-SEMS M2*8 NI 100 PCS
S8	31019148AS	SCREW SET,BINDING M2.6*4 NI 100 PCS
S9	31049173AS	SCREW SET,CAP M4*10 NI 50 PCS.
S10	31049169AS	SCREW SET,CAP M4*8 3CBC+PW 20PCS
S11	31049169AS	SCREW SET,CAP M4*8 3CBC+PW 20PCS
S12	31089121AS	SCREW SET,PAN M2.3*8 NI+PW 100PCS
S13	31179908AS	SCREW SET,UREA M3*20 N-1 WH 50PCS
S14	31239125AS	SCREW SET,W-SEMS M3*8 SUS 50 PCS.
S15	31799103	SCREW SET,CAP M3*15 NI 20PCS
S16	31199905AS	SCRW SET,SET CONE M3*16 NI 20 PCS

1-5 HEAD CARRIAGE (VP-300)

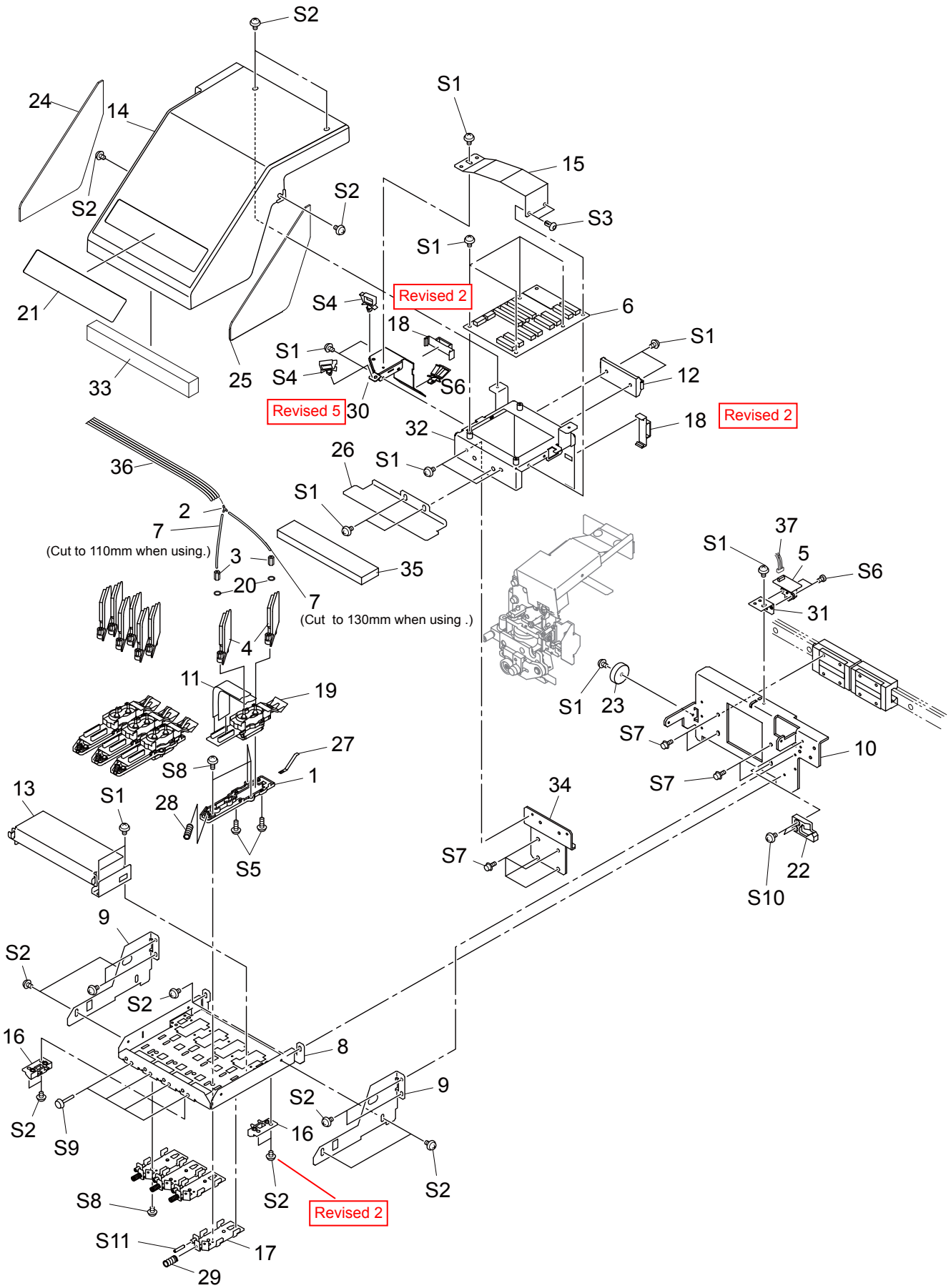

1-5 HEAD CARRIAGE (VP-300)

PARTS LIST -Main Parts-

	Parts No.	Parts Name
1	21905166	ADAPTER,HEAD FJ-540
2	1000002679	ADAPTER,JUNCTION VPY306
3	11909167	ADAPTER,SCREW 3FAI FJ-540
4	6085393800	ASSY,INK DAMPER L 3FAI 4 SJ-1000 Revised 1
5	W700461130	ASSY,LINEAR ENCODER BOARD VP-540
6	W700461110	ASSY,PRINT CARRIAGE BOARD VP-540
7	1000003136	ASSY,TUBING 3*150MM VP-540
8	1000002661	BASE,CARRIAGE AL VP-300
9	1000003032	BASE,CARRIAGE SIDE AL VP-540
10	1000002662	BASE,HOLDER CARRIAGE VP-300
11	23475206	CABLE-CARD 21P1 330L BB
12	11769118	CLAMP,FCM2-S6-14
13	1000002588	COVER,HEAD BOARD VP-540
14	1000002632	COVER,PRINT CARRIAGE VP-540
15	1000002652	COVER,PRINT JUNCTION VP-540
16	1000003076	GUIDE,CARRIAGE CAP VP-540 Revised 2
17	22135440	GUIDE,HEAD AL FJ-540
18	1000003293	GUIDE,TUBE TYPE3 VP-540 Revised 2
19	1000002201	ASSY,HEAD INKJET SOL XC-540
20	11659249	HOLDER,RING O 3FAI FJ-540
21	1000002753	LABEL,READ MANUAL VP-540#LA969
22	21345105	LOCK,CJ-500
23	22395108	MAGNET,CJ-500
24	1000003075	PAD,PRINT CARRIAGE L VP-540
25	1000003074	PAD,PRINT CARRIAGE R VP-540
26	1000002664	PLATE,DAMPER VP-300
27	22055547	PLATE,GND FJ-540
28	22175520	SPRING,HEAD ADJUST 500 FJ-540
29	22175519	SPRING,HEAD PRESS 500 FJ-540
30	1000003863	STAY,CARRIAGE TUBE TYPE2 VP-540 Revised 5
31	1000000417	STAY,ENCORDER SENSOR SP-540V
32	1000002524	STAY,HOLDER CARRIAGE BOARD VP-540
33	1000003031	SUPPORT,ADJUST SCREW VP-540
34	1000002663	SUPPORT,CARRIAGE BOARD VP-300
35	1000002643	SUPPORT,DAMPER VP-540
36	1000002670	TUBE,SJ-RDG3*4 4LINK VP-300
37	1000002174	CABLE-ASSY,LINEAR ENCODER VP-540

PARTS LIST -Supplemental Parts-

	Parts No.	Parts Name
S1	31289109AS	CUPSCREW SET,M3*4 NI 100 PCS.
S2	31289102AS	CUPSCREW SET,M3*6 NI 50 PCS.
S3	31299102AS	RIVET SET,NYLON P2655B 20 PCS.
S4	31409801AS	SADDLE,LOCKING WIRE LWS-0711Z 20P
S5	31679902AS	SCREW SET C-SEMS M2*8 NI 100 PCS
S6	31019148AS	SCREW SET,BINDING M2.6*4 NI 100 PCS
S7	31049169AS	SCREW SET,CAP M4*8 3CBC+PW 20PCS
S8	31089121AS	SCREW SET,PAN M2.3*8 NI+PW 100PCS
S9	31179908AS	SCREW SET,UREA M3*20 N-1 WH 50PCS
S10	31239125AS	SCREW SET,W-SEMS M3*8 SUS 50 PCS.
S11	31199905AS	SCRW SET,SET CONE M3*16 NI 20 PCS

1-6 BASE FRAME

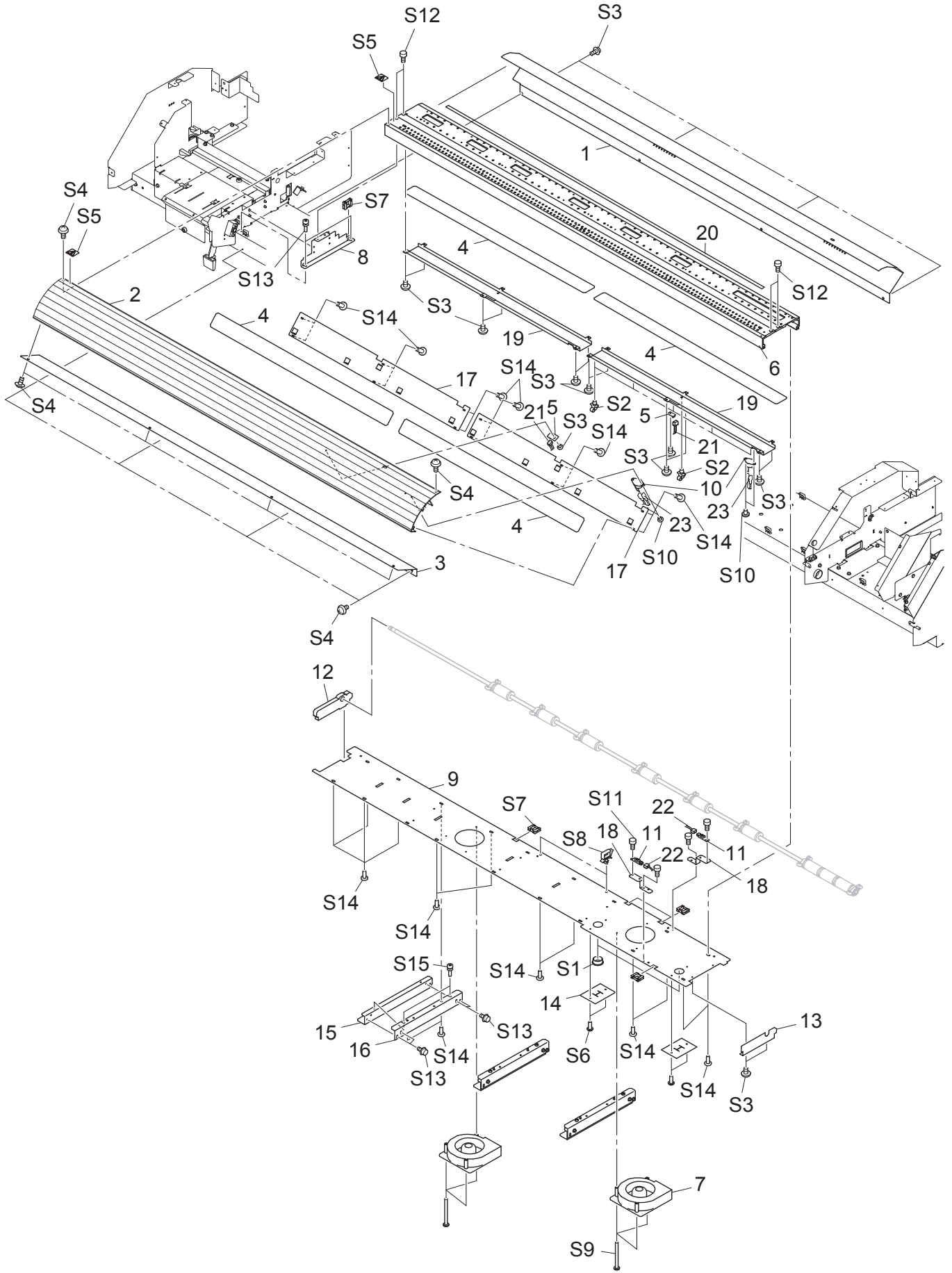

1-6 BASE FRAME

PARTS LIST -Main Parts-

	Parts No.	Parts Name
1	1000002654	APRON,B VP-300
	1000002553	APRON,B VP-540
2	1000002152	APRON,F AL VP-300
	1000002148	APRON,F AL VP-540
3	1000002655	APRON,F UNDER VP-300
	1000002542	APRON,F UNDER VP-540
4	1000002166	ASSY,CORD HEATER VP-300
	1000002165	ASSY,CORD HEATER VP-540
5	W700461270	ASSY,THERMISTOR BOARD VP-540
6	1000002151	BED,VP-300
	1000002147	BED,VP-540
7	1000000764	FAN,A35577-55ROL
8	1000002584	FRAME,SIDE BED L VP-540
9	1000002657	PLATE,SHUTTER VP-300
	1000002541	PLATE,SHUTTER VP-540
10	15099124	SENSOR,US-602SXTLAS 65OFF 50ON
11	15099115	SENSOR-INTERRUPTER GP2A25NJ
12	1000002600	SHUTTER,BED L VP-540
13	1000002599	SHUTTER,BED R VP-540
14	21625103	SHUTTER,HEATER CORD SP-300
15	1000002582	SPACER,BED LOWER VP-540
16	1000002583	SPACER,BED UPPER VP-540
17	1000002669	STAY,DRY HEATER VP-300
	1000002606	STAY,DRY HEATER VP-540
18	1000002585	STAY,PAPER SENSOR VP-540
19	1000002668	STAY,PRINT HEATER VP-300
	1000002590	STAY,PRINT HEATER VP-540
20	1000002656	PAD,CUTTER VP-300
	1000002598	PAD,CUTTER VP-540
21	1000002181	CABLE-ASSY,THERMISTOR VP-540
22	1000002175	CABLE-ASSY,PAPER SENSOR VP-540
23	1000002184	CABLE-ASSY,THERMOSTAT VP-540

PARTS LIST -Supplemental Parts-

	Parts No.	Parts Name
S1	31029101	BUSH,NB-19
S2	31329501AS	CLAMP SET,PUSH MOUNT RT30SSF5 20P
S3	31289109AS	CUPSCREW SET,M3*4 NI 100 PCS.
S4	31289102AS	CUPSCREW SET,M3*6 NI 50 PCS.
S5	31279106	LABEL,CAUTION HOT SURF NO.778
S6	31299102AS	RIVET SET,NYLON P2655B 20 PCS.
S7	31409702	SADDLE SET,LOCKING WIRE LES-1010 20P
S8	31409801AS	SADDLE,LOCKING WIRE LWS-0711Z 20P
S9	31019124	SCREW SET,BINDING M3*35 NI 50 PCS
S10	31019115AS	SCREW SET,BINDING M3*4 3CBC 100 PCS
S11	31049170AS	SCREW SET,CAP M3*8 NI 50 PCS.
S12	31049173AS	SCREW SET,CAP M4*10 NI 50 PCS.
S13	31049169AS	SCREW SET,CAP M4*8 3CBC+PW 20PCS
S14	31019703	SCREW,BINDING P-TIGHT M3*8 3C 100P
S15	31179106	SCREW,JACK UP SP-540V

1-7 CHASSIS

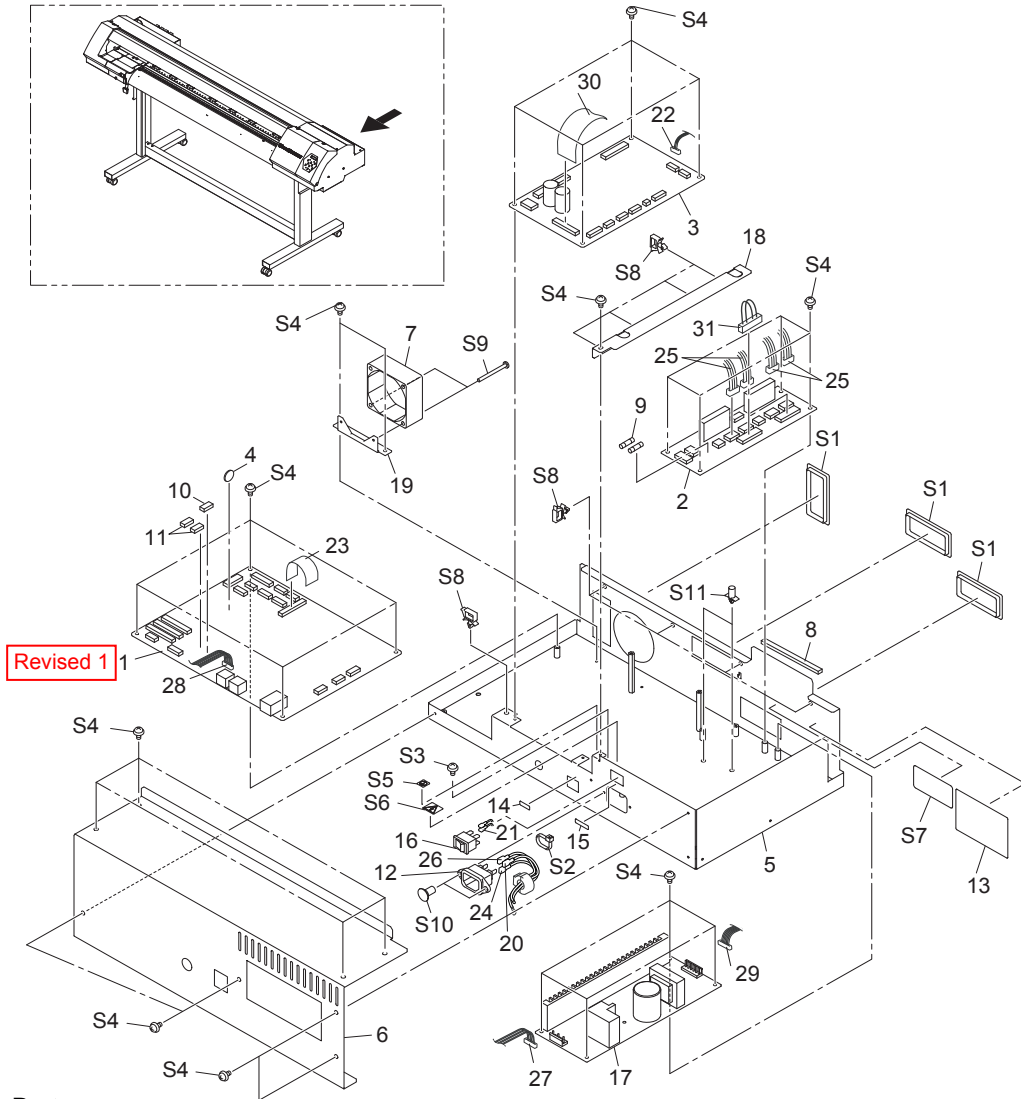

PARTS LIST -Main Parts-

Parts No.	Parts Name
1	6700469010 ASSY,MAIN BOARD VP-540 Revised 1
2	W700461220 ASSY,POWER BOARD VP-540
3	1000002144 ASSY,SERVO BOARD VP-540
4	15009101 BATTERY CR2032
5	1000002559 CHASSIS,VP-540
6	1000002633 COVER,CHASSIS VP-540
7	1000000012 FAN,109R0624H459
8	1000003085 FILTER(E),CHASSIS SHIELD VP-540
9	12559105 FUSE
10	1000003014 FUSE,154002.DR
11	1000003015 FUSE,1543.15DR
12	13429702 INLET AC P01CF01 15A250V
13	22535257 LABEL,CAUTION VOLTAGE #LA167
14	1000002682 LABEL,LAN VP-540#LA964
15	22535117 LABEL,POWER CM-500 NO.893
16	13129170 POWER SW AJ7201B
17	12429114 POWER UNIT,ZWS150PAF-36J
18	1000002579 STAY,CABLE VP-540
19	1000002566 STAY,CHASSIS FAN VP-540
20	1000002189 CABLE-ASSY,JUNBI A VP-540
21	23415116 CABLE ASSY,JUNBI D SP-300
22	23415117 CABLE ASSY,POWER MAIN SP-300
23	23475197 CABLE CARD 25P1 105L BB FJ-540
24	23415268 CABLE-ASSY AC GROUND GREEN SP-540

Parts No.	Parts Name
25	1000002755 CABLE-ASSY,HEATER VP-300
	1000002183 CABLE-ASSY,HEATER VP-540
26	1000002190 CABLE-ASSY,JUNBI B VP-540
27	1000002173 CABLE-ASSY,JUNBI E VP-540
28	1000002177 CABLE-ASSY,POWER SERVO VP-540
29	1000002180 CABLE-ASSY,RELAY JUNCTION VP-540
30	23475216 CABLE-CARD,40P1 1400L BB (For VP-300)
	23475237 CABLE-CARD,40P1 2070L BB HIGH-V (For VP-540)
31	1000002044 CABLE-ASSY,117V SELECTOR XC-540 (For 117V)
	1000002043 CABLE-ASSY,230V SELECTOR XC-540 (For 230V)

PARTS LIST -Supplemental Parts-

Parts No.	Parts Name
S1	31029106 BUSH,SQUARE SB-6025
S2	31329601AS CLAMP SET,INSULOK T-18S 100 PCS.
S3	31289111AS CUPSCREW SET, M4*6 NI 100 PCS.
S4	31289109AS CUPSCREW SET,M3*4 NI 100 PCS.
S5	31279116 LABEL,EARTH MARK-1 NO.E-580
S6	31279121 LABEL,FLASH-LIGHTING NO.E-582
S7	31279191 LABEL,WARNING FUSE REPLACE #347
S8	31409801AS SADDLE,LOCKING WIRE LWS-0711Z 20P
S9	31019124 SCREW SET,BINDING M3*35 NI 50 PCS
S10	31169103AS SCREW SET,FLAT M3*6 3CBC 100 PCS
S11	31369102 SPACER,PCB SUPPORT PCB-8S

1-8 PINCH ROLLER

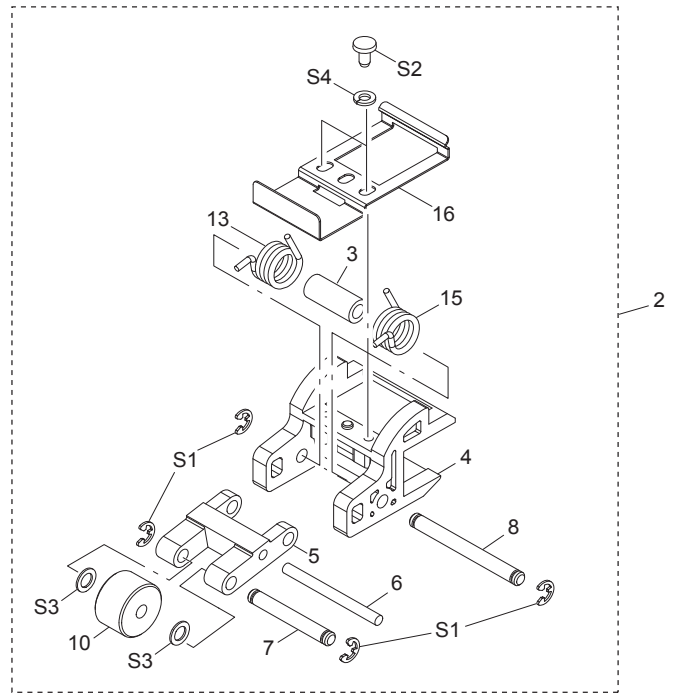
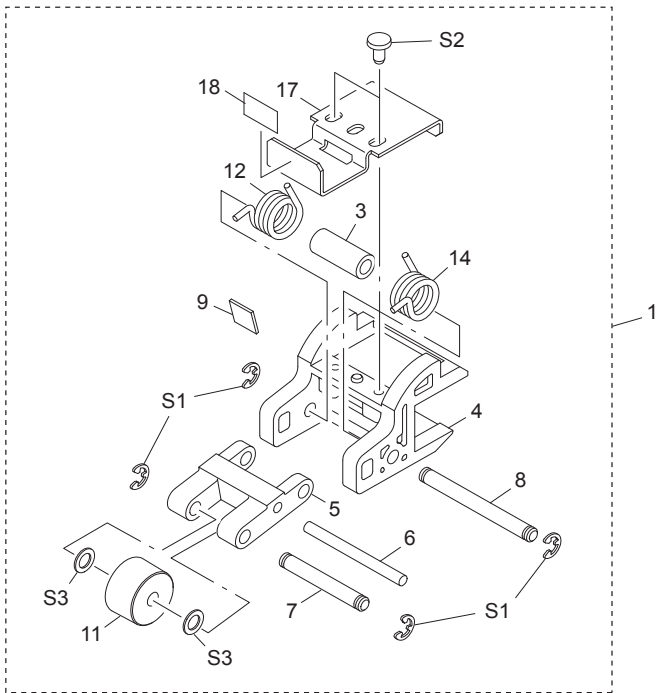

PARTS LIST -Main Parts-

	Parts No.	Parts Name
1	6700460210	ASSY,PINCHROLL L VP-540
	6700460220	ASSY,PINCHROLL R VP-540
2	6700460300	ASSY,PINCHROLL C VP-540
3	21745101	COLLAR,P-ROLLER PNC-960
4	22195153	FRAME,PINCH ROLL SP-540V
5	22145416	LEVER,P-ROLLER PNC-960
6	11539104	PIN 3*35 SUS M6
7	22145831	PIN NO.1 (214-831)
8	22145832	PIN NO.2 214-832
9	22055264	PLATE,GUIDE P PNC-960
10	21565103	P-ROLLER FD16S4(B10) TYPE2
11	21565102	P-ROLLER TD16S4(B10) TYPE2
12	22625101	SPRING,PINCH LEFT SP-300
13	1000002648	SPRING,PINCH LEFT VP-540
14	22625102	SPRING,PINCH RIGHT SP-300
15	1000002649	SPRING,PINCH RIGHT VP-540
16	22715461	STAY,PINCH CENTER SP-540V
17	1000003028	STAY,PINCH SENSOR VP-540
18	1000002973	LABEL,PINCH SENSOR VP-540 #LA979

PARTS LIST -Supplemental Parts-

	Parts No.	Parts Name
S1	31149702AS	RING SET,E-RING ETW-3 100 PCS.
S2	31019702AS	SCREW SET,BIND P-TIGHT M3*6 3C 100P
S3	31249211AS	WASHER SET,PLAIN 4.3*7*0.5 NI 100P
S4	31249303	WASHER SET,SPRING M3 NI 100 PCS

1-9 STAND

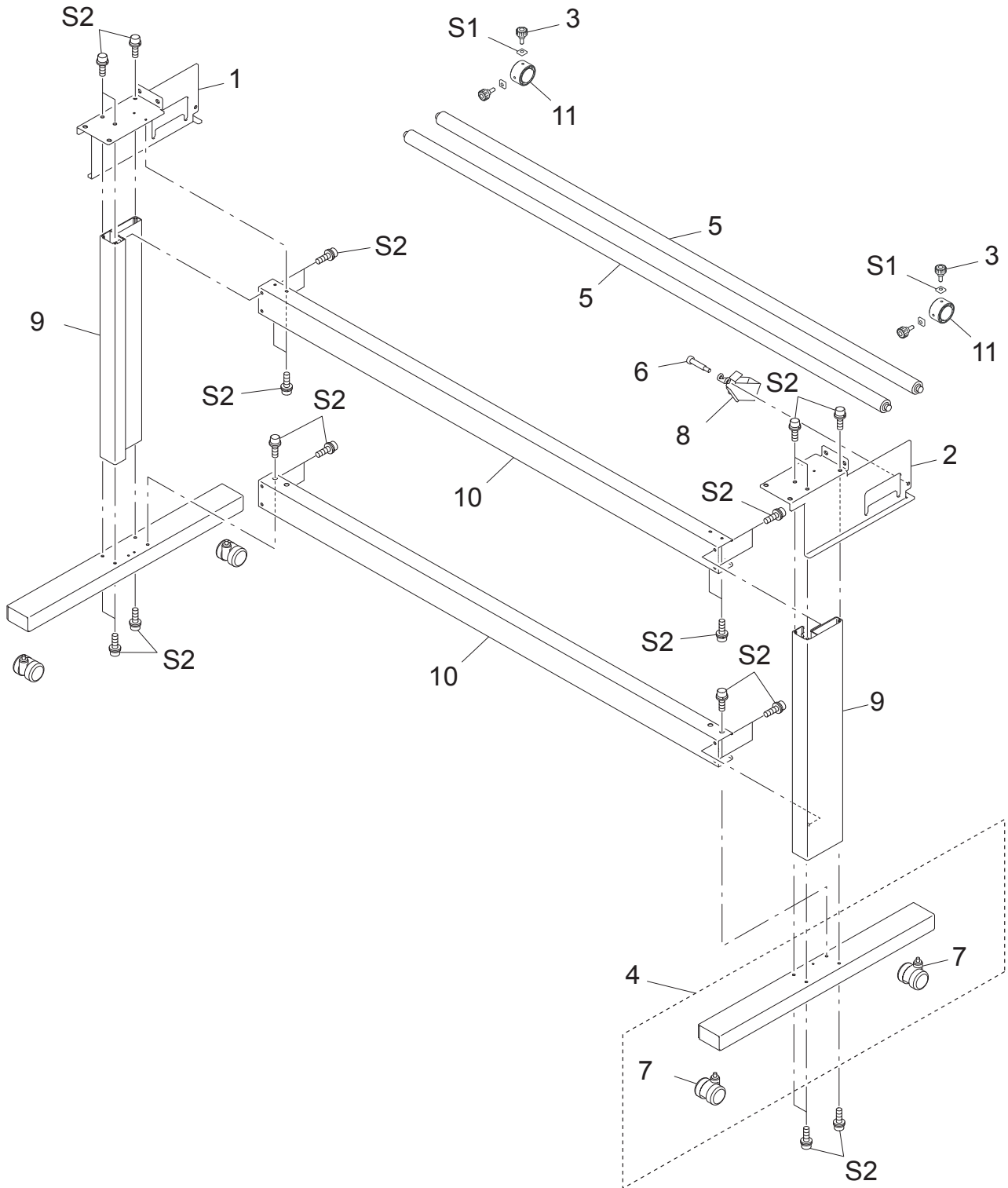

PARTS LIST -Main Parts-

	Parts No.	Parts Name
1	1000002578	ARM,L VP-540
2	1000002577	ARM,R VP-540
3	7498805000	ASSY STOPPER SCREW PNS-501
4	1000002636	ASSY,BASE STAND VP-540
5	1000002153	ASSY,SHAFT SHEET VP-300
	1000001611	ASSY,SHAFT SHEET XC-540
6	21815106	BOLT,SHOULDER PNS-501
7	12329505	CASTER,BWS-50BN
8	1000002618	LEVER,BRAKE VP-540

	Parts No.	Parts Name
9	1000002149	STAND,LEG VP-540
10	1000002678	STAY,STAND VP-300
	1000002635	STAY,STAND VP-540
11	1000001579	STOPPER,SHAFT POM XC-540

PARTS LIST -Supplemental Parts-

	Parts No.	Parts Name
S1	3000000036	NUT SET,SQUARE M5 8.5*8.5*2.3 3C 100PCS
S2	31049157	SCREW,CAP M6*20 3CBC+PW+SW

1-10 TOOL CARRIAGE

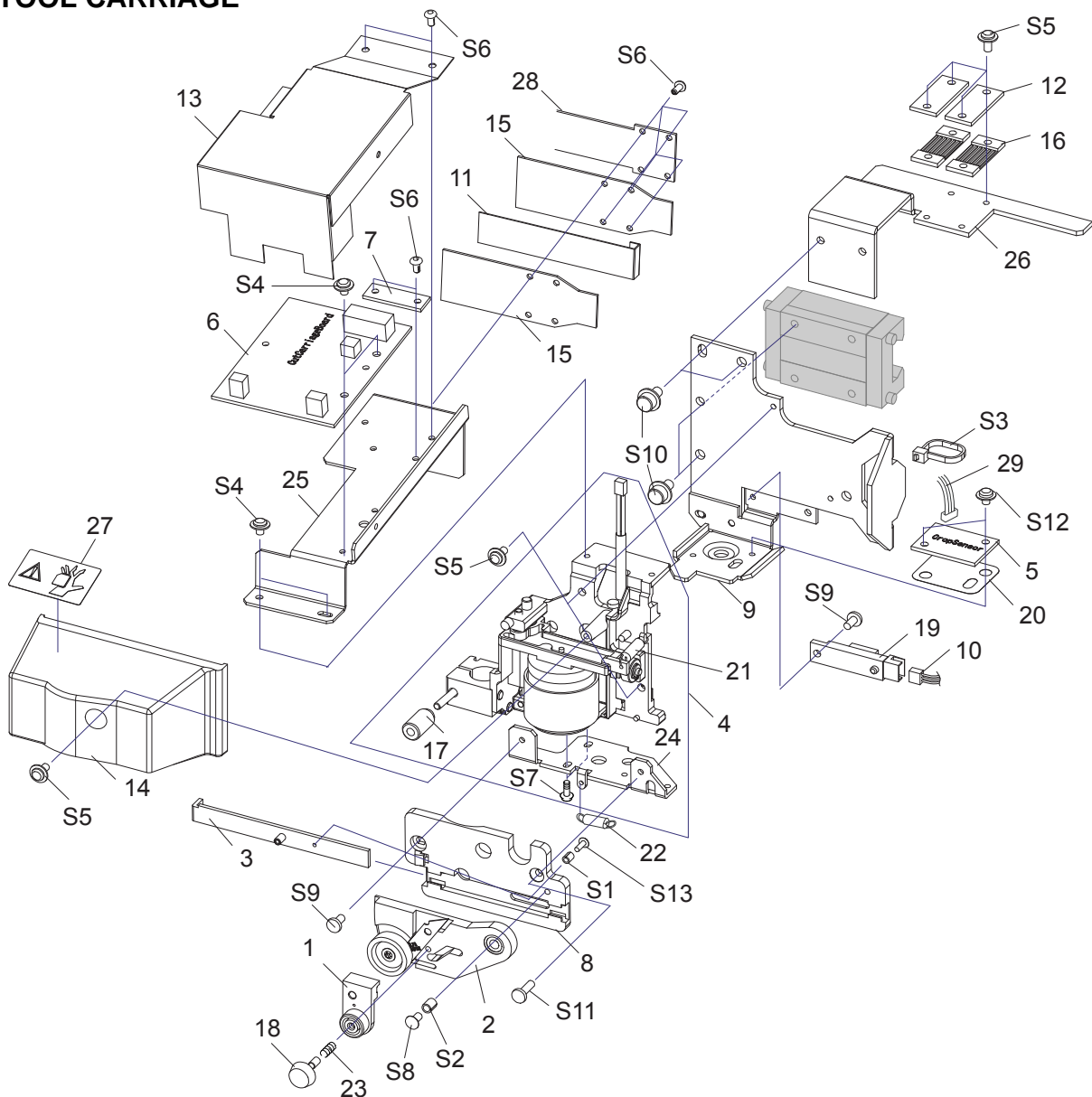

PARTS LIST -Main Parts-

Parts No.	Parts Name
1	22805292 ASSY, CLAMP BLADE CM-500
2	22805291 ASSY, HOLDER BLADE CM-500
3	22805287 ASSY, PLATE CAM SLIDE CM-500
4	22805571 ASSY,CARRIAGE SP-300
5	W700461250 ASSY,CROP SENSOR BOARD VP-540
6	W700461120 ASSY,CUT CARRIAGE BOARD VP-540
7	W700461290 ASSY,FLEX1 VP-540
8	7488739000 BASE CUTTER CJ-500
9	1000002530 BASE,CUT CARRIAGE VP-540
10	1000002185 CABLE-ASSY,PINCH SENSOR VP-540
11	23475207 CABLE-CARD,15P1 1900L BB (For VP-300)
	23475238 CABLE-CARD,15P1 2570L BB HIGH-V (For VP-540)
12	22025646 COVER,BELT HOLDER EGX-600
13	1000002570 COVER,CARRIAGE BOARD VP-540
14	22025269 COVER,CARRIAGE CM-500
15	1000002667 GUIDE,CABLE FLEX-CUT VP-300
	1000002591 GUIDE,CABLE FLEX-CUT VP-540
16	21655232 HOLDER,BELT EGX-600
17	22285503 NUT,PENHOLDER
18	21495115 SCREW,BLADE SET CM-500
19	15099115 SENSOR-INTERRUPTER GP2A25NJ
20	21475148 SHEET,FILTER CROP CJ-500
21	22175122 SPRING,BACKUP PNC-960
22	22175154 SPRING,BLADE UP CM-500

Parts No.	Parts Name
23	22175155 SPRING,SCREW CM-500
24	22715168 STAY,AUTO CUTTER 2 CM-500
25	1000002531 STAY,CUT CARRIAGE BOARD VP-540
26	1000002540 STAY,HOLDER BELT VP-540
27	22535287 LABEL,CAUTION CARRIAGE #LA266
28	1000002674 PLATE,CABLE CUT VP-300
	1000002613 PLATE,CABLE CUT VP-540
29	1000002187 CABLE-ASSY,CROP SENSOR VP-540

PARTS LIST -Supplemental Parts-

Parts No.	Parts Name
S1	31029801AS BUSH SET,ROLL 2*4 3C100PCS
S2	31029803AS BUSH SET,ROLL 3*5 3C 20PCS.
S3	31329601AS CLAMP SET,INSULOK T-18S 100 PCS.
S4	31289109AS CUPSCREW SET,M3*4 NI 100 PCS.
S5	31289102AS CUPSCREW SET,M3*6 NI 50 PCS.
S6	31299102AS RIVET SET,NYLON P2655B 20 PCS.
S7	31019148AS SCREW SET,BINDING M2.6*4 NI 100 PCS Revised 6
S8	31019118AS SCREW SET,BINDING M3*10 3CBC 100PCS
S9	31019116AS SCREW SET,BINDING M3*6 3CBC 100 PCS
S10	31069104 SCREW,CAP M4*6+FL NI
S11	31169103AS SCREW SET,FLAT M3*6 3CBC 100 PCS
S12	31089110AS SCREW SET,PAN M3*4 NI+PW 100 PCS
S13	31229103AS SCREW SET,TRUSS M2*6 NI 100 PCS

1-11 WIPER SYSTEM

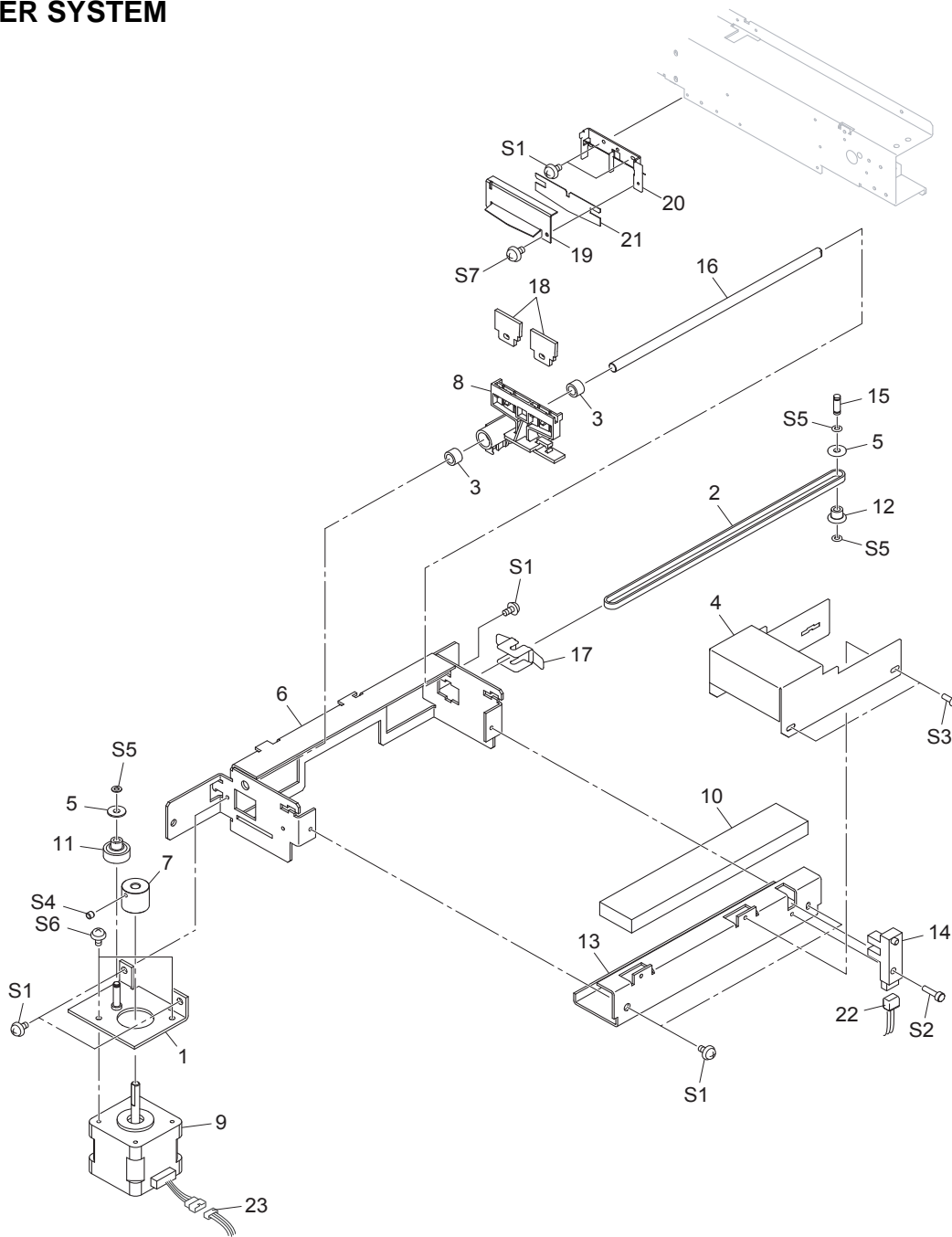

PARTS LIST -Main Parts-

Parts No.	Parts Name
1	1000002576 BASE,WIPER MOTOR VP-540
2	11929138 BELT,408P2M4-530
3	12159536 BUSH,B-S6-17
4	1000002572 COVER,WIPE VP-540
5	21995104 FLANGE,PULLEY STX-7
6	1000002574 FRAME,WIPER VP-540
7	21685144 GEAR,S53S5(B15) FJ-540
8	21655245 HOLDER,WIPER FJ-540
9	22435106 MOTOR,103-593-1041
10	21545160 PAD,WIPER TRAY SJ-540
11	21975124 PULLEY,T14P2S4 + GEAR,S53
12	21975123 PULLEY,WD6.94S9
13	1000002575 RAIL,GUIDE WIPER VP-540
14	15229506 SENSOR INTERRUPTER,GP1A05A5
15	22295132 SHAFT,IDLE PULLEY STX-7
16	22155961 SHAFT,WIPER FJ-540
17	22175140 SPRING,TENSIONER STX-7

Parts No.	Parts Name
18	11379105 WIPER,HEAD ASP FJ-50
19	1000002573 COVER,SCRAPER VP-540
20	1000002571 HOLDER,SCRAPER VP-540
21	1000001658 WIPER,SCRAPER XC-540
22	1000002186 CABLE-ASSY,WIPER SENSOR VP-540
23	1000002182 CABLE-ASSY,WIPER MOTOR VP-540

PARTS LIST -Supplemental Parts-

Parts No.	Parts Name
S1	31289109AS CUPSCREW SET,M3*4 NI 100 PCS.
S2	31049171AS SCREW SET,CAP M3*12 NI 50 PCS.
S3	31049170AS SCREW SET,CAP M3*8 NI 50 PCS.
S4	31199701AS SCREW SET,SET WP M3*3 NI 20 PCS
S5	31249952 WASHER SET,POLYSLIDER 2.6*5*.5 CUT 20PCS
S6	31289102AS CUPSCREW SET,M3*6 NI 50 PCS.
S6	31289102AS CUPSCREW SET,M3*6 NI 50 PCS.
S7	31289112AS CUPSCREW SET,M3*10 NI 100 PCS.

1-12 PUMP SYSTEM

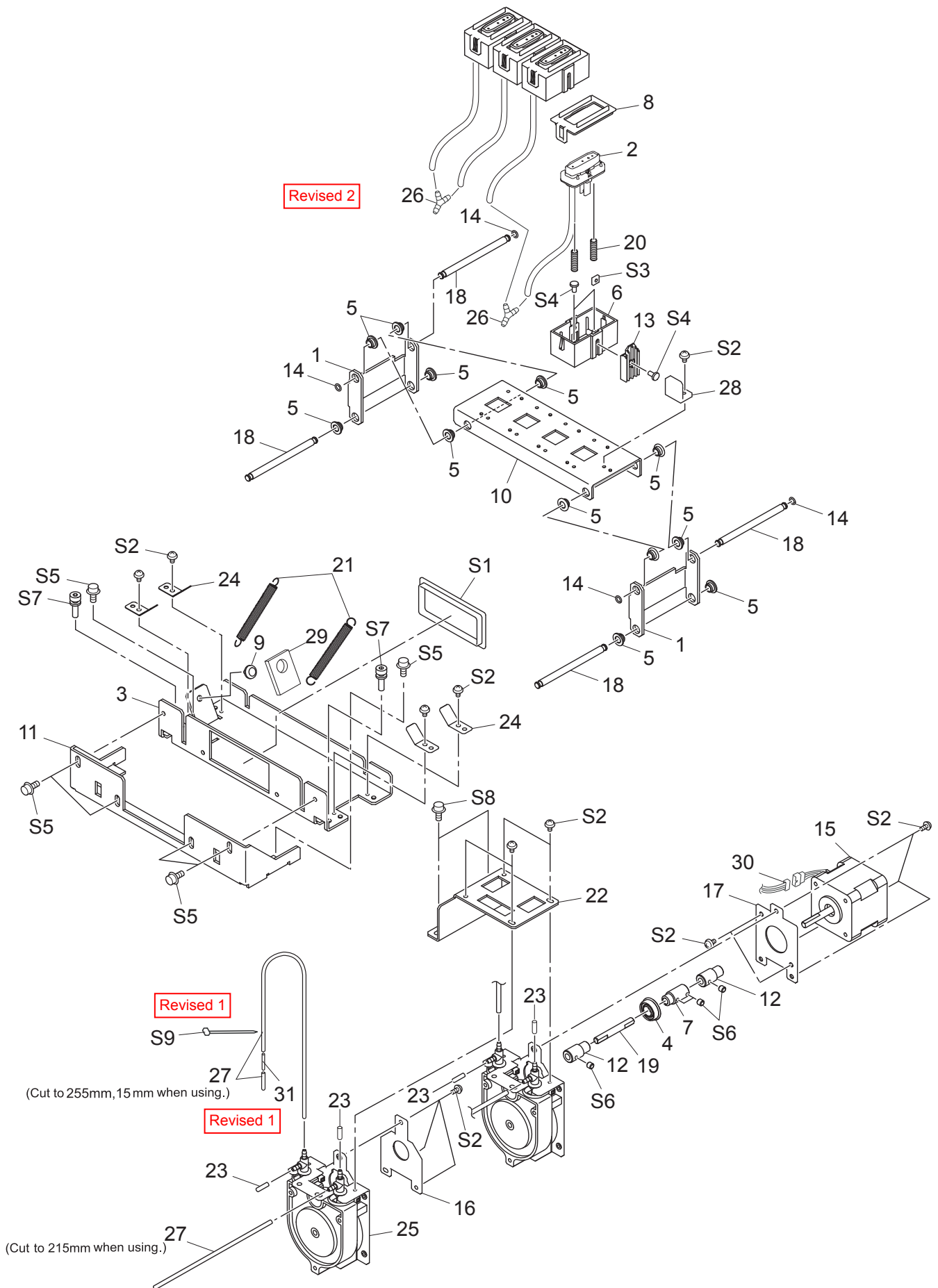

1-12 PUMP SYSTEM

PARTS LIST -Main Parts-

	Parts No.	Parts Name	
1	1000002537	ARM, LINK UP VP-540	
2	1000002794	ASSY, CAP-TOP XC-540	
3	1000002538	BASE, CAP VP-540	
4	22175815	BEARING F8-16ZZ	
5	1000000796	BUSH, 80F-0503	
6	21365121	CASE, CAP TOP FJ-540	
7	1000002564	COUPLING, PUMP VP-540	
8	22025671	COVER, CAP CASE FJ-540	
9	12239406	CUSHION, TM-96-6	
10	1000002536	FRAME, BACK-UP CAP VP-540	
11	1000002580	FRAME, BASE CAP VP-540	
12	21685122	GEAR, S10S20	
13	22135616	GUIDE, CAP CASE FJ-540	
14	11659249	HOLDER, RING O 3FAI FJ-540	
15	22435106	MOTOR, 103-593-1041	
16	1000002595	PLATE, P-BEARING VP-540	
17	1000001585	PLATE, P-MOTOR XC-540	
18	1000002539	SHAFT, CAP VP-540	
19	1000002563	SHAFT, PUMP VP-540	
20	22175334	SPRING, CAP HEAD FJ-540	
21	1000002561	SPRING, CAP SWING VP-540	
22	1000002565	STAY, PUMP ASSY VP-540	
23	1000002019	STOPPER, PUMP XC-540	
24	1000002645	STOPPER, SHAFT CAP VP-540	
25	6700319010	ASSY, PUMP SUB XC-540	
26	1000002095	FITTING, TUBE PP VFY206	Revised 2
27	1000002119	TUBE, EPDM ID2-OD4 310MM	
28	1000003033	STAY, GUIDE CAP-CASE VP-540	
29	1000003104	SHEET, BASE CAP VP-540	
30	1000002179	CABLE-ASSY, PUMP MOTOR VP-540	
31	1000003383	ASSY, TUBING 2*30MM VP-540	Revised 1

PARTS LIST -Supplemental Parts-

	Parts No.	Parts Name	
S1	31029106	BUSH, SQUARE SB-6025	
S2	31289109AS	CUPSCREW SET, M3*4 NI 100 PCS.	
S3	31109601AS	NUT SET, SQUARE M3*6*1.6 FE NI 100PCS	
S4	31019116AS	SCREW SET, BINDING M3*6 3CBC 100 PCS	
S5	31049169AS	SCREW SET, CAP M4*8 3CBC+PW 20PCS	
S6	31199701AS	SCREW SET, SET WP M3*3 NI 20 PCS	
S7	31179106	SCREW, JACK UP SP-540V	
S8	31289111AS	CUPSCREW SET, M4*6 NI 100 PCS.	
S9	31329601AS	CLAMP SET, INSULOK T-18S 100 PCS.	Revised 1

1-13 INK SYSTEM

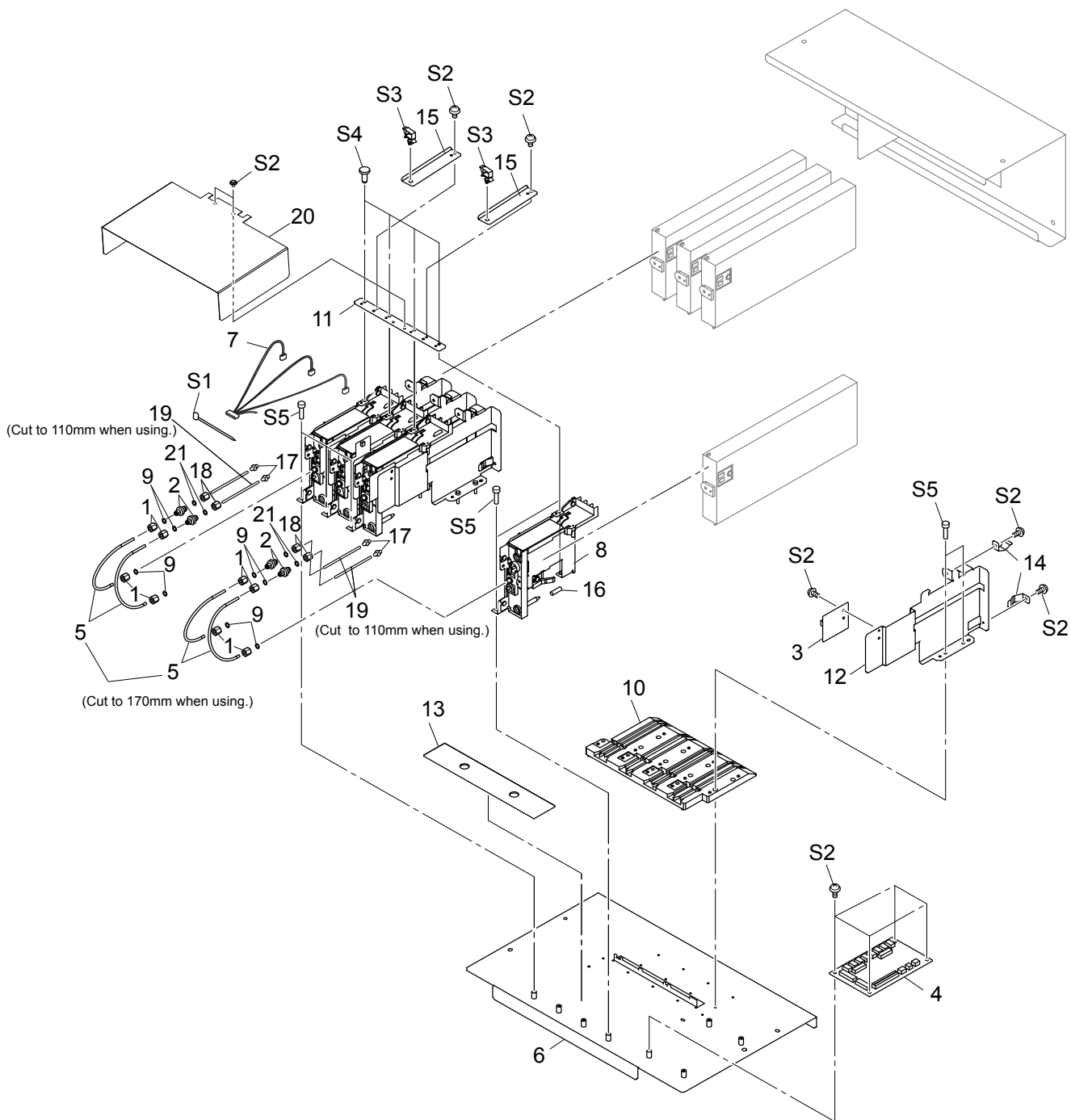

PARTS LIST -Main Parts-

Parts No.	Parts Name
1	11909133 ADAPTER,SCREW 2FAI FJ-50
2	1000001589 ADAPTER,TUBE 2-3FAI XC-540
3	W700461280 ASSY,CARTRIDGE IC BOARD VP-540
4	W700461230 ASSY,FEED MOTOR BOARD VP-540
5	1000002423 ASSY,TUBING 2*210MM XC-540
6	1000002568 BASE,INKCARTRIDGE VP-540
7	1000002172 CABLE-ASSY,INK CARTRIDGE VP-540
8	11659218 HOLDER,I/C SC-500
9	11659149 HOLDER,RING O 2FAI FJ-50
10	22055435 PLATE,INK FJ-500
11	1000002560 PLATE,INK JOINT VP-540
12	1000001473 PLATE,HOLDER I/C XC-540
13	21475153 SHEET,INKCARTRIDGE SP-300
14	22625103 SPRING,PRESS CARTRIDGE SP-300
15	1000002640 SUPPORT,TUBE VP-540

Parts No.	Parts Name
16	21435109 TUBE,SILICONE 3*5*8
17	1000002680 ADAPTER,JOINT VPI336
18	11909167 ADAPTER,SCREW 3FAI FJ-540
19	1000003136 ASSY,TUBING 3*150MM VP-540
20	1000003038 COVER,CARTRIDGE IC VP-540
21	11659249 HOLDER,RING O 3FAI FJ-540

PARTS LIST -Supplemental Parts-

Parts No.	Parts Name
S1	31329601AS CLAMP SET,INSULOK T-18S 100 PCS.
S2	31289109AS CUPSCREW SET,M3*4 NI 100 PCS.
S3	31409801AS SADDLE,LOCKING WIRE LWS-0711Z 20P
S4	31019801 SCREW,BINDING S-TIGHT M3*6 3C 100PCS
S5	31799103 SCREW SET,CAP M3*15 NI 20PCS

1-14 ACCESSORY (VP-540:Below ZW65382, VP-300:Below ZW61509)

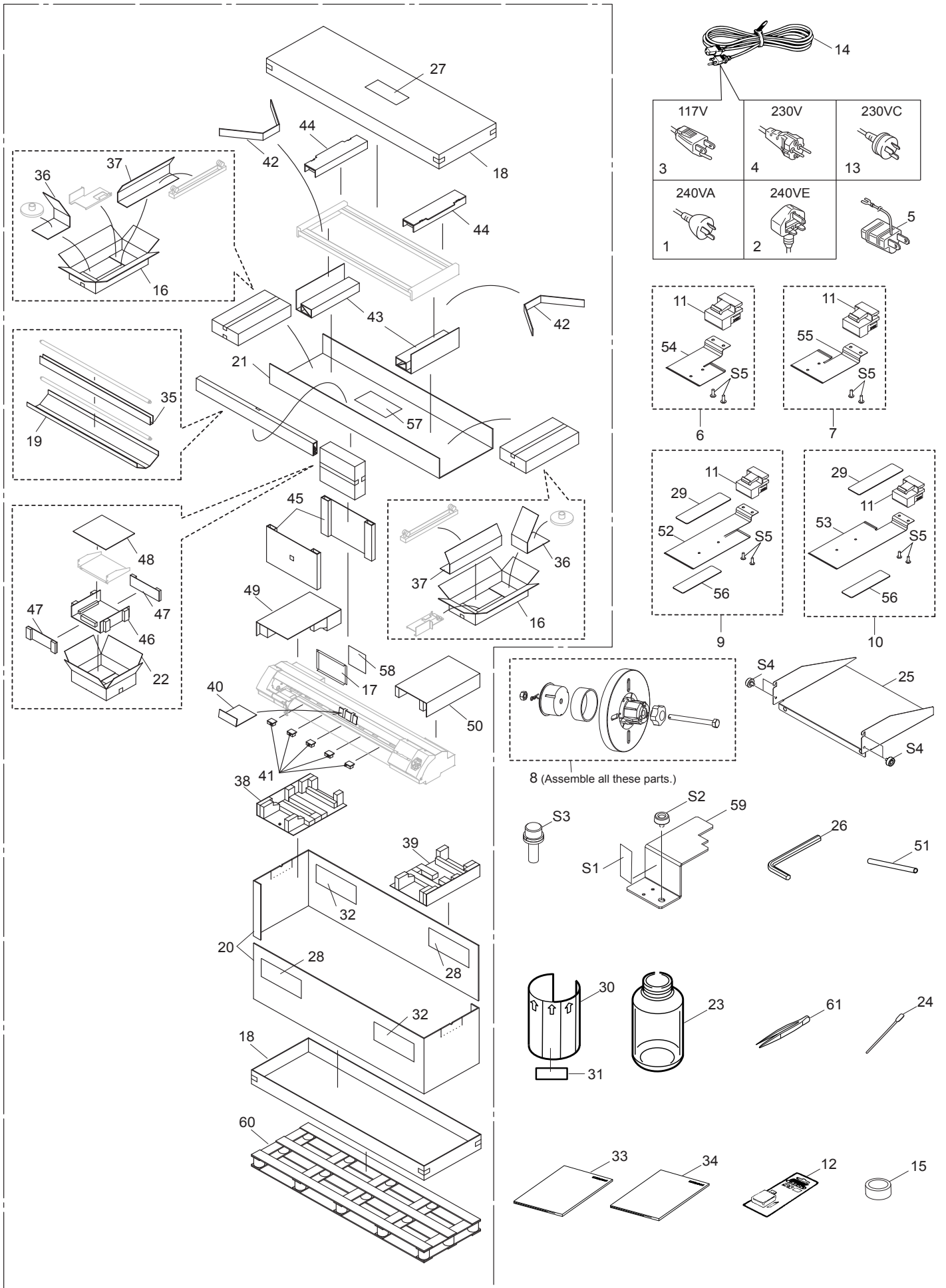

1-14 ACCESSORY (VP-540:Below ZW65382, VP-300:Below ZW61509)

PARTS LIST -Main Parts-

	Parts No.	Parts Name
1	23495124	AC CORD 3ASL100 240VA 10A SAA
2	13499111	AC CORD H05VV-F 240VE 10A S
3	13499109	AC CORD SJT 117V 10A 3PVC
4	23495125	AC-CORD H05VV 230V 10A S
5	13499209	ADAPTER PLUG (100V)
6	22805575	ASS'Y, SHORT MEDIA CLAMP L SP-540V
7	22805576	ASS'Y, SHORT MEDIA CLAMP R SP-540V
8	1000003083	ASSY,FLANGE GUIDE VP-540
9	6700469040	ASSY,MEDIA CLAMP L LONG VP-540
10	6700469050	ASSY,MEDIA CLAMP R LONG VP-540
11	22845112	BASE,MEDIA CLAMP SP-300
12	11849102	BLADE,OLFA AUTO CUTTER XB10
13	13439801	CABLE-AC 3P CHINA 10A250V S
14	23495117	CABLE-AC,VCTF 100V 12A 3P-S
15	22335143	CAP,EPDM
16	1000002698	CARTON,ACCESSORY VP-540
17	22605305	CARTON,COVER INK SP-300
18	1000002701	CARTON,COVER VP-300
	1000002688	CARTON,COVER VP-540
19	1000002704	CARTON,SHAFT SHEET VP-300
	1000002699	CARTON,SHAFT SHEET VP-540
20	1000002702	CARTON,SLEEVE VP-300
	1000002689	CARTON,SLEEVE VP-540
21	1000002703	CARTON,STAND VP-300
	1000002694	CARTON,STAND VP-540
22	1000003077	CARTON,TRAY 440 VP-540
23	11369115	CASE,PP BOTTLE
24	ST-037	CLEAN STICK TX712A
25	1000002650	COVER,440CC I/C VP-540
26	22565682	HEXAGONAL WRENCH 5
27	22535532	LABEL,CARTON CARE #LA762
28	1000002683	LABEL,CARTON VP-300#LA965
	1000002684	LABEL,CARTON VP-540#LA966
29	22535469	LABEL,CAUTION CLAMP SP-300#LA677
30	22535144	LABEL,DRAIN BOTTLE #LA29
31	1000001099	LABEL,HARMFUL FIRE #LA915
32	22535357	LABEL,USE FORKLIFT #LA435
33	1000002751	MANUAL,INS EN VP-540 MAX
	1000002749	MANUAL,INS JP VP-540 MAX
34	1000002750	MANUAL,USE EN VP-540 COMMON
	1000002748	MANUAL,USE JP VP-540 COMMON
35	1000003030	PAD, SHAFT SHEET VP-540
	1000003112	PAD,SHAFT SHEET VP-300
36	1000002968	PAD,ACCESSORY VP-540

PARTS LIST -Main Parts-

	Parts No.	Parts Name
37	1000003111	PAD,BASE STAND VP-540
38	1000002690	PAD,L-LEFT VP-540
39	1000002691	PAD,L-RIGHT VP-540
40	1000003110	PAD,RAIL UPPER VP-540
41	21545178	PAD,SPACER RAIL SP-300
42	1000002697	PAD,SPACER STAND VP-540
43	1000002695	PAD,STAND L/R VP-540
44	1000002696	PAD,STAND UPPER VP-540
45	1000002969	PAD,SUPPORT STAND VP-540
46	1000003078	PAD,TRAY 440 A VP-540
47	1000003079	PAD,TRAY 440 B VP-540
48	1000003080	PAD,TRAY 440 C VP-540
49	1000002692	PAD,U-LEFT VP-540
50	1000002693	PAD,U-RIGHT VP-540
51	22155133	PIPE,TOOL D9*L150 FJ-540
52	22055691	PLATE,LONG CLAMP MEDIA L SP-540V
53	22055693	PLATE,LONG CLAMP MEDIA R SP-540V
54	22055692	PLATE,SHORT CLAMP MEDIA L SP-540V
55	22055694	PLATE,SHORT CLAMP MEDIA R SP-540V
56	1000001602	SHEET,CLAMP MEDIA XC-540
57	1000002752	STICKER,REP JP/EN VP-540
58	22735135	STICKER,SUP JP/EN SP-300
59	1000002604	STOPPER,CARRIAGE VP-540
60	1000002700	TRAY,SKID VP-300
	1000002687	TRAY,SKID VP-540
61	12569656	TWEEZERS PTS-01

PARTS LIST -Supplemental Parts-

	Parts No.	Parts Name
S1	31279201	LABEL,REPACKAGE #LA16
S2	31139103	PLAPOINT,FE4*6 WH
S3	31049157	SCREW,CAP M6*20 3CBC+PW+SW
S4	31139104	SCREW,PLAPOINT M4*6 BK FE
S5	31229103AS	SCREW SET,TRUSS M2*6 NI 100 PCS

1-14 ACCESSORY (VP-540 : Above ZW65383, VP-300 : Above ZW61510)

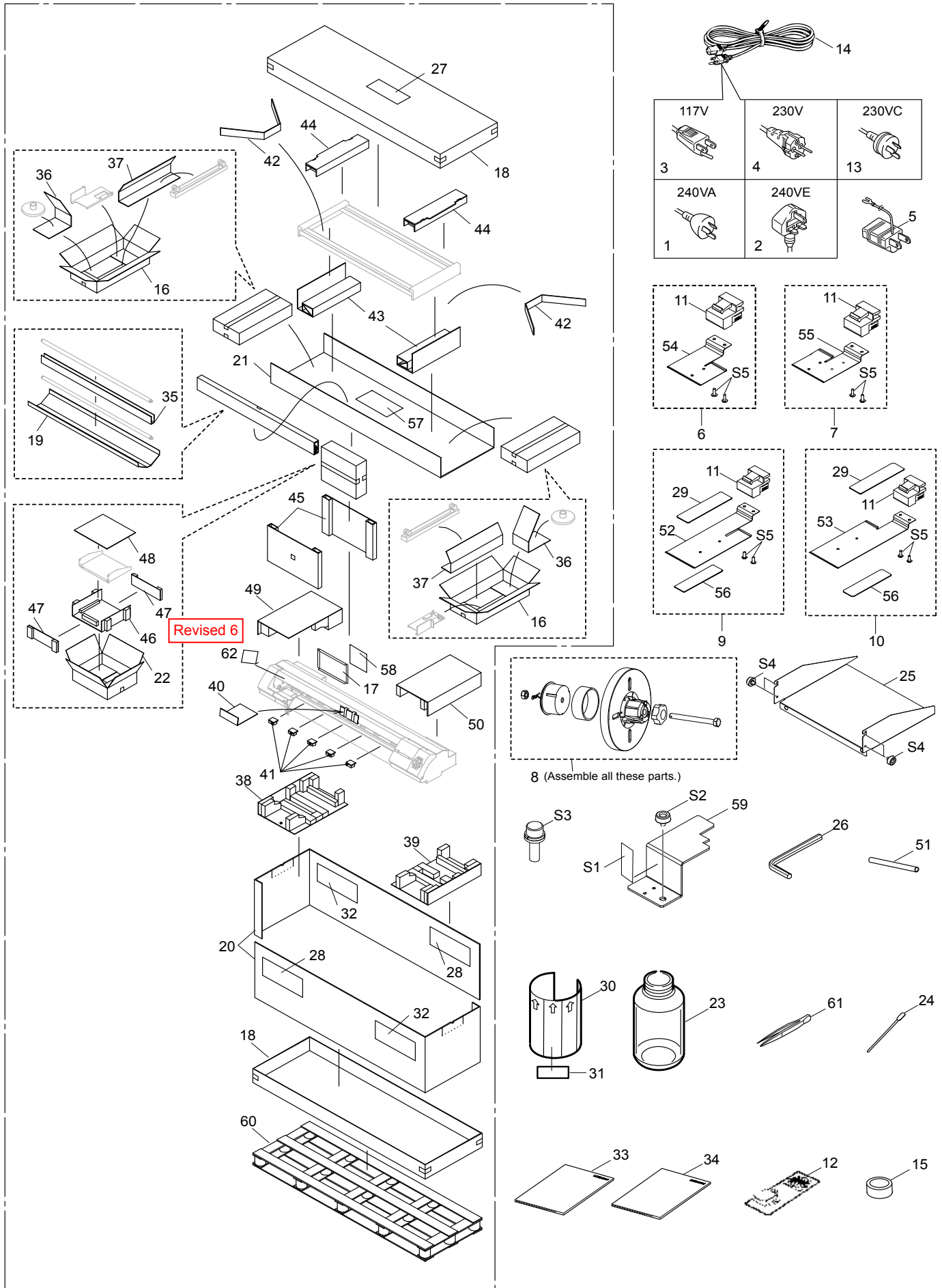

1-14 ACCESSORY (VP-540: Above ZW65383, VP-300: Above ZW61510)

PARTS LIST -Main Parts-

	Parts No.	Parts Name
1	23495124	AC CORD 3ASL100 240VA 10A SAA
2	13499111	AC CORD H05VV-F 240VE 10A S
3	13499109	AC CORD SJT 117V 10A 3PVC
4	23495125	AC-CORD H05VV 230V 10A S
5	13499209	ADAPTER PLUG (100V)
6	22805575	ASSY, SHORT MEDIA CLAMP L SP-540V
7	22805576	ASSY, SHORT MEDIA CLAMP R SP-540V
8	1000003083	ASSY,FLANGE GUIDE VP-540
9	6700469040	ASSY,MEDIA CLAMP L LONG VP-540
10	6700469050	ASSY,MEDIA CLAMP R LONG VP-540
11	22845112	BASE,MEDIA CLAMP SP-300
12	11849102	BLADE,OLFA AUTO CUTTER XB10
13	13439801	CABLE-AC 3P CHINA 10A250V S
14	23495117	CABLE-AC,VCTF 100V 12A 3P-S
15	22335143	CAP,EPDM
16	1000002698	CARTON,ACCESSORY VP-540
17	22605305	CARTON,COVER INK SP-300
18	1000002701	CARTON,COVER VP-300
	1000002688	CARTON,COVER VP-540
19	1000002704	CARTON,SHAFT SHEET VP-300
	1000002699	CARTON,SHAFT SHEET VP-540
20	1000002702	CARTON,SLEEVE VP-300
	1000002689	CARTON,SLEEVE VP-540
21	1000002703	CARTON,STAND VP-300
	1000002694	CARTON,STAND VP-540
22	1000003077	CARTON,TRAY 440 VP-540
23	11369115	CASE,PP BOTTLE
24	ST-037	CLEAN STICK TX712A
25	1000002650	COVER,440CC I/C VP-540
26	22565682	HEXAGONAL WRENCH 5
27	22535532	LABEL,CARTON CARE #LA762
28	1000002683	LABEL,CARTON VP-300#LA965
	1000002684	LABEL,CARTON VP-540#LA966
29	22535469	LABEL,CAUTION CLAMP SP-300#LA677
30	22535144	LABEL,DRAIN BOTTLE #LA29
31	1000001099	LABEL,HARMFUL FIRE #LA915
32	22535357	LABEL,USE FORKLIFT #LA435
33	1000002751	MANUAL,INS EN VP-540 MAX
	1000002749	MANUAL,INS JP VP-540 MAX
34	1000002750	MANUAL,USE EN VP-540 COMMON
	1000002748	MANUAL,USE JP VP-540 COMMON
35	1000003030	PAD, SHAFT SHEET VP-540
	1000003112	PAD,SHAFT SHEET VP-300
36	1000002968	PAD,ACCESSORY VP-540

PARTS LIST -Main Parts-

	Parts No.	Parts Name
37	1000003111	PAD,BASE STAND VP-540
38	1000002690	PAD,L-LEFT VP-540
39	1000002691	PAD,L-RIGHT VP-540
40	1000003110	PAD,RAIL UPPER VP-540
41	21545178	PAD,SPACER RAIL SP-300
42	1000002697	PAD,SPACER STAND VP-540
43	1000002695	PAD,STAND L/R VP-540
44	1000002696	PAD,STAND UPPER VP-540
45	1000002969	PAD,SUPPORT STAND VP-540
46	1000003078	PAD,TRAY 440 A VP-540
47	1000003079	PAD,TRAY 440 B VP-540
48	1000003080	PAD,TRAY 440 C VP-540
49	1000002692	PAD,U-LEFT VP-540
50	1000002693	PAD,U-RIGHT VP-540
51	22155133	PIPE,TOOL D9*L150 FJ-540
52	22055691	PLATE,LONG CLAMP MEDIA L SP-540V
53	22055693	PLATE,LONG CLAMP MEDIA R SP-540V
54	22055692	PLATE,SHORT CLAMP MEDIA L SP-540V
55	22055694	PLATE,SHORT CLAMP MEDIA R SP-540V
56	1000001602	SHEET,CLAMP MEDIA XC-540
57	1000002752	STICKER,REP JP/EN VP-540
58	22735135	STICKER,SUP JP/EN SP-300
59	1000002604	STOPPER,CARRIAGE VP-540
60	1000002700	TRAY,SKID VP-300
	1000002687	TRAY,SKID VP-540
61	12569656	TWEEZERS PTS-01
62	1000004192	PAD,COVER FRONT VP-540

Revised 6

PARTS LIST -Supplemental Parts-

	Parts No.	Parts Name
S1	31279201	LABEL,REPACKAGE #LA16
S2	31139103	PLAPOINT,FE4*6 WH
S3	31049157	SCREW,CAP M6*20 3CBC+PW+SW
S4	31139104	SCREW,PLAPOINT M4*6 BK FE
S5	31229103AS	SCREW SET,TRUSS M2*6 NI 100 PCS

2 Electrical Section

2-1 WIRING MAP

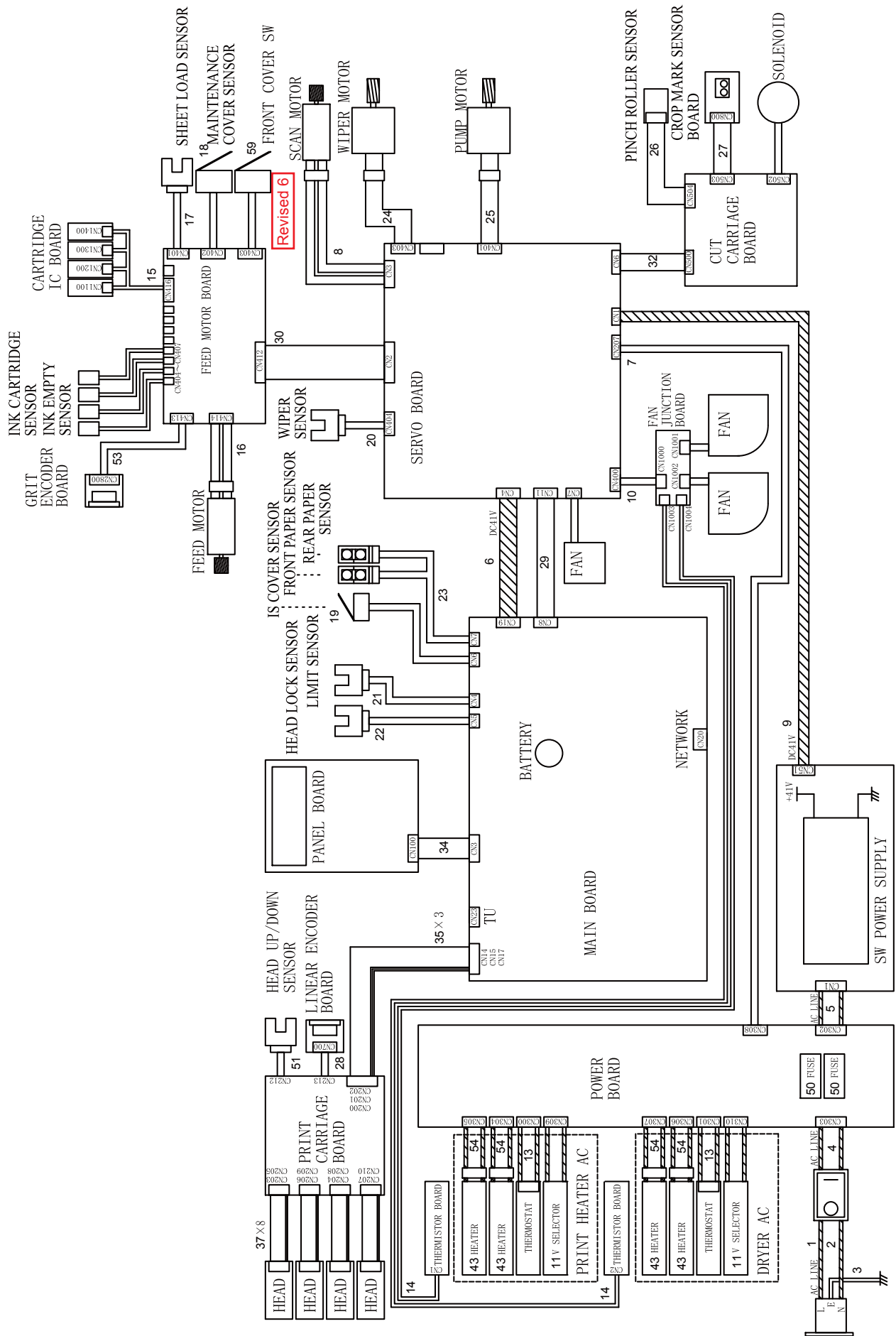

VP-540/300 WIRING MAP

Cable List

	Parts No.	Parts Name	VP-540		VP-300	
			100V	200V	100V	200V
1	1000002189	CABLE-ASSY,JUNBI A VP-540	*	*	*	*
2	1000002190	CABLE-ASSY,JUNBI B VP-540	*	*	*	*
3	23415268	CABLE-ASSY AC GROUND GREEN SP-540	*	*	*	*
4	23415116	CABLE ASSY,JUNBI D SP-300	*	*	*	*
5	1000002173	CABLE-ASSY,JUNBI E VP-540	*	*	*	*
6	1000002177	CABLE-ASSY,POWER SERVO VP-540	*	*	*	*
7	23415117	CABLE ASSY,POWER MAIN SP-300	*	*	*	*
8	1000002188	CABLE-ASSY,SCAN MOTOR VP-540	*	*	*	*
9	1000002180	CABLE-ASSY,RELAY JUNCTION VP-540	*	*	*	*
10	1000002168	CABLE-ASSY,FAN VP-540	*	*	*	*
11	1000002044	CABLE-ASSY,117V SELECTOR XC-540	*		*	
	1000002043	CABLE-ASSY,230V SELECTOR XC-540		*		*
13	1000002184	CABLE-ASSY,THERMOSTAT VP-540	*	*	*	*
14	1000002181	CABLE-ASSY,THERMISTOR VP-540	*	*	*	*
15	1000002172	CABLE-ASSY,INK CARTRIDGE VP-540	*	*	*	*
16	23415124	CABLE ASSY,GRIT MOTOR SP-300	*	*	*	*
17	1000002176	CABLE-ASSY,PINCH U/D SENSOR VP-540	*	*	*	*
18	23415114	CABLE ASSY,MNT. COVER SW SP-300	*	*	*	*
19	23505834	CABLE ASSY,INK SYSTEM COVER SW	*	*	*	*
20	1000002186	CABLE-ASSY,WIPER SENSOR VP-540	*	*	*	*
21	1000002167	CABLE-ASSY,CUT-CAR ORG VP-540	*	*	*	*
22	1000002178	CABLE-ASSY,PRI-CAR ORG VP-540	*	*	*	*
23	1000002175	CABLE-ASSY,PAPER SENSOR VP-540	*	*	*	*
24	1000002182	CABLE-ASSY,WIPER MOTOR VP-540	*	*	*	*
25	1000002179	CABLE-ASSY,PUMP MOTOR VP-540	*	*	*	*
26	1000002185	CABLE-ASSY,PINCH SENSOR VP-540	*	*	*	*
27	1000002187	CABLE-ASSY,CROP SENSOR VP-540	*	*	*	*
28	1000002174	CABLE-ASSY,LINEAR ENCODER VP-540	*	*	*	*
29	23475197	CABLE CARD 25P1 105L BB FJ-540	*	*	*	*
30	23475237	CABLE-CARD 40P1 2070L BB HIGH-V	*	*		
	23475216	CABLE CARD,40P1 1400L BB SP-300			*	*
32	23475238	CABLE-CARD, 15P1 2570L BB	*	*		
	23475207	CABLE CARD,15P1 1900L BB SP-300			*	*
34	23475212	CABLE-CARD,24P1 600L BB	*	*	*	*
35	23475240	CABLE CARD,36P1 2670L BB HIGH-V	*	*		
	23475213	CABLE CARD,36P1 2000L BB SP-300			*	*
37	23475206	CABLE-CARD 21P1 330L BB	*	*	*	*
43	1000002165	ASSY,CORD HEATER VP-540	*	*		
	1000002166	ASSY,CORD HEATER VP-300			*	*
50	12559105	FUSE	*	*	*	*
51	1000002171	CABLE-ASSY,HEAD U/D SENSOR VP-540	*	*	*	*
53	1000002169	CABLE-ASSY,GRIT ENCODER VP-540	*	*	*	*
54	1000002183	CABLE-ASSY,HEATER VP-540	*	*		
	1000002755	CABLE-ASSY,HEATER VP-300			*	*
59	1000004205	CABLE-ASSY, FRONT-COVER SW VP-540	*	*	*	*

Revised 6

2-2 MAIN BOARD

MAIN BOARD_Arrangement Diagram (Component Side)

It indicates the version of the Main Board.

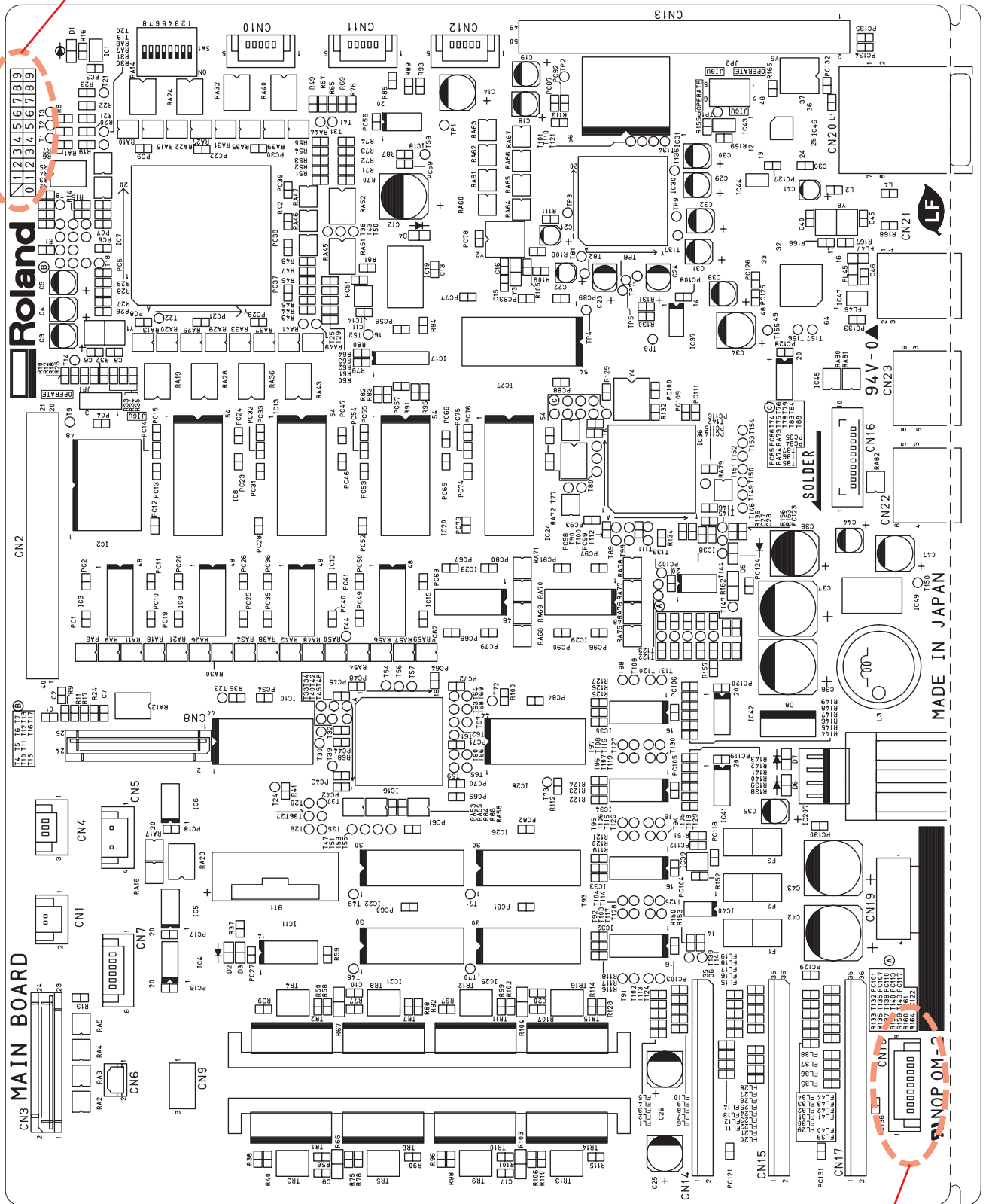

DP SW	Bit1	Bit2	Bit3	Bit4	Bit5	Bit6	Bit7	Bit8
VP-540	OFF	OFF	OFF	OFF	OFF	OFF	OFF	OFF
VP-300	OFF	OFF	OFF	OFF	OFF	OFF	OFF	OFF

MAIN BOARD_Circuit Diagram 1/9

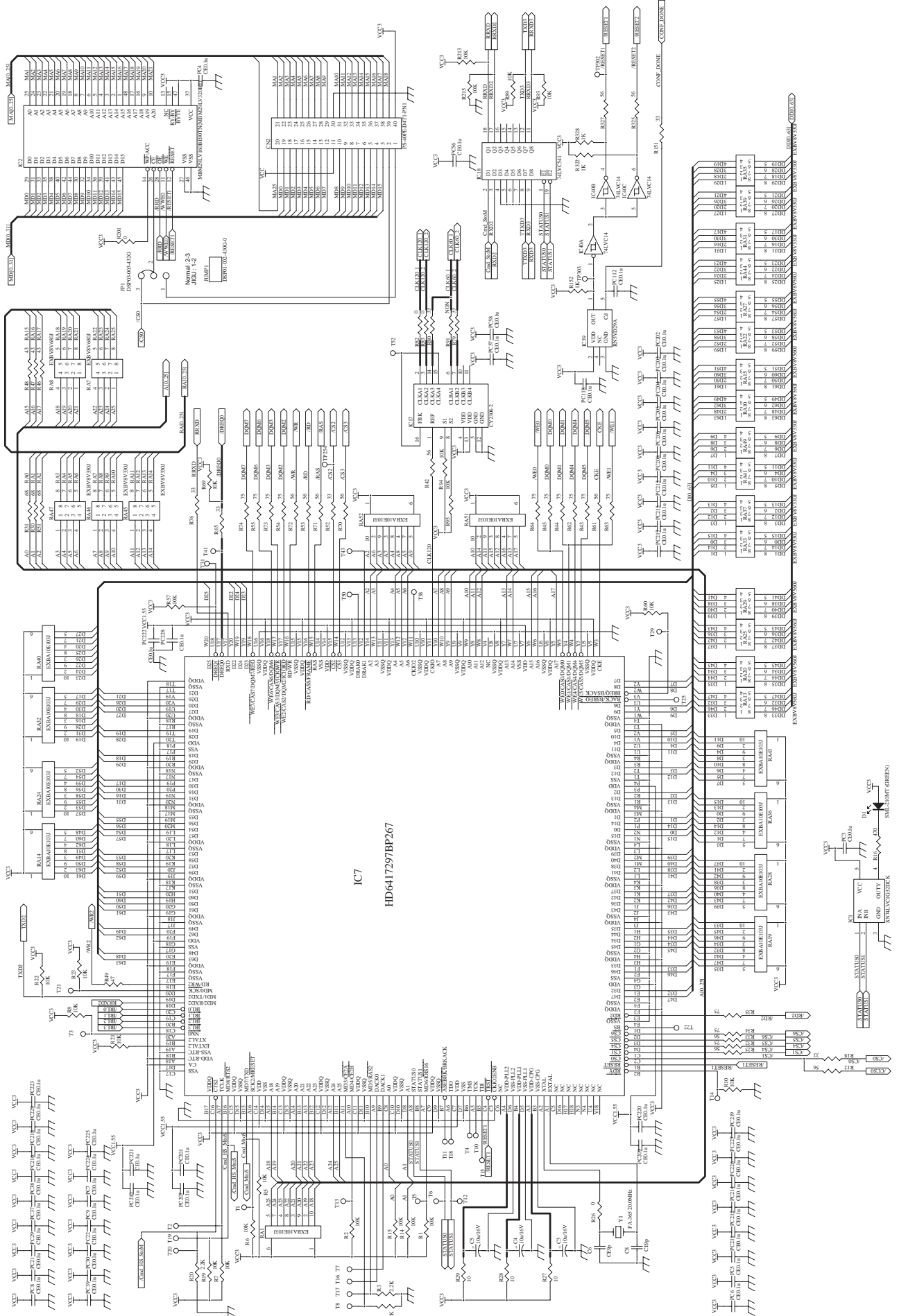

MAIN BOARD_Circuit Diagram 2/9

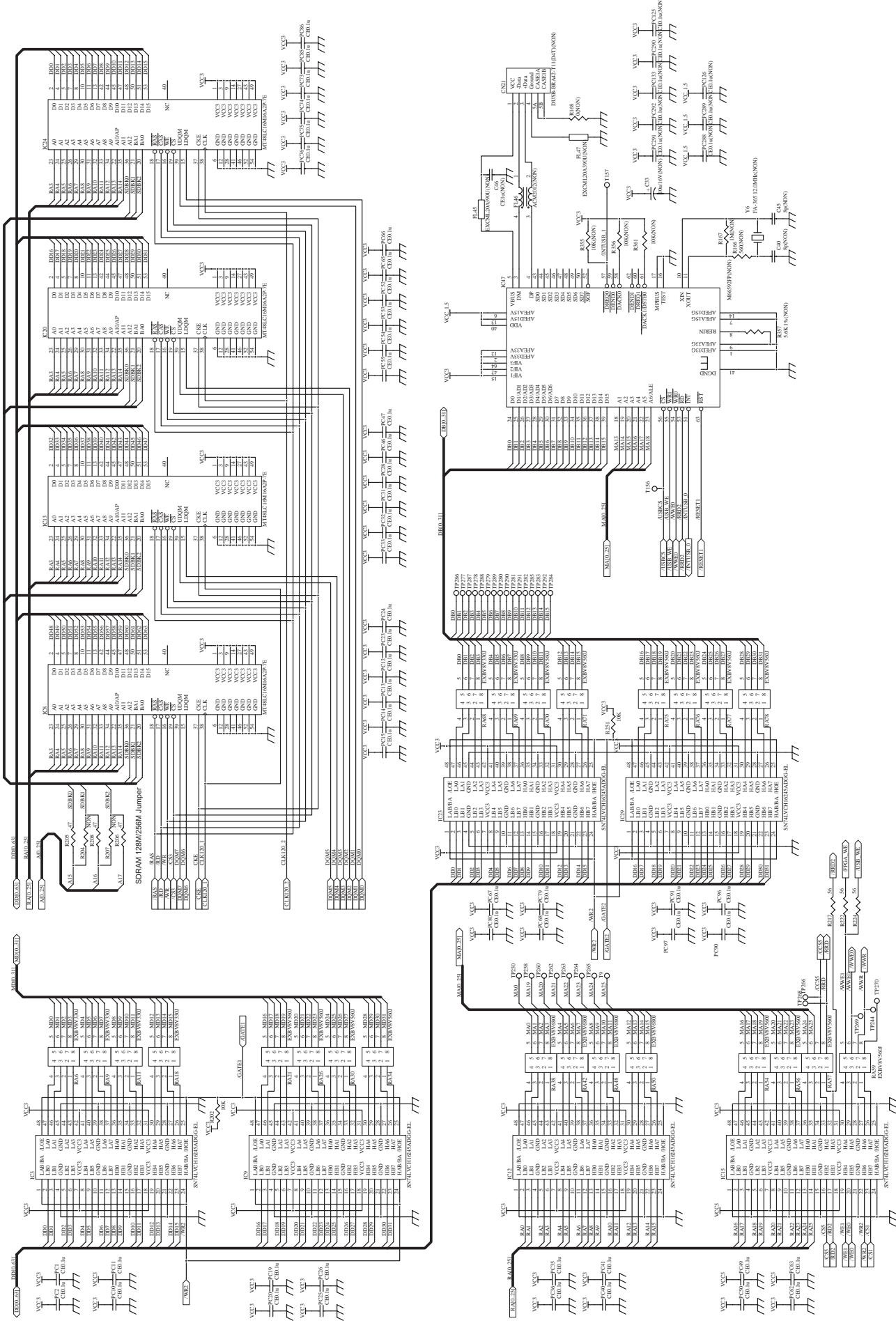

MAIN BOARD_Circuit Diagram 4/9

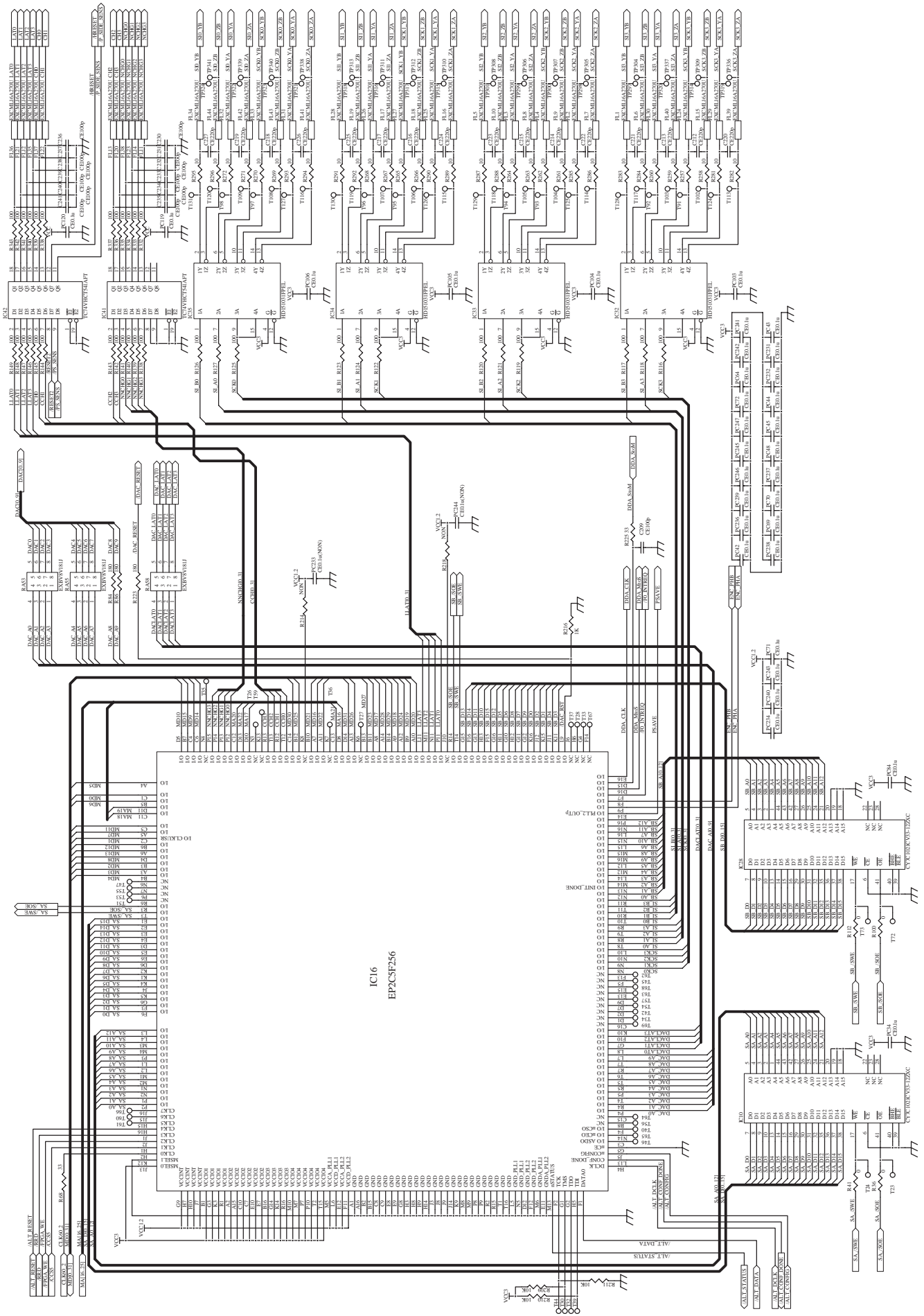

MAIN BOARD_Circuit Diagram 5/9

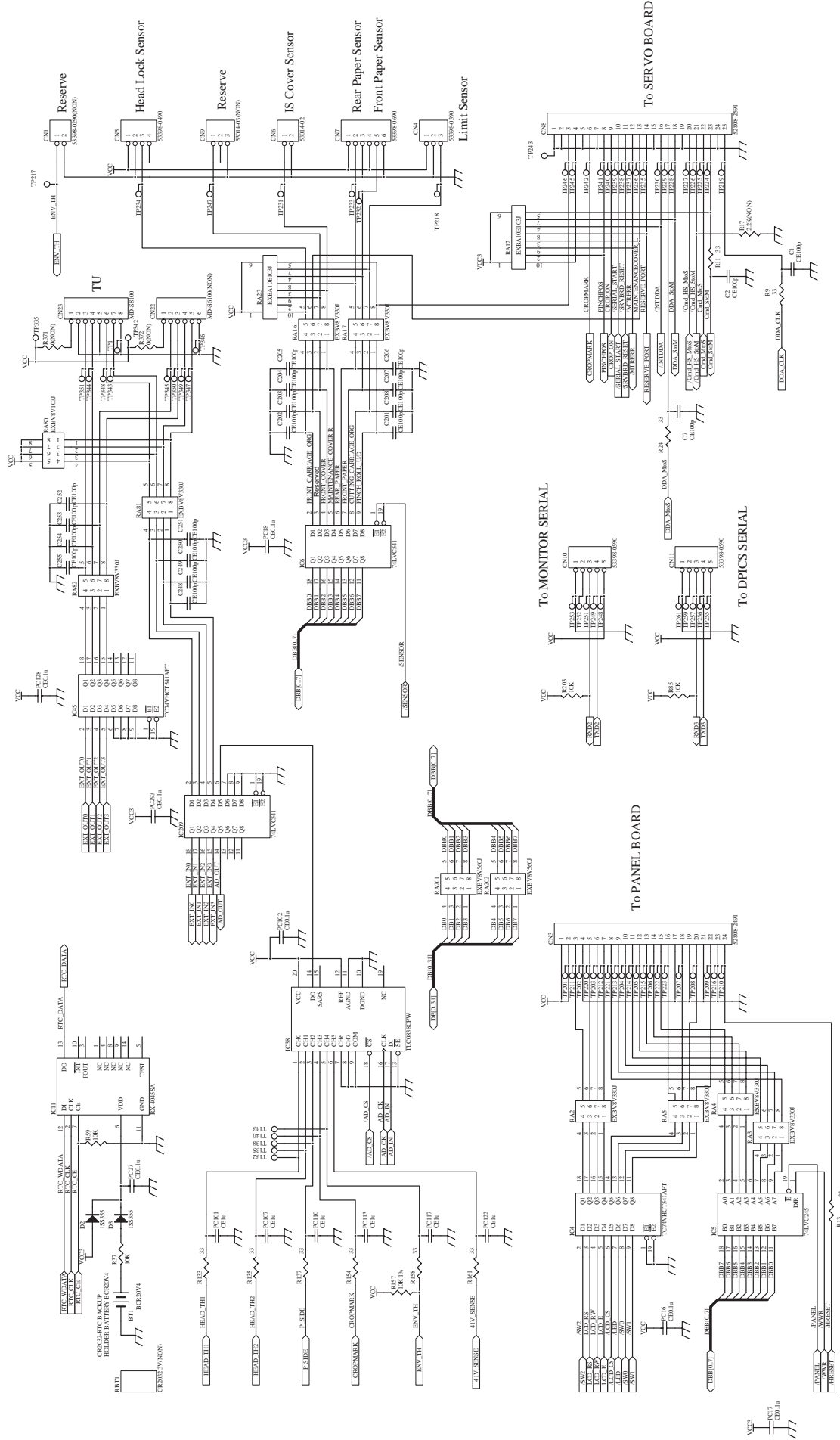

MAIN BOARD_Circuit Diagram 6/9

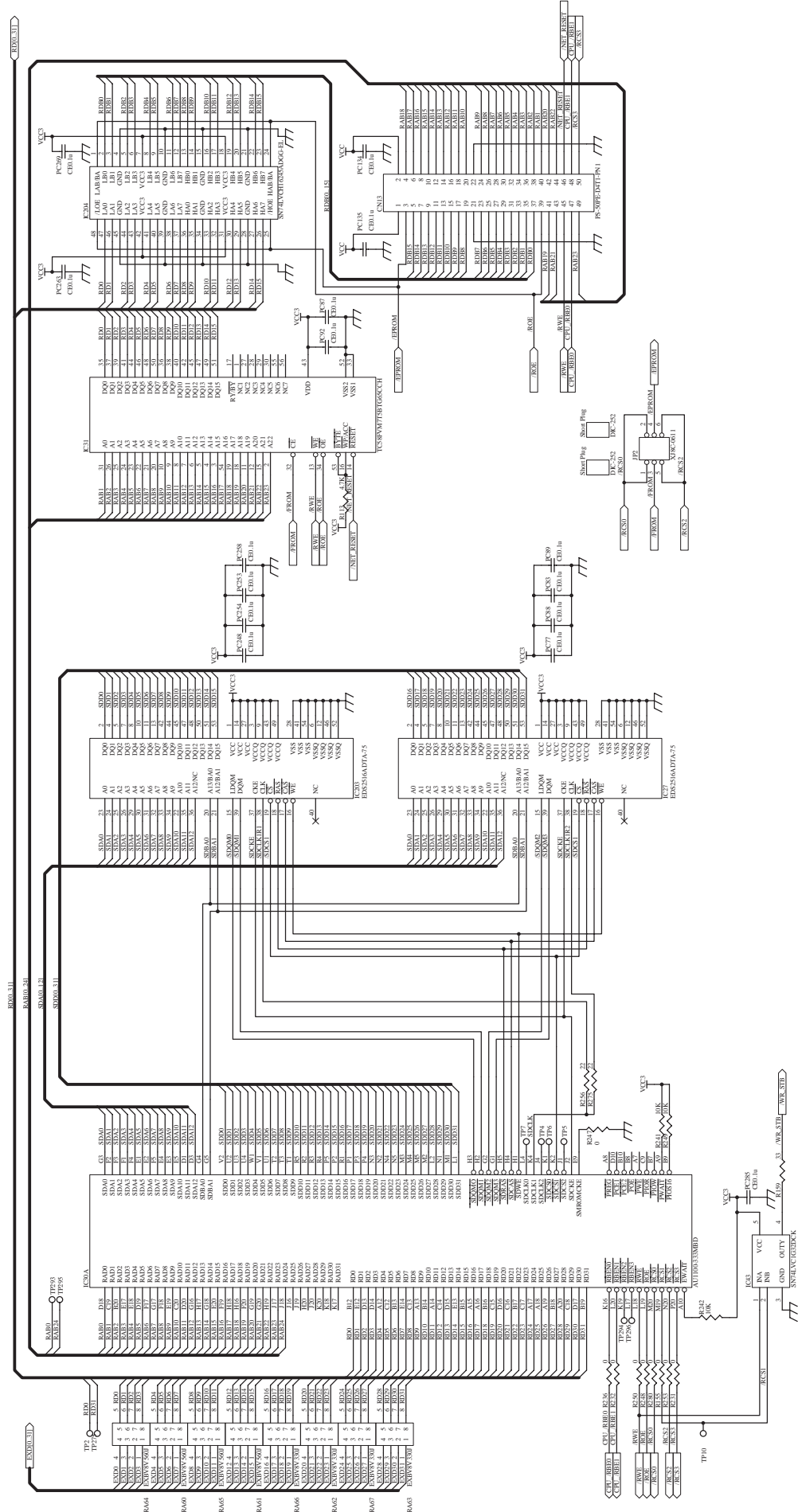

MAIN BOARD_Circuit Diagram 8/9

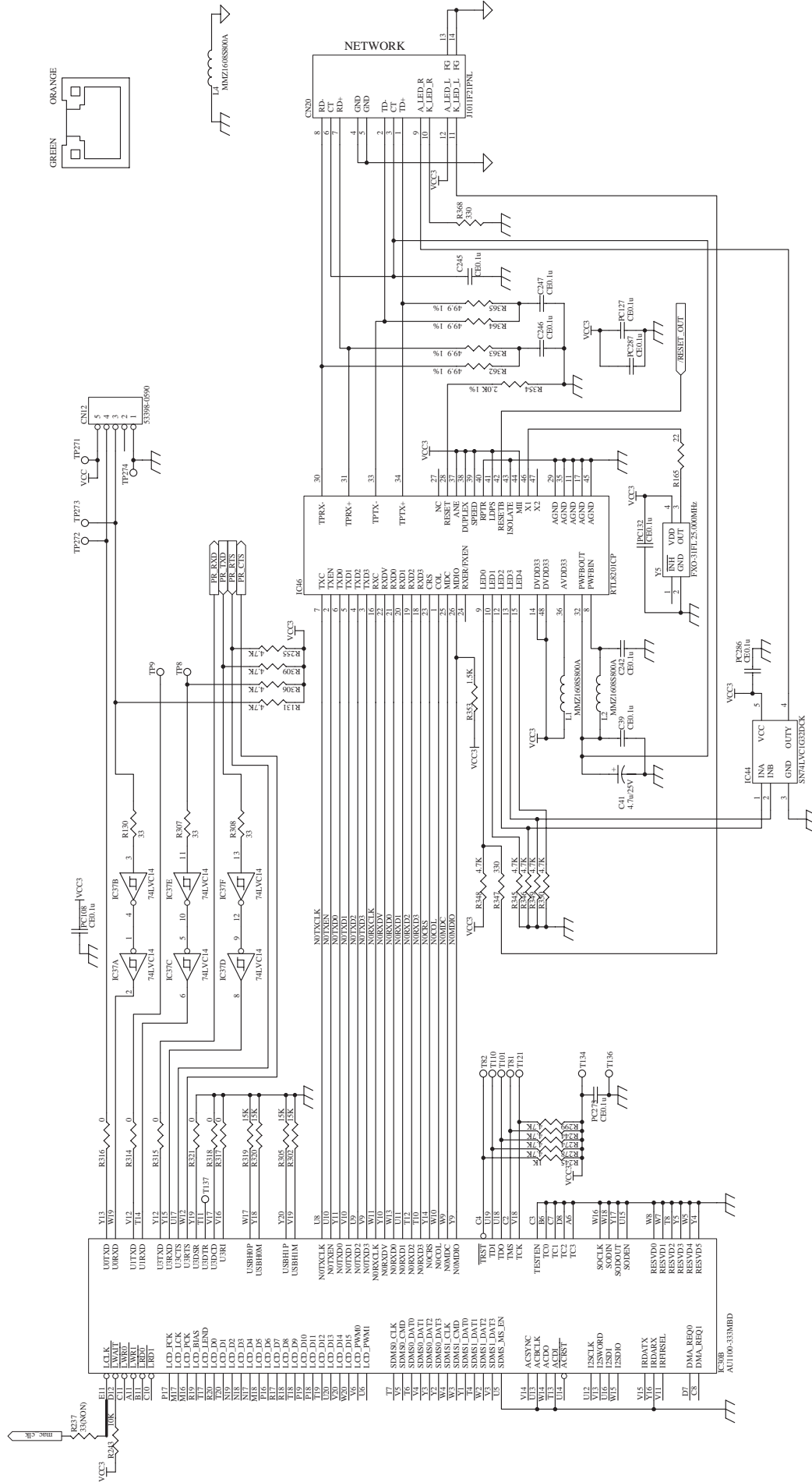

MAIN BOARD Circuit Diagram 9/9

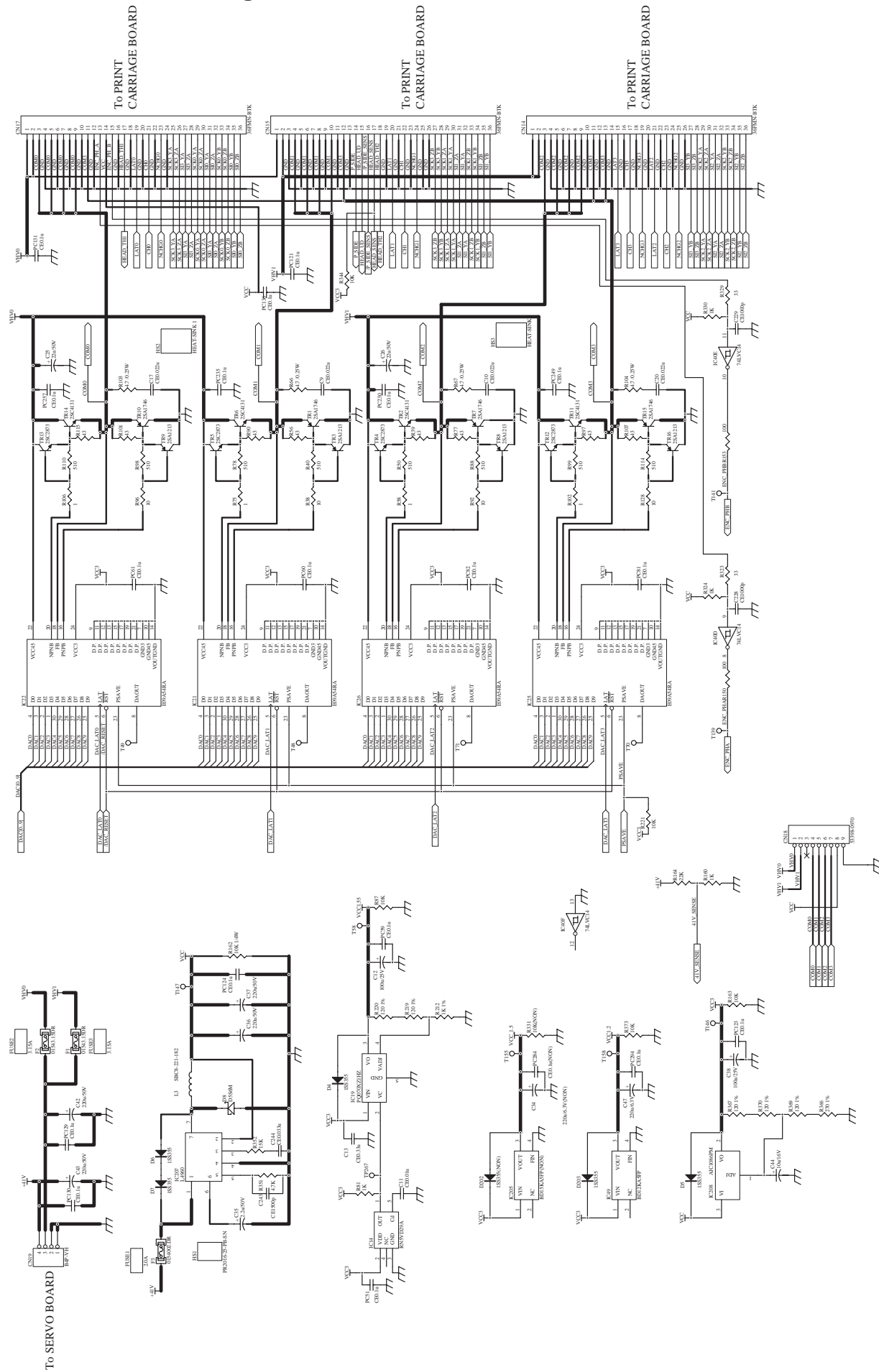

2-3 SERVO BOARD

SERVO BOARD_Arrangement Diagram (Component Side)

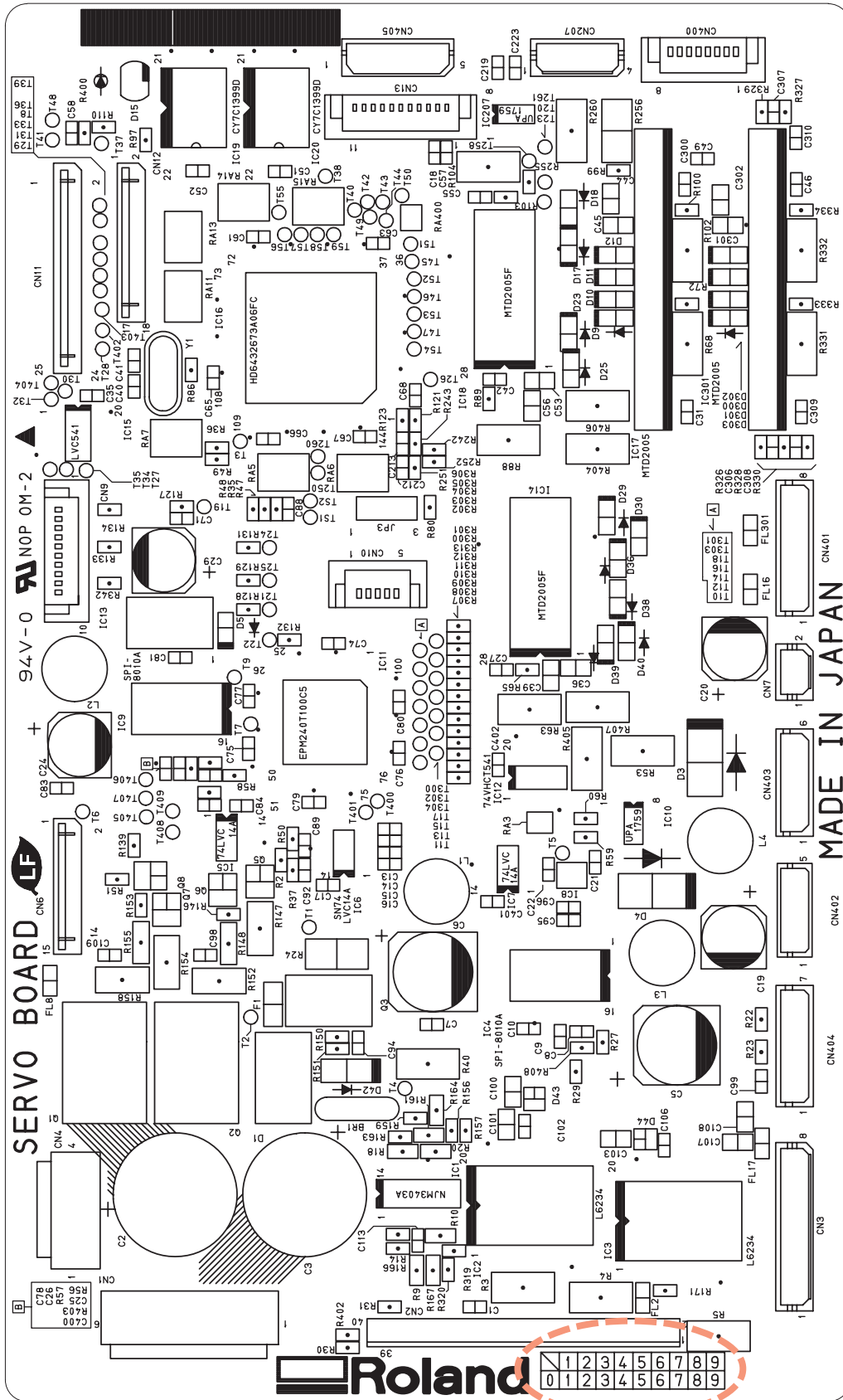

It indicates the version of the Servo Board.

SERVO BOARD_Arrangement Diagram (Soldering Side)

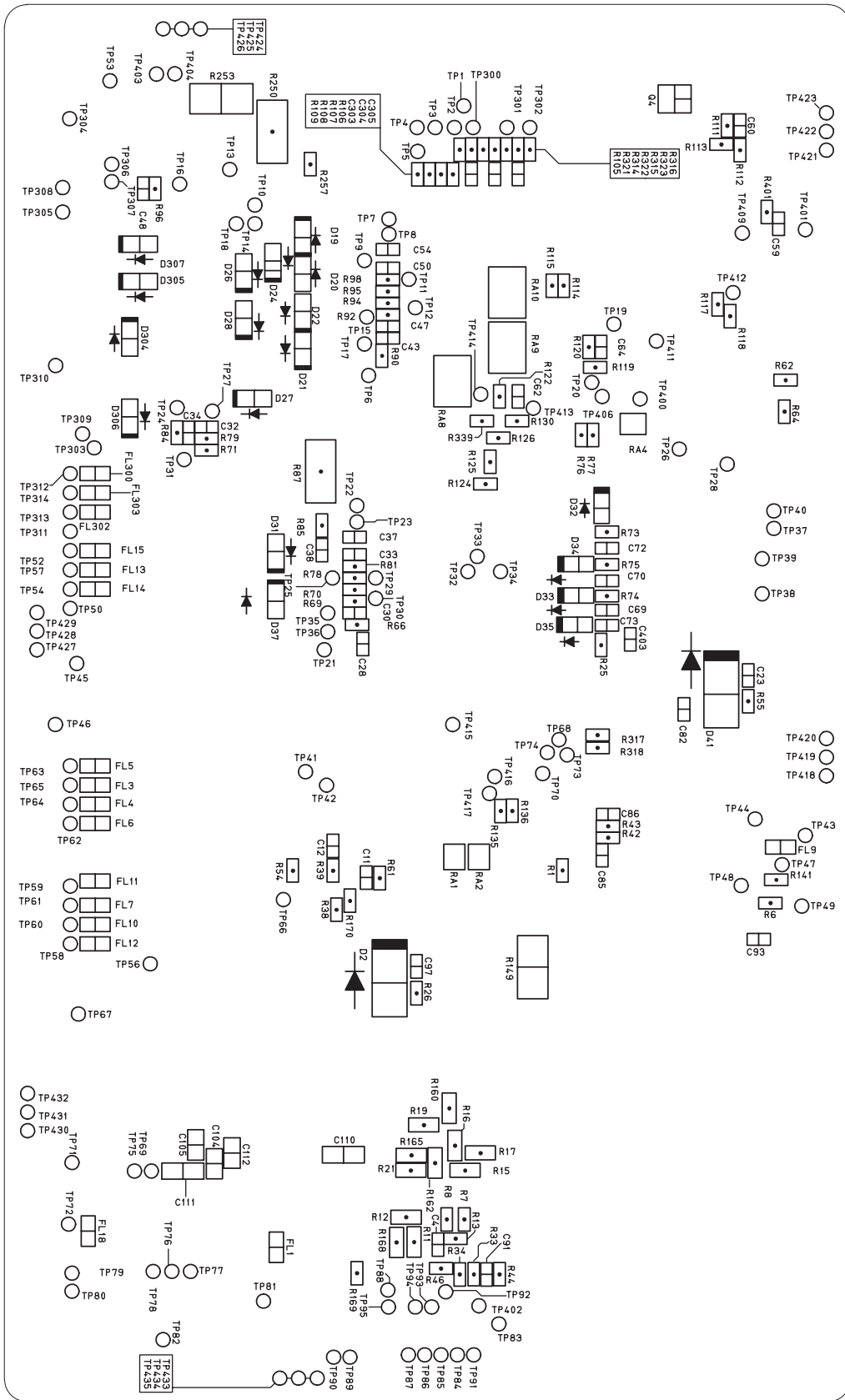

SERVO BOARD_Circuit Diagram 1/4

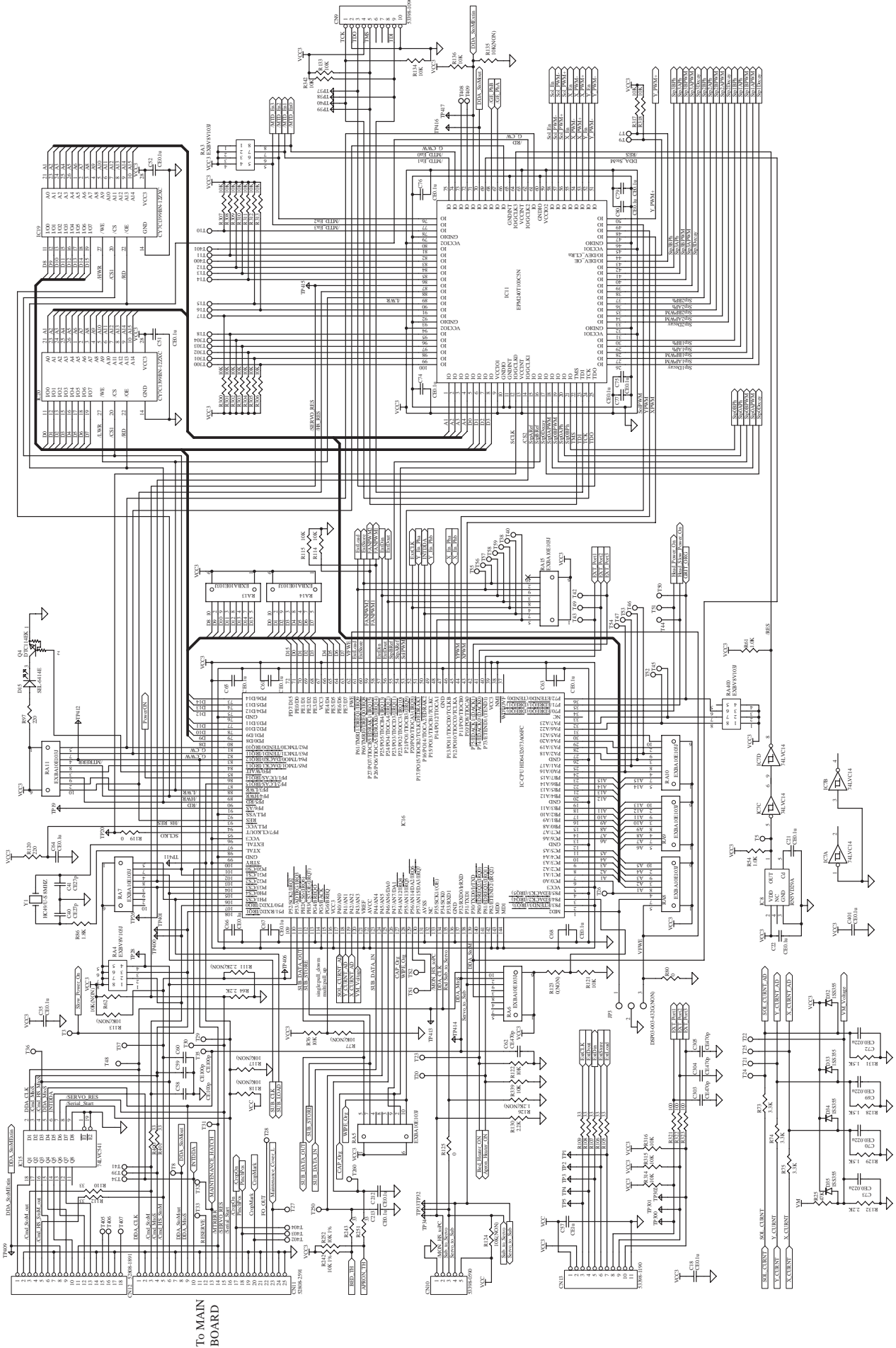

SERVO BOARD_Circuit Diagram 2/4

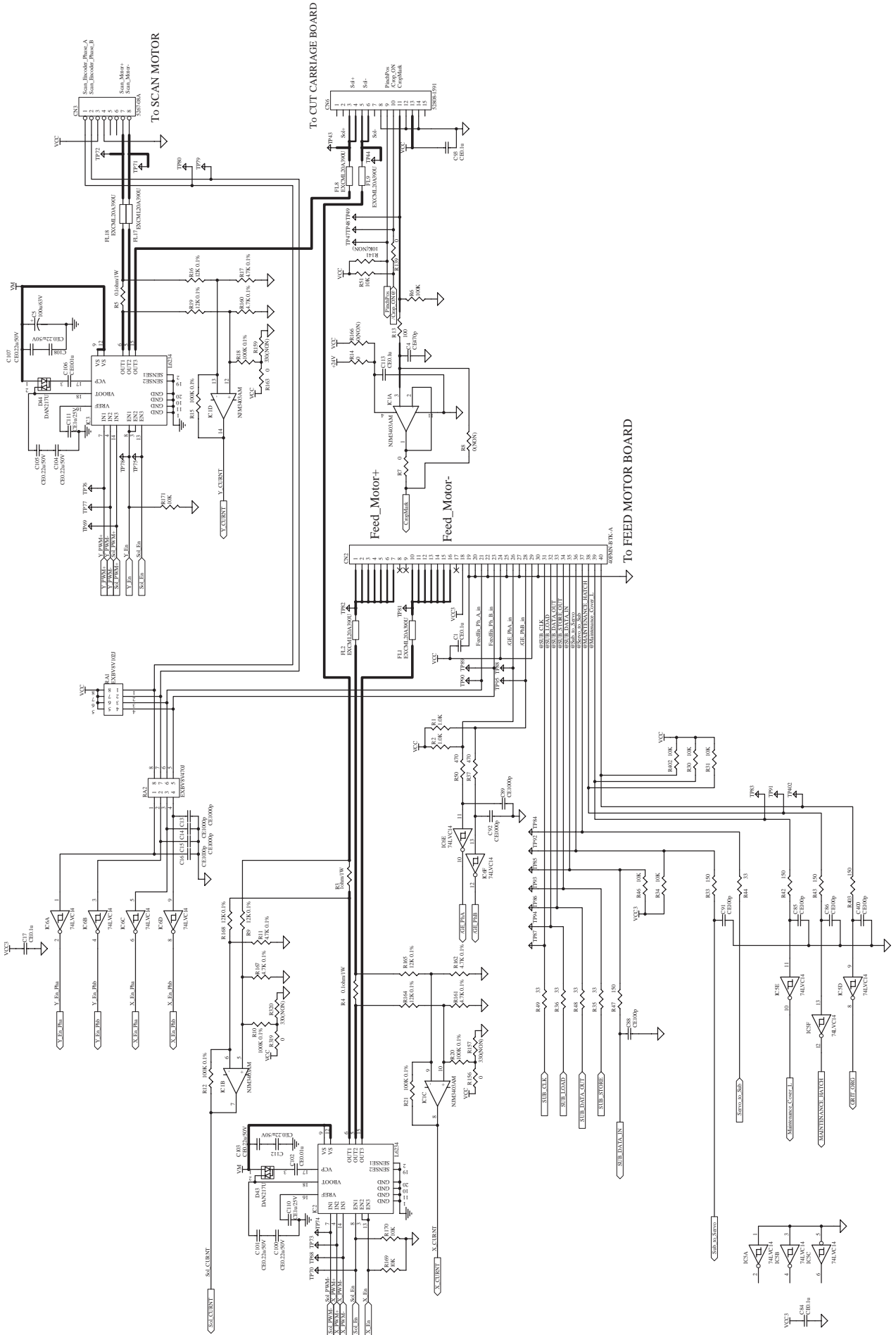

SERVO BOARD_Circuit Diagram 3/4

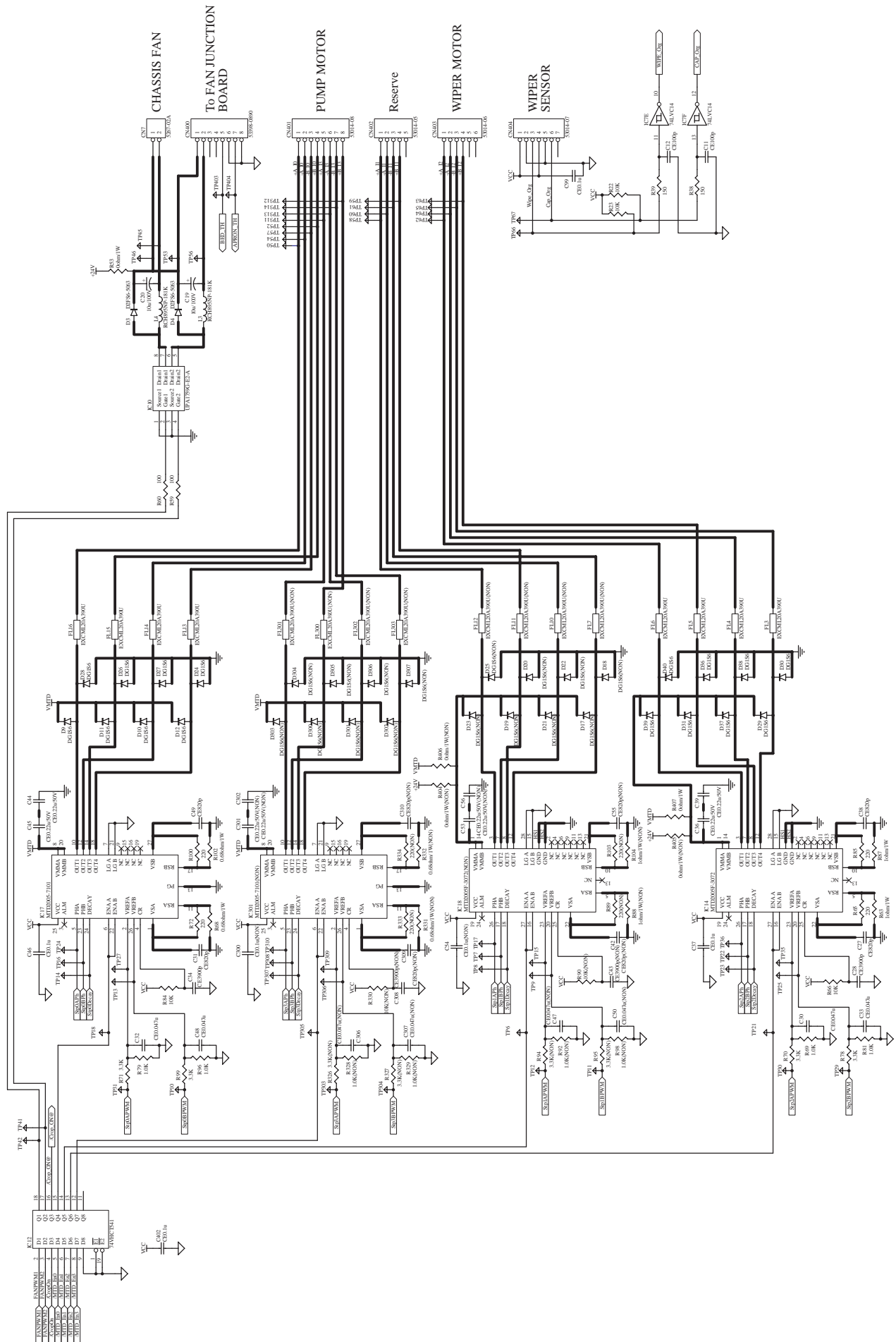

SERVO BOARD_Circuit Diagram 4/4

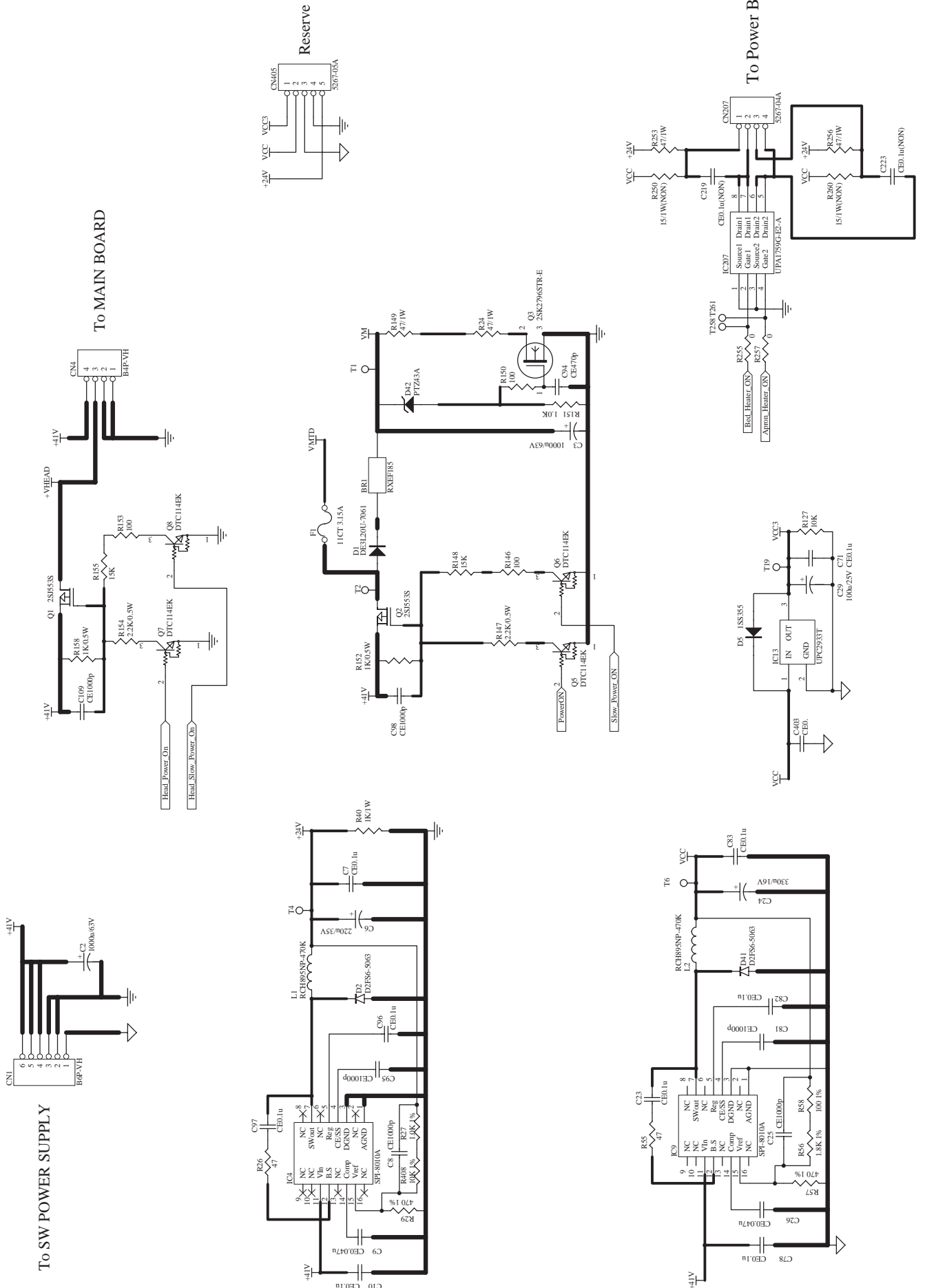

2-4 CARRIAGE BOARD

CARRIAGE BOARD_Arrangement Diagram (Component Side)

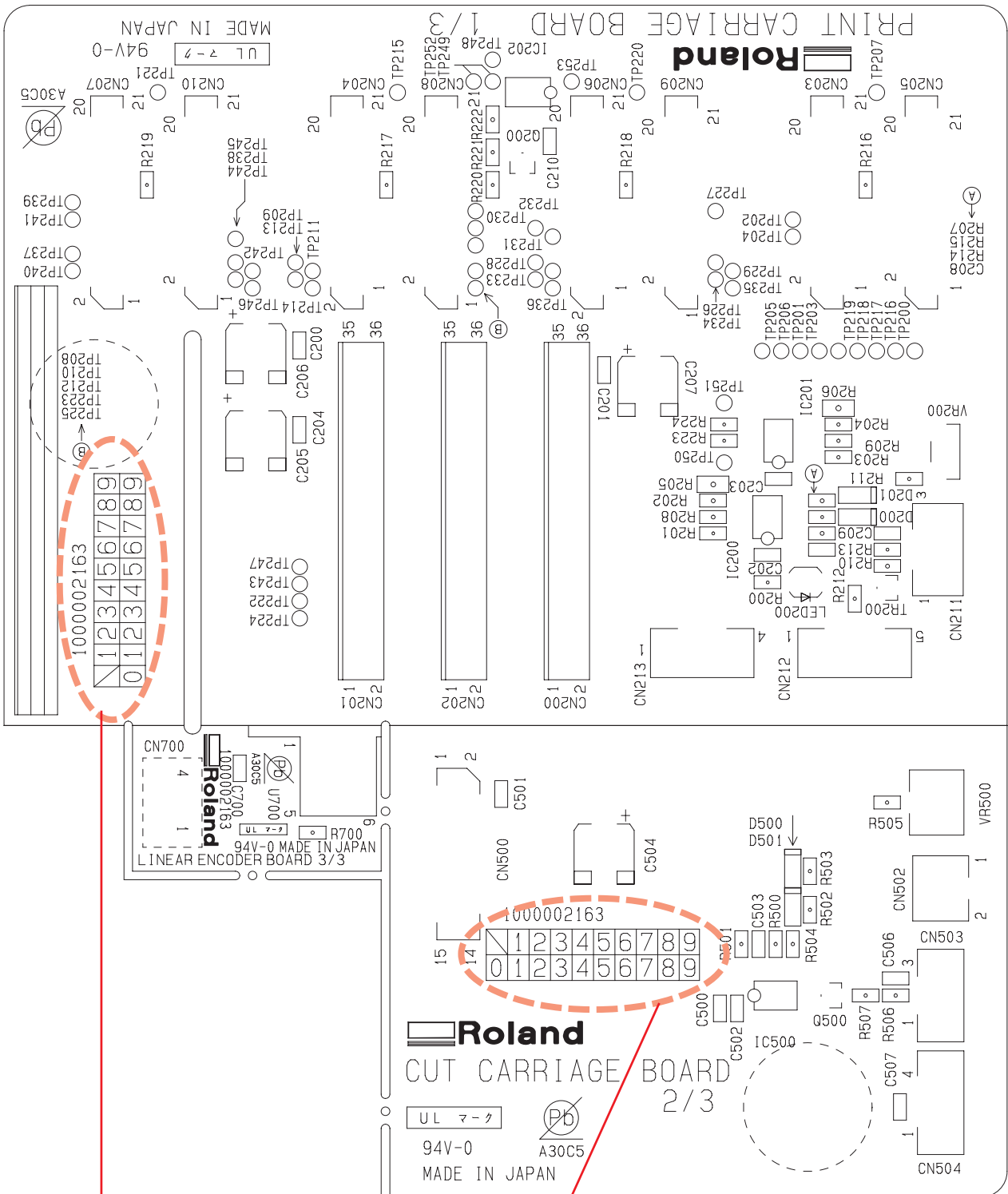

It indicates the version of the Carriage Board.

CARRIAGE BOARD_Circuit Diagram 1/2

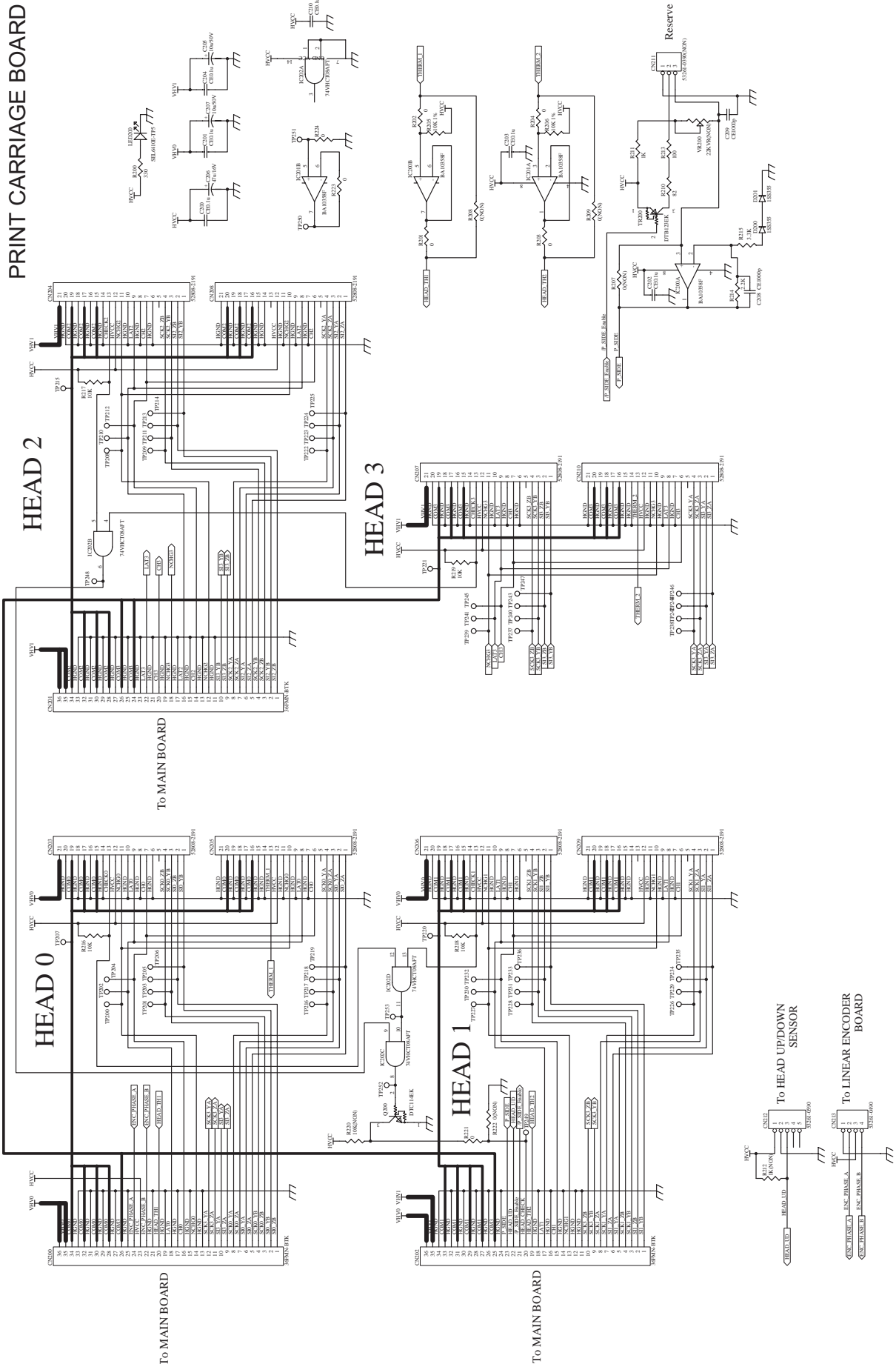

CARRIAGE BOARD_Circuit Diagram 2/2

CUT CARRIAGE BOARD

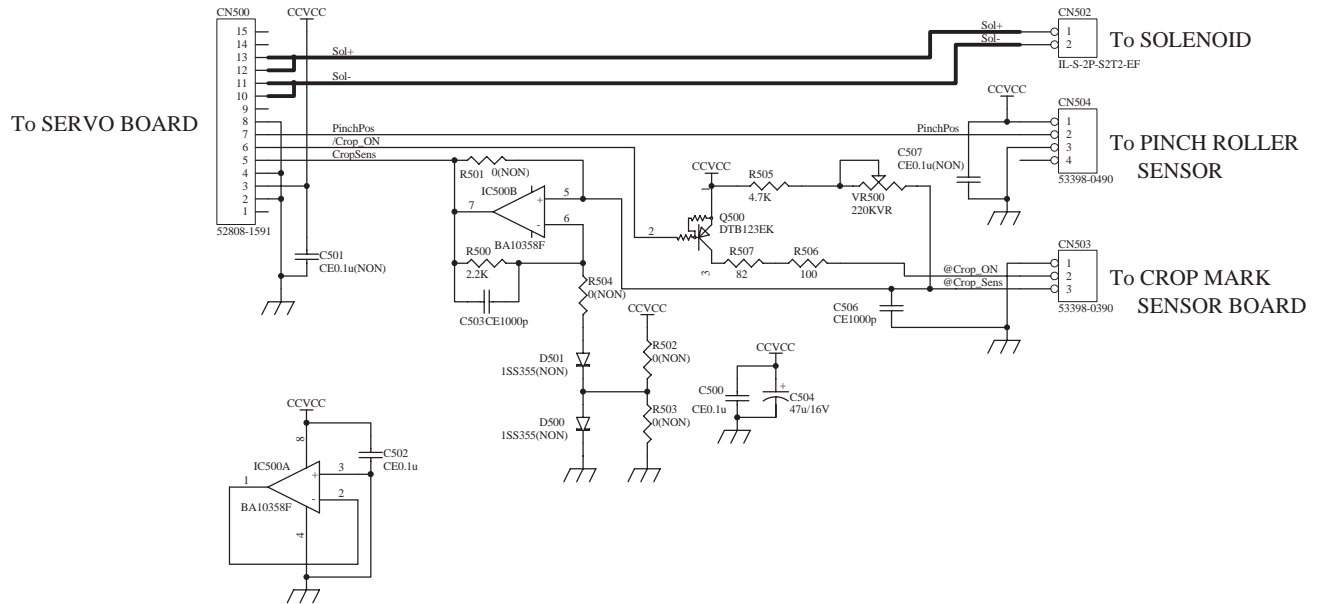

LINEAR ENCODER BOARD

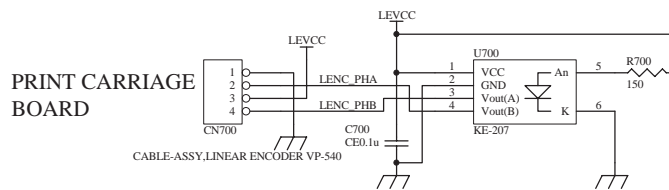

2-5 SUB BOARD

SUB BOARD_Arrangement Diagram (Component Side)

It indicates the version of the Board.

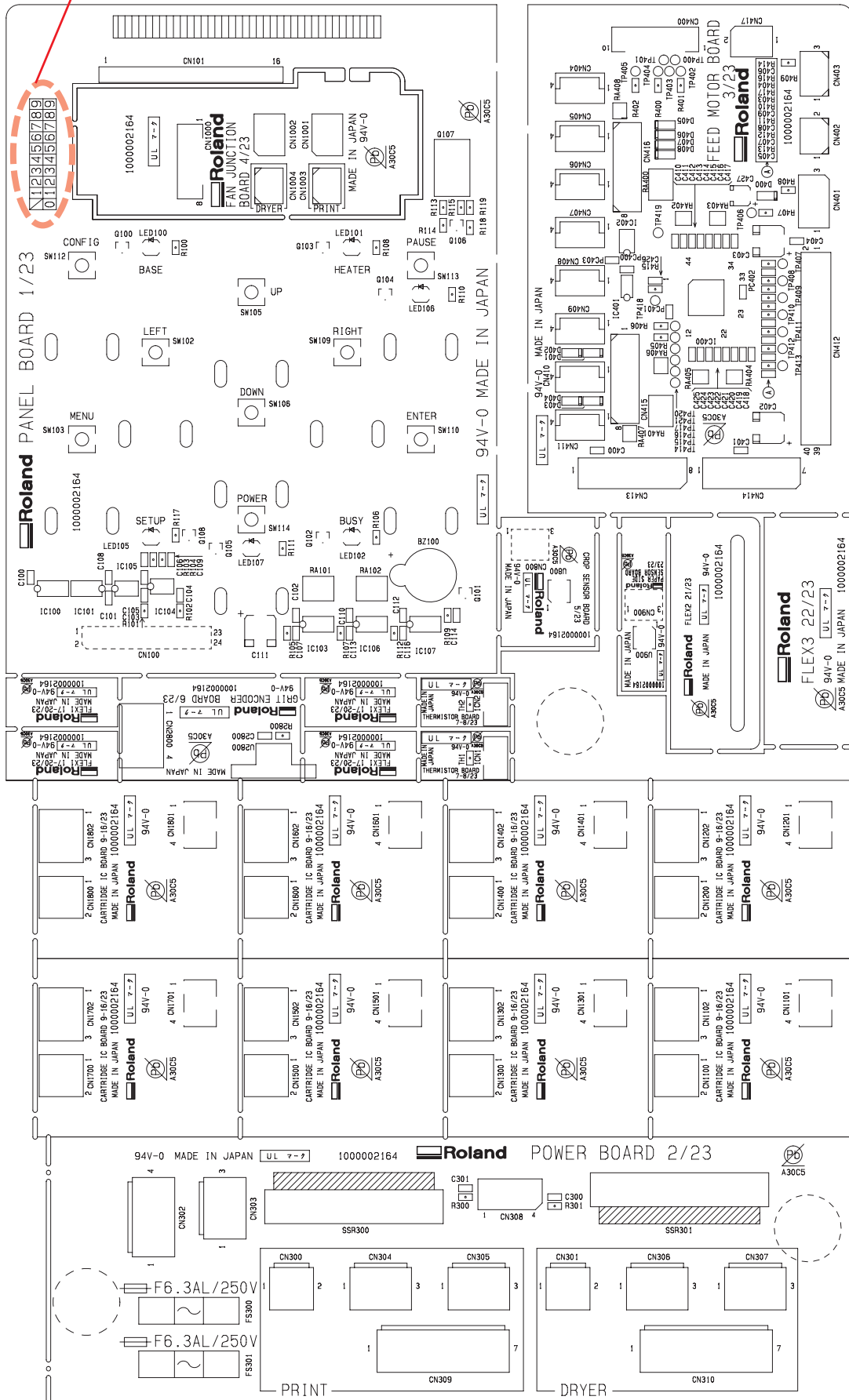

SUB BOARD_Circuit Diagram 1/4

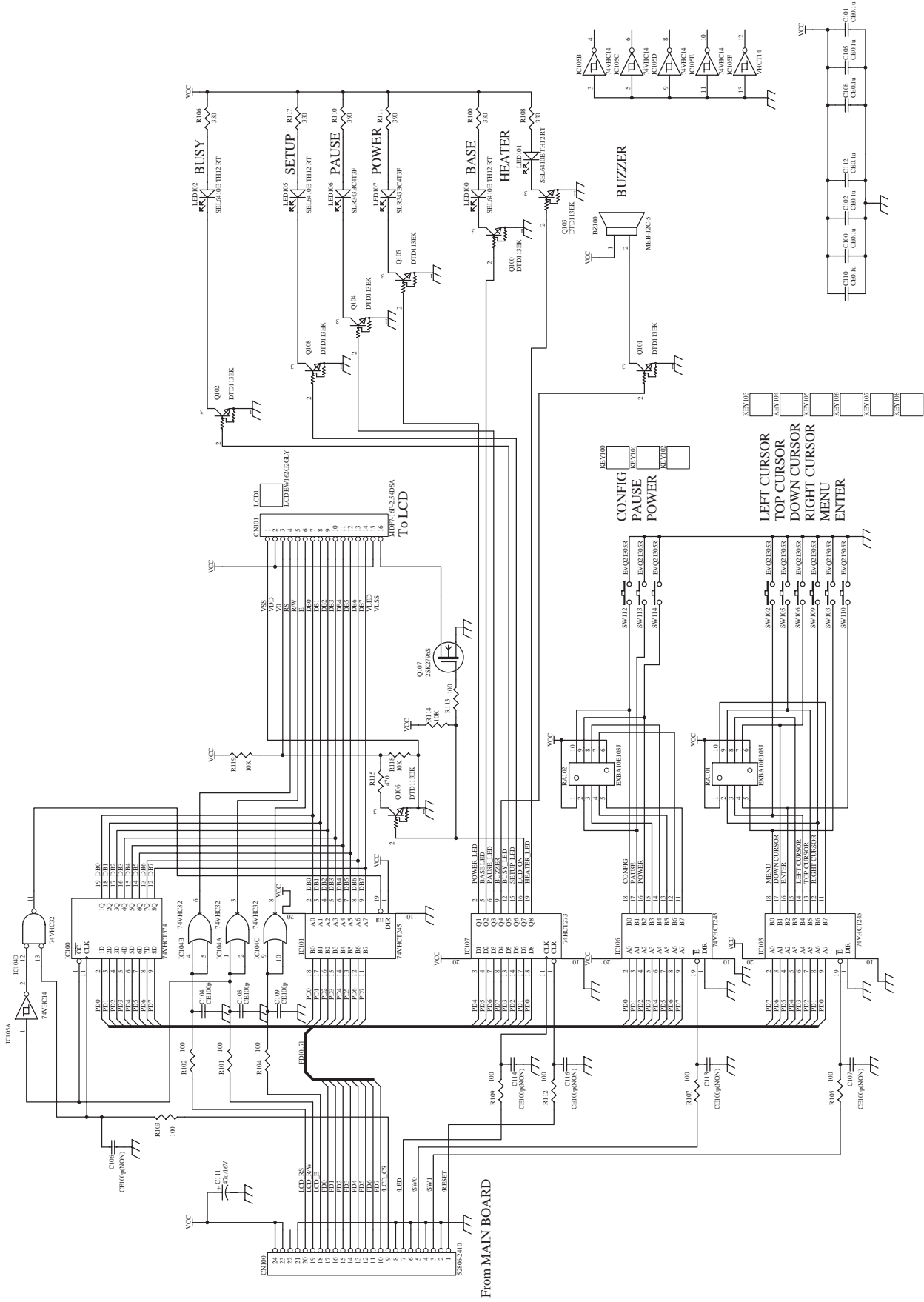

PANEL BOARD

SUB BOARD_Circuit Diagram 2/4

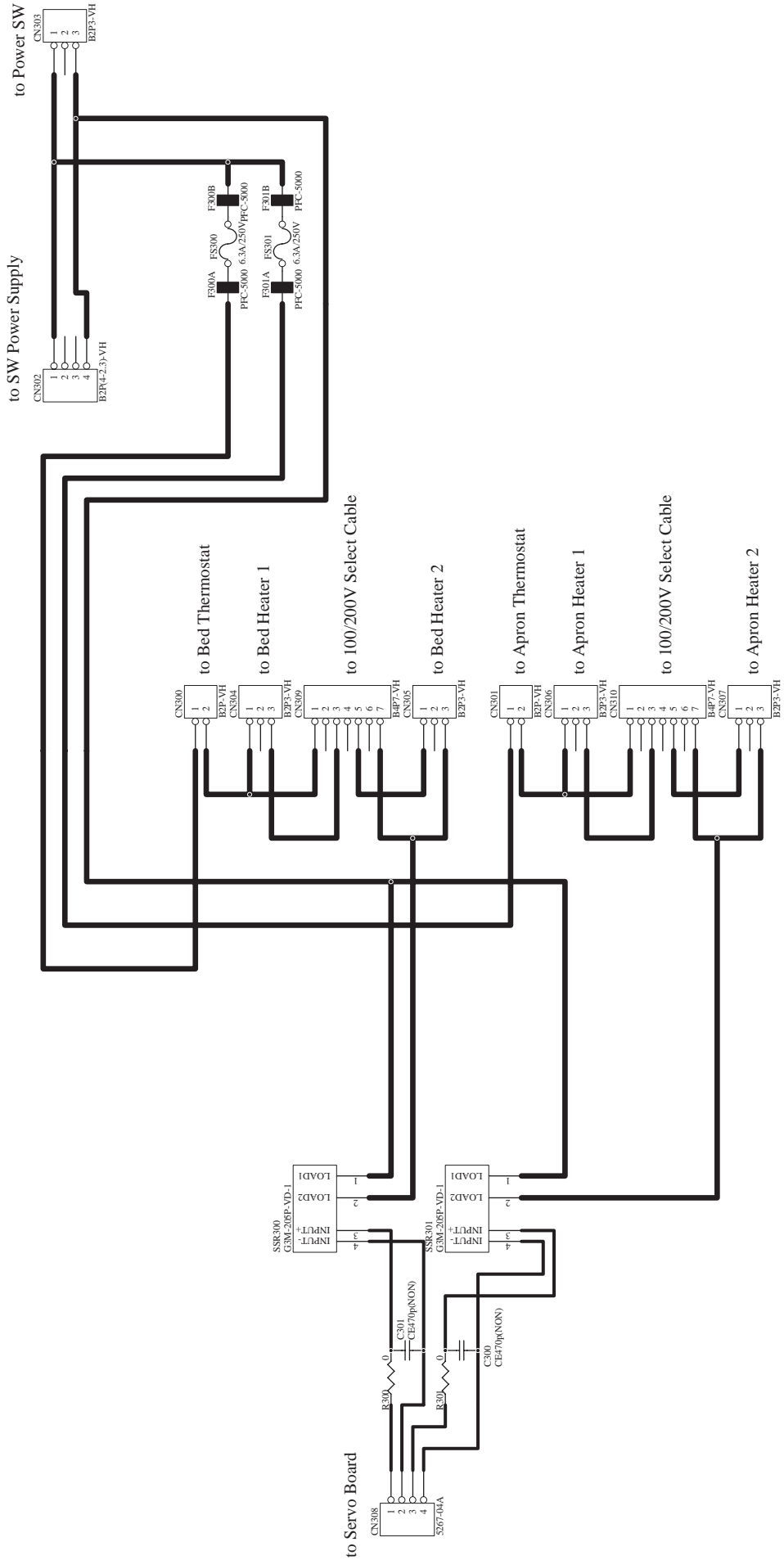

Power Board

SUB BOARD_Circuit Diagram 3/4

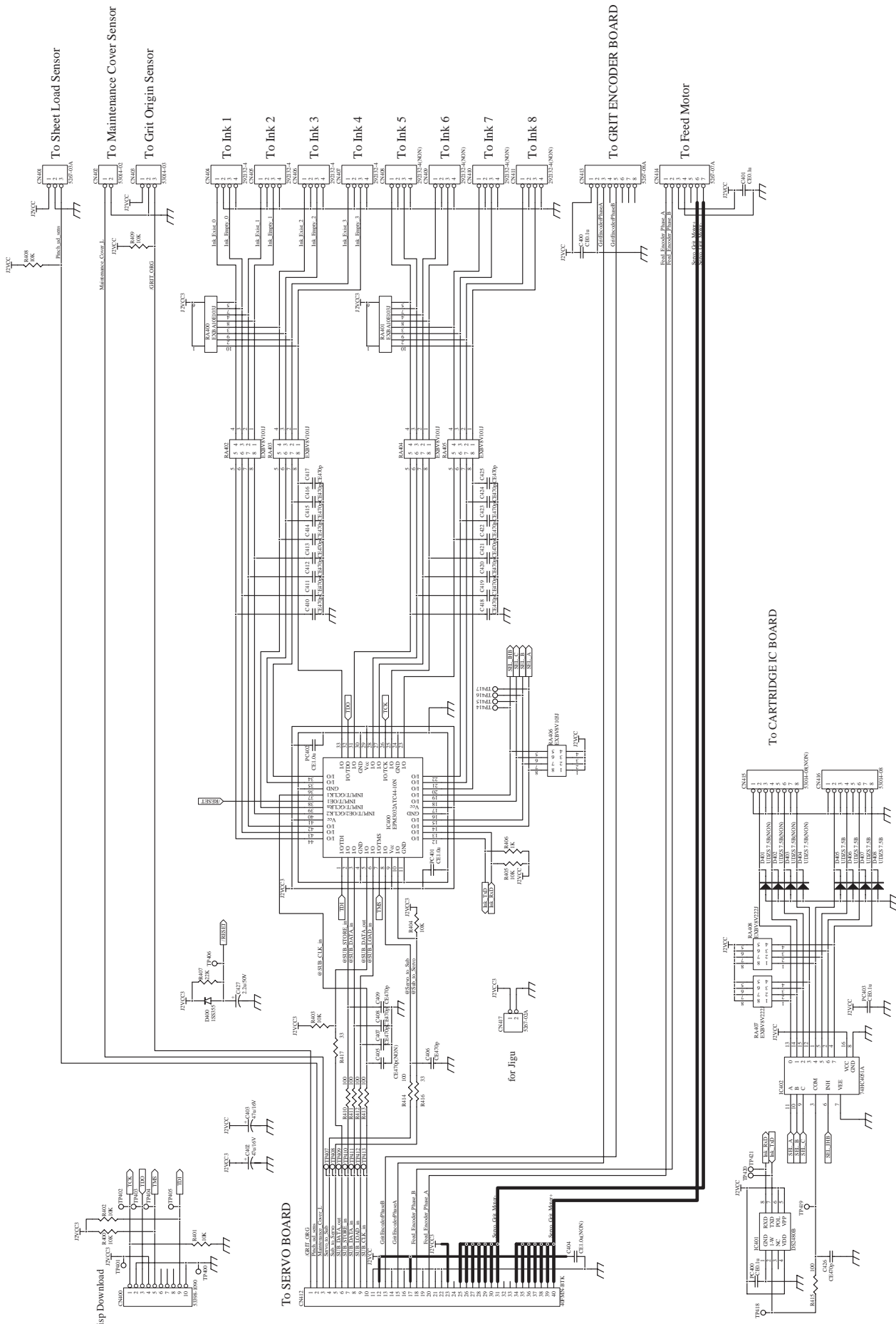

FEED MOTOR BOARD

SUB BOARD_Circuit Diagram 4/4

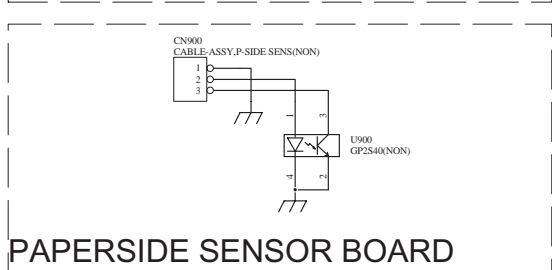
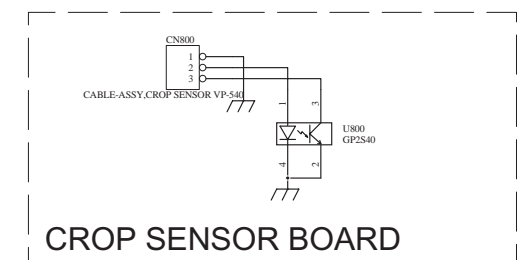
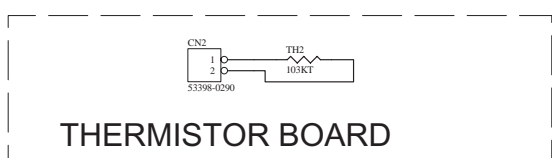
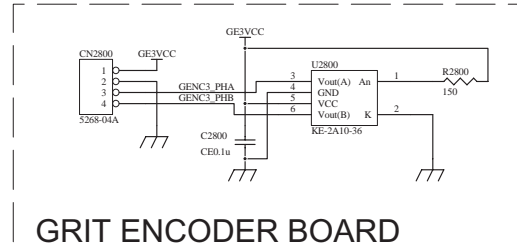
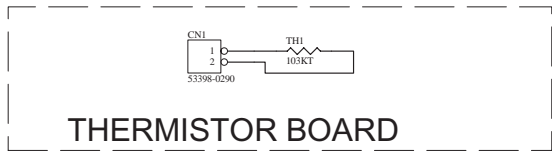
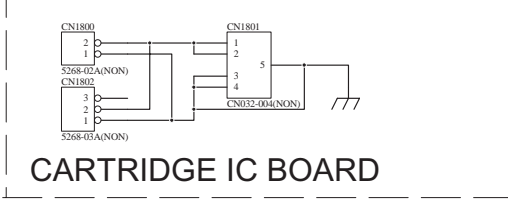
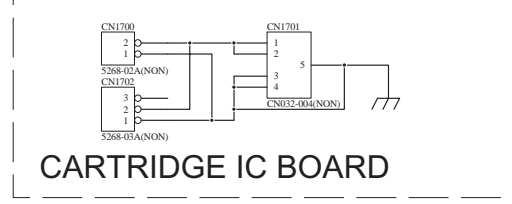
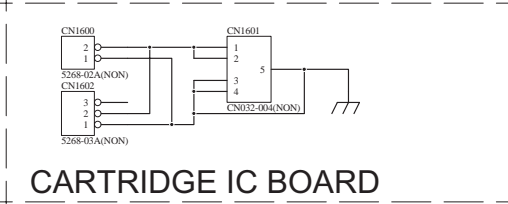
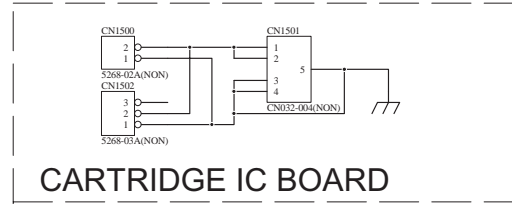
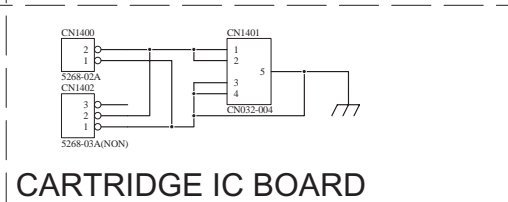
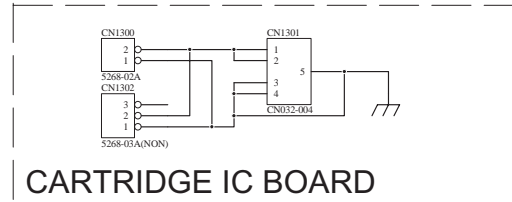
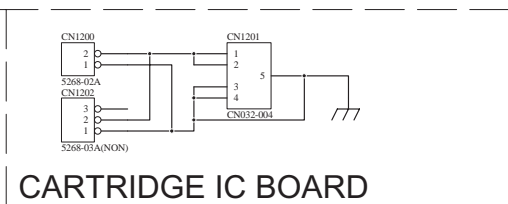
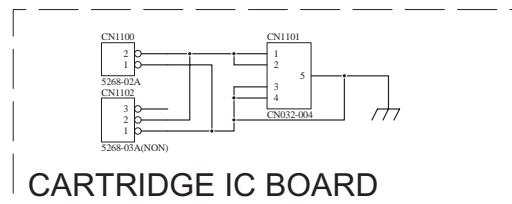
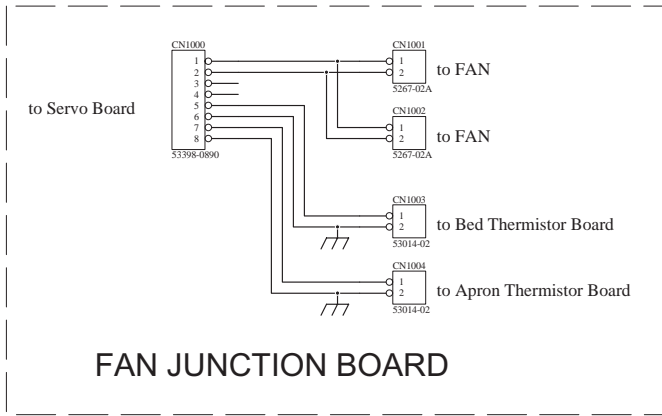

2-6 MAINTENANCE PARTS LIST _ Electrical Parts

MAIN BOARD

IC No.	Parts No.	Description	Function
IC207	15199237	V.RGL L4960	5V Regulator
IC22	1000001098	IC,E09A54RA	D/A Converter for Head BK
IC21	1000001098	IC,E09A54RA	D/A Converter for Head CY
IC26	1000001098	IC,E09A54RA	D/A Converter for Head MG
IC25	1000001098	IC,E09A54RA	D/A Converter for Head YE
TR14	15129122	TR 2SC4131 GB	Transistor for Driving HEAD BK
TR10	15129121	TR 2SA1746 OY	Transistor for Driving HEAD BK
TR6	15129122	TR 2SC4131 GB	Transistor for Driving HEAD CY
TR1	15129121	TR 2SA1746 OY	Transistor for Driving HEAD CY
TR2	15129122	TR 2SC4131 GB	Transistor for Driving HEAD MG
TR7	15129121	TR 2SA1746 OY	Transistor for Driving HEAD MG
TR11	15129122	TR 2SC4131 GB	Transistor for Driving HEAD YE
TR15	15129121	TR 2SA1746 OY	Transistor for Driving HEAD YE
F2	1000000659	FUSE,01543.15DR	Fuse for Head BK&CY
F1	1000000659	FUSE,01543.15DR	Fuse for Head MG&YE
F3	1000003014	FUSE,154002.DR	Fuse for 41V

SERVO BOARD

IC No.	Parts No.	Description	Function
IC17	15189105	IC-LINEAR,MTD2005-7101	Pump Motor Driver
IC14	15189111	IC-LINEAR,MTD2005F-3072	Wipe Motor Driver
IC10	15119119	TR,MOS UPA1759G-E2-A	Fan Driver
IC207	15119119	TR,MOS UPA1759G-E2-A	Relay Driver
F1	12559102	FUSE 11CT 3.15A	Fuse for Step Motor Driver

POWER BOARD

IC No.	Parts No.	Description	Function
FS300	12559105	FUSE,5X20 021706.3MXP 6.3A/250V	Fuse for Print Heater
FS301	12559105	FUSE,5X20 021706.3MXP 6.3A/250V	Fuse for Dryer
SSR300	1000000164	RELAY,SSR G3M-205P-VD-1 DC24V LF	Relay for Print Heater
SSR301	1000000164	RELAY,SSR G3M-205P-VD-1 DC24V LF	Relay for Dryer

3 Replacement of Main Parts

The necessary adjustments after the replacement of each part, and the referential time for each work are described as follows.

HEAD REPLACEMENT : 20min. (1 Head)

1. THERMISTER CHECK
2. HEAD ALIGNMENT
3. HEAD INFORMATION CLEAR
4. FLUSHING POSITION ADJUSTMENT
5. CROP-CUT ADJUSTMENT
6. PRINT / CUT POSITION ADJUSTMENT

Adj. Time : 65min

Total Time : 85min.

TOOL CARRIAGE REPLACEMENT : 20 min

1. LIMIT & CUT DOWN POSITION ADJUSTMENT
2. FLUSHING POSITION ADJUSTMENT
3. TOOL HEIGHT ADJUSTMENT
4. TOOL PRESSURE ADJUSTMENT
5. CROP MARK SENSOR ADJUSTMENT
6. CROP-CUT ADJUSTMENT
7. PRINT/CUT POSITION ADJUSTMENT

Adj. Time : 45min

Total Time : 65min.

Revised 1

CAP TOP REPLACEMENT : 20 min. (4pcs.)

1. FLUSHING POSITION ADJUSTMENT

Adj. Time : 5min

Total Time : 25min.

CARRIAGE MOTOR REPLACEMENT : 20 min

1. SERVO LOCK CHECK
2. AGING
It can be performed in the MOTOR MENU > AGING > SCAN.
3. MOTOR HOURS CLEAR

Adj. Time : 5min

Total Time : 25min.

FEED MOTOR REPLACEMENT : 30 min

1. SERVO LOCK CHECK
2. AGING
It can be performed in the MOTOR MENU > AGING > FEED.
3. GRIT ENCODER CHECK
4. MOTOR HOURS CLEAR

Adj. Time : 6min

Total Time : 36min.

GRIT ENCODER REPLACEMENT : 10 min

1. GRIT ENCODER CHECK

Adj. Time : 2min

Total Time : 12min.

PUMP REPLACEMENT : 20 min. (2 pcs.)

1. PUMP CHECK
2. PUMP TIMES CLEAR

Adj. Time : 2min

Total Time : 22min.

MAIN BOARD REPLACEMENT (In case that the parameters cannot be transferred by Peck.) : 35 min.

1. DIP SW SETTING
2. BATTERY INSTALLATION
3. FIRMWARE INSTALLATION
4. SYSTEM PARAMETER INITIALIZE
5. TIME AND DATE SETTING
Set the date and time in the [SERVICE MENU] > [SUB MENU] > [CLOCK]. *Set the [DATE] in order of the [Year/Month/Day].
6. IP ADDRESS SETTING
Start the machine with the Service Mode and set in the User Menu.
7. FIRMWARE VERSION CONFIRMATION OF NETWORK CONTROLLER
8. HEAD RANK SETTING
9. SERIAL NUMBER INPUT
10. INK TYPE SETTING
11. SENSOR CHECK
It can be performed in the SENSOR CHECK.
12. LIMIT POSITION & CUT DOWN POSITION INITIALIZE
13. FLUSHING POSITION ADJUSTMENT
14. LINEAR ENCODER SETUP
15. TOOL PRESSURE ADJUSTMENT
16. HEAD ALIGNMENT
Only Horizontal and Bidirectional Adjustments are required.
17. CALIBRATION
18. CROP MARK SENSOR ADJUSTMENT
19. CROP-CUT ADJUSTMENT
20. PRINT / CUT POSITION ADJUSTMENT

Adj. Time : 130min

Total Time : 165min.

Revised 4

MAIN BOARD REPLACEMENT (In case that the parameters can be transferred by Peck.) : 35 min.

1. DIP SW SETTING
2. BATTERY INSTALLATION
3. FIRMWARE INSTALLATION
4. SYSTEM PARAMETER INITIALIZE
5. IP ADDRESS SETTING
Start the machine with the Service Mode and set in the User Menu.
6. PUT PARAMETER
7. TIME AND DATE SETTING
Set the date and time in the [SERVICE MENU] > [SUB MENU] > [CLOCK]. *Set the [DATE] in order of the [Year/Month/Day].
8. FIRMWARE VERSION CONFIRMATION OF NETWORK CONTROLLER
9. SENSOR CHECK
It can be performed in the SENSOR CHECK.
10. CROP MARK SENSOR ADJUSTMENT
11. CROP-CUT ADJUSTMENT
Necessary when the voltage is adjusted in the CROP MARK SENSOR ADJUSTMENT.

Revised 4

Adj. Time : 40min
Total Time : 75min.

CUTTING CARRIAGE BOARD REPLACEMENT : 7min.

1. TOOL UP/DOWN CHECK
2. PINCH ROLLER SENSOR CHECK
3. CROP MARK SENSOR ADJUSTMENT
4. CROP-CUT ADJUSTMENT

Adj. Time : 23min
Total Time : 30min.

CARRIAGE BOARD REPLACEMENT : 10min.

1. HEAD UP/DOWN SENSOR CHECK (Only VP-540)
2. THERMISTER CHECK
3. LINEAR ENCODER SETUP

Adj. Time : 10min
Total Time : 20min.

PANEL BOARD REPLACEMENT : 7min.

1. LCD/LED//BUZ CHECK
It can be performed in the SUB MENU > LCD/LED/BUZ CHK.
2. KEY CHECK
It can be performed in the SUB MENU > KEY CHECK.

Adj. Time : 3min
Total Time : 10min.

SERVO BOARD REPLACEMENT : 18min.

1. I/S CHECK
It can be performed in the I/S MENU > I/S CHECK.
2. IC CHECK
It can be performed in the I/S MENU > CARTRIDGE > IC CHECK.
3. FAN CHECK
It can be performed in the SUB MENU > FAN CHECK > VACUUM FAN to check that there is a operation sound of the vacuum fans.
4. PUMP CHECK
It can be performed in the I/S MENU > PUMP CHECK > PUMP SUCTION to check the pumps work correctly.
5. SENSOR CHECK
It can be performed in the SENSOR CHECK.
6. HEATER CHECK
It can be performed in the HEATER MENU > HEATER CHECK.
7. GRIT ENCODER CHECK
It can be performed in the MOTOR MENU > G-ENC. CHECK.
8. AGING
It can be performed in the MOTOR MENU > AGING > BOTH.
9. TOOL UP/DOWN CHECK
It can be performed by [PAUSE] key in the CUTTING MENU > FORCE ADJUST.
10. TOOL PRESSURE ADJUSTMENT
11. CROP MARK SENSOR ADJUSTMENT
12. CROP-CUT ADJUSTMENT

Adj. Time : 40min
Total Time : 58min.

CARRIAGE BELT REPLACEMENT : 35min.

1. BELT TENSION ADJUSTMENT
2. BELT POSITION ADJUSTMENT
3. LIMIT & CUT DOWN POSITION INITIALIZE
4. FLUSHING POSITION ADJUSTMENT
5. CUTTING QUALITY CHECK

Adj. Time : 25min
Total Time : 60min.

Revised 1

ENCODER SCALE REPLACEMENT : 25min.

1. LINEAR ENCODER SETUP

Adj. Time : 5min
Total Time : 30min.

BATTERY REPLACEMENT : 7min.

1. TIME AND DATE SETTING

Adj. Time : 2min
Total Time : 9min.



Static electricity can harm some electronic devices. To prevent static damage, discharge static electricity from your body before you touch any of electronic devices. You can do so by touching an unpainted metal surface on the chassis.

You can also take the following steps to prevent damage from electrostatic discharge (ESD):

- When unpacking a static-sensitive device from its shipping carton, do not remove the device from the antistatic packing material until you are ready to install the device to the machine. Just before unwrapping the antistatic packaging, be sure to discharge static electricity from your body.
- When transporting a sensitive device, first place it in an antistatic container or packaging.
- Handle all sensitive devices in a static-safe area. If possible, use antistatic floor pads and workbench pads.

3-1 HEAD REPLACEMENT

Revised 1

VP-540/300 support the new head only. The parts number of the new head is as follows.

Parts No. : 1000002201

Parts name : ASSY,HEAD INKJET SOL XC-540

The number written on the back side of the Printhead Board is the way for identifying whether it is a new or current Head. "R4CJ520" is written on the new head.

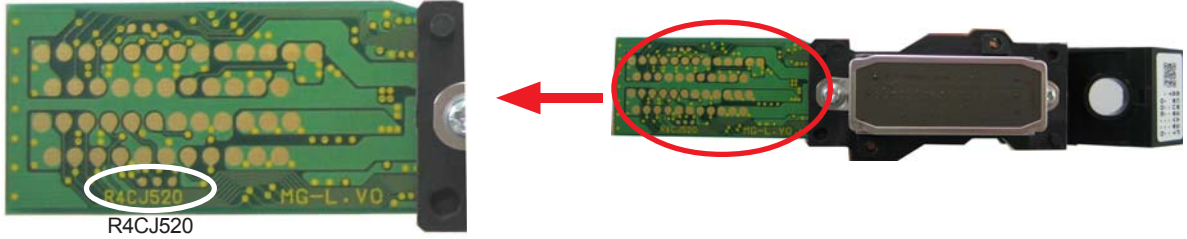

- 1 Turn on the sub power while pressing the left, right and down keys to enter the Service Mode.

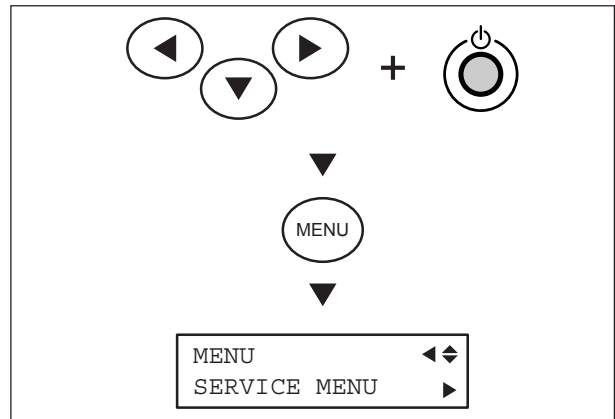

- 2 Select [SERVICE MENU] > [SUB MENU] > [PUMP UP], and remove ink by following the sequence.

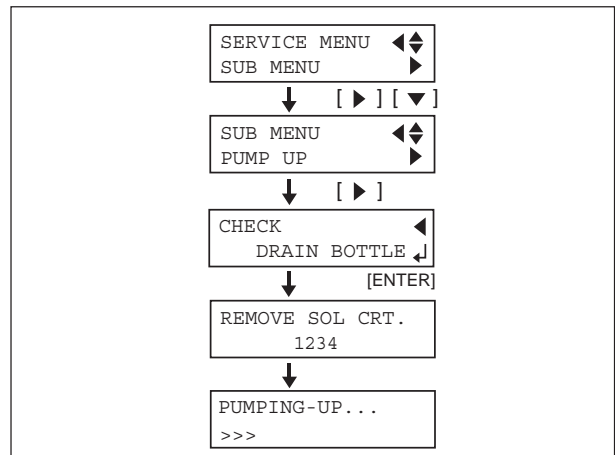

- 3 In [PRINT MENU] > [HEAD RANK] menu, select the head No. of the head that you are going to replace and input the Head Rank written on the new head. Input the Head Rank by selecting the digit with the left and right keys, and changing the parameters with the up and down keys. Press the [ENTER] key to save the settings.
* The head at the left end is [HEAD1], and [HEAD2] to [HEAD4] in order to the right.



Make sure to input the Head Rank before replacing the head, because the sticker which the head rank is written on will be hidden once the head is installed.

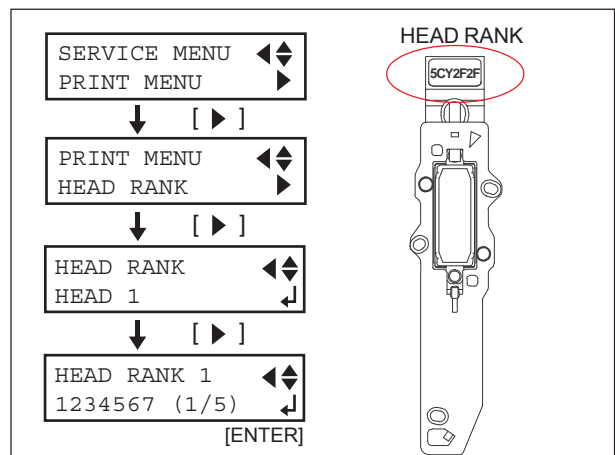

- 4** Turn off the sub power, and then turn off the main power.



Be sure to turn off the main power when replacing the head. The head or Main Board could break, otherwise. It is recommended to disconnect the AC code.

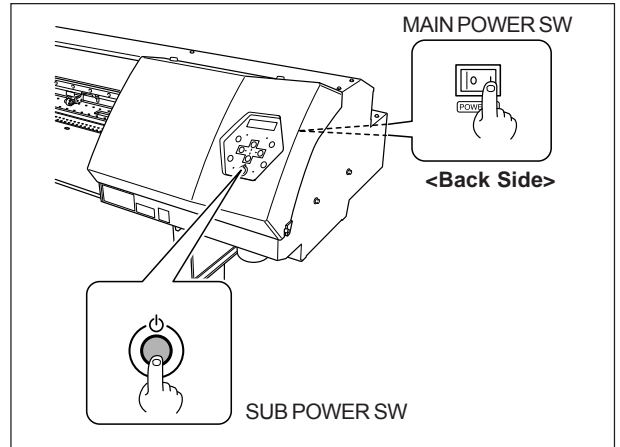

- 5** Remove the I/S Cover.

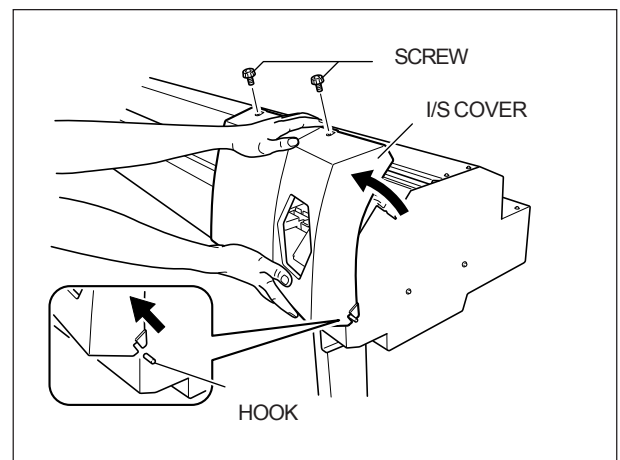

- 6** Remove the Right Top Cover and Carriage Cover.

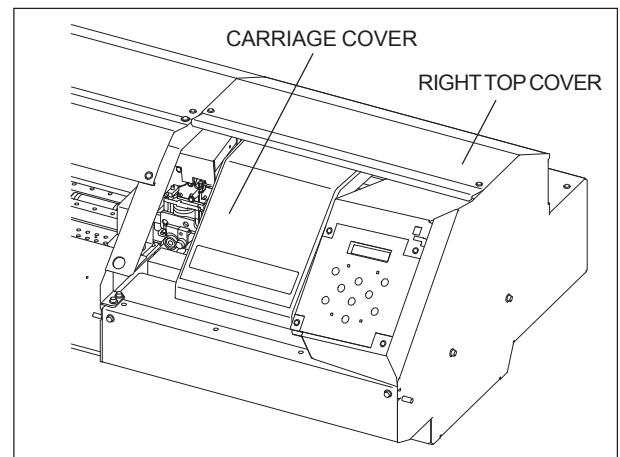

- 7** Remove the 2 screws to remove the Damper Plate.
 And remove the 2 Ink Dampers from the head which will be replaced.



Do not hold both sides of the Ink Damper tight. It could break.
 Be sure to remove and fix the Ink Damper with the Head Board Cover fixed. It prevents the ink from dropping on the Head Board.

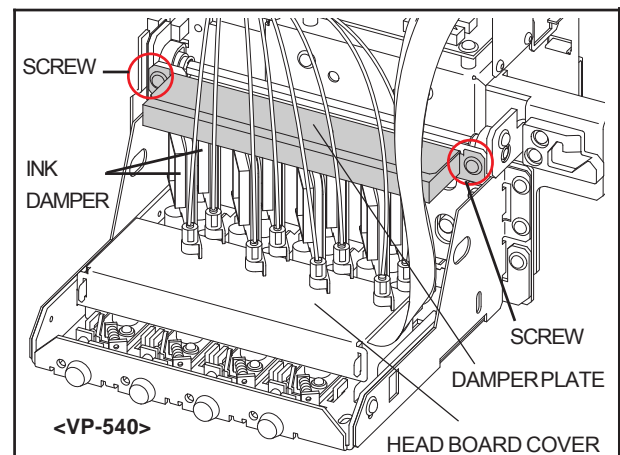

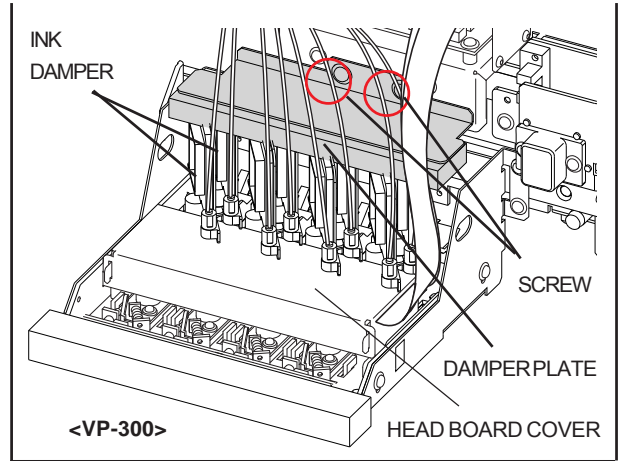

- 8** Remove the 2 screws fixing the Head Board Cover, and move it upward.



There is a tab on the left side of the Head Board Cover.

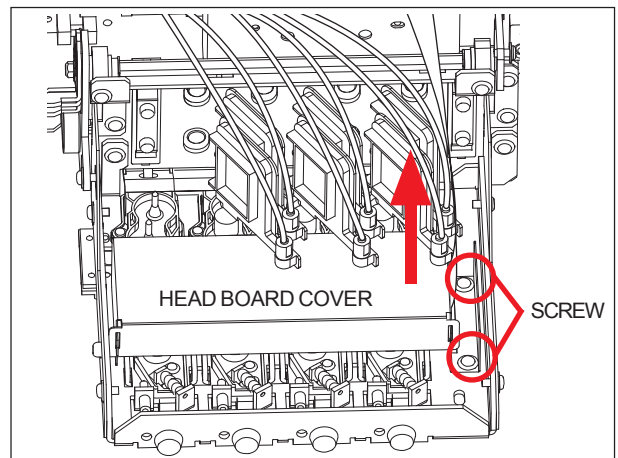
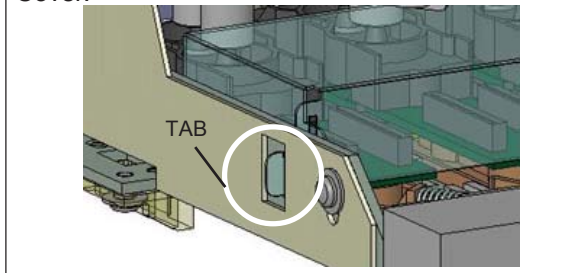

- 9** Disconnect the 2 flexible cables from the head.

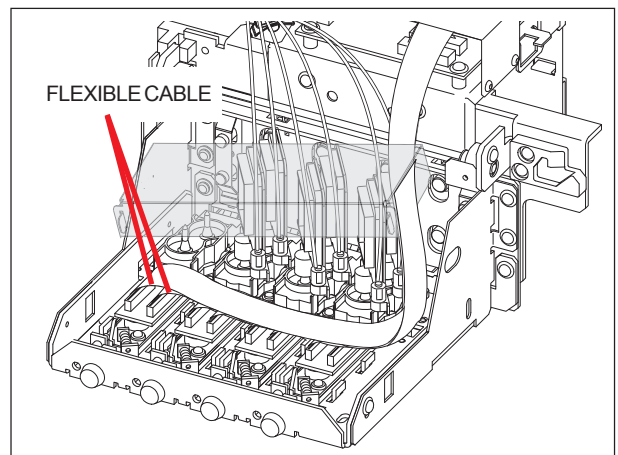

- 10** Remove the Spring, and remove the 3 screws fixing the head.

Then, pull the head towards the front and pull it up to remove it.

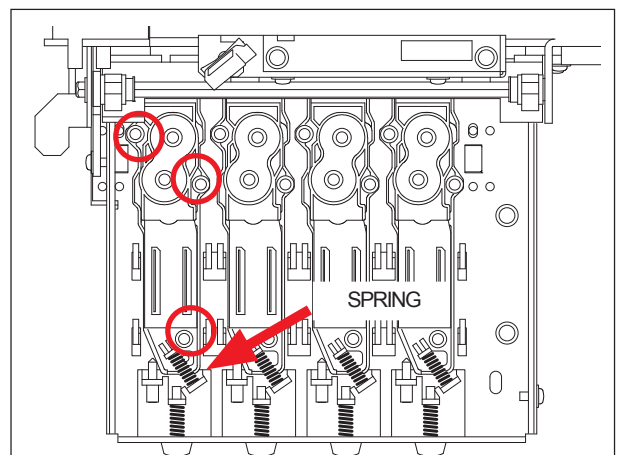

- 11** Remove the head from the adapter and fix the new head to the adapter.



Make sure to fix the head by pressing it to the bottom left corner of the adapter.
Use the 2kgf-cm torque driver (ST-056) to tighten up the screws.

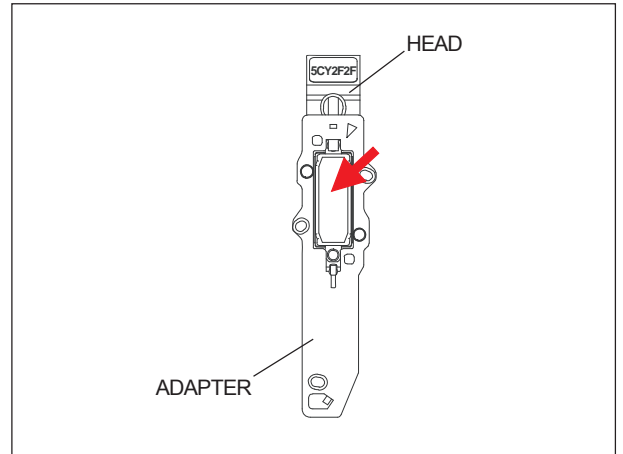

- 12** Install the head to the Head Carriage and fix the 3 screws temporarily. Then, fix the spring and tighten up the 3 screws in order as shown in the figure.



Use the 2kgf-cm torque driver (ST-056) to tighten up the screws.

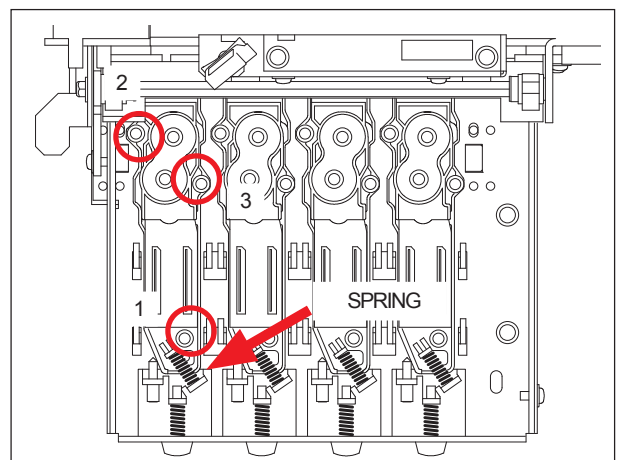

- 13** Connect the 2 flexible cables to the Head Board.



Do not connect the cables to the wrong connector.

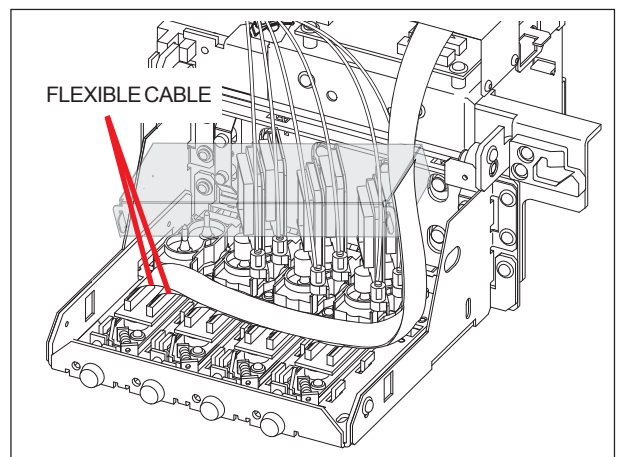

- 14** Fix the Head Board Cover.



When fixing the Head Board Cover, hook the tab to the Carriage Base.

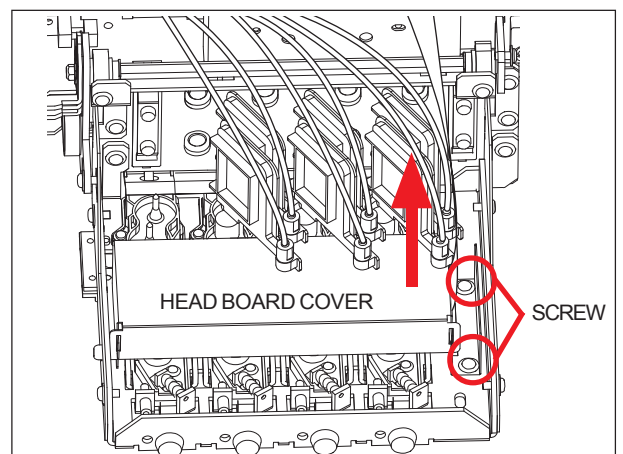
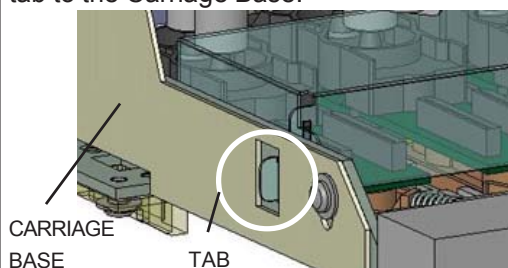

15 Fix the 2 new Ink Dampers to the head.



Make sure to replace the Dampers when replacing the head.



Do not hold both sides of the Ink Damper tight. It could break.

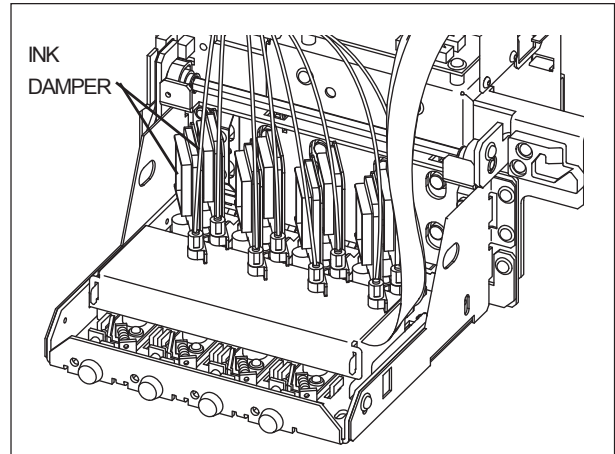

16 Fix the Damper Plate.



Make sure not to press it to the Dampers. Dampers could break.

* Fix the screws at the lower end of the long screw hole.

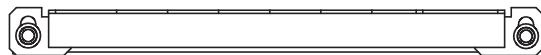

< VP-540 >

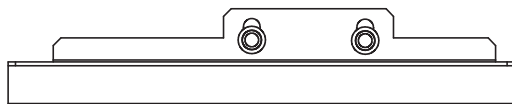

< VP-300 >

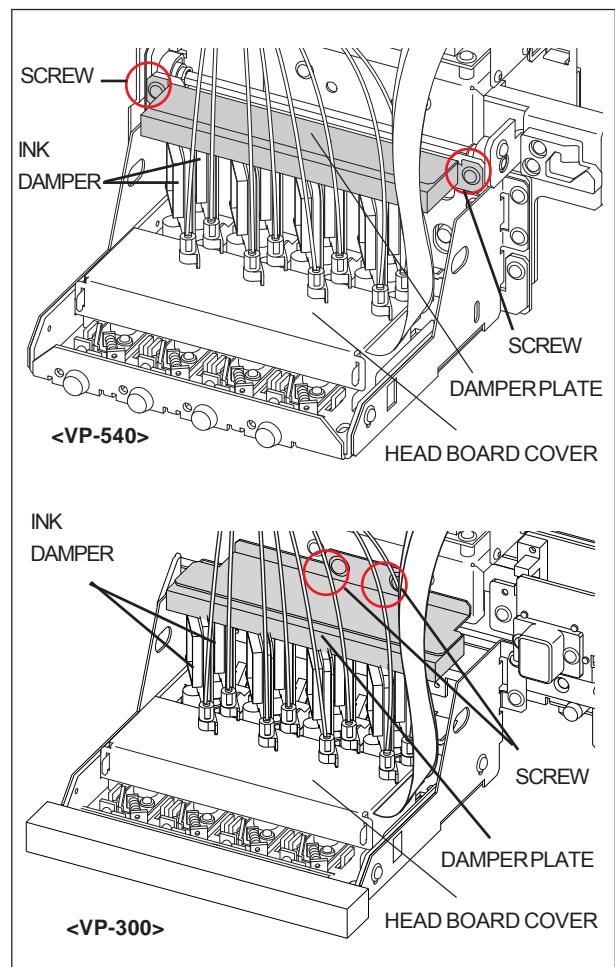

17 Turn on the main power, and then turn on the sub power while pressing the left, right and down keys to enter the Service Mode.

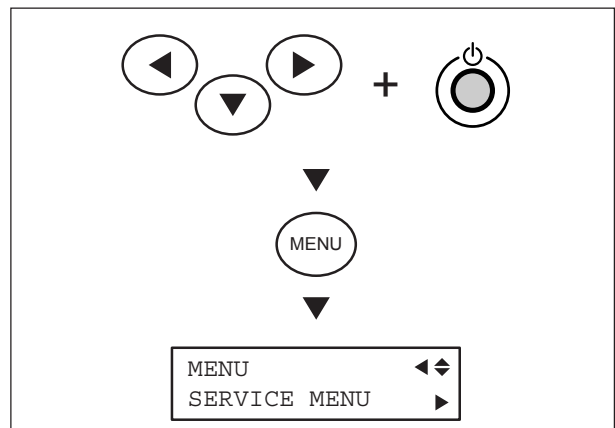

18 Select [SERVICE MENU] > [SUB MENU] > [HEAD REPLACE], and perform Head Cleaning and filling ink by following the sequences.

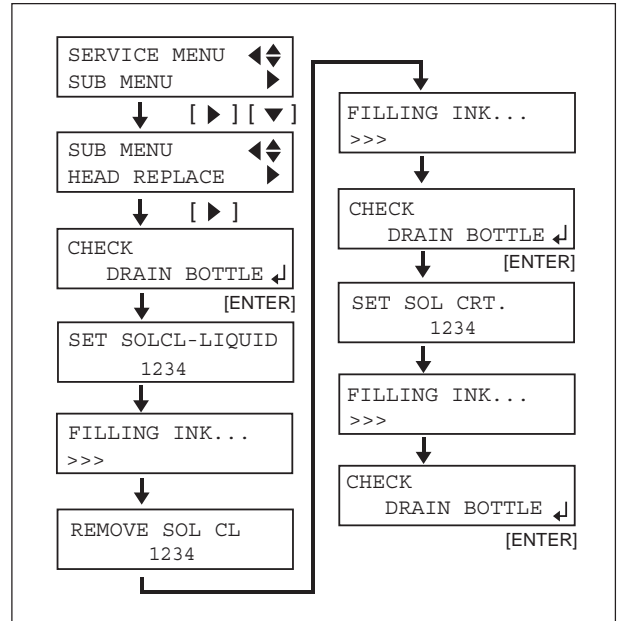

* If you dispose of the drained ink, the drain counter needs to be reset. Select [SUB MENU] > [MAINTENANCE] > [RESET DRAIN COUNTER] in the User's menu, and press the [ENTER] key.

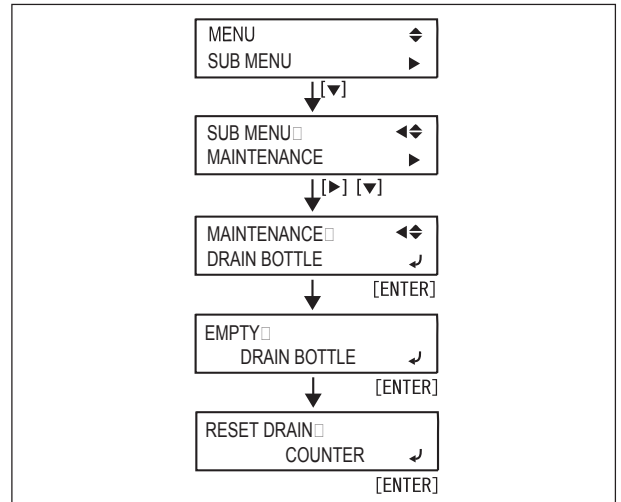

19 Enter the Service Mode and perform the following adjustments.

1. THERMISTER CHECK
2. [4-4 HEAD ALIGNMENT]
3. [4-7 FLUSHING POSITION ADJUSTMENT]
4. [4-9 CROP-CUT ADJUSTMENT]
5. [4-10 PRINT / CUT POSITION ADJUSTMENT]

< HOW TO CLEAR THE HEAD INFORMATION >

After THERMISTER CHECK and HEAD ALIGNMENT, clear the head information from the [SERVICE MENU] > [HISTORY MENU] > [HEAD GROUP]. Select the head you replaced and press the [ENTER] key.

* The head at the left end is [HEAD1], and [HEAD2] to [HEAD4] in order to the right.

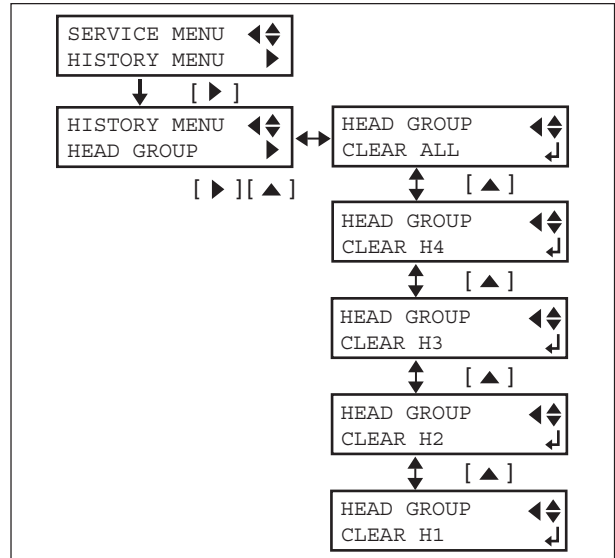

< NOTE FOR FIXING THE CARRIAGE COVER >

When fixing the Carriage Cover, fix the screws on top after fixing the screws on the both sides temporarily.

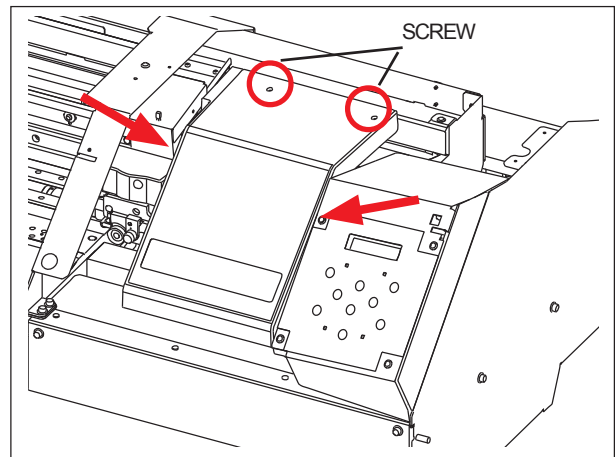

3-2 WIPER REPLACEMENT

- 1 Select [SUB MENU] > [MAINTENANCE] > [REPLACE WIPER] in the User's Menu, and press the [ENTER] key.

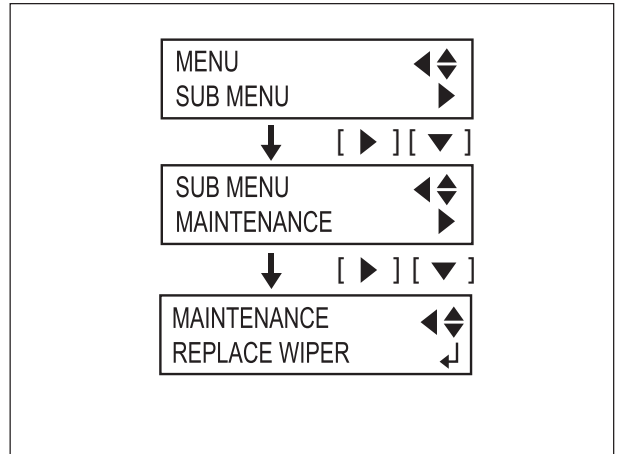

- 2 The Head Carriage moves to a location permitting wiper replacement, and then the message shown in the figure appears.
Remove the I/S Cover.

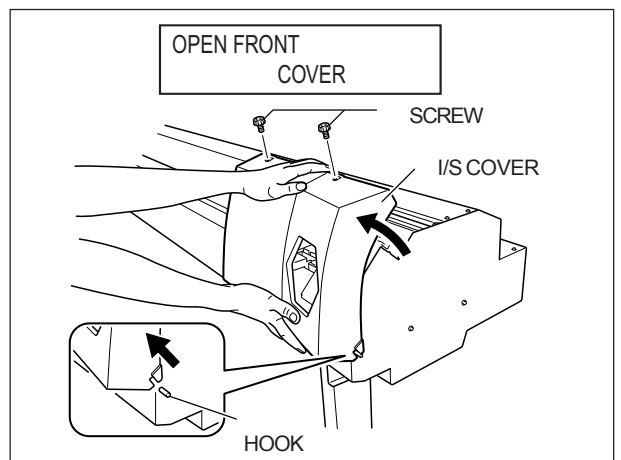

- 3 The message shown in the figure appears.

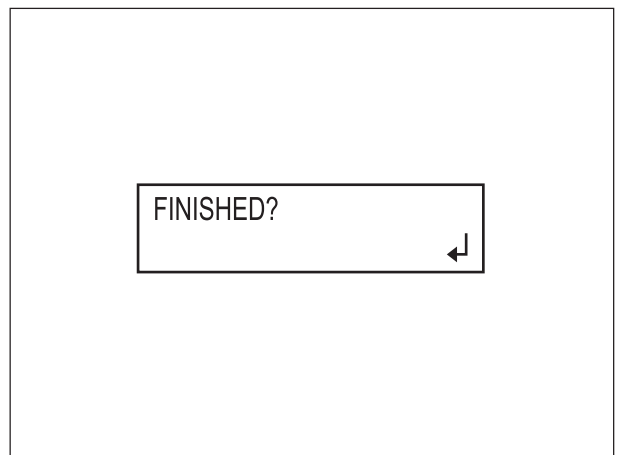

- 4 Using the tweezers, grasp the bottom portion of the wiper and unhook it.



Clean the Wiper Carriage and Scraper using the cleaning stick if they need to be cleaned.

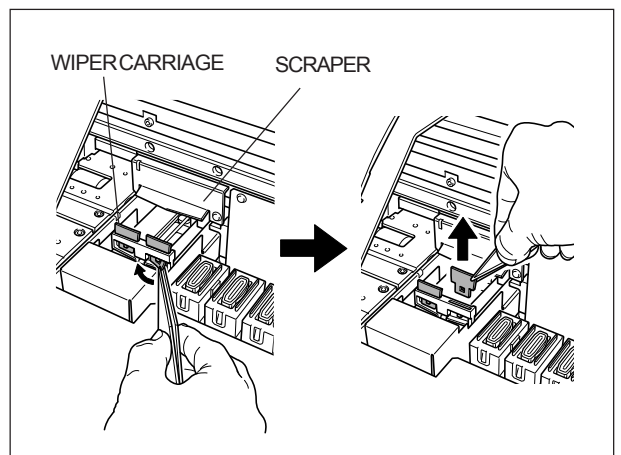

5 Remove the wiper and install the new one.



Make sure to fix the Wiper so that the rubber side faces the front.

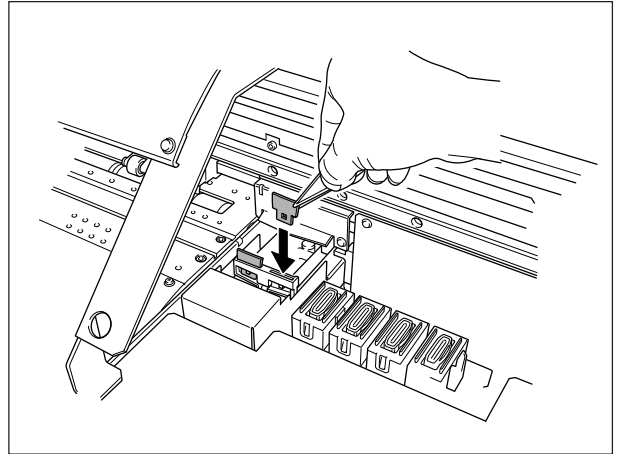

6 Use the tweezers to press the area shown in the figure and engage the wiper on the hook.



Make sure to engage it on the hook. If the wiper is not hooked, it may fall off during use.

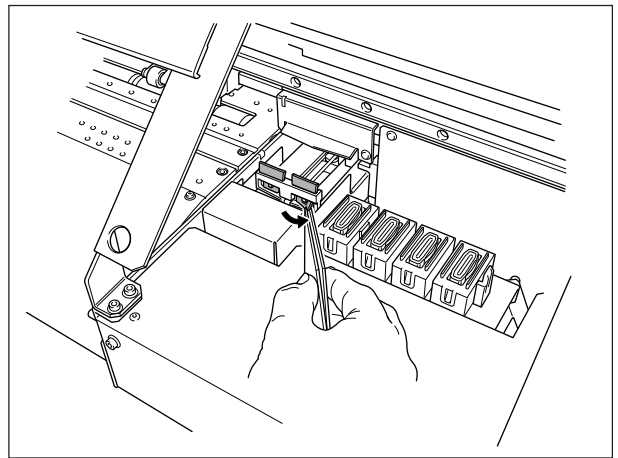

7 Fix the I/S Cover, and press the [ENTER] key.
The Head Carriage moves back to the standby position and the Head Cleaning starts automatically. When the Head Cleaning finishes, the screen shown in the figure appears.

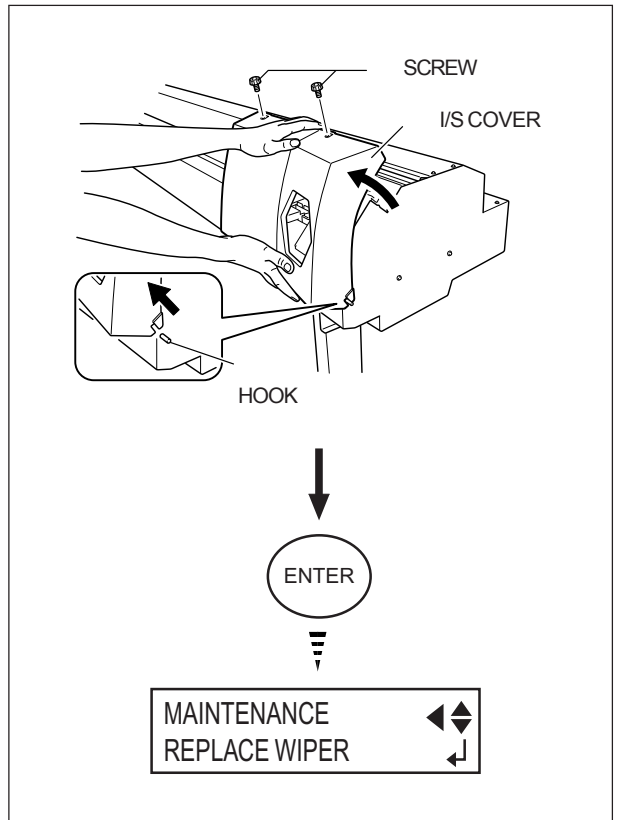

3-3 CAP TOP REPLACEMENT

- 1 Remove the I/S Cover.

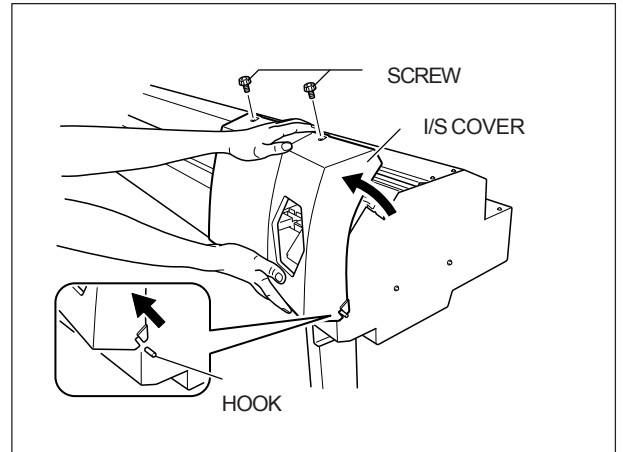

- 2 Move the Head Carriage slowly leftwards to the position where it is not above the Capping Unit.

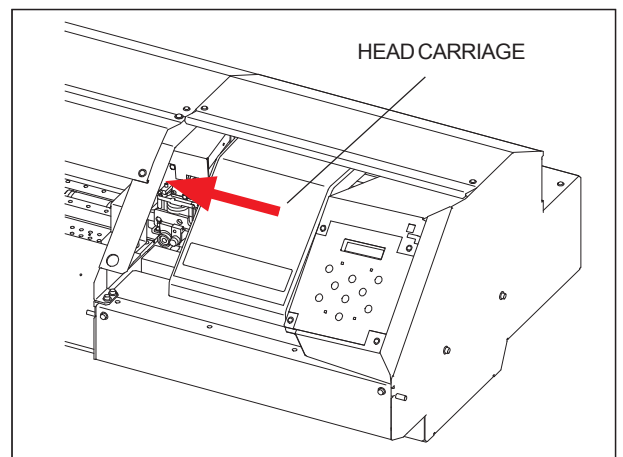

- 3 Remove the Pump Cover.

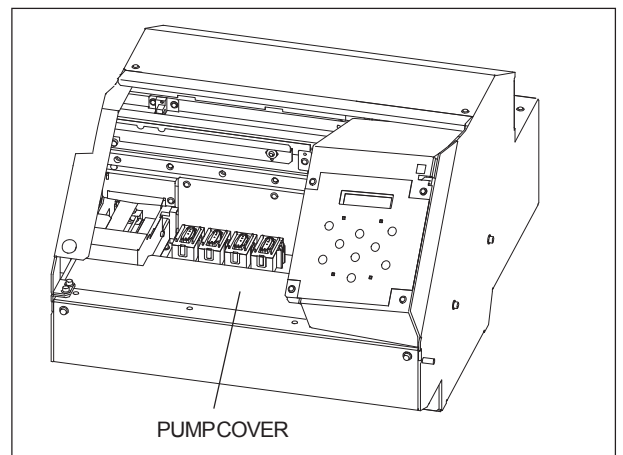

- 4 Disconnect the tube of the Cap Top from the tube of the Pump.
Save the Y tube joint to use later for connecting the tube of the new Cap Top.

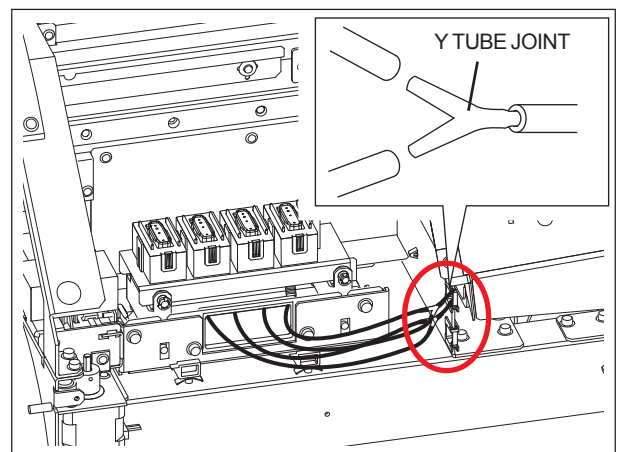

- 5** Unhook the Cap Frame while holding it with the other hand, and remove it.



Make sure to hold the Cap Frame. There is a spring under the Cap Top. The Cap Top jumps out unless you hold the Cap Frame when removing it.

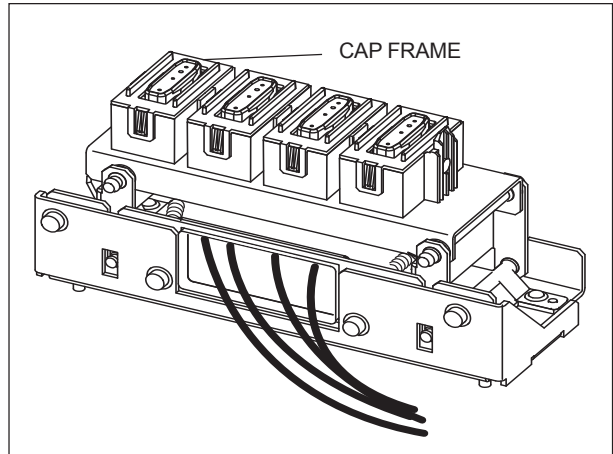

- 6** Remove the Cap Top together with the tube.

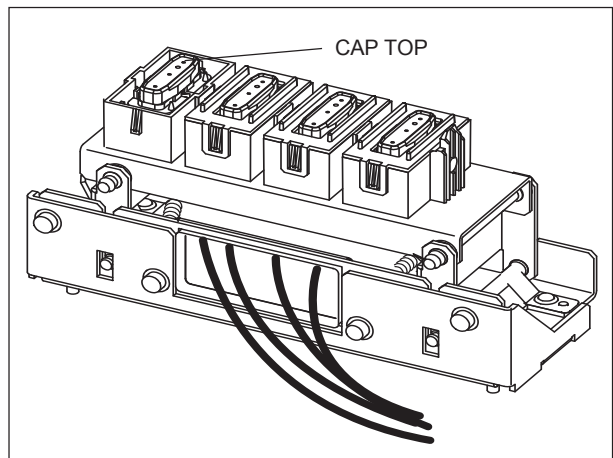

- 7** Fix the new Cap Top. Make sure to fix it so that the tube side faces the front.



Note the following contents.

1. Do not touch the tip of rubber on the Cap Top.
2. The spring is properly fixed under the Cap Top.
3. Do not bend the tubes.

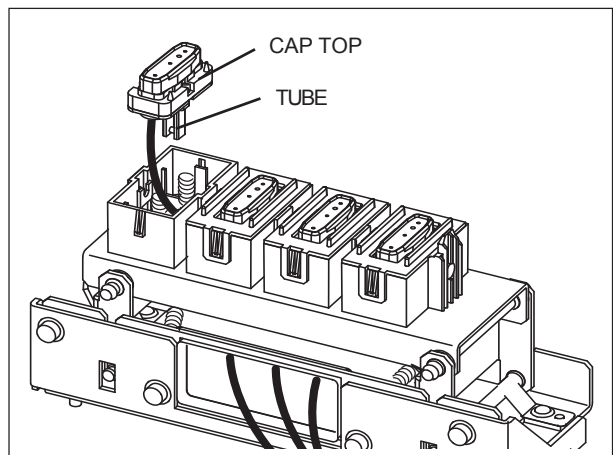

- 8** Fix the Cap Frame.

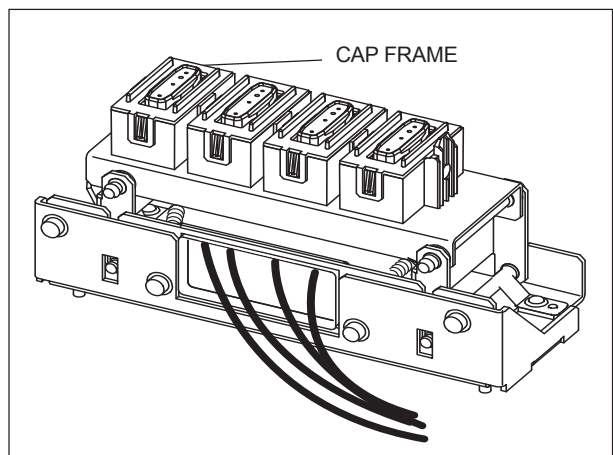

- 9** Connect the tube of the Cap Top to the tube of the Pump using the Y tube joint.

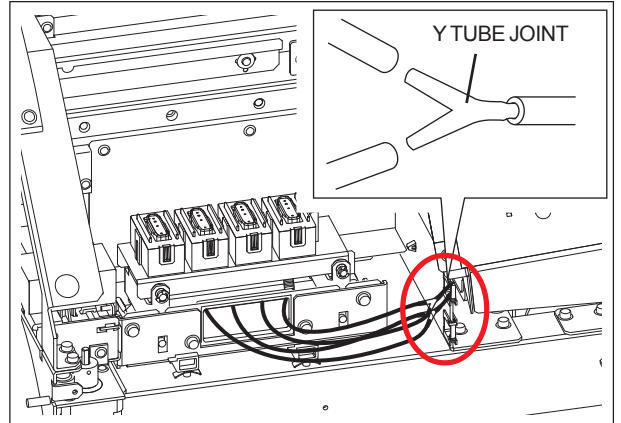

- 10** Fix the Pump Cover.

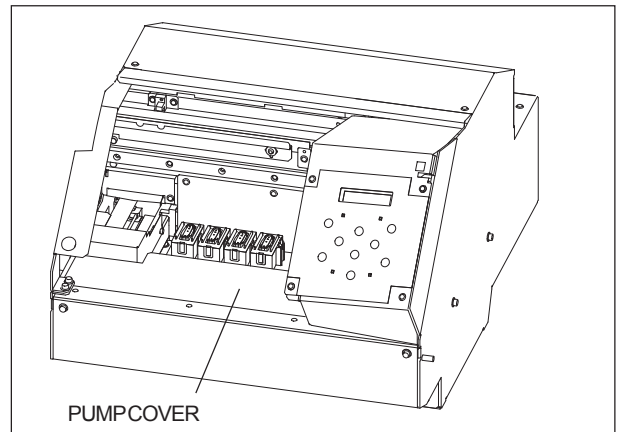

- 11** Move the Head Carriage by hand to the lock position.

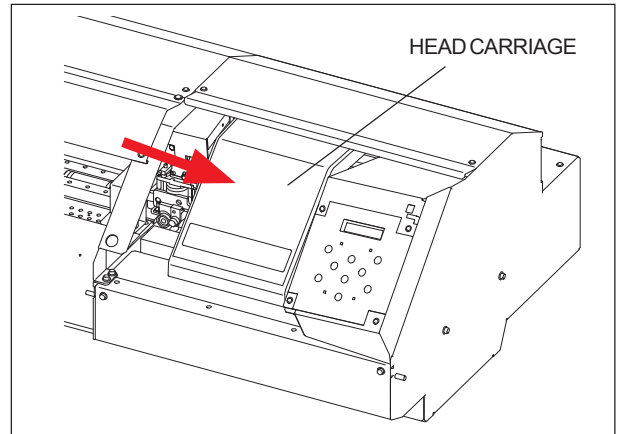

- 12** Fix the I/S Cover.

Perform the following adjustment.
1. [4-7 FLUSHING POSITION ADJUSTMENT]

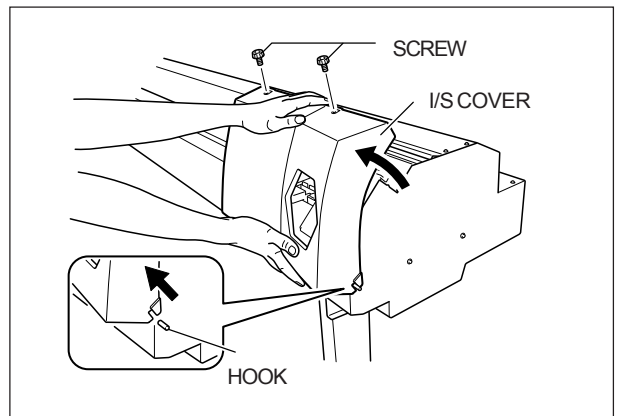

3-4 TOOL CARRIAGE REPLACEMENT

1 Remove the following covers.

- I/S Cover
- Maintenance Cover
- Left Side Cover
- Front Cover
- Top Cover

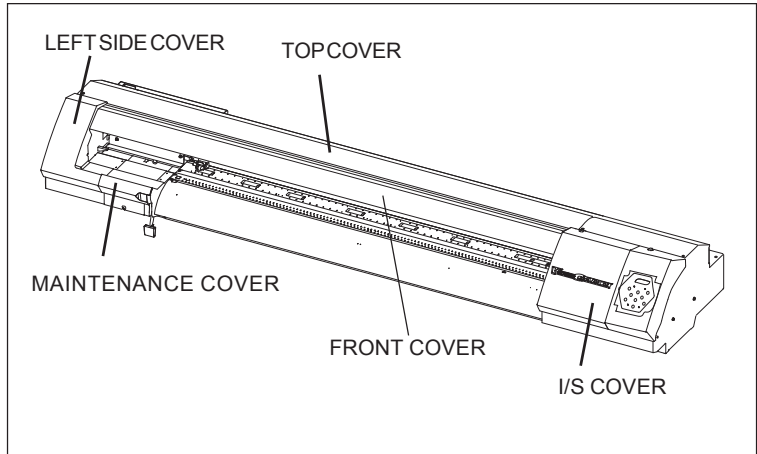

2 Separate the Tool Carriage from the Head Carriage.

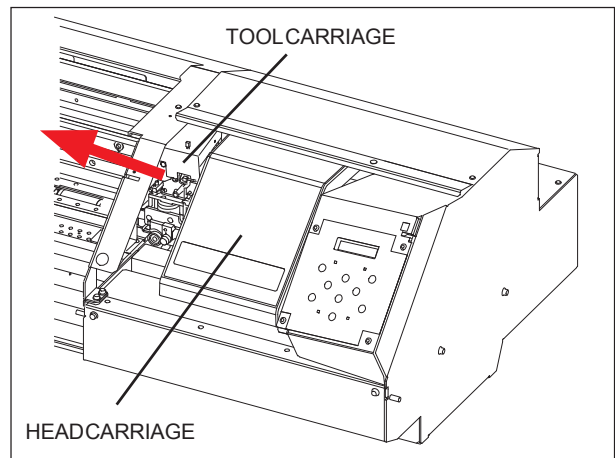

3 Remove the Tool Carriage Cover.

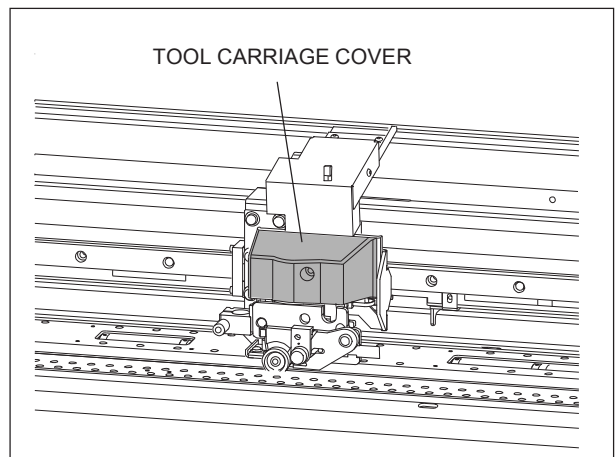

4 Remove the 4 rivets as shown in the figure to remove the Tool Carriage Board Cover.

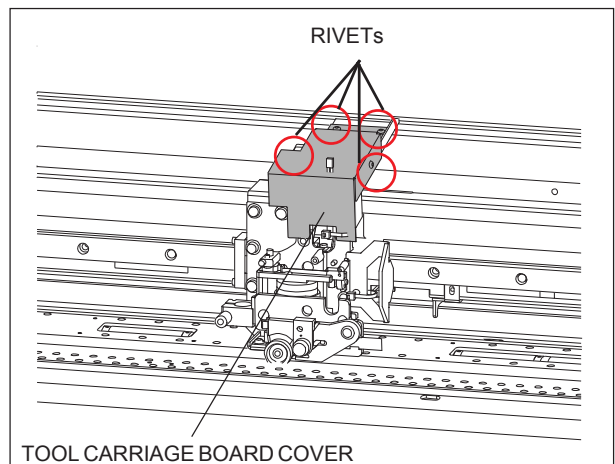

- 5** Disconnect the Crop Mark Sensor, Pinch Roller Sensor and Solenoid wirings.

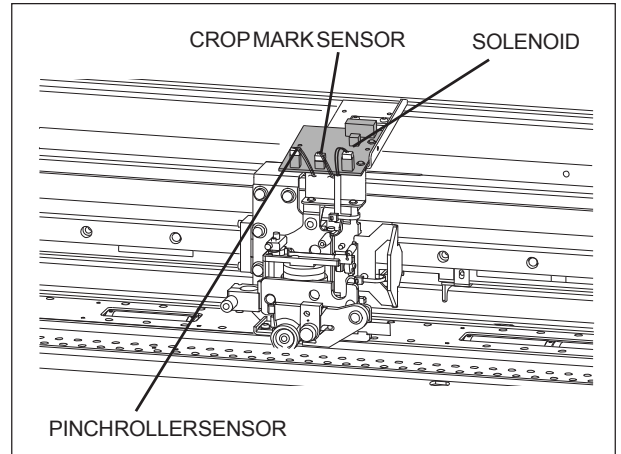

- 6** Remove the 2 screws fixing the Tool Carriage Board.

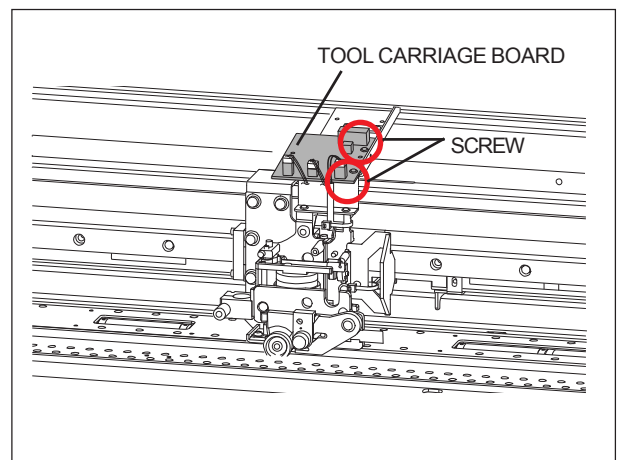

- 7** Remove the 2 screws to remove the Tool Carriage Board Stay from the Tool Carriage Assy.

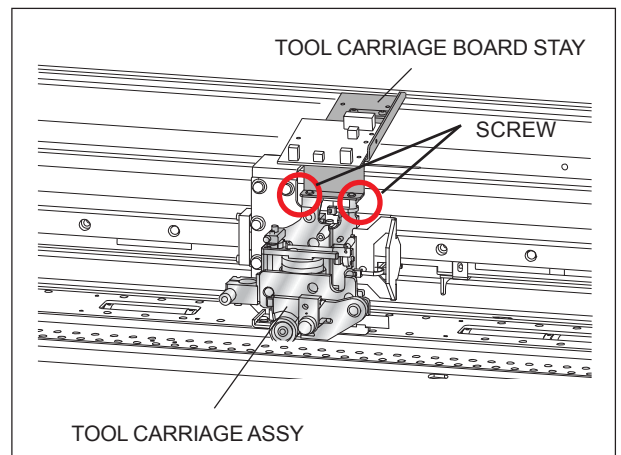

- 8** Remove the 2 screws as shown in the figure to remove the Tool Carriage Assy.

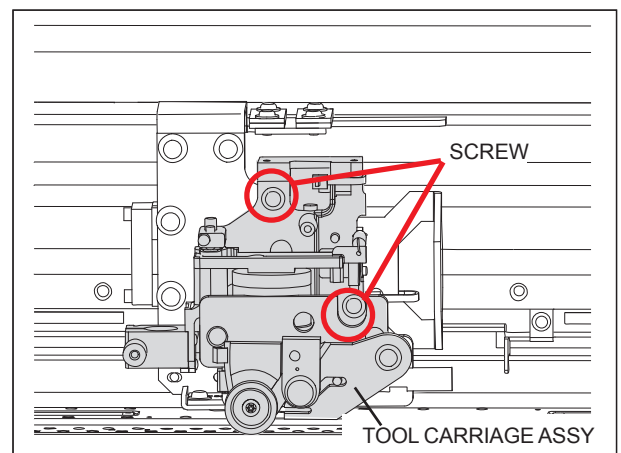

- 9** Remove the Auto Sheet Cutter together with the plate from Tool Carriage and fix the Auto Sheet Cutter to the new Tool Carriage.

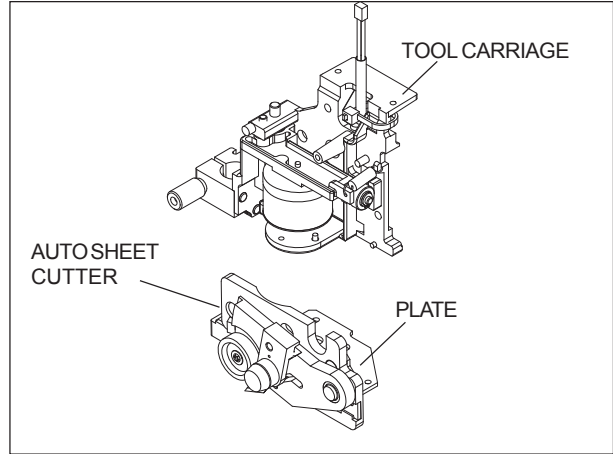

- 10** Fix the new Tool Carriage with the 2 screws as shown in the figure while holding it upwards.

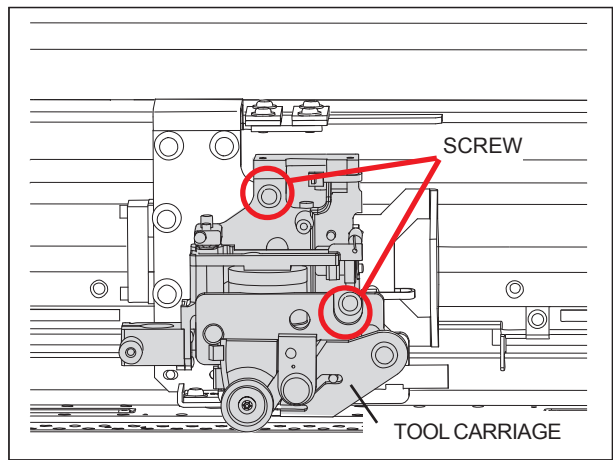

- 11** Fix the Tool Carriage Assy to the Tool Carriage Board Stay with the 2 screws as shown in the figure.

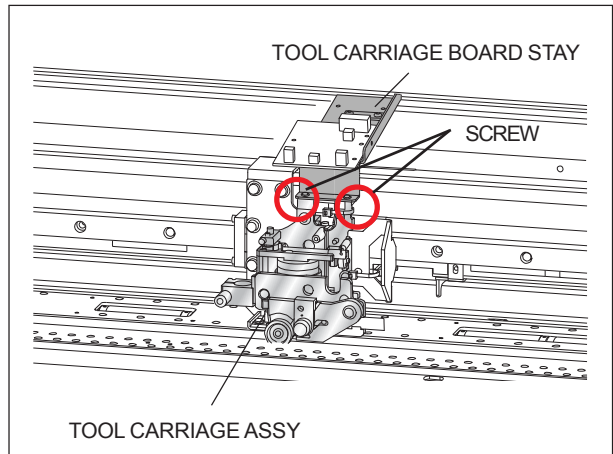

- 12** Fix the Tool Carriage Board with the 2 screws as shown in the figure.

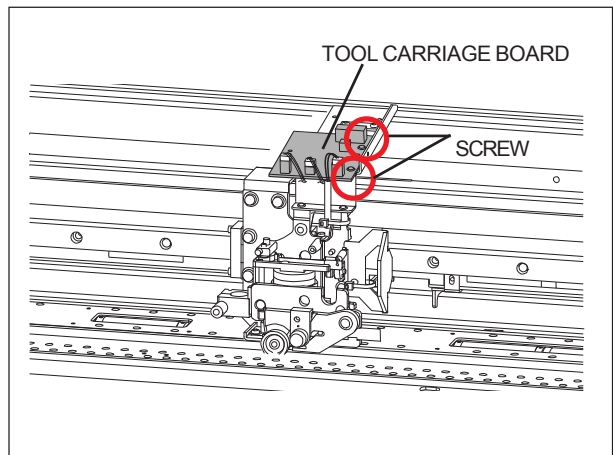

- 13** Connect the Crop Mark Sensor, Pinch Roller Sensor and Solenoid wirings.

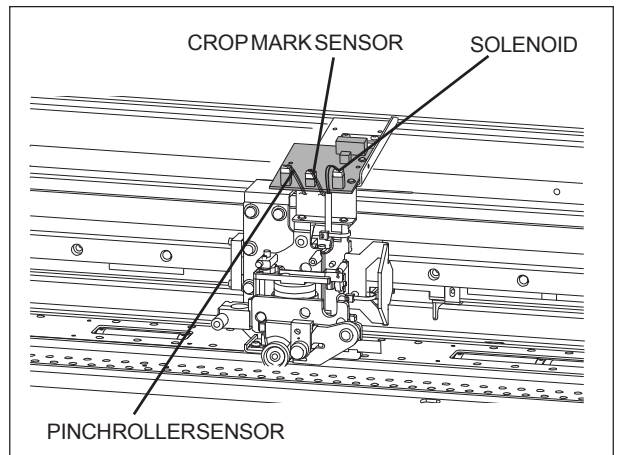

- 14** Perform the following adjustments and settings.

Revised 1

1. [4-5 LIMIT POSITION & CUT DOWN POSITION INITIALIZE]
2. [4-7 FLUSHING POSITION ADJUSTMENT]
3. [4-12 TOOL HEIGHT ADJUSTMENT]
4. [4-13 TOOL PRESSURE ADJUSTMENT]
5. [4-8 CROP MARK SENSOR ADJUSTMENT]
6. [4-9 CROP-CUT ADJUSTMENT]
7. [4-10 PRINT / CUT POSITION ADJUSTMENT]

3-5 CARRIAGE MOTOR REPLACEMENT

1 Turn off the sub power, and then turn off the main power.

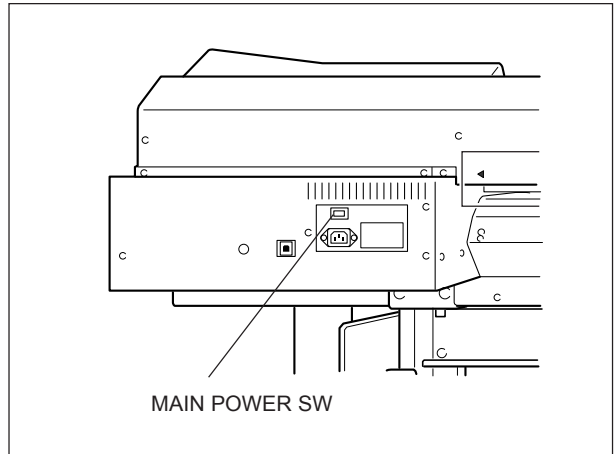

2 Remove the following covers.

- I/S Cover
- Right Top Cover
- Panel Cover
- Chassis Cover

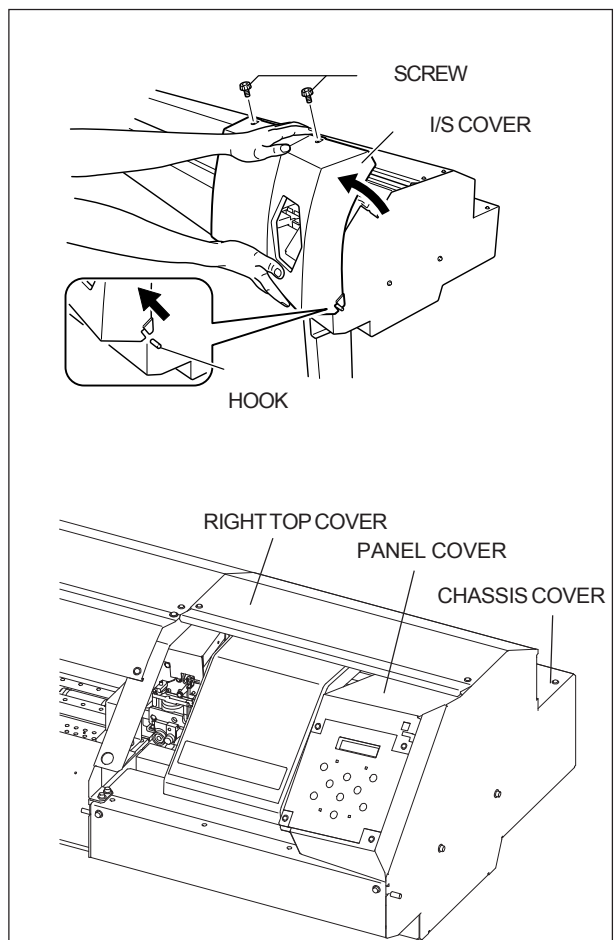

When removing the Panel Cover, remove the sensor on the back side of the Panel Cover and flexible cable on the Panel Board.

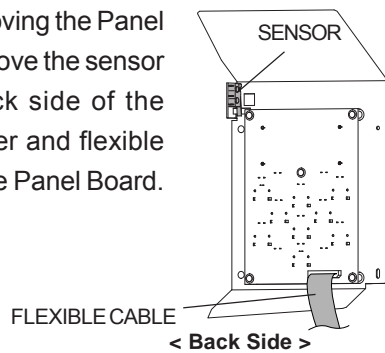

3 Disconnect the connector of the Motor Cable.

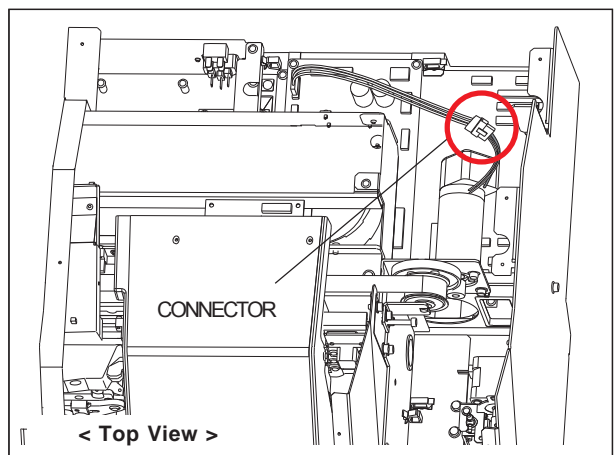

4 Remove the spring on the Flange.

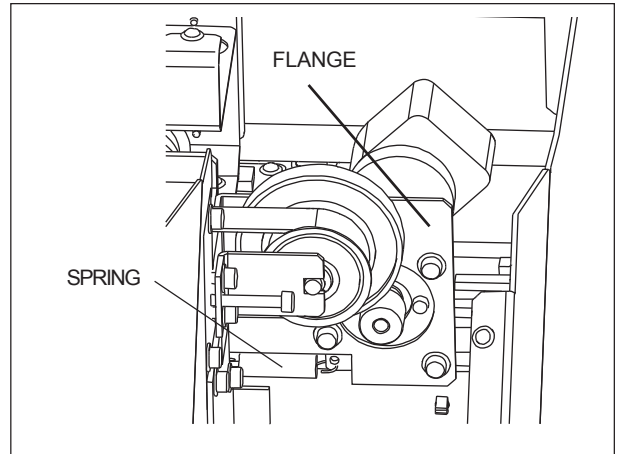

5 Remove the 3 screws fixing the Flange, and remove the motor together with the Flange.

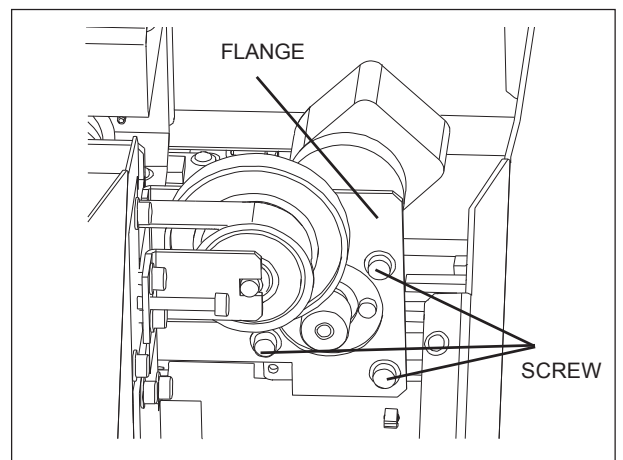

6 Remove the 4 screws as shown in the figure to remove the motor from the Flange.
And fix the new motor to the Flange.



Be careful with the fixing direction of the Flange.

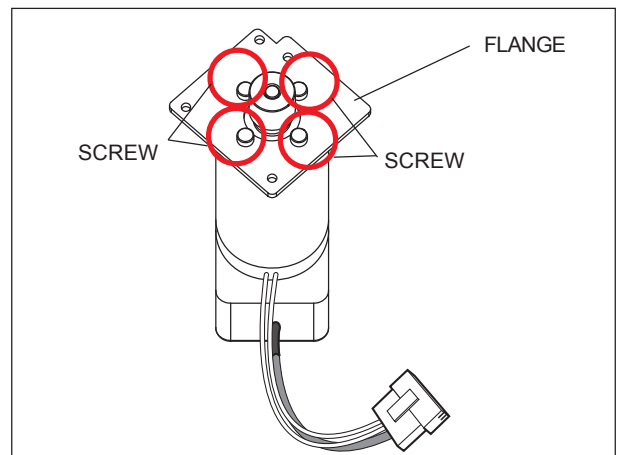

7 Fix the Flange with the 3 screws temporarily.

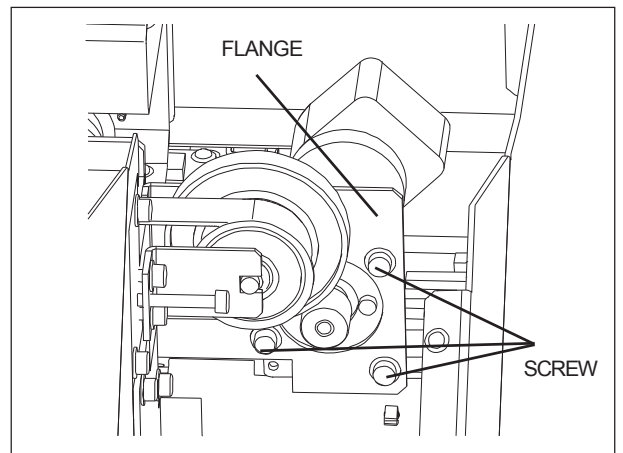

8 Fix the spring.

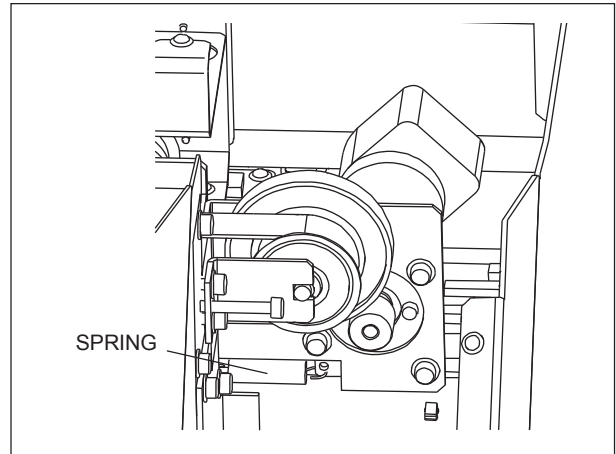

Revised 1

9 Check the gears mesh without backlash in the following procedure.

1) Unlock the Head Carriage.

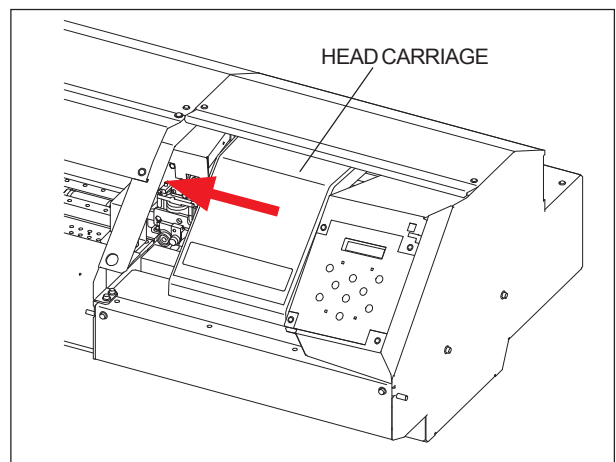

2) Turn the Drive Gear by hand and check there is no backlash all the way around.

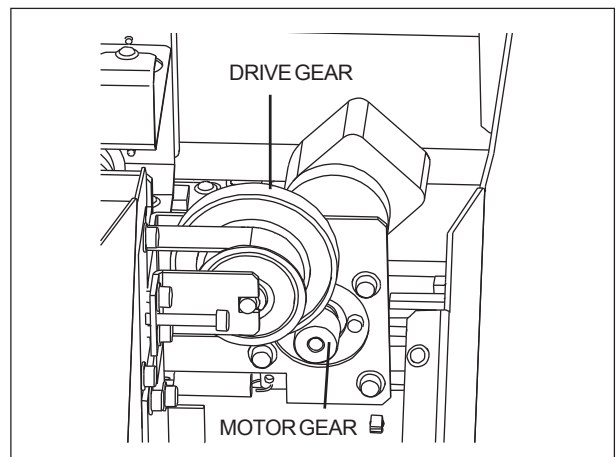

3) Move the Head Carriage by hand to the lock position.

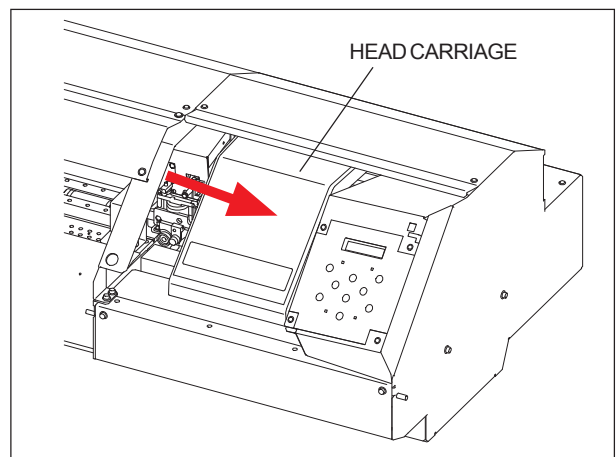

- 10** Tighten up the 3 screws to fix the Flange in the order shown in the figure.



Apply a proper quantity of grease (FLOIL G902) between gears.

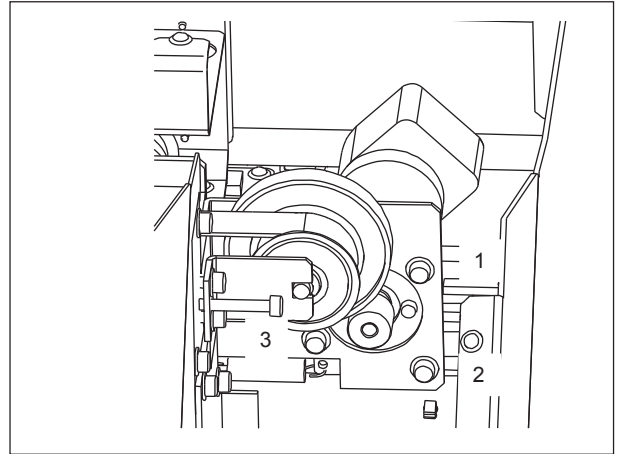

- 11** Connect the connector of the Motor Cable.

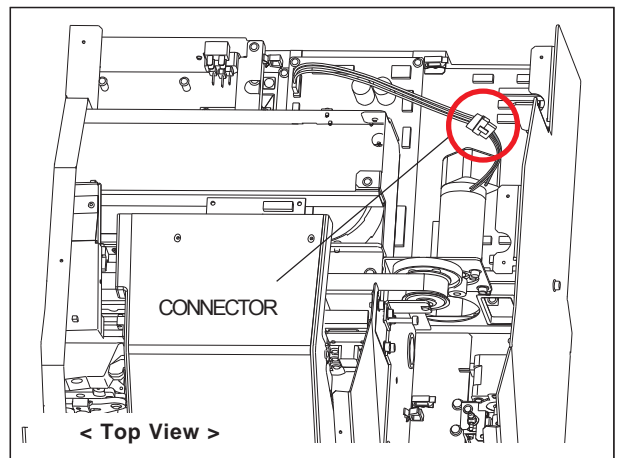

- 12** Fix the Chassis Cover, Right Top Cover and Panel Cover.



When fixing the Panel Cover, fix the sensor on the back side of the Panel Cover and connect the flexible cable to the Panel Board.

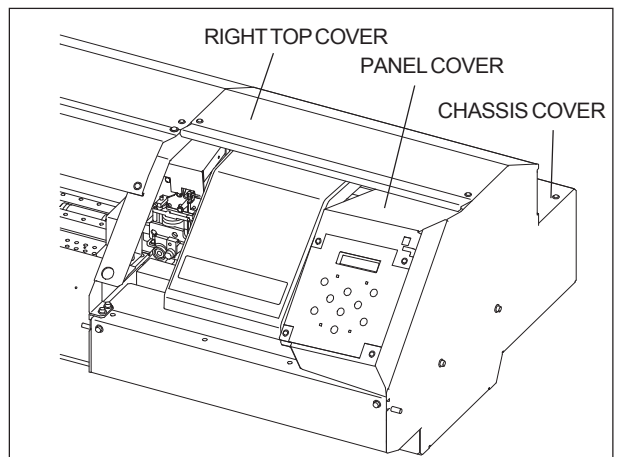
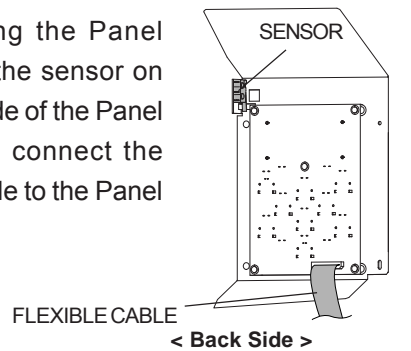

- 13** Perform the SERVO LOCK CHECK.
After turning on the main power, turn on the sub power while pressing the left, right and down keys to enter the Service Mode.

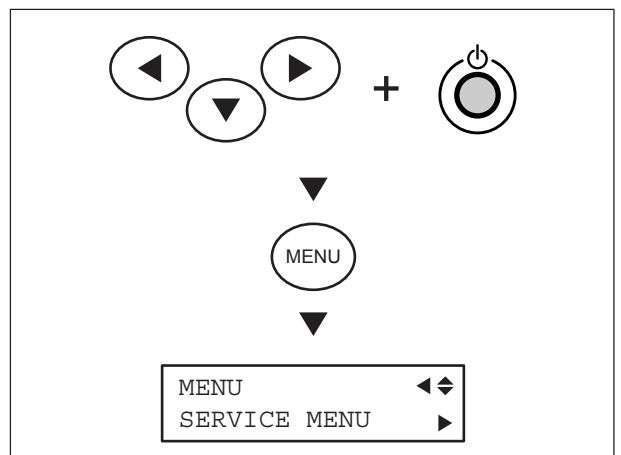

- 14** In [MOTOR MENU] > [SERVO LOCK] menu, select [S]. Move the Head Carriage left and right by hand and make sure the value on the LCD changes depending on the head position.

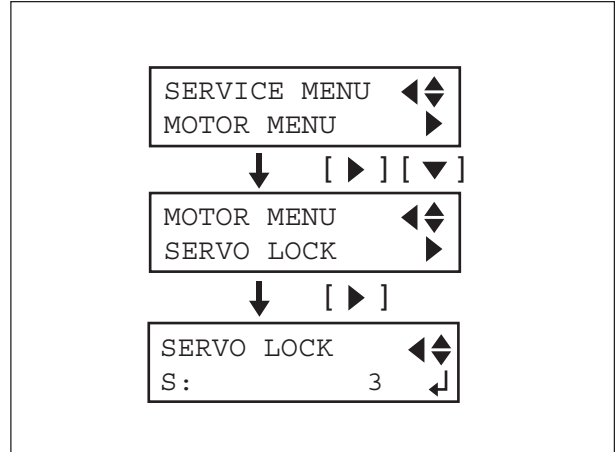

- 15** Press the [ENTER] key to excite the motor. Check the Head Carriage can not be moved easily by hand and the value on the LCD doesn't change.

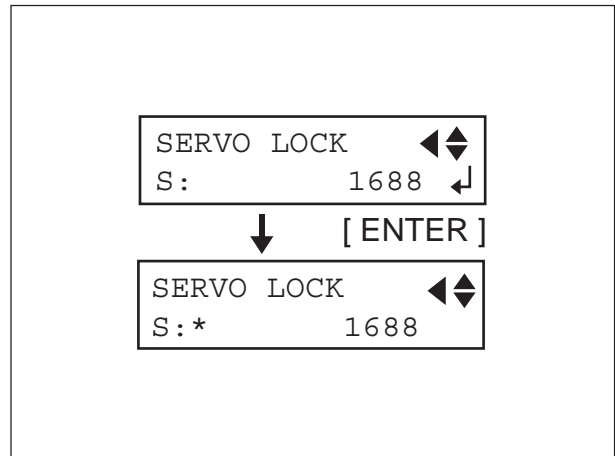

- 16** Perform the AGING. Go back to the [MOTOR MENU], and select [AGING] > [SCAN] and press the [ENTER] key. Make sure the machine performs AGING and then, finish it by pressing [ENTER] key.



Do not load any media when performing [AGING].

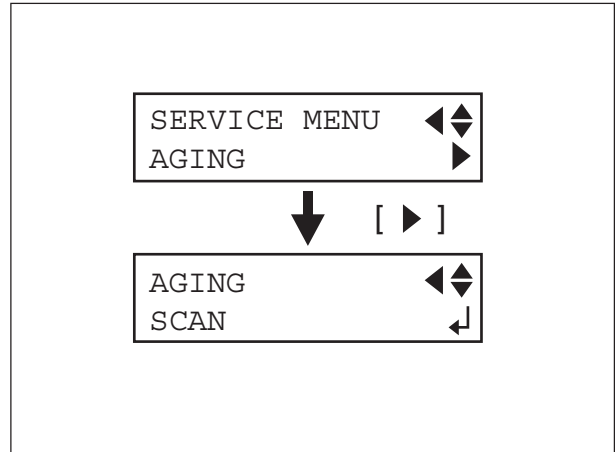

- 17** Clear the motor working hours. Go back to the Service Menu, and select [HISTORY MENU] > [MOTOR GROUP] > [MOTOR HOURS S] > [CLEAR] and press the [ENTER] key. The motor working hours will be reset to 0.

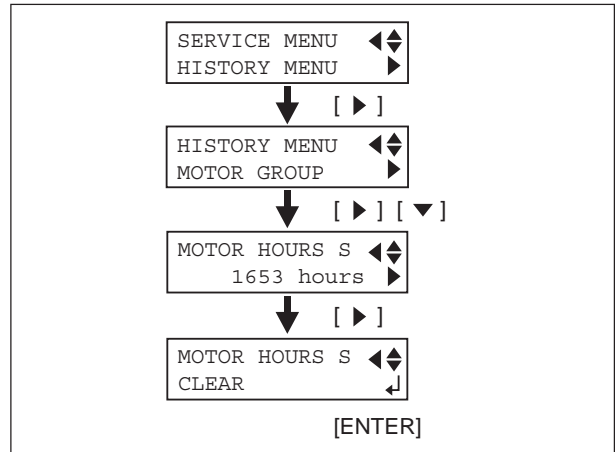

3-6 FEED MOTOR REPLACEMENT

1 Turn off the sub power, and then turn off the main power.

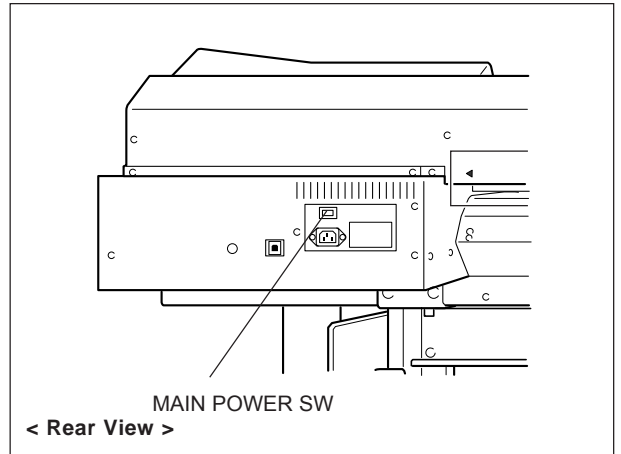

2 Remove the following covers.

- Maintenance Cover
- Left Side Cover
- Left Cover
- Ink Cartridge Cover

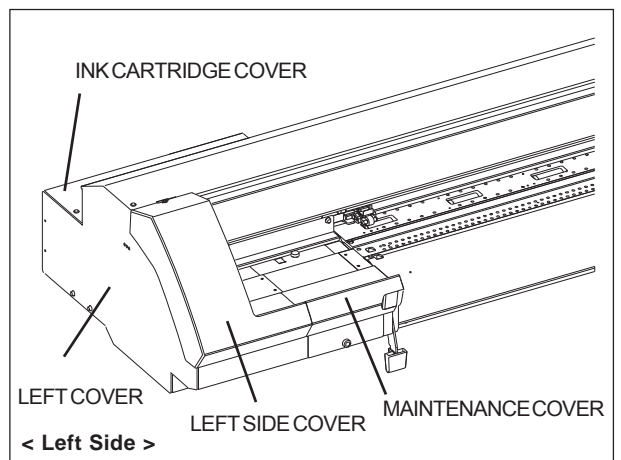

3 Disconnect the connector of the sensor cable from the Feed Motor Board.

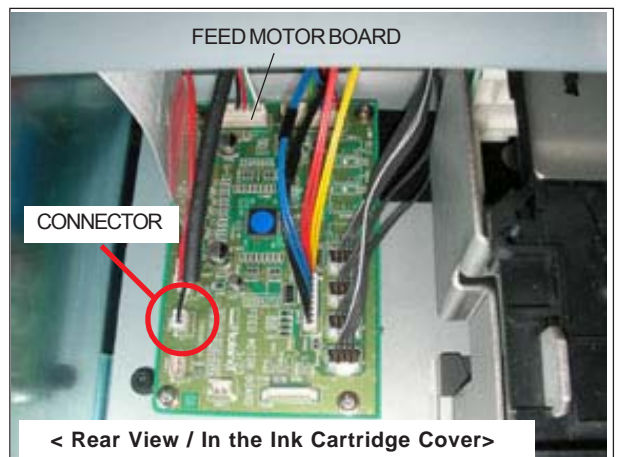

4 Remove the Cutter Frame.



When removing the Cutter Frame, remove the Sensor Cable on the back side from the Clamp.

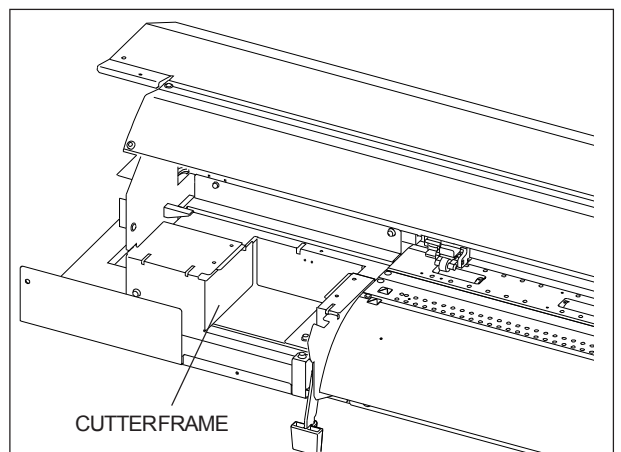
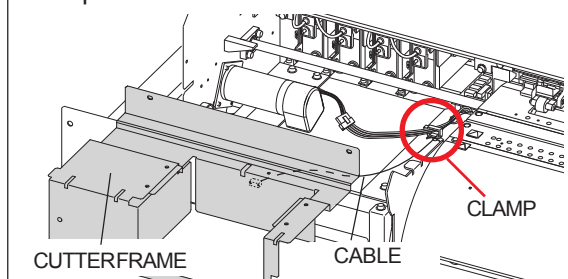

5 Remove the connector of the Motor Cable.

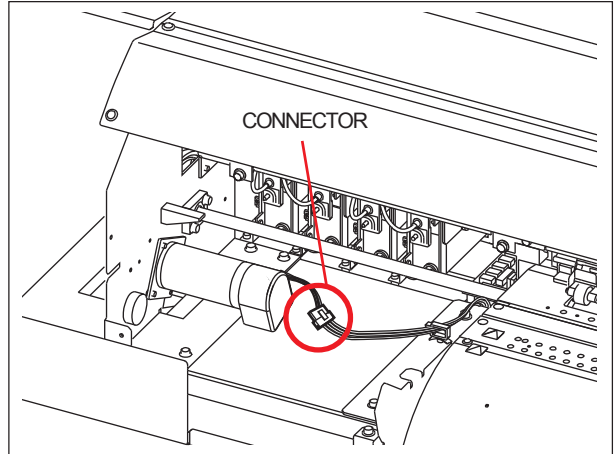

6 Remove the screw as shown in the figure to remove the Grit Encoder Board together with the stay.

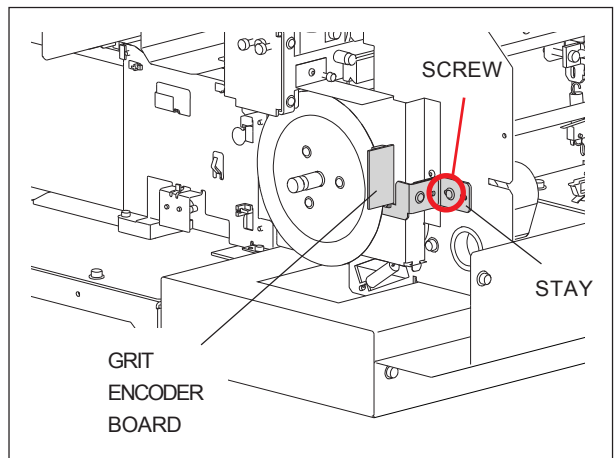

7 Remove the 3 screws as shown in the figure to remove Grit Encoder Stopper.

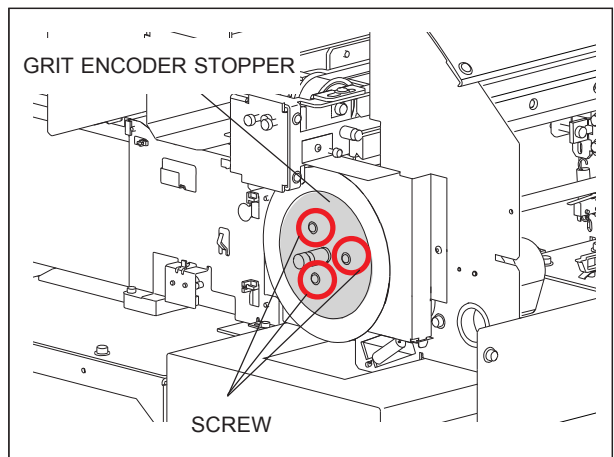

8 Remove the Grit Encoder.



Make sure not to scratch or leave any fingerprints on the Grit Encoder.

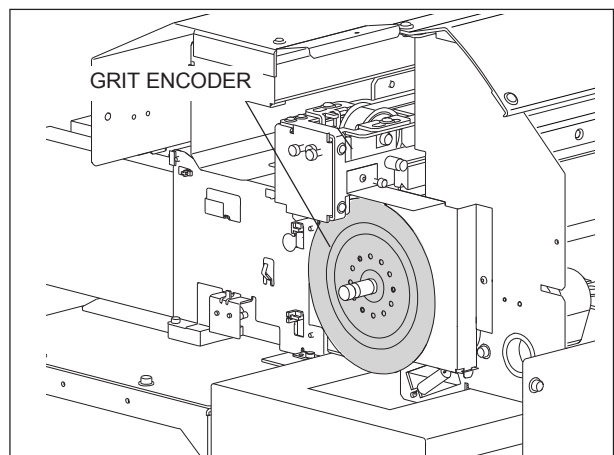

- 9 Remove the 4 rivets as shown in the figure, and slide the Gear Cover to the front side, and remove it.

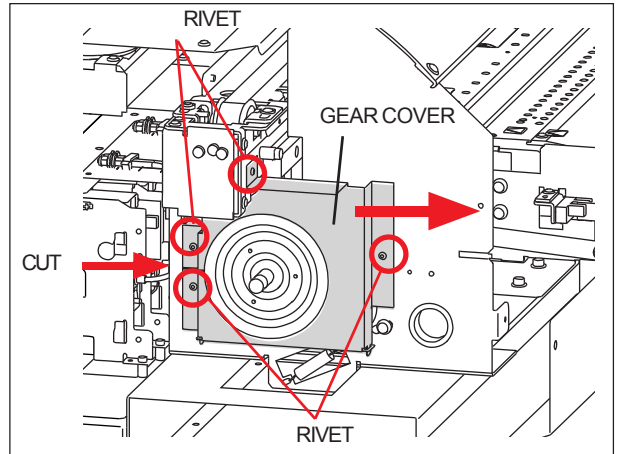

- 10 Remove the spring.

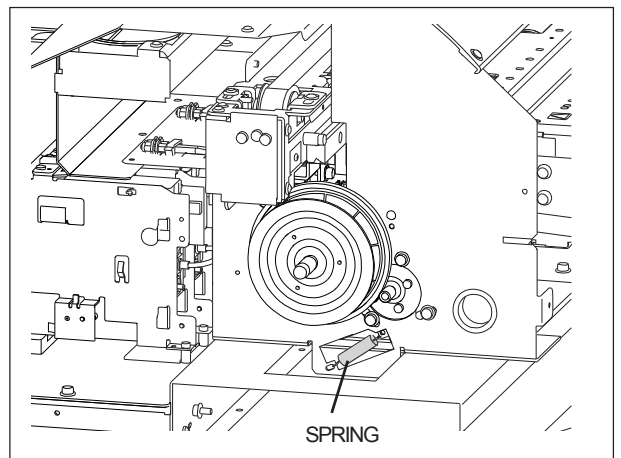

- 11 Remove the 3 screws fixing the Flange, and remove the motor together with the Flange.

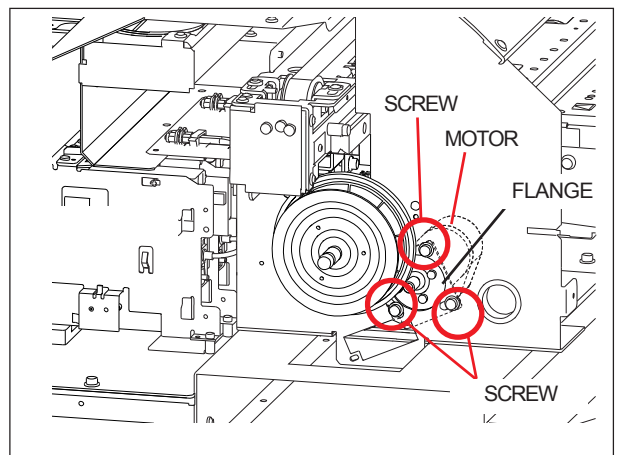

- 12 Remove the 4 screws as shown in the figure to remove the motor from the Flange.
And fix the new motor to the Flange.



Be careful with the fixing direction of the Flange.

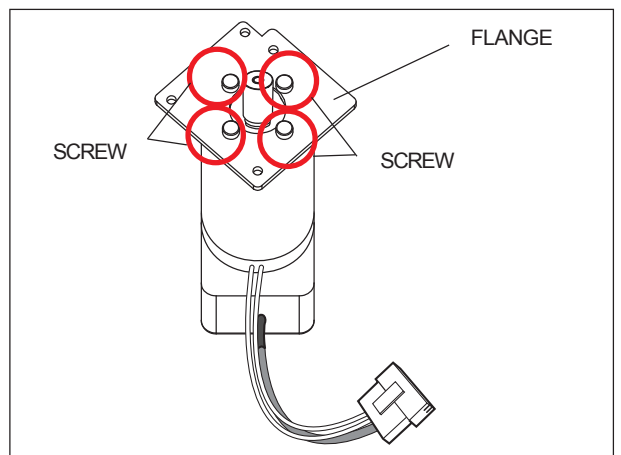

13 Fix the Flange with the 3 screws temporarily.

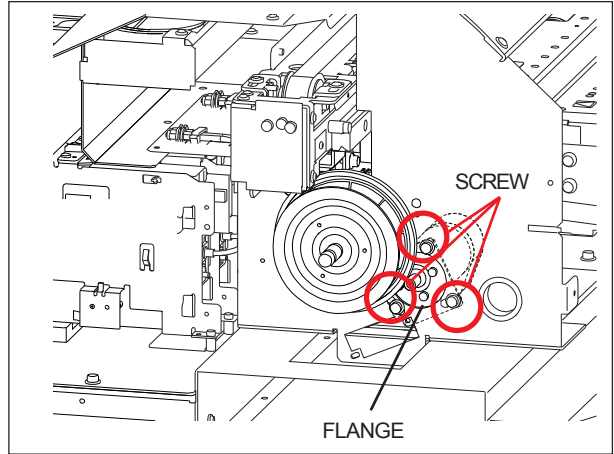

14 Fix the spring.

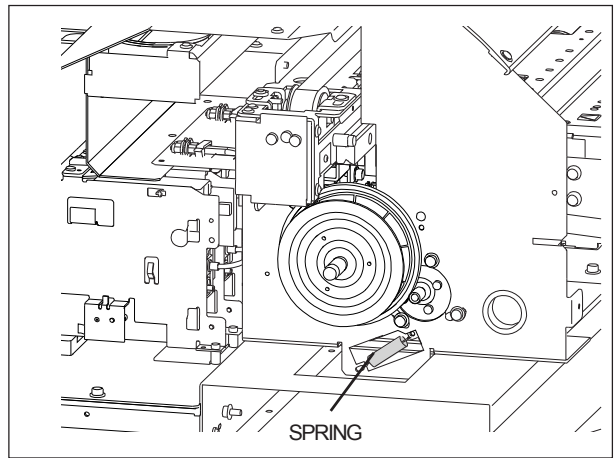

Revised 1

15 Turn the gear by hand and check there is no backlash all the way around.

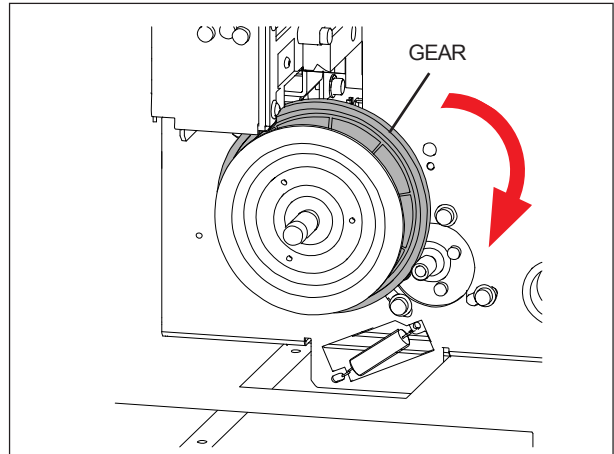

16 Tighten up the 3 screws to fix the Flange in the order shown in the figure.



Apply a proper quantity of grease (FLOIL G902) between gears.

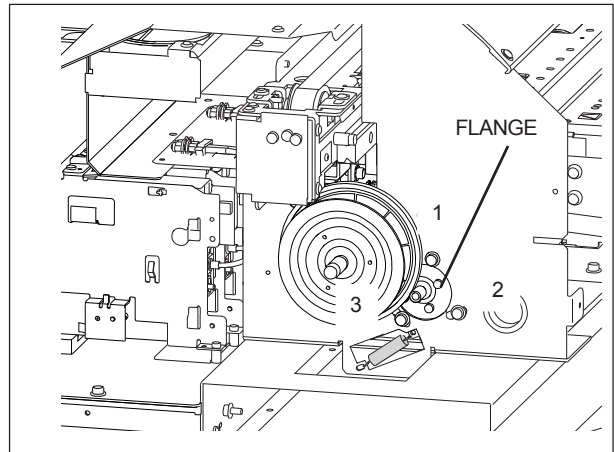

- 17** Slide the Gear Cover to the back side, and fix the Gear Cover with the 4 rivets.

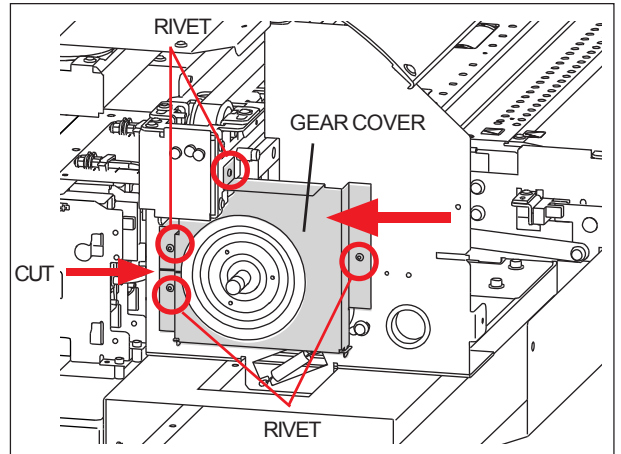

Revised 1

- 18** Rotate the Shaft to check that the Gear does not touch the Gear Cover.

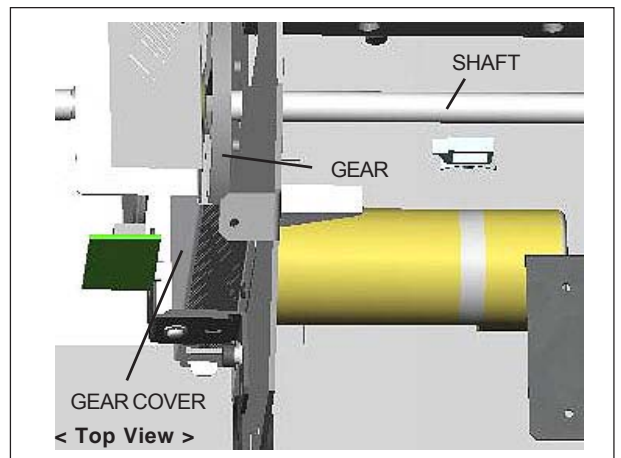

- 19** Fix the Grit Encoder.



The both sides of the Grit Encoder is the same.
When fixing the Grit Encoder, make sure not to scratch or leave any fingerprints on the Grit Encoder.

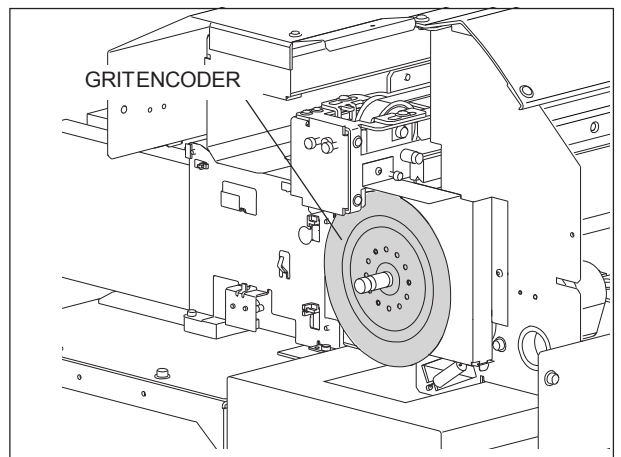

- 20** Fix the Grit Encoder Stopper with the 3 screws as shown in the figure while holding the Shaft.

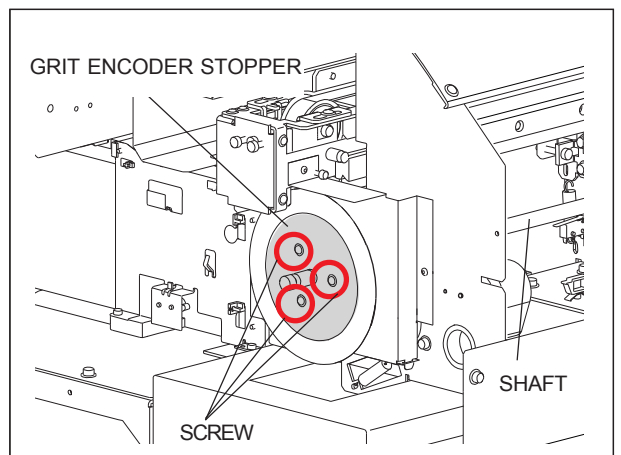

- 21** Fix the Grit Encoder Board together with the stay so that the Grit Encoder is in between the gap of sensor.



Adjust the position of the sensor so that the clearance with the Grit Encoder is around 1mm.

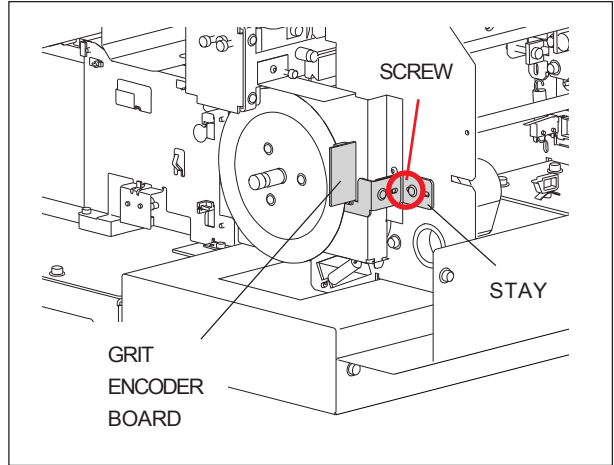
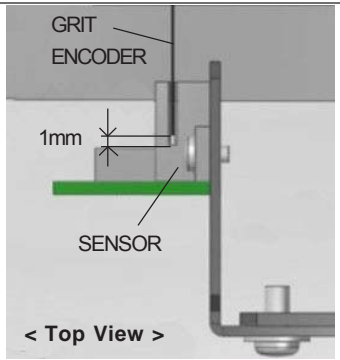

Revised 1

- 22** Rotate the Shaft to check that the Grit Encoder does not touch the sensor.



In case that the Grit Encoder touches the sensor, loosen the screw as shown in the figure to adjust the sensor by moving right and left.

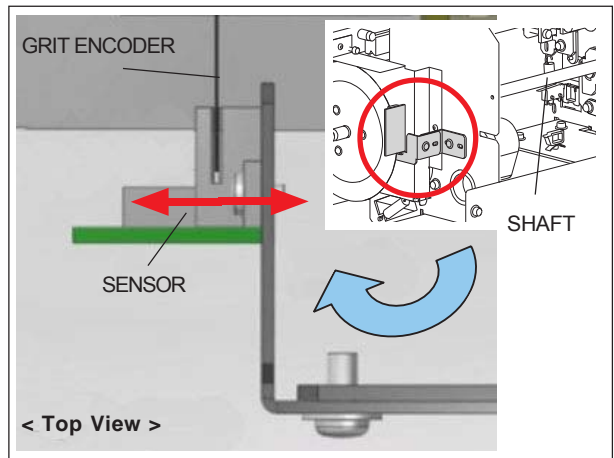
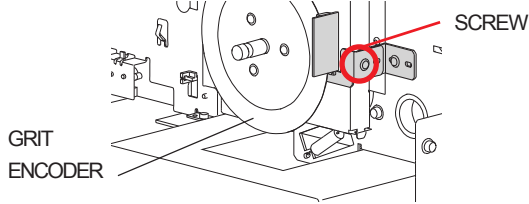

- 23** Connect the connector of the Motor Cable and fix it to the Clamp.

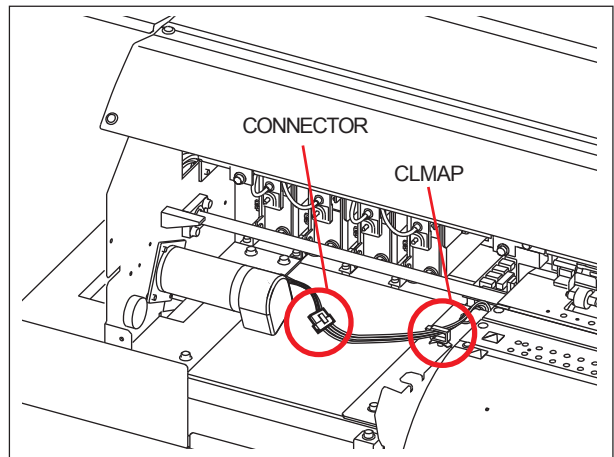

- 24** Fix the Cutter Frame.



When fixing the Cutter Frame, fix the sensor cable on the back side to the Clamp.

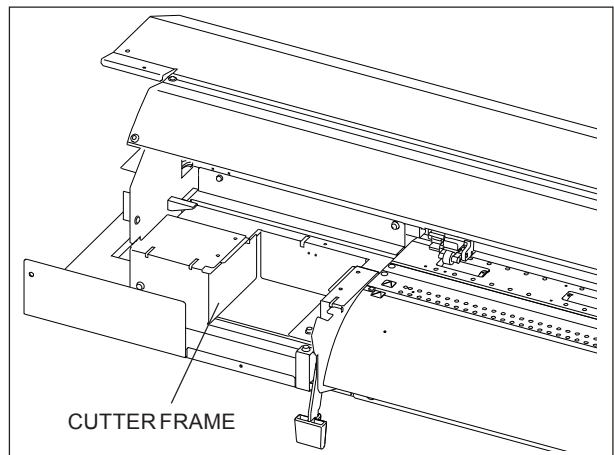
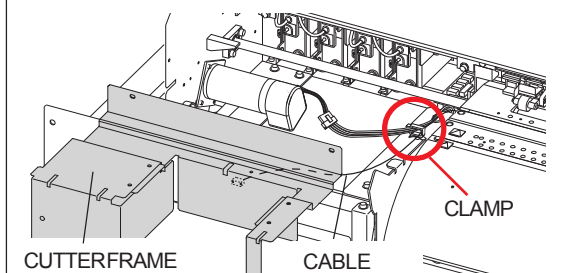

- 25 Connect the connector of the sensor cable to the Feed Motor Board.

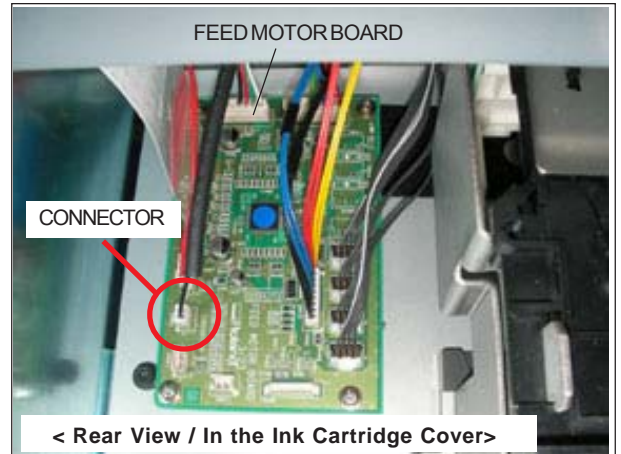

- 26 Perform the SERVO LOCK CHECK.
After turning on the main power, turn on the sub power while pressing the left, right and down keys to enter the Service Mode.

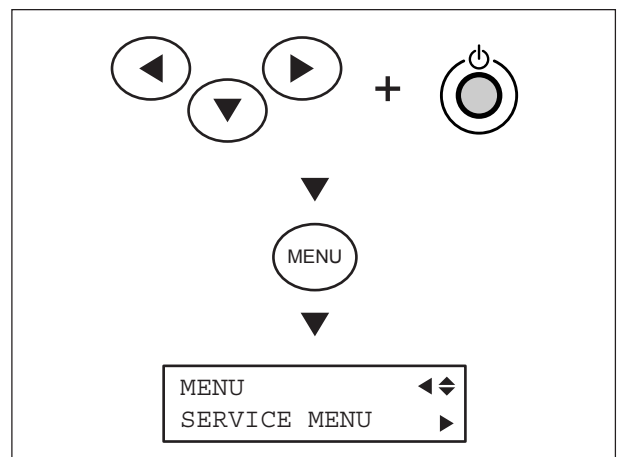

- 27 In [MOTOR MENU] > [SERVO LOCK] menu, select [F]. Rotate the Grit Roller back and forth by hand and make sure the value on the LCD changes depending on the movements.

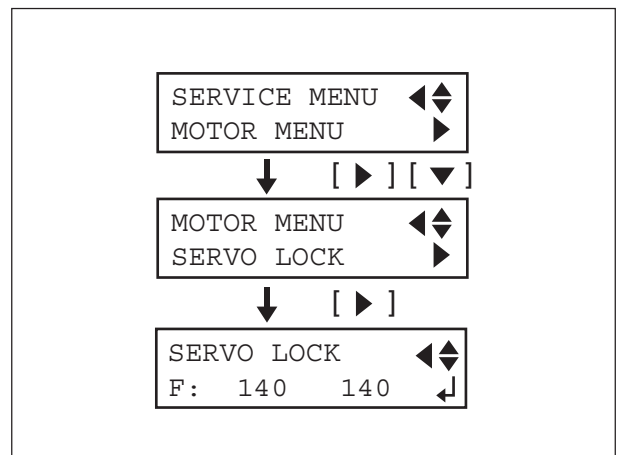

- 28 Press the [ENTER] key to excite the motor.
Check the Grit Roller can not be rotated easily by hand and the value on the LCD doesn't change.

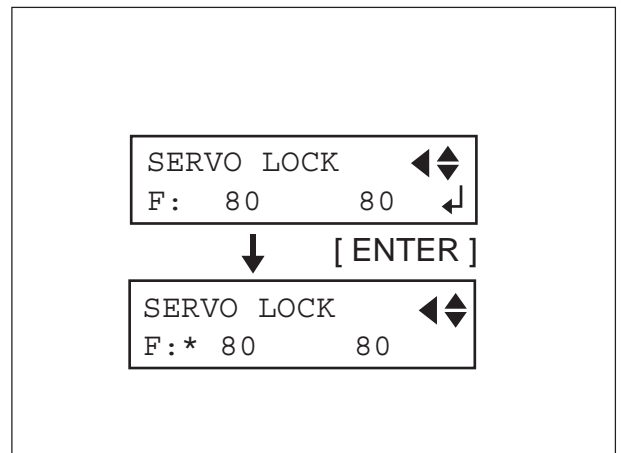

- 27** Check the Grit Encoder.
 Go back to the [MOTOR MENU], and select [G-ENC. CHECK] and press the [ENTER] key. Make sure the Grit Encoder functions correctly by confirming the display to show [G-ENC. CHECK COMPLETED].

In case that [G-ENC. CHECK FAILED] appears, check the followings.

1. Grit Encoder is fixed correctly.
2. Feed Motor is fixed correctly.
3. There are no scratches or fingerprints.

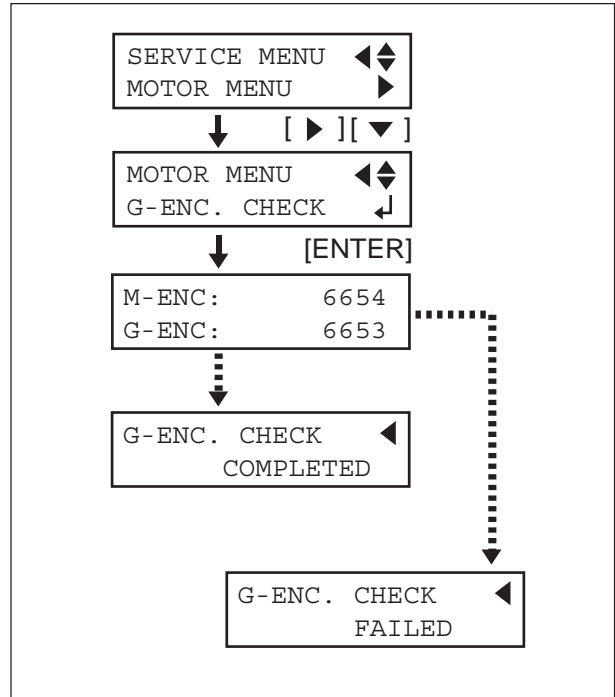

- 30** Perform AGING.
 Go back to the [MOTOR MENU], and select [AGING] > [FEED] and press the [ENTER] key. Make sure the machine performs AGING and then, finish it by pressing [ENTER] key.



Do not load any media when performing [AGING].

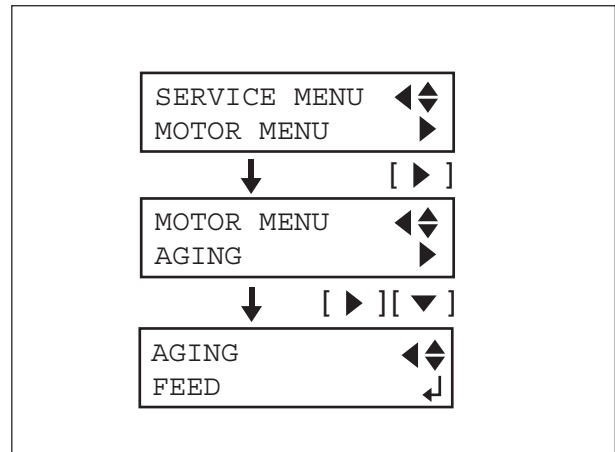

- 31** Clear the motor working hours.
 Go back to the Service Menu, and select [HISTORY MENU] > [MOTOR GROUP] > [MOTOR HOURS F] > [CLEAR] and press the [ENTER] key. The motor working hours will be reset to 0.

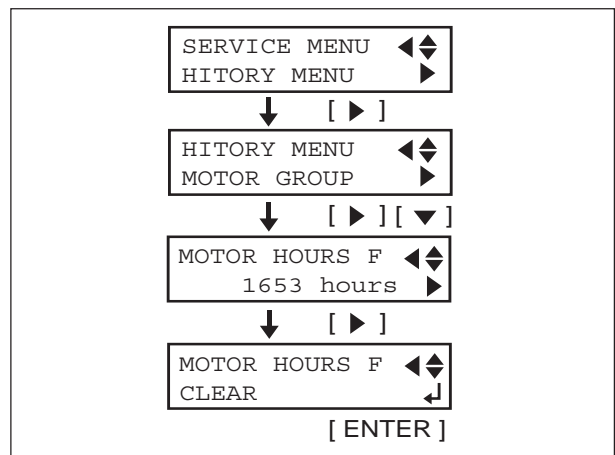

3-7 PUMP REPLACEMENT

- 1 Turn off the sub power, and then turn off the main power.

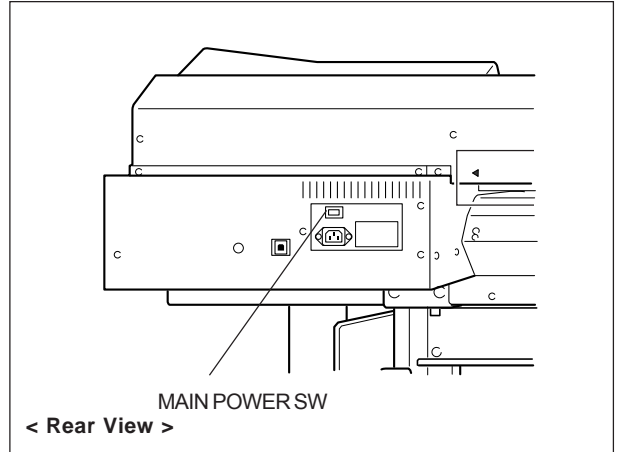

- 2 Remove the I/S Cover.

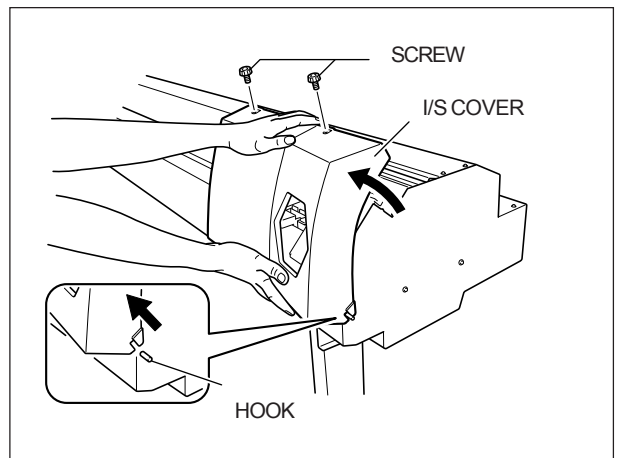

- 3 Unlock the Head Carriage and move it leftward by hand.

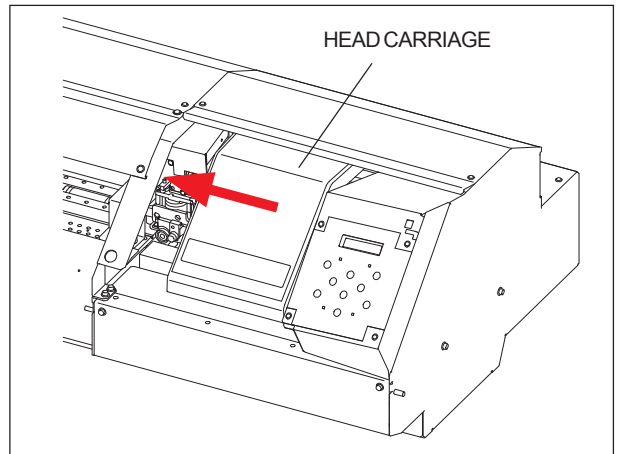

- 4 Remove the Pump Cover and Panel Cover.



When removing the Panel Cover, remove the sensor on the back side of the Panel Cover and flexible cable on the Panel Board.

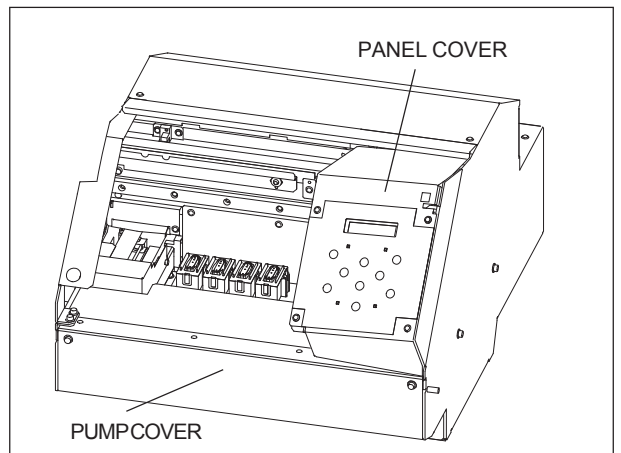
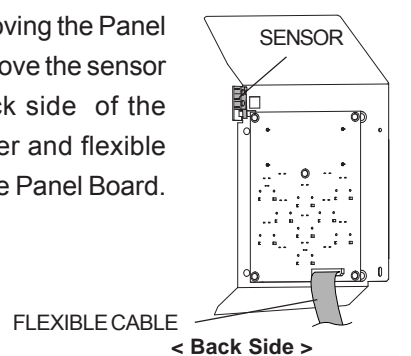

5 Remove the connector of the motor.

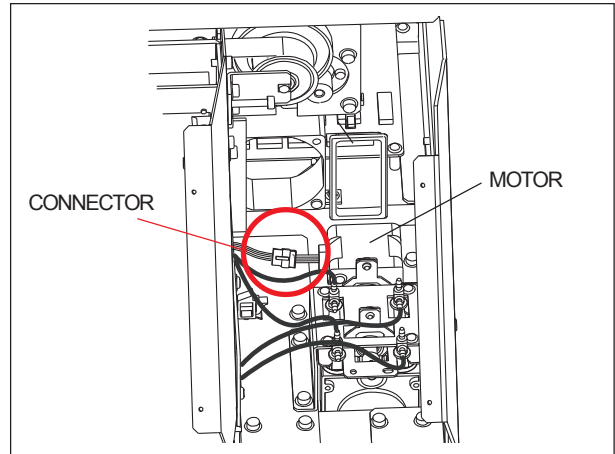

6 Disconnect the tubes of the Cap Top and the tubes of the Drain from the pumps.

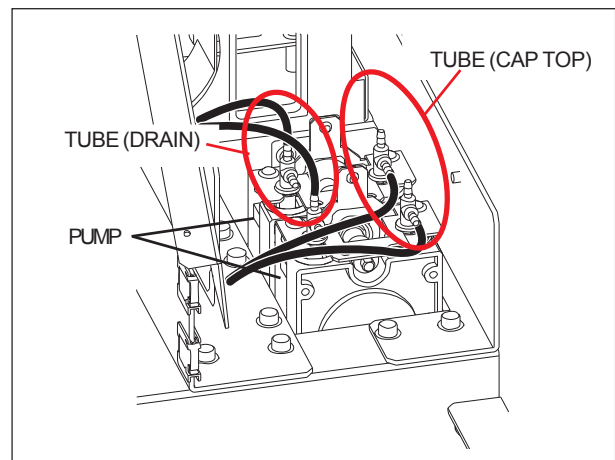

7 Remove the 2 screws as shown in the figure to remove the Pump Unit.

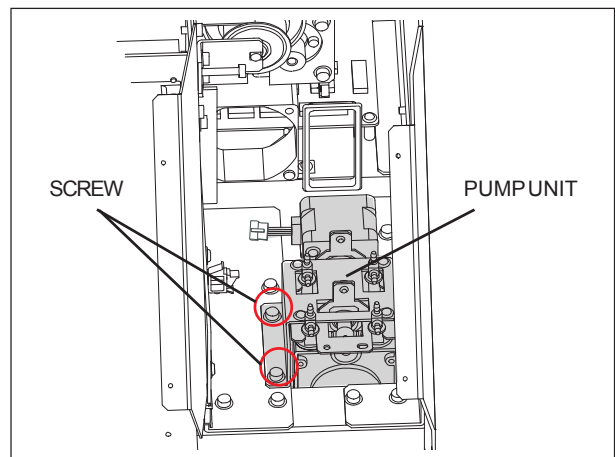

8 Remove the 4 screws as shown in the figure to remove the Pump Unit Stay.

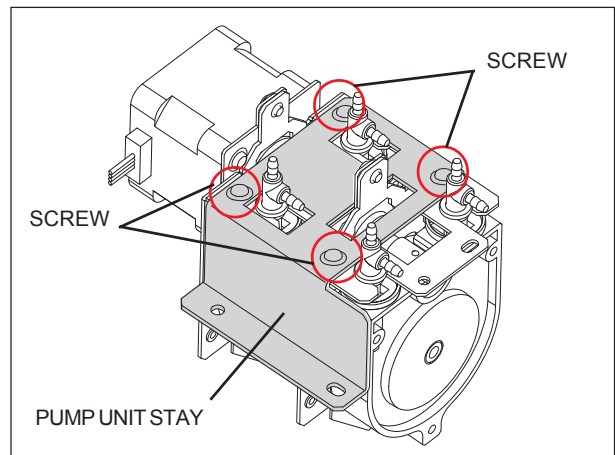

9 Separate the 2 pumps.

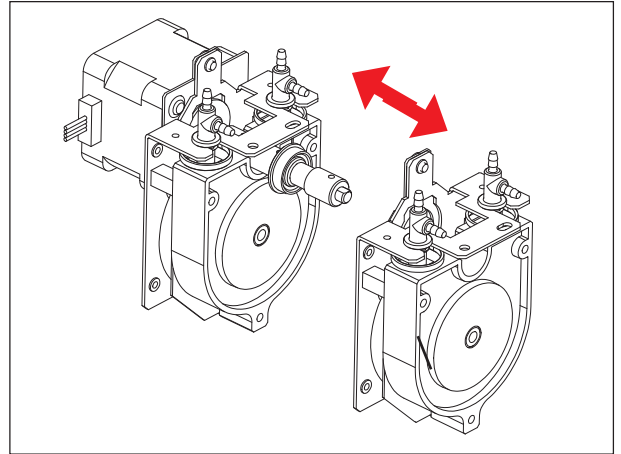

10 Replace with the new pump.

< Procedure for pump with the motor >

1) Remove the setscrew as shown in the figure to remove the gear and bearing from the Shaft.

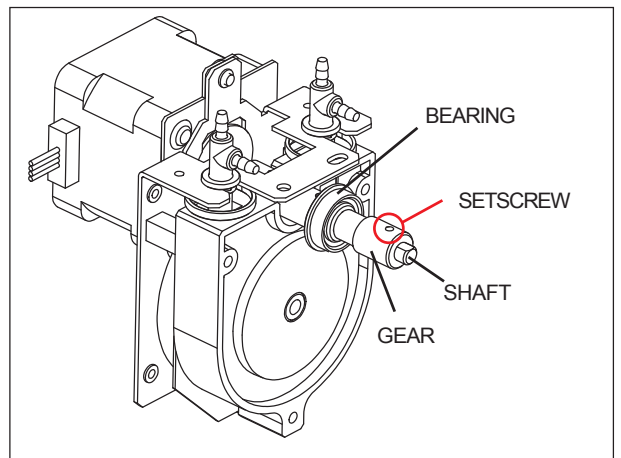

2) Remove the 3 screws as shown in the figure to remove the pump from the motor.

Fix the new pump to the motor.

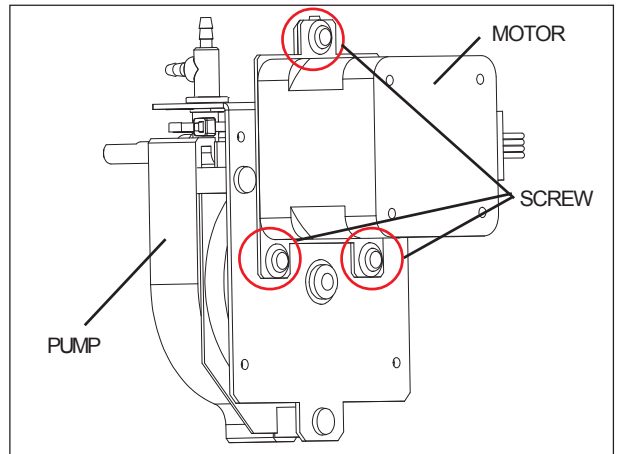

3) Set the bearing and gear to the Shaft.



Be careful with the fixing direction of the bearing and gear.

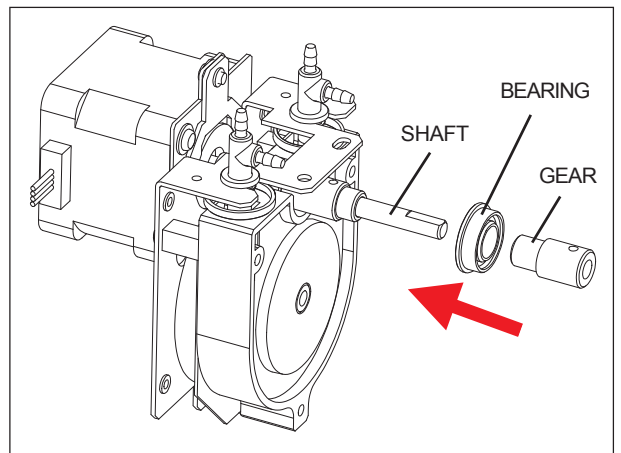

- 4) Fix the setscrew at the D-cut part by pushing the gear against the bearing.

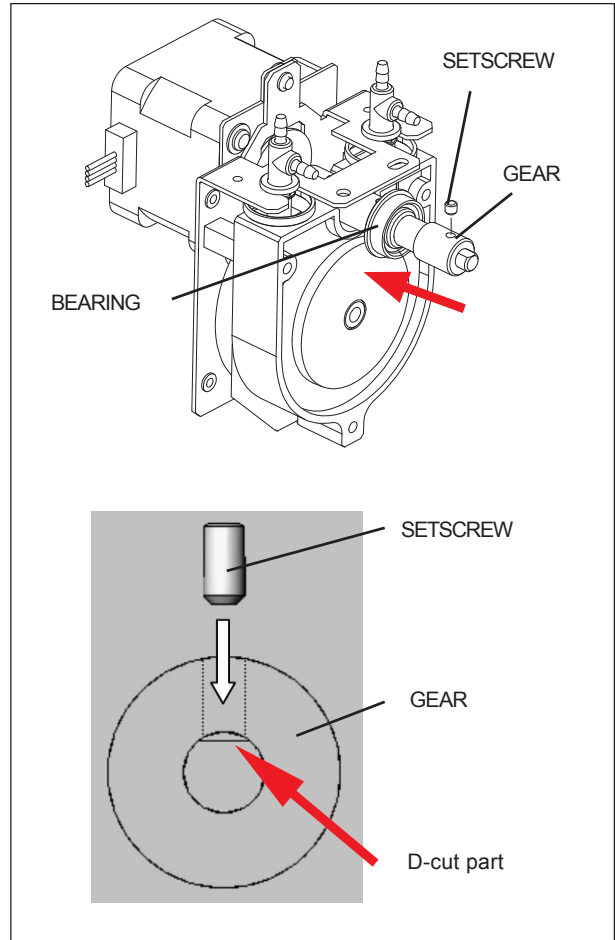

< Procedure for pump without the motor >

- 1) Remove the 3 screws as shown in the figure to remove the plate from the pump, and fix it to the new pump.

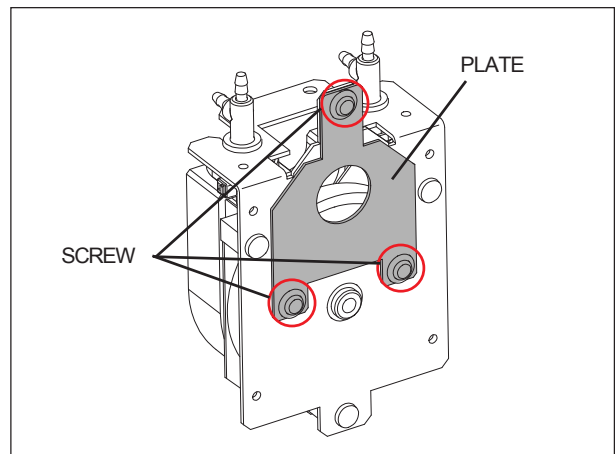

- 11** Assemble the 2 pumps.

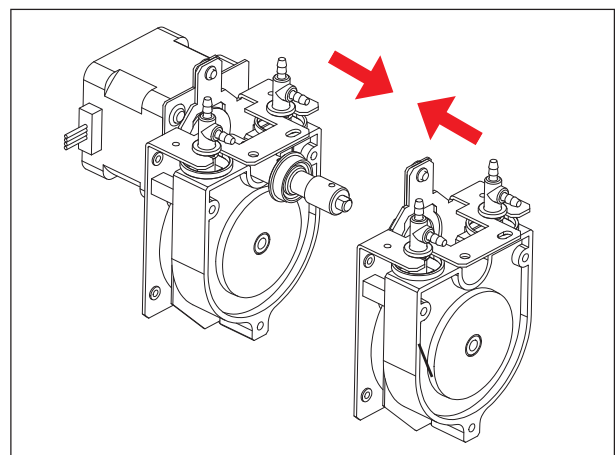

12 fix the Pump Unit Stay with the 4 screws as shown in the figure.

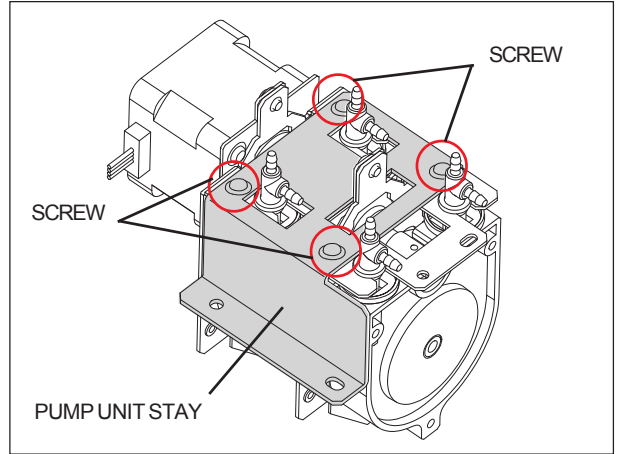

13 Fix the Pump Unit with the 2 screws as shown in the figure.

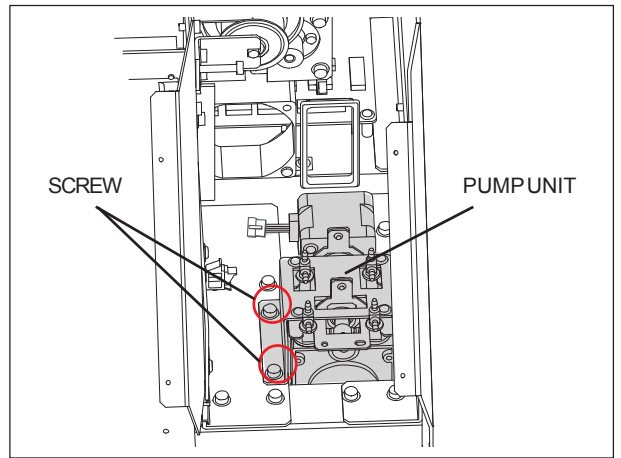

14 Connect the tubes of the Cap Top and the tubes of the Drain to the pumps.



Connect the tubes as shown in the figure.

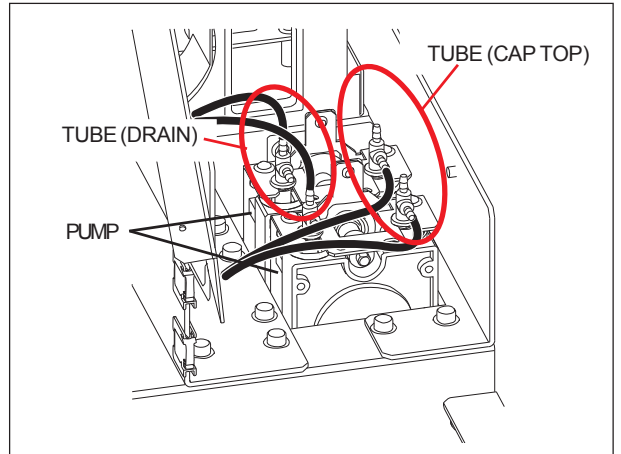
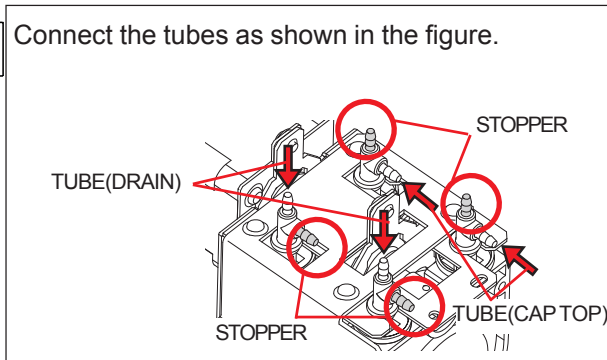

15 Connect the connector of the motor.

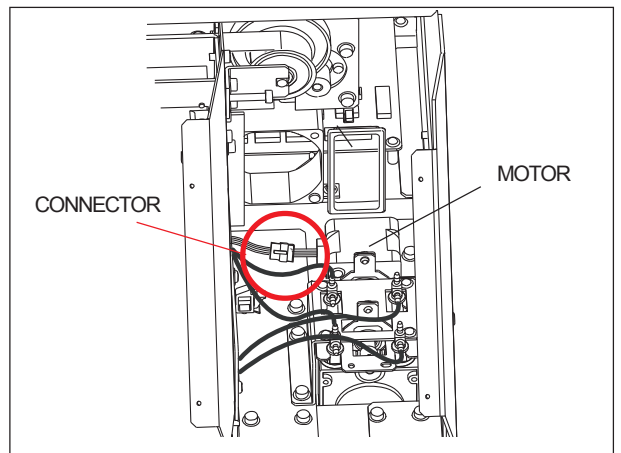

16 Fix the Pump Cover and Panel Cover.



When fixing the Panel Cover, fix the sensor on the back side of the Panel Cover and connect the flexible cable on the Panel Board.

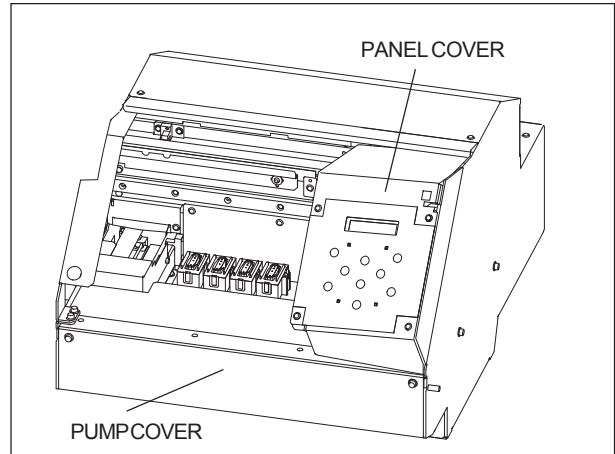
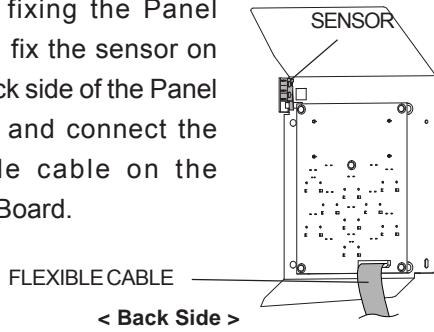

17 Turn on the main power, then turn on the sub power while pressing the left, right and down keys to enter the Service Mode.

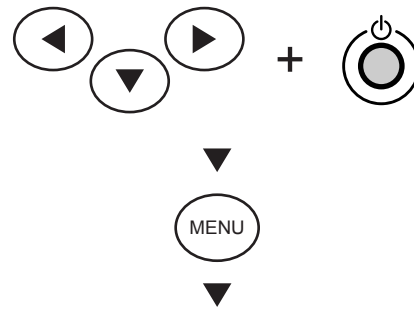

18 Select [SERVICE MENU] > [I/S MENU] > [PUMP CHECK], and perform [PUMP SUCTION] and [PUMP RELEASE] to check the pumps work correctly.

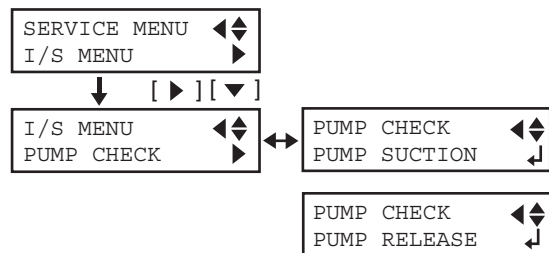

19 Clear the pump times. Select [SERVICE MENU] > [HISTORY MENU] > [MOTOR GROUP] > [PUMP TIMES] > [CLEAR], and press the [ENTER] key.

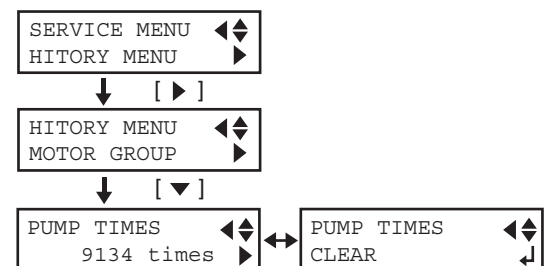

20 Move the Head Carriage by hand to the lock position.

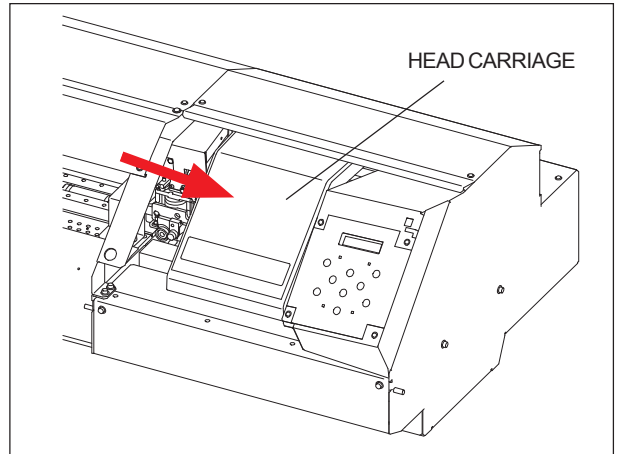

21 Fix the I/S Cover.

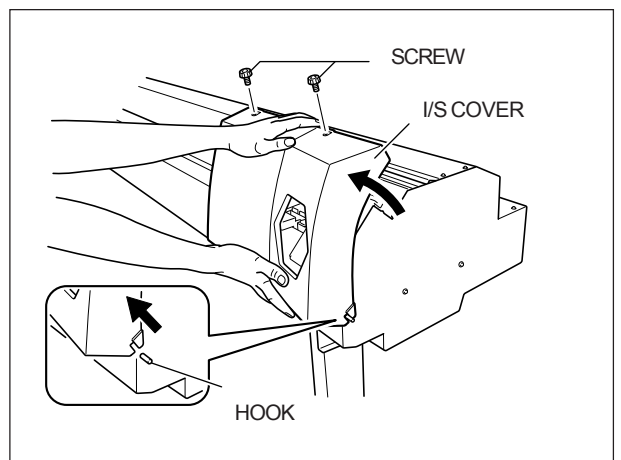

3-8 INK TUBE REPLACEMENT

- 1** Turn on the sub power while pressing the left, right and down keys to enter the Service Mode.

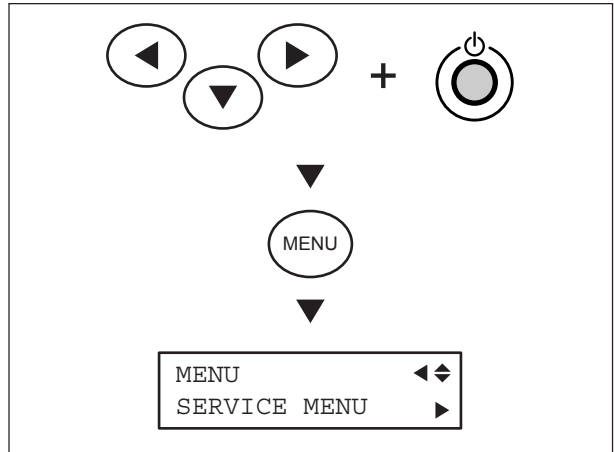

- 2** Select [SERVICE MENU] > [SUB MENU] > [PUMP UP], and remove ink by following the sequence.

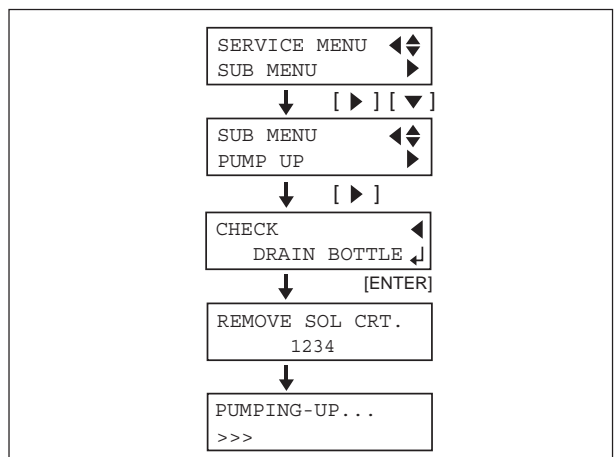

- 3** Turn off the sub power, and then turn off the main power.

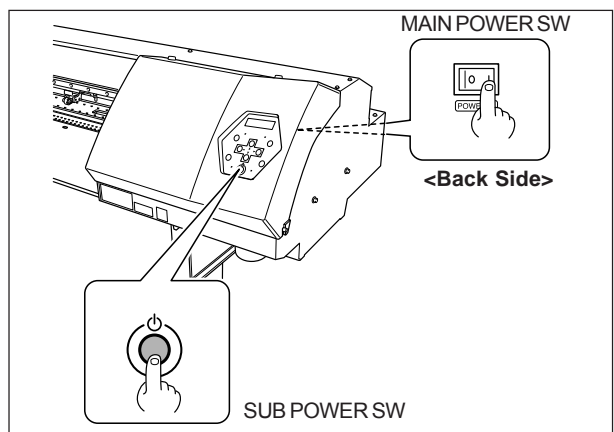

- 4** Remove the following covers.

- I/S Cover
- MaintenanceCover
- Left Side Cover
- Front Cover
- Top Cover
- Right Top Cover

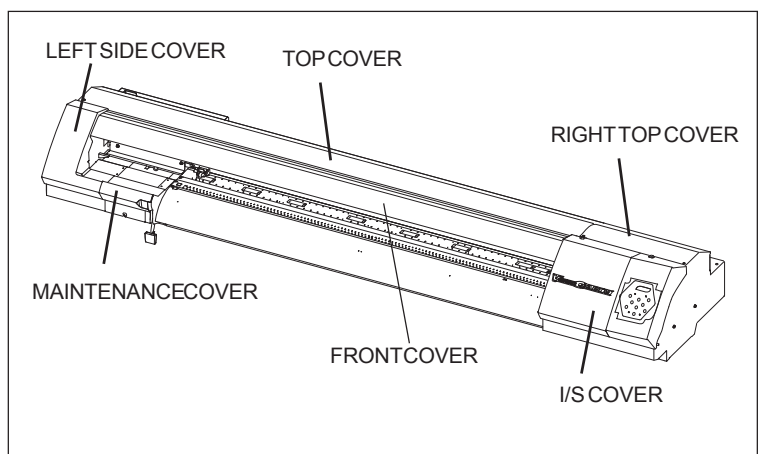

Revised 3

5 Remove the Cut Cable Guide.

< VP-300 >

1) Remove the 3 screws to remove the Cut Cable Guide.

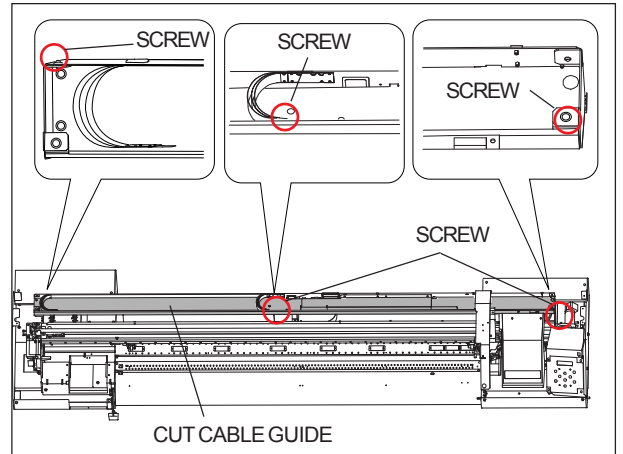

< VP-540 >

1) Remove the 3 screws to remove the Cable Support.



Pull the flexible cable to access the screw.

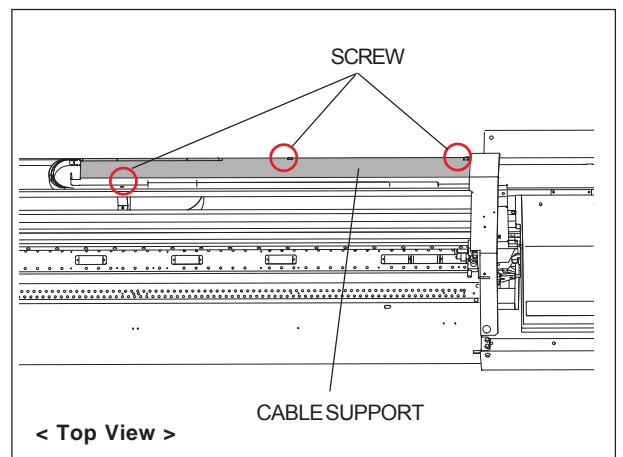
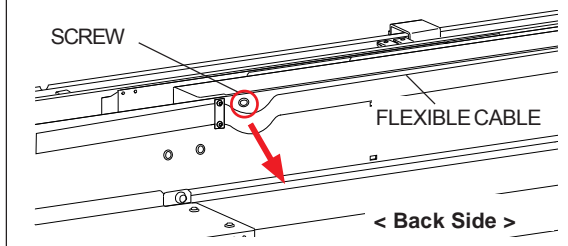

2) Remove the 3 screws to remove the Cut Cable Guide.

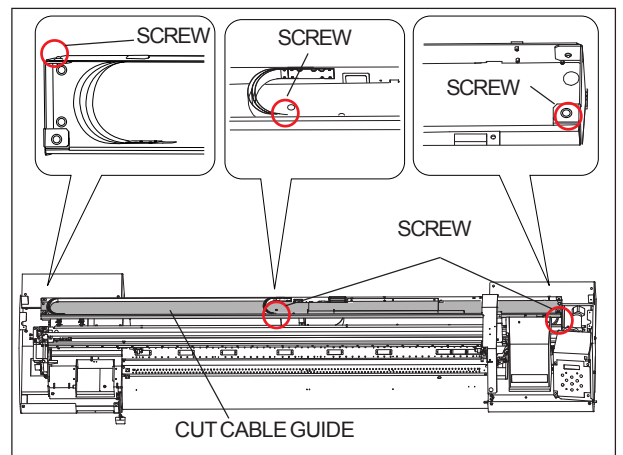

6 Remove the Carriage Cover.

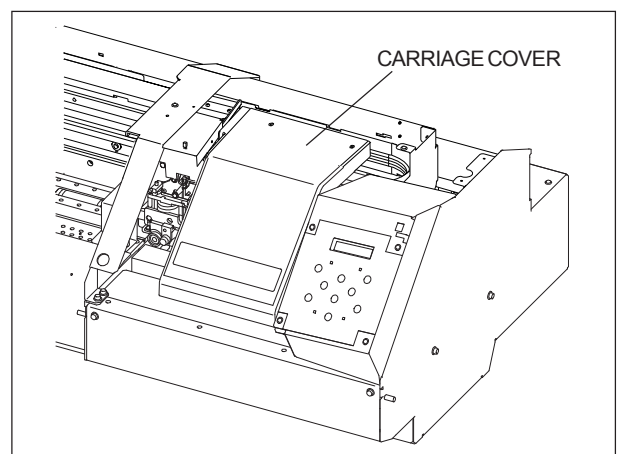

- 7** Disconnect the ink tubes (Carriage Side) from the Y tube joints, and put the scotch tape at the tip of the ink tube to prevent the ink from coming out.



It is not necessary to replace the ink tubes of the other side (Carriage Side) of the joints.

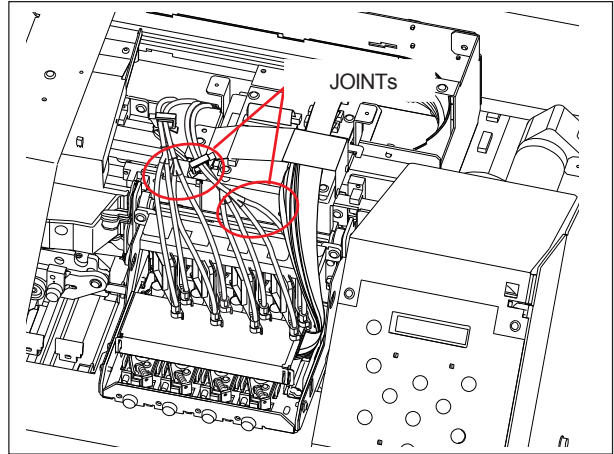

- 8** Disconnect the ink tubes (Cartridge Side) from the tube joints, and put the scotch tape at the tip of the ink tube to prevent the ink from coming out.



It is not necessary to replace the ink tubes of the other side (Cartridge Side) of the joints.

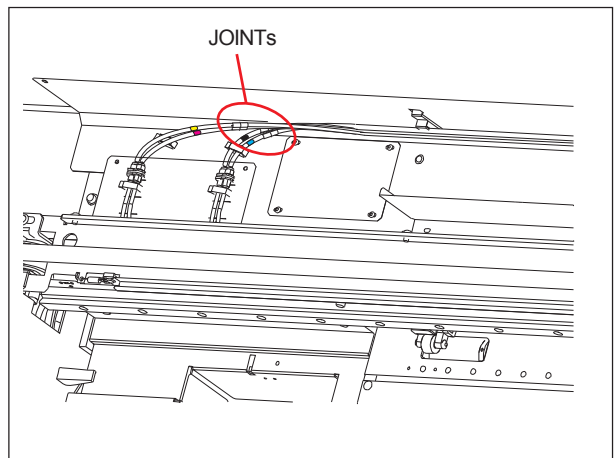

- 9** Pull out the ink tubes, and put the new ink tubes in the Tube Guides.



Each four tubes are connected, and the lengths of both ends are different.

Be careful with the fixing direction of tubes.

P/No. P/Name

1000002670 TUBE,SJ-RDG3*44LINKVP-300

1000002681 TUBE,SJ-RDG3*44LINKVP-540

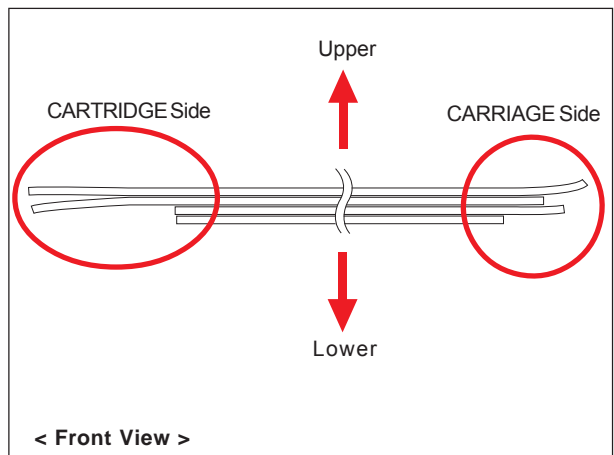

- 10** Connect the new ink tubes to the tube joints (Cartridge Side), and fix them to the Clamps.

Connect the tubes to the tube joints in the fixed positions with K on top as shown in the figure.

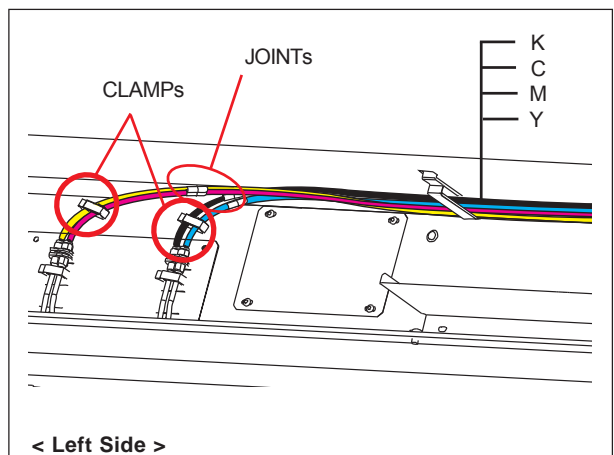



Make sure that the fixing direction of the Holder Cable Plate is correct.

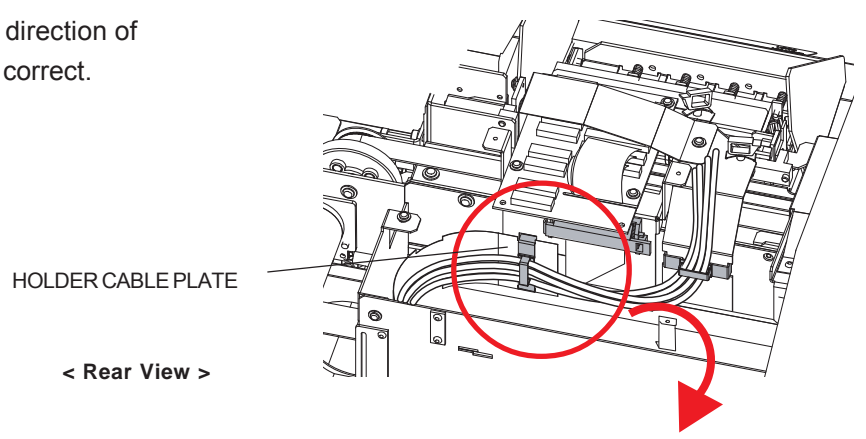

HOLDER CABLE PLATE

< Rear View >

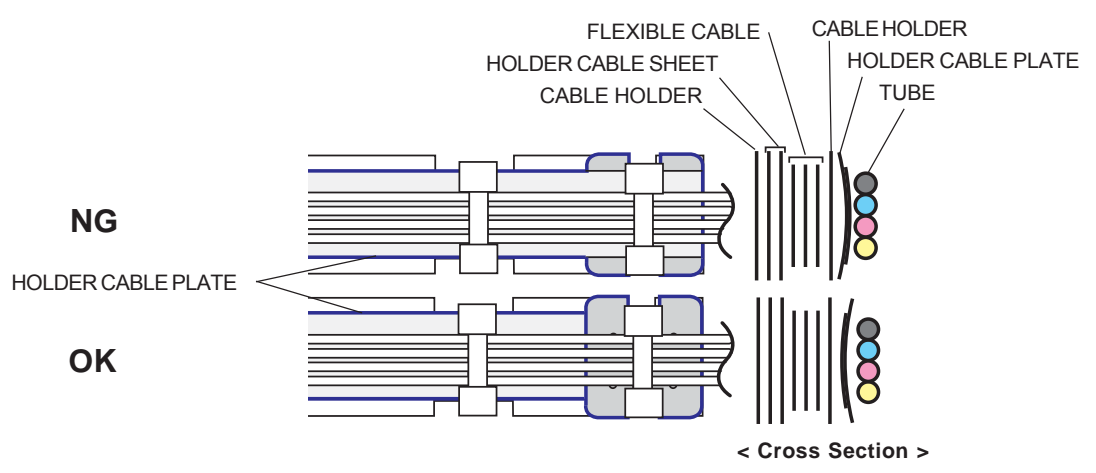

11 Cross the tubes (Carriage Side) two by two as shown in the figure, and fix them to the Clamps.

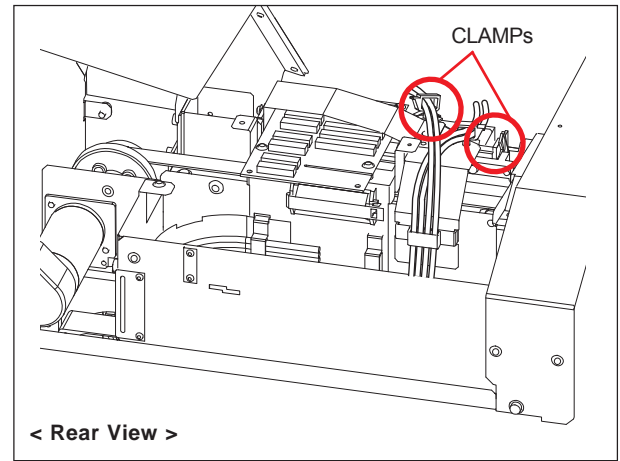

< Rear View >

12 Connect the tubes to the Y tube joints (Carriage Side).

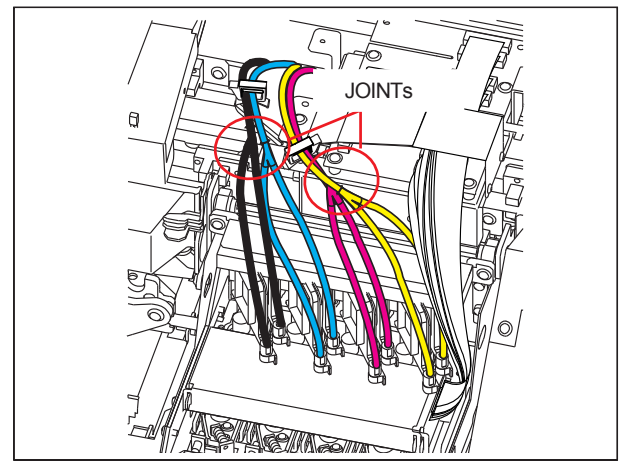

JOINTs

13 Fix the Carriage Cover.

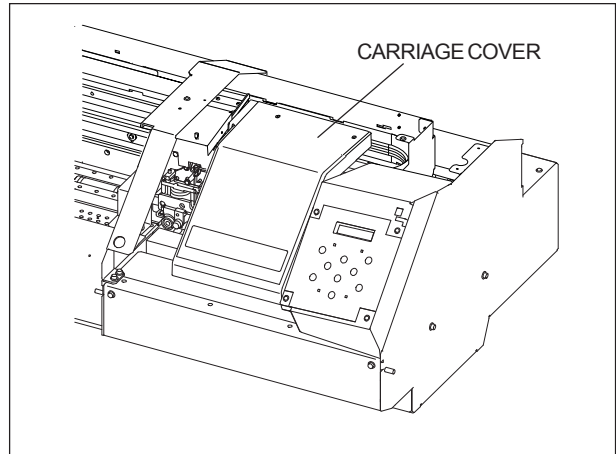

Revised 3

14 Fix the Cut Cable Guide.

< VP-300 >

1) Fix the Cut Cable Guide with the 3 screws as shown in the figure.

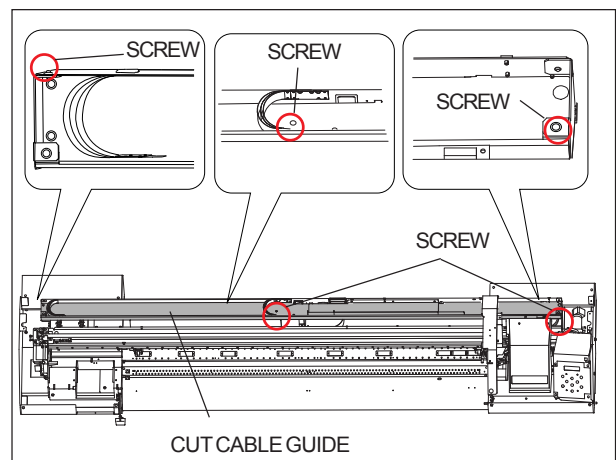

< VP-540 >

1) Fix the Cut Cable Guide with the 3 screws as shown in the figure.

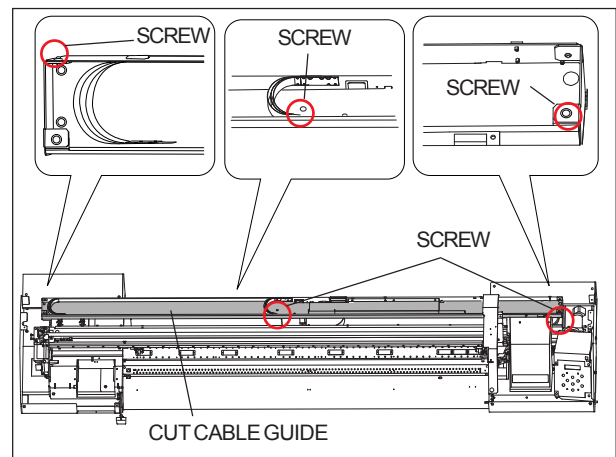

2) Fix the Cable Support with the 3 screws as shown in the figure.

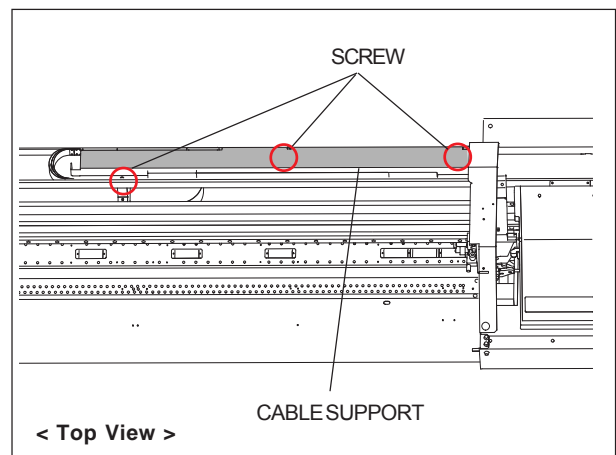

- 15 Adjust the position of the flexible cable so that it comes in the middle of the Protection Plates.

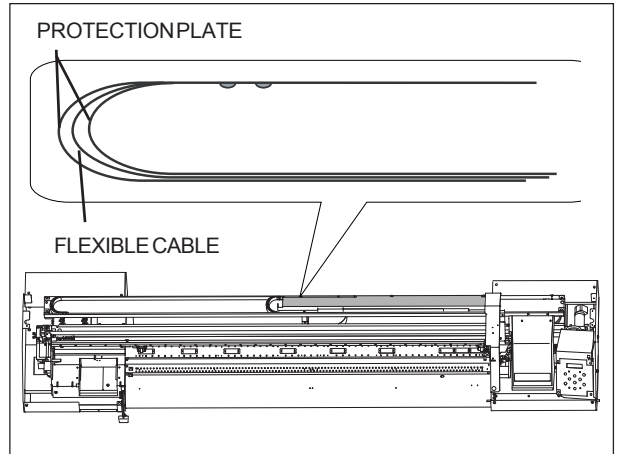

- 16 After turning on the main power, turn on the sub power while pressing the left, right and down keys to enter the Service Mode.

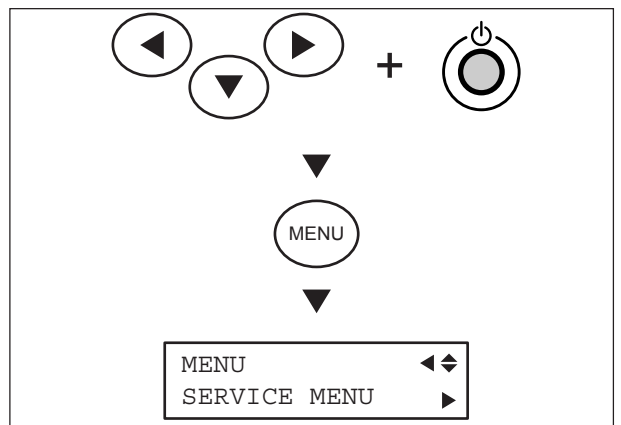

- 17 Select [SERVICE MENU] > [SUB MENU] > [FILL INK], and perform Ink Filling by following the sequences.

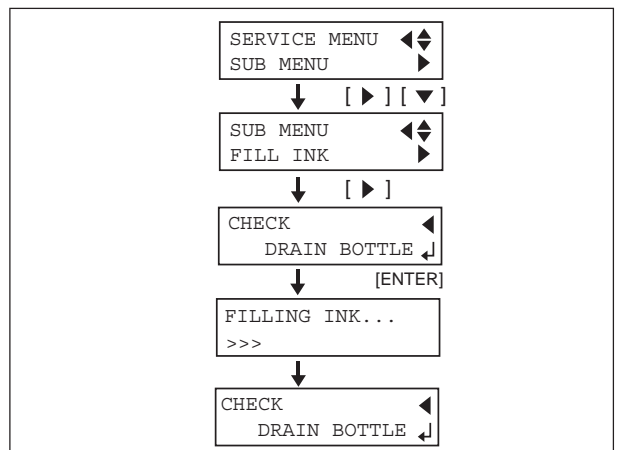

3-9 BOARDS REPLACEMENT (MAIN BOARD / SW POWER SUPPLY)

BOARD LAYOUT (IN CHASSIS)



MAINBOARD REPLACEMENT

MAIN BOARD CONNECTOR LAYOUT

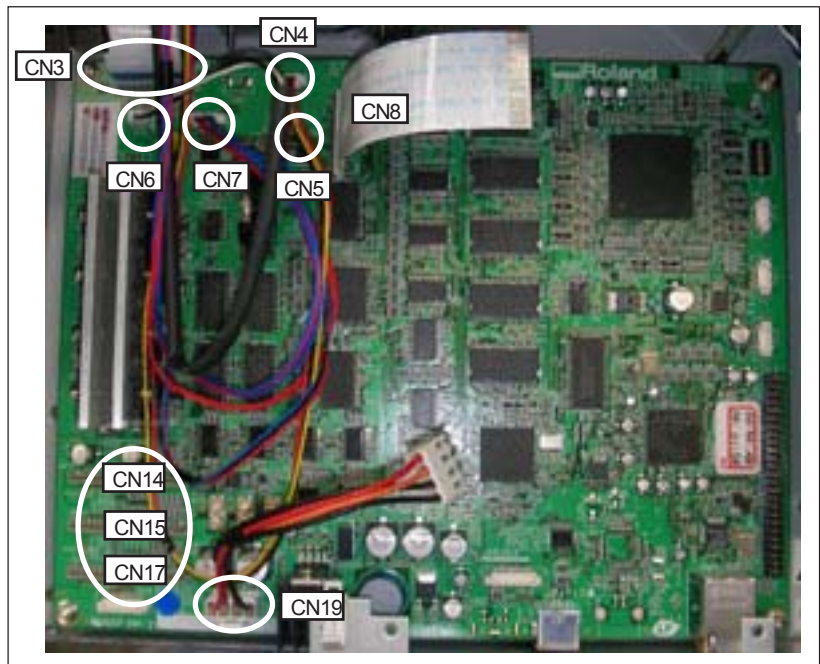

1 Turn on the main power.

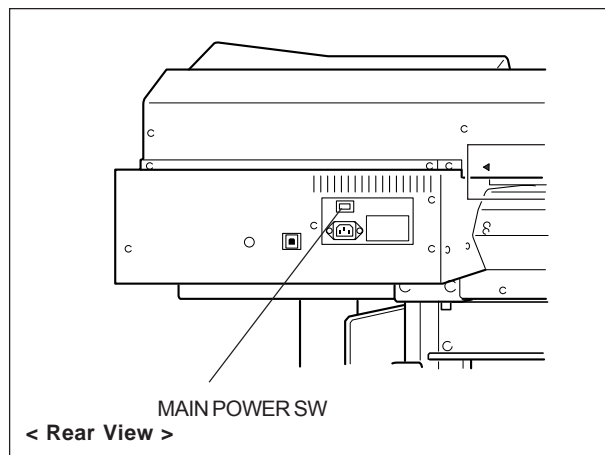

2 Start the Peck.

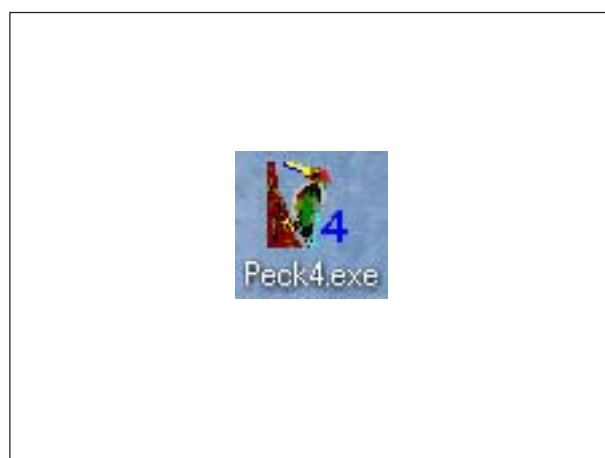

3 Perform [Get Report] and [Get Parameters], and save the Service Report and the parameters.



4 Turn off the main power and pull out the AC cord.

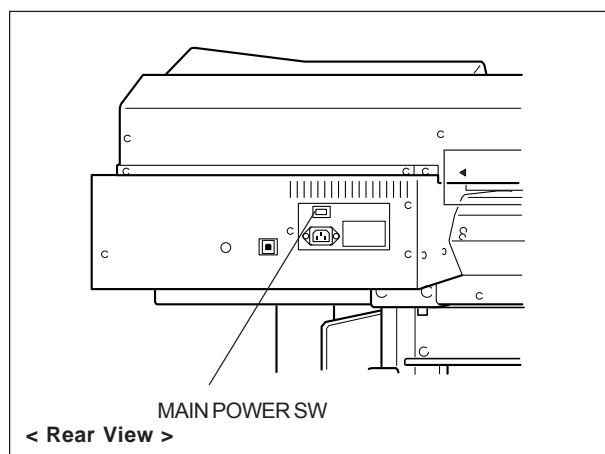

- 5** Remove the I/S Cover, Right Top Cover and Chassis Cover.

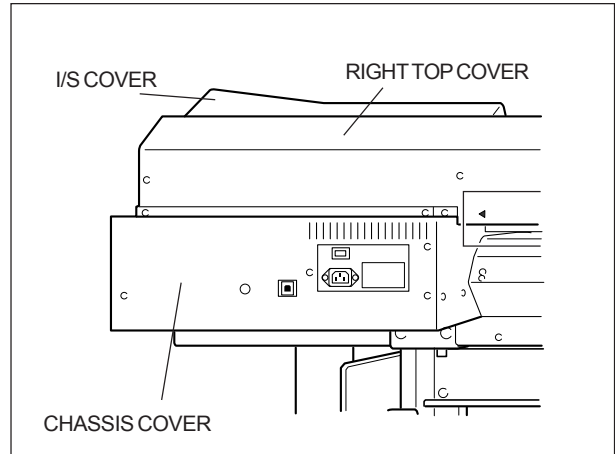

- 6** Remove the 4 screws as shown in the figure.

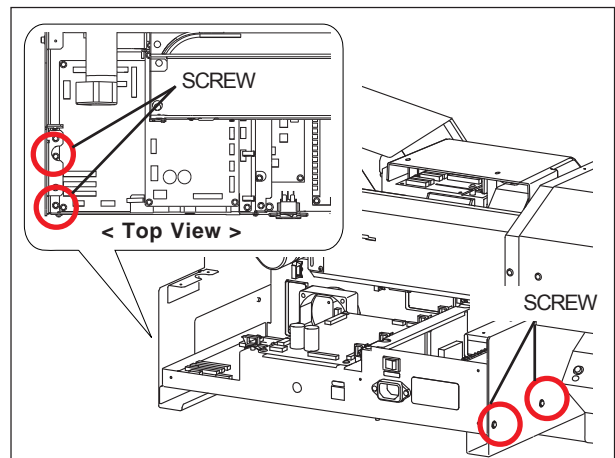

- 7** Disconnect the flexible cables and connector and remove the cables from the Clamps.

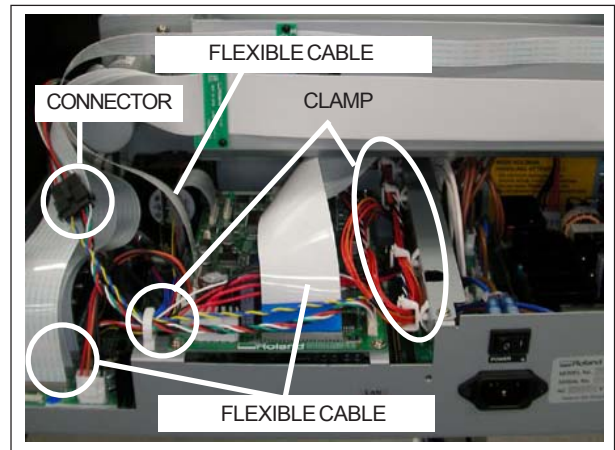

- 8** Pull out the Chassis to the front side.

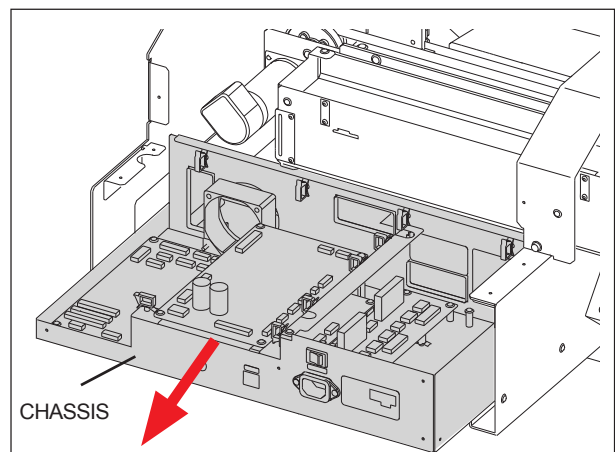

9 Disconnect all the cables from the Servo Board.



10 Remove the 4 screws as shown in the figure to remove the Servo Board.



11 Disconnect the cables as shown in the figure from the Main Board.

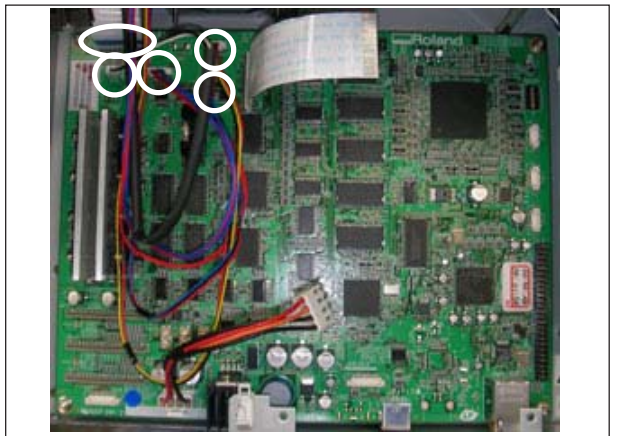

12 Disconnect the connector and flexible cable as shown in the figure and fix them to the new Main Board. Remove the 4 screws as shown in the figure and replace with the new Main Board.

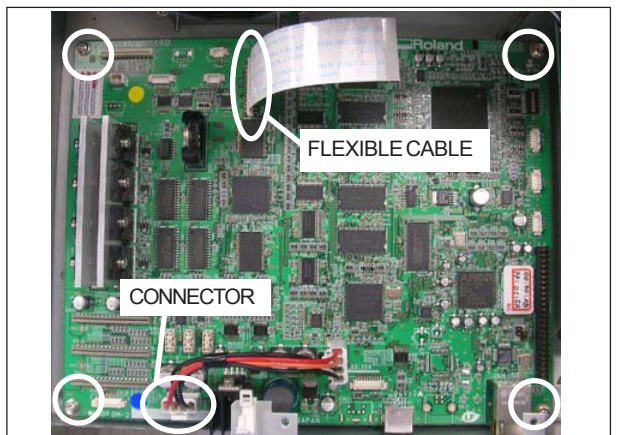

13 Connect the cables as shown in the figure to the Main Board.

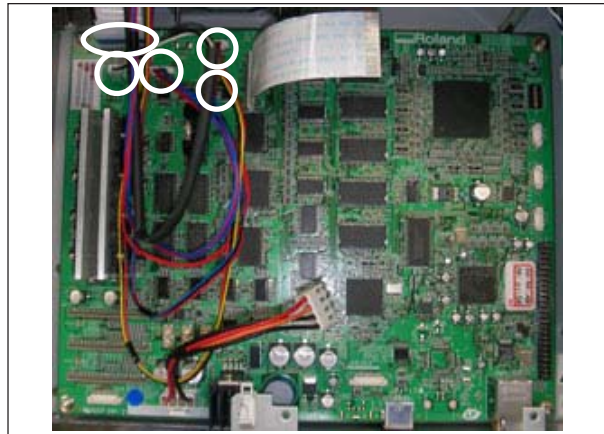

14 Fix the Servo Board with the 4 screws as shown in the figure.



15 Put back the Chassis.

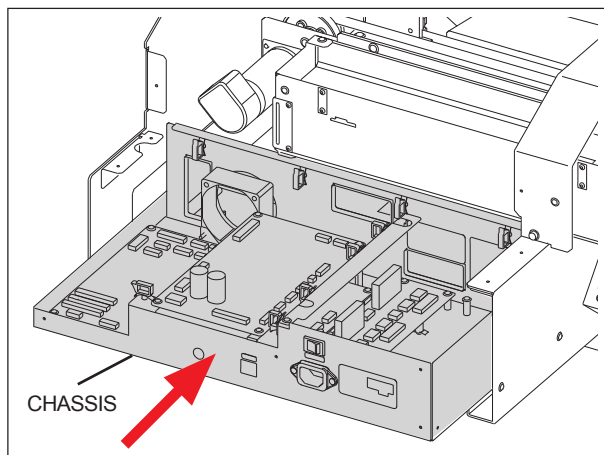

16 Connect all the cables to the Servo Board.

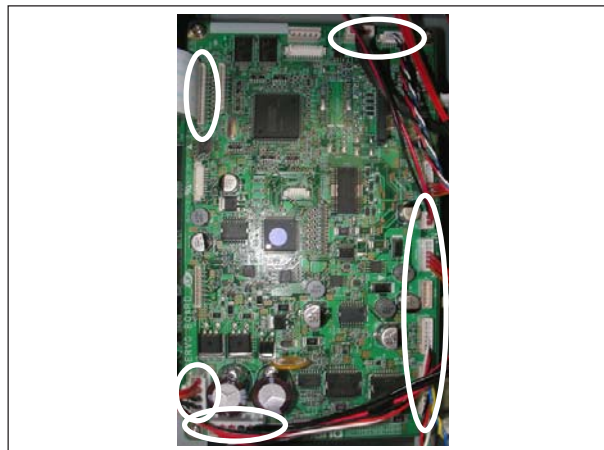

17 Fix the Chassis with the 4 screws as shown in the figure.

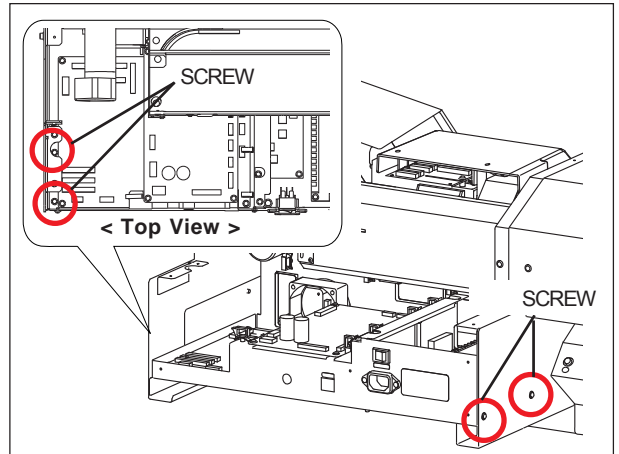

18 Connect the flexible cables and connector and fix the cables with the Clamps.

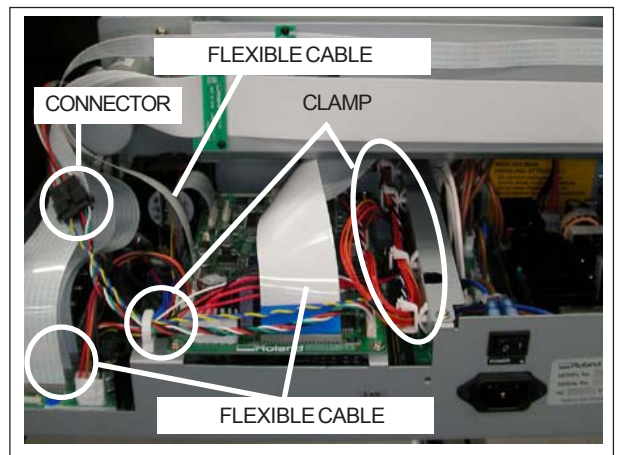

19 Perform the following operations after replacement.

1. DIP SW SETTING
2. BATTERY INSTALLATION
3. FIRMWARE INSTALLATION
4. SYSTEM PARAMETER INITIALIZE
5. IP ADDRESS SETTING

Start the machine with the Service Mode and set in the User Menu.

6. PUT PARAMETER
7. TIME AND DATE SETTING

Set the date and time in the [SERVICE MENU] > [SUB MENU] > [CLOCK].

Revised 4 *Set the [DATE] in order of the [Year/Month/Day].

8. FIRMWARE VERSION CONFIRMATION OF NETWORK CONTROLLER
9. SENSOR CHECK

It can be performed in the Sensor Check.

10. CROP MARK SENSOR ADJUSTMENT
11. CROP-CUT ADJUSTMENT

Necessary when the voltage is adjusted in the CROP MARK SENSOR ADJUSTMENT.

Perform the following operations if it is not possible to transfer the parameters by Peck4.exe.

1. DIP SW SETTING
2. BATTERY INSTALLATION
3. FIRMWARE INSTALLATION
4. SYSTEM PARAMETER INITIALIZE
5. TIME AND DATE SETTING

Set the date and time in the [SERVICE MENU] > [SUB MENU] > [CLOCK].

Revised 4 *Set the [DATE] in order of the [Year/Month/Day].

6. IP ADDRESS SETTING
Start the machine with the Service Mode and set in the User Menu.
7. FIRMWARE VERSION CONFIRMATION OF NETWORK CONTROLLER
8. HEAD RANK SETTING
9. SERIAL NUMBER INPUT
10. INK TYPE SETTING
11. SENSOR CHECK
It can be performed in the Sensor Check.
12. LIMIT & CUT DOWN POSITION INITIALIZE
13. FLUSHING POSITION ADJUSTMENT
14. LINEAR ENCODER SETUP
14. TOOL PRESSURE ADJUSTMENT
16. HEAD ALIGNMENT
Only Horizontal and Bidirectional Adjustments are required.
17. CALIBRATION
18. CROP MARK SENSOR ADJUSTMENT
19. CROP-CUT ADJUSTMENT
20. PRINT / CUT POSITION ADJUSTMENT

SW POWER SUPPLY REPLACEMENT (41V)
 SW POWER SUPPLY CONNECTOR LAYOUT

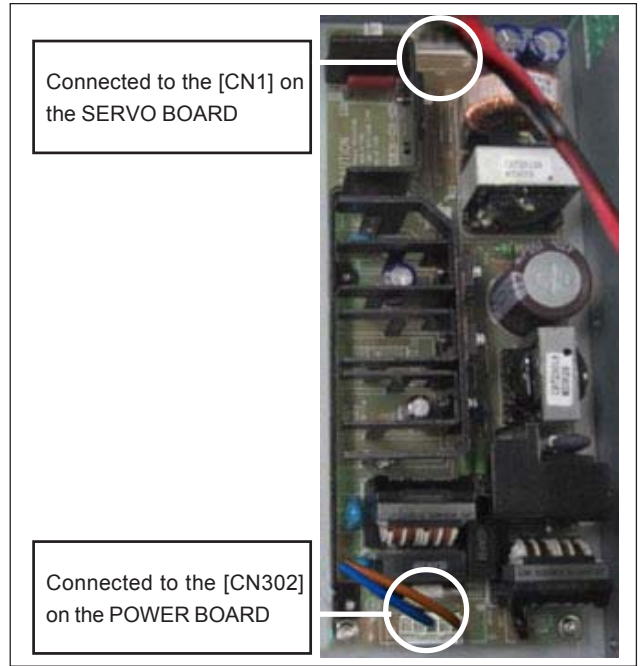

- 1 Turn off the sub power, and then turn off the main power and pull out the AC cord.

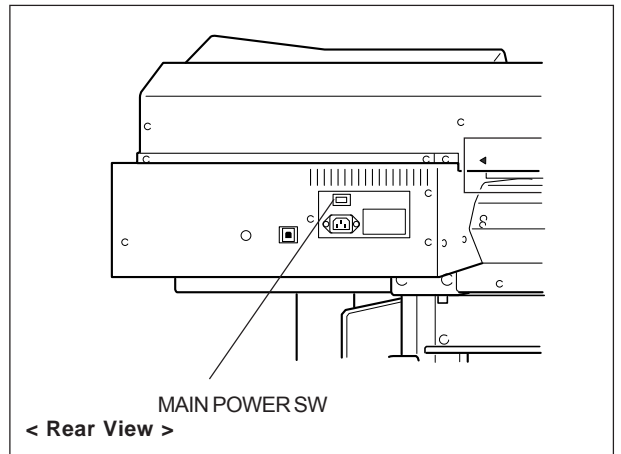

- 2 Remove the I/S Cover, Right Top Cover and Chassis Cover.

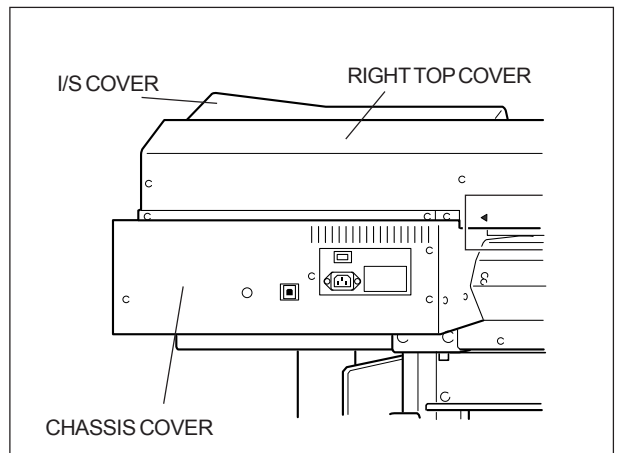

3 Remove the 4 screws as shown in the figure.

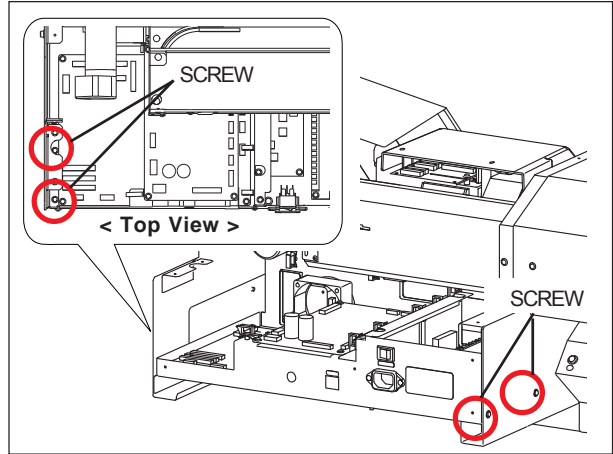

4 Disconnect the flexible cables and connector and remove the cables from the Clamps.

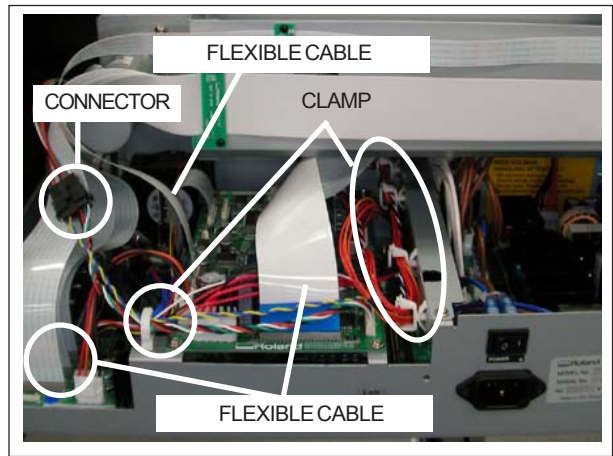

5 Pull out the Chassis to the front side.

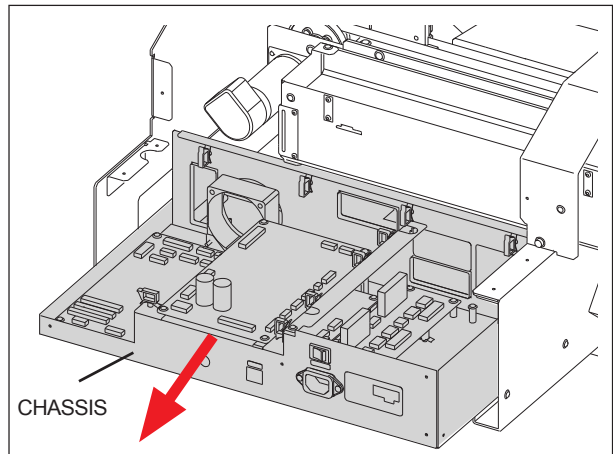

6 Disconnect all the cable from the SW Power Supply.



- 7** Remove the 4 screws as shown in the figure and replace with the new SW Power Supply.
Connect all the cables to the SW Power Supply.

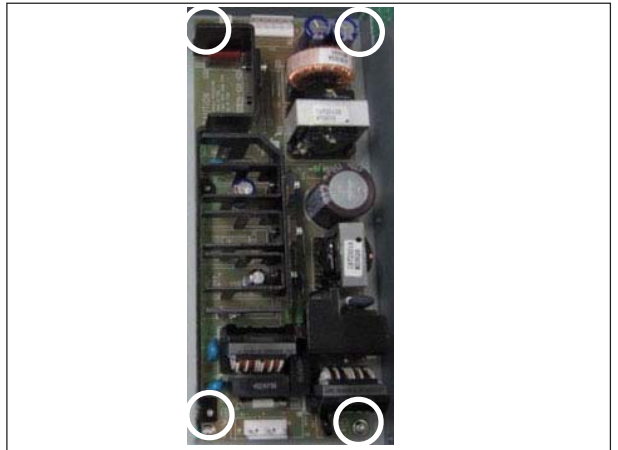

- 8** Set the output voltage of SW Power Supply to +41V.

1. Disconnect the connector on the Servo Board.



Make sure to disconnect the connector.

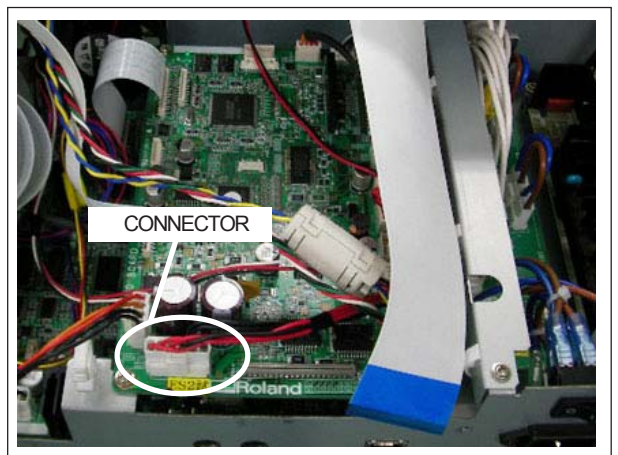

2. Turn on the main power.



Use the Digital Multi-Meter that can measure the direct voltage.

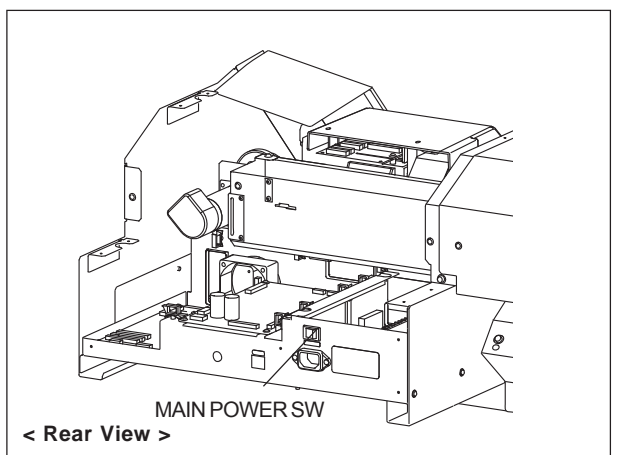

3. Put the black probe into CN51-1pin (GND) and the red probe into CN51-6pin (Vout) on the SW Power Supply.

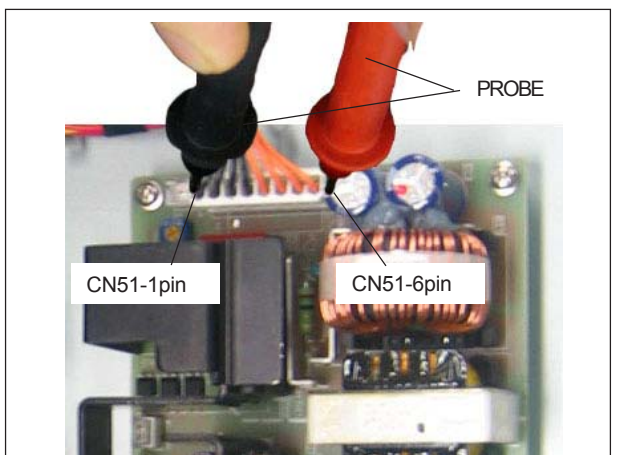

- Rotate the volume clockwise using the screwdriver to adjust the output voltage value to $+41\pm 0.1$.



When the output voltage exceeds the $+41.4V$, SW Power Supply does not output the voltage by the protection circuit on it. In this case, SW Power Supply will output the voltage by rotating the volume counterclockwise. When the protection circuit works, SW Power Supply may not output for a while. Measure the voltage some time later again.

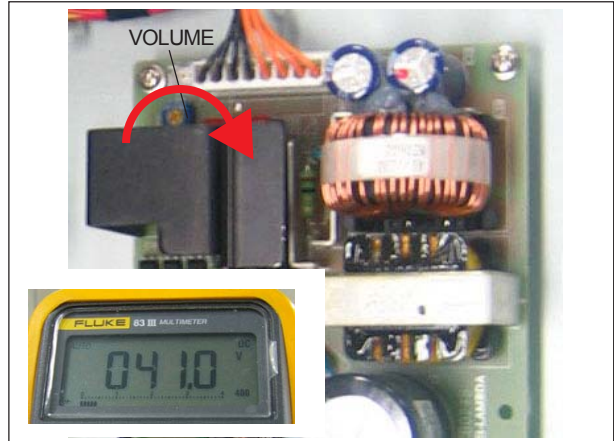

- Put back the Chassis.

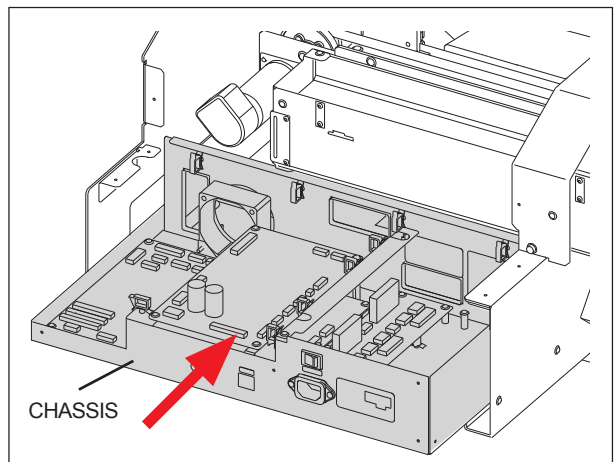

- Fix the Chassis with the 4 screws as shown in the figure.

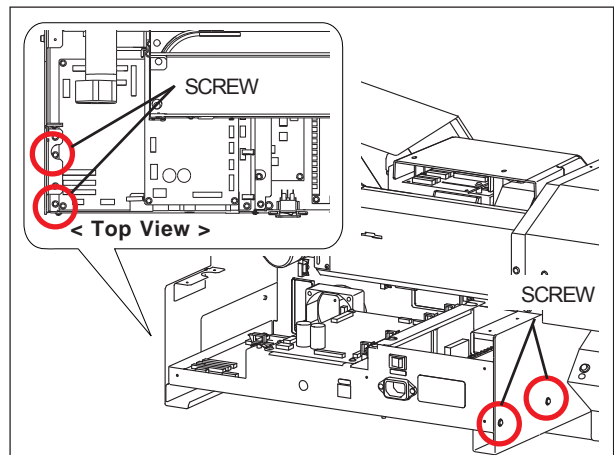

- Connect all the cables to the SW Power Supply.

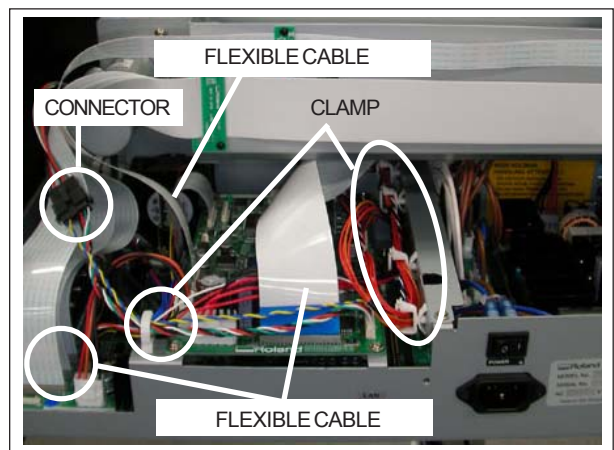

3-10 BATTERY REPLACEMENT

CAUTION

Danger of explosion if battery is incorrectly replaced.

Replace only with the same or equivalent type recommended by the manufacturer.

Dispose of used batteries according to the manufacturer's instructions.

⚠ ATTENTION

Il y a danger d'explosion s'il y a remplacement incorrect de la batterie.

Remplacer uniquement avec une batterie du même type ou d'un type équivalent recommandé par le constructeur.

Mettre au rebut les batteries usagées conformément aux instructions du fabricant.

⚠ ADVARSEL!

Lithiumbatteri - Eksplosionsfare ved fejlagtig handling.

Udskiftning må kun ske med batteri af samme fabrikat og type.

Levér det brugte batteri tilbage til laveranøren.

⚠ WARNING



Do not recharge, short-circuit, disassembly the lithium battery, nor put it into fire.

It may cause heat, explosion and fire.



Put tape around the lithium battery for insulation for disposal or preservation.

It may cause heat, explosion and fire.

- 1 Turn off the sub power, and then turn off the main power.
Remove the Chassis cover.

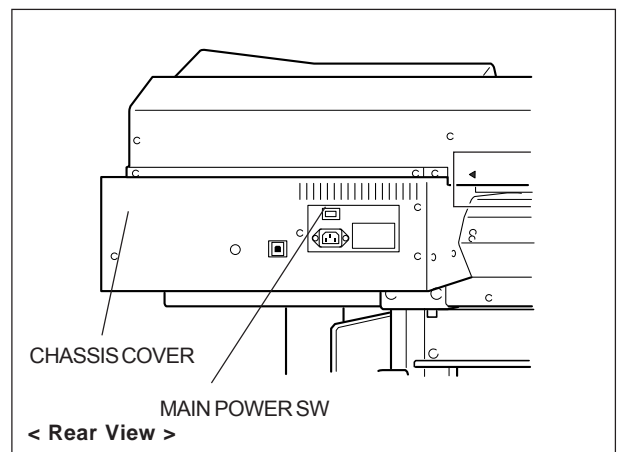

- 2** Remove the battery on the Main Board by pushing it down and tilting towards right.

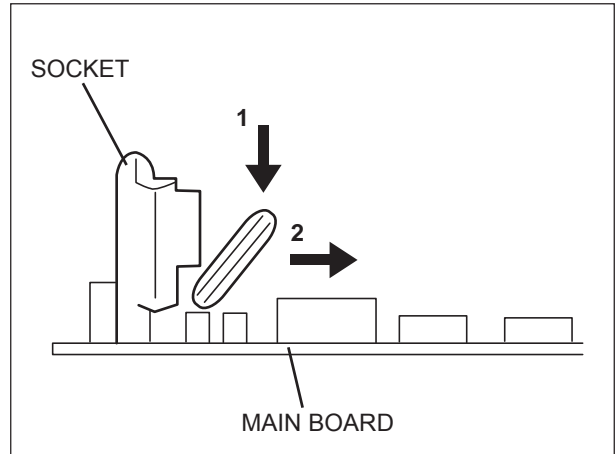

- 3** Replace the battery with new one.



Be careful with the direction of the battery.

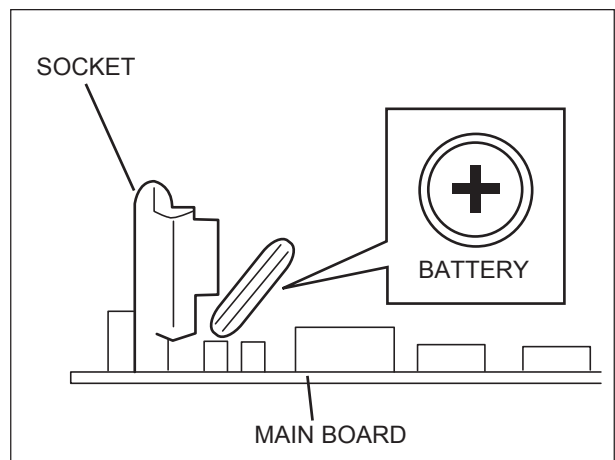

- 4** Turn on the main power, then turn on the sub power while pressing the left, right and down keys to enter the Service Mode.

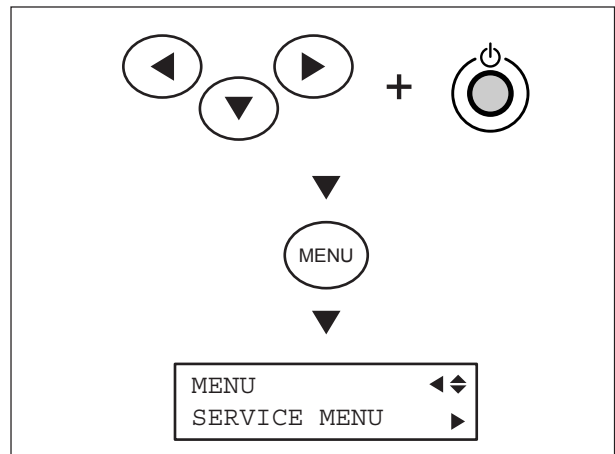

- 5** Select [SUB MENU] > [CLOCK] > [TIME], and set the time and press [ENTER] key.



The display of [B] which shows a battery exhaustion disappears by this step.

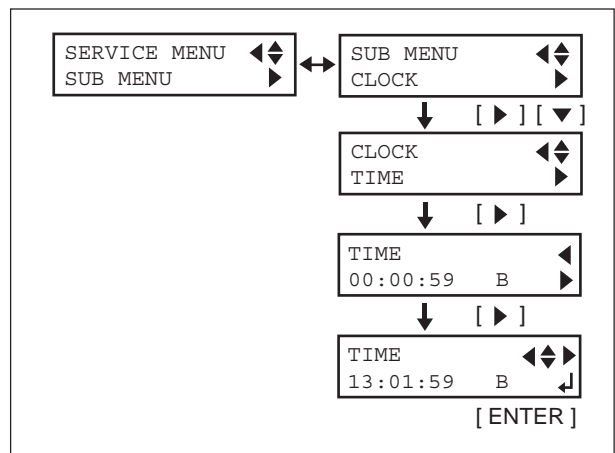

- 6 Select [SUB MENU] > [CLOCK] > [DATE], and set the date and press [ENTER] key.

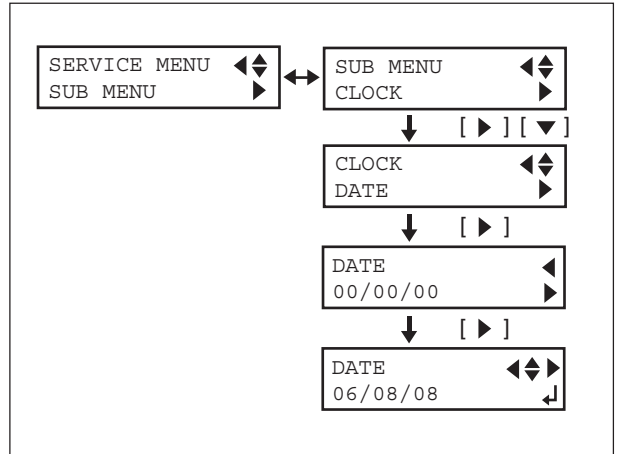

- 7 Turn off the sub power, and then turn off the main power.
Fix the Chassis Cover.

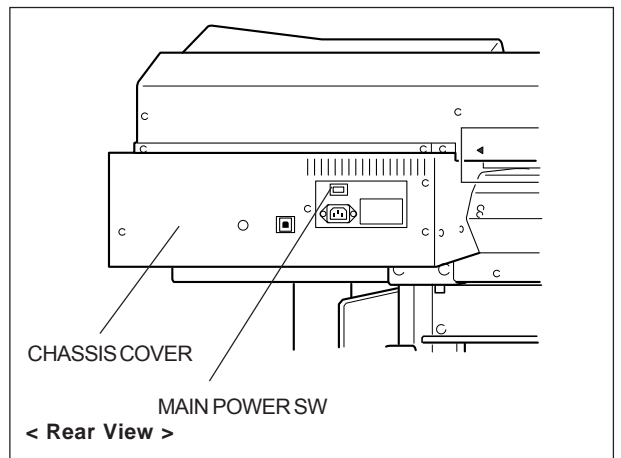

- 8 Dispose of the battery.

3-11 CARRIAGE BELT REPLACEMENT

!!!IMPORTANT!!!

When replacing the Carriage Belt, make sure to connect the new belt to the current belt, and pass the new belt at the same time as removing the current belt.

There is a possibility that the new belt cannot be fixed without connecting the new belt to the current belt.

- 1 Turn off the sub power, and then turn off the main power.

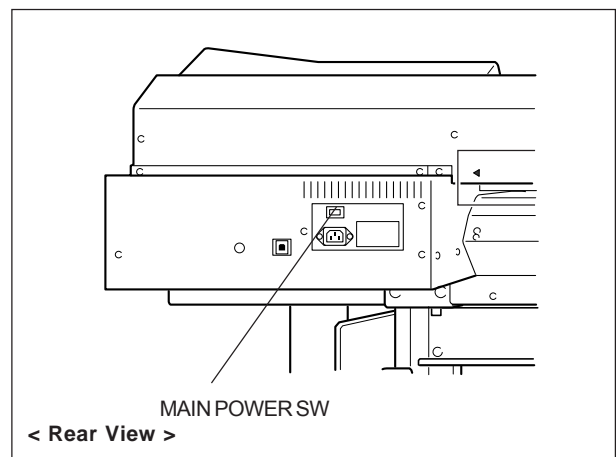

- 2 Remove the following covers.

I/S Cover
Maintenance Cover
Left Side Cover
Front Cover
Top Cover
Right Top Cover

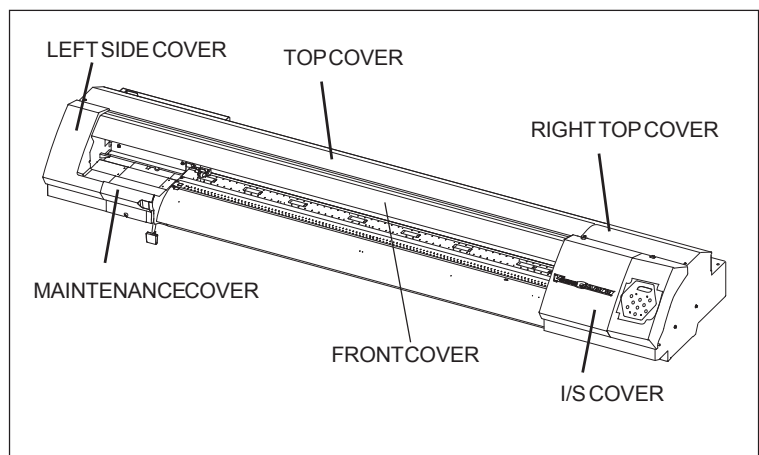

- 3 Separate the Tool Carriage from the Head Carriage.

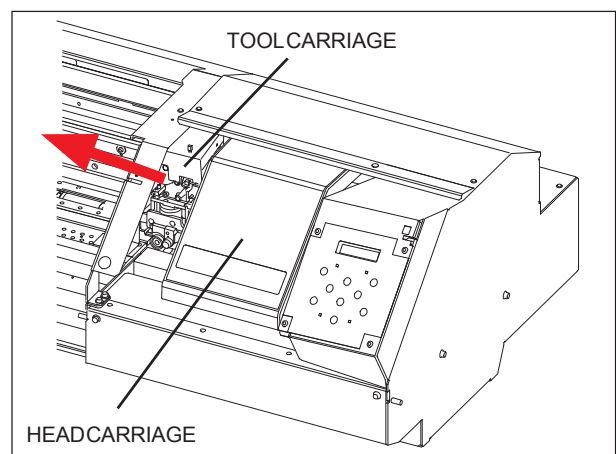

4 Remove the Tool Carriage Cover.

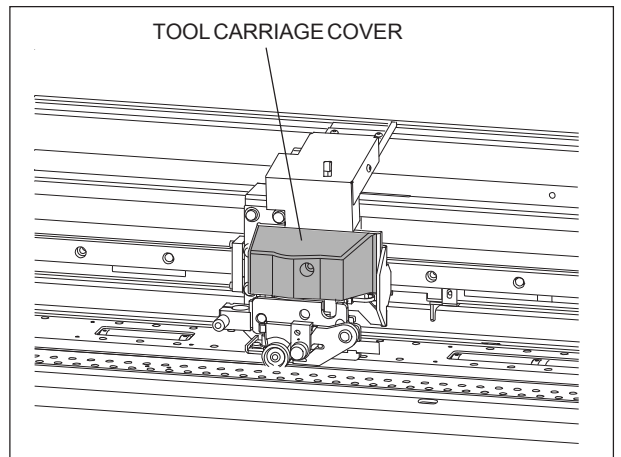

5 Remove the 4 rivets as shown in the figure to remove the Tool Carriage Board Cover.

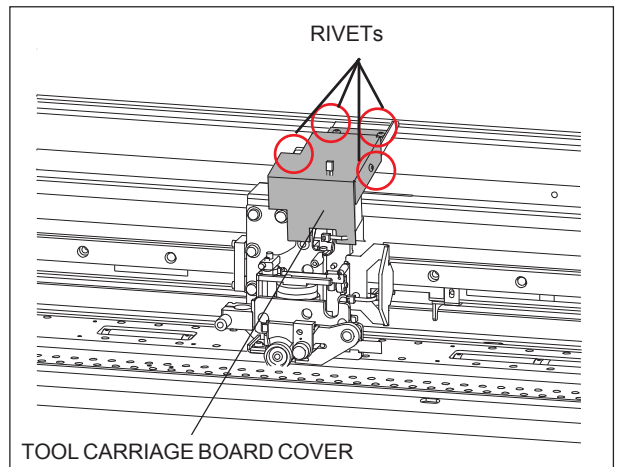

6 Disconnect the Crop Mark Sensor, Pinch Roller Sensor and Solenoid wirings.

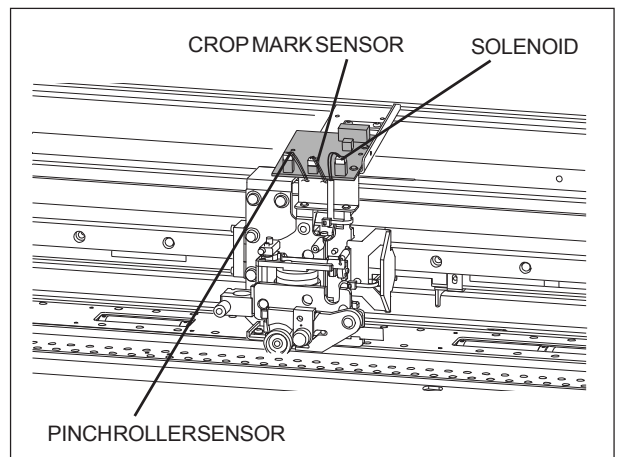

7 Remove the 2 screws fixing the Tool Carriage Board.

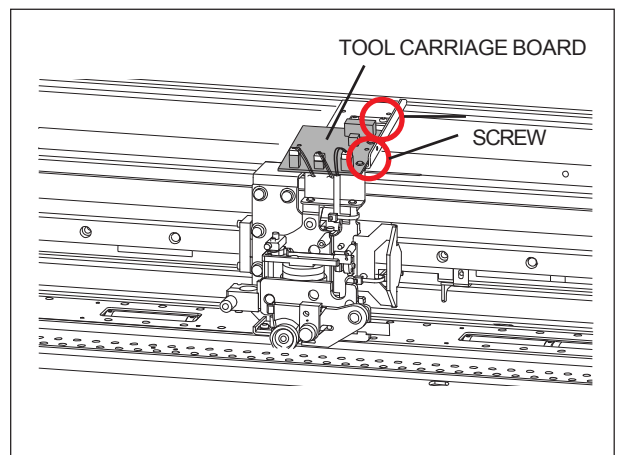

- 8** Remove the 2 screws to remove the Tool Carriage Board Stay from the Tool Carriage Assy.

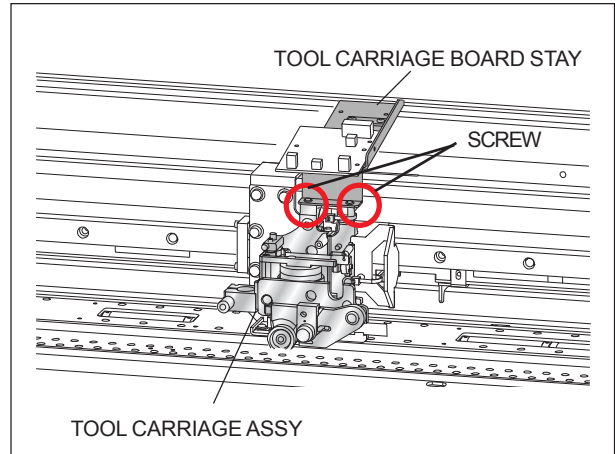

- 9** Loosen the 2 fixingscrews as shown in the figure. And loosen the Adjustment Screw.

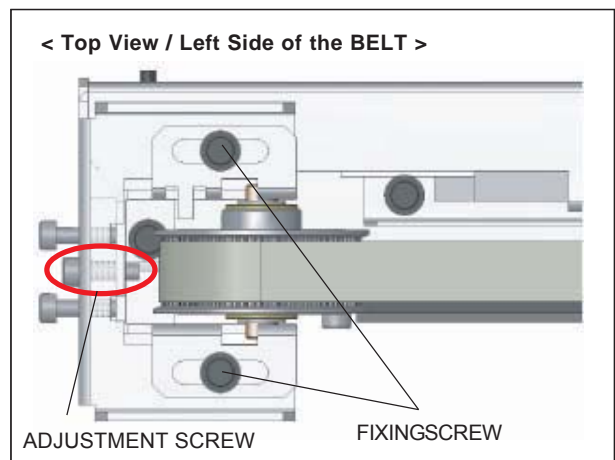

- 10** Loosen the 4 screws as shown in the figure.

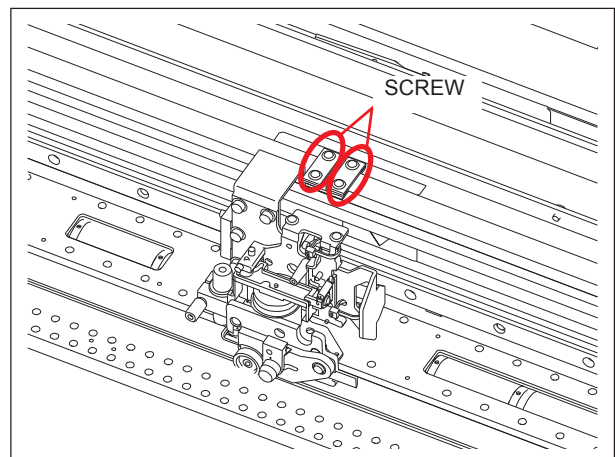

- 11** Remove the Carriage Belt from the plate, and connect the new belt with the scotch tape.

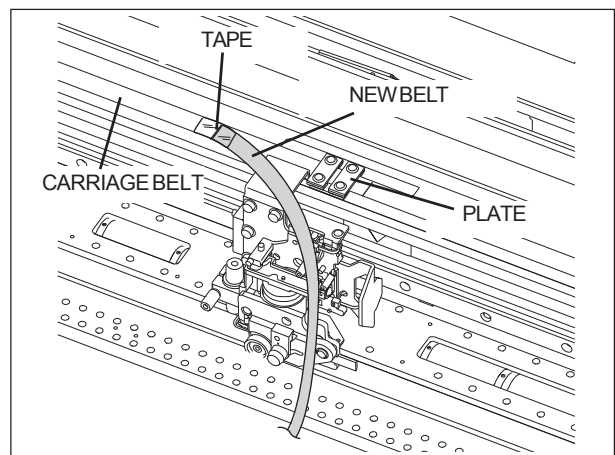

12 Slowly pull the belt end which is not connected the new belt until the new one reaches to the Belt Stay.



Check that the belt is not twisted.



Apply adequate quantity of grease (P/# : 39008297 FLOIL G 902 14KG) to pulleys.

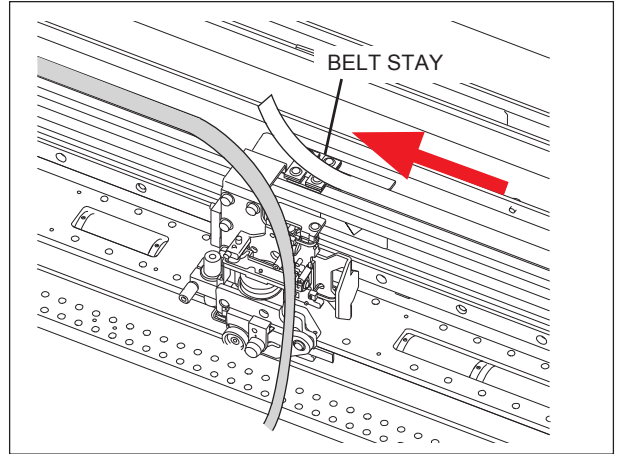
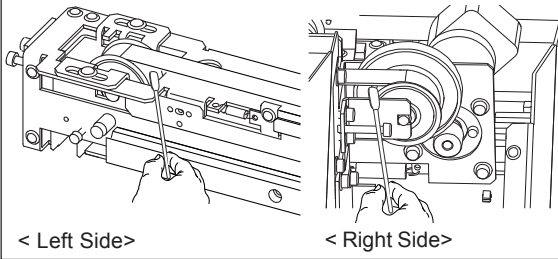

13 Tighten the screws as shown in the figure to fix both ends of the Carriage Belt to the Belt Holder with the plastic plate and metal plate.



When fixing the Carriage Belt, make sure the ends of the Carriage Belt are not overlapped.



Be careful with the fixing direction of the plastic plate and the fixing order of the plates.

< Cross-section diagram >

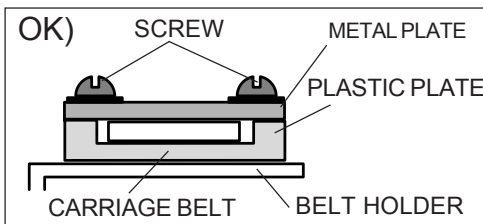

< Cross-section diagram >

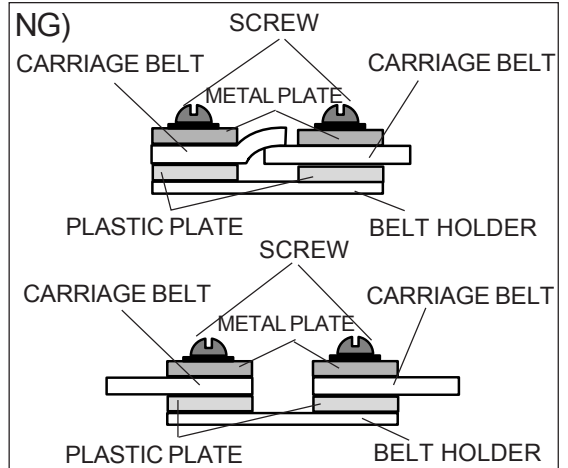
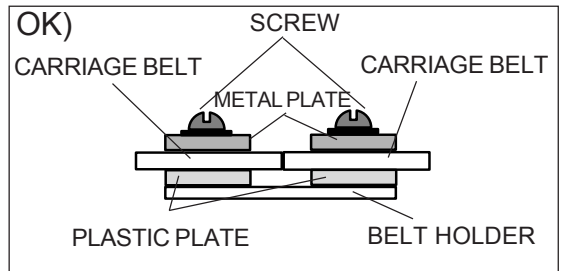

14 Tighten the Adjustment Screw to have tension on the belt. And tighten the 2 Fixingscrews as shown in the figure.



Do not tighten the Adjustment Screw tight.

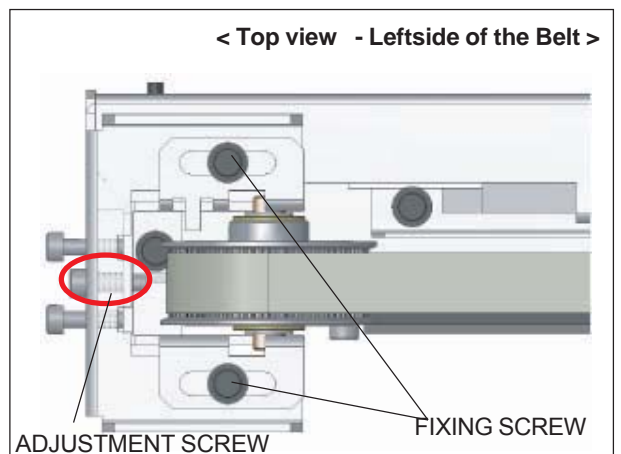

- 15** Fix the Tool Carriage Assy to the Tool Carriage Board Stay.

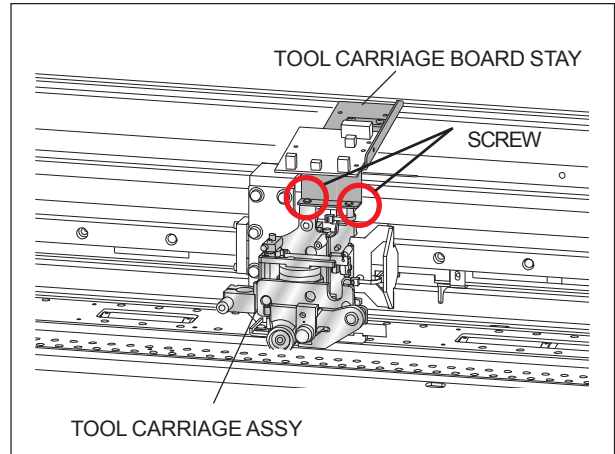

- 16** Fix the Tool Carriage Board with the 2 screws as shown in the figure.

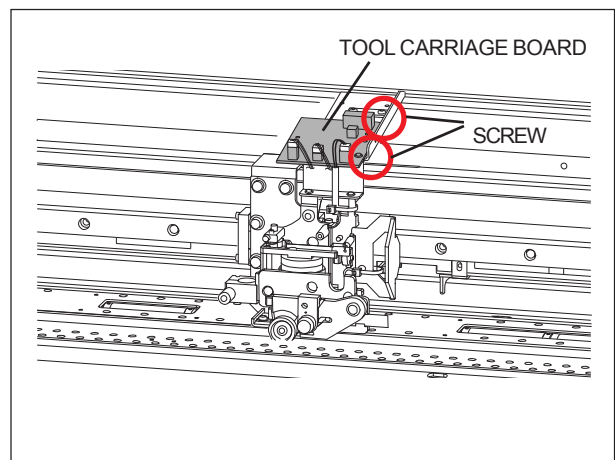

- 17** Connect the Crop Mark Sensor, Pinch Roller Sensor, and Solenoid wirings.

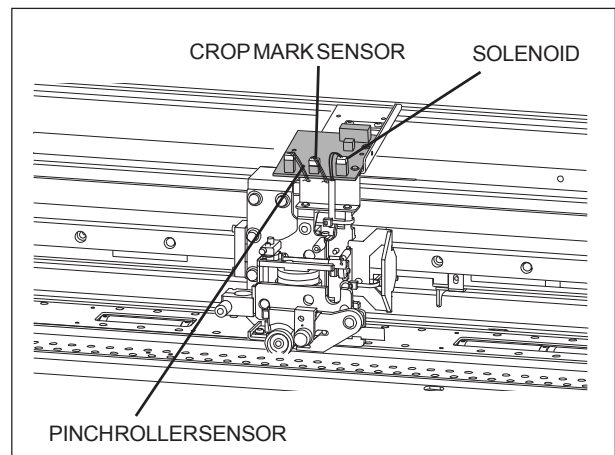

- 18** Move the Head Carriage in a whole width of the Guide Rail several times to remove the slack in the Carriage Belt. Then, carry out the following adjustments.

1. [4-14 BELT TENSION ADJUSTMENT]
2. [4-15 BELT POSITION ADJUSTMENT]
3. [4-5 LIMIT POSITION & CUT DOWN POSITION INITIALIZE]
4. [4-7 FLUSHING POSITION ADJUSTMENT]
5. CUTTING QUALITY CHECK

Revised 1

3-12 ENCODER SCALE REPLACEMENT

1 Remove the following covers.

- I/S Cover
- Maintenance Cover
- Left Side Cover
- Front Cover
- Top Cover

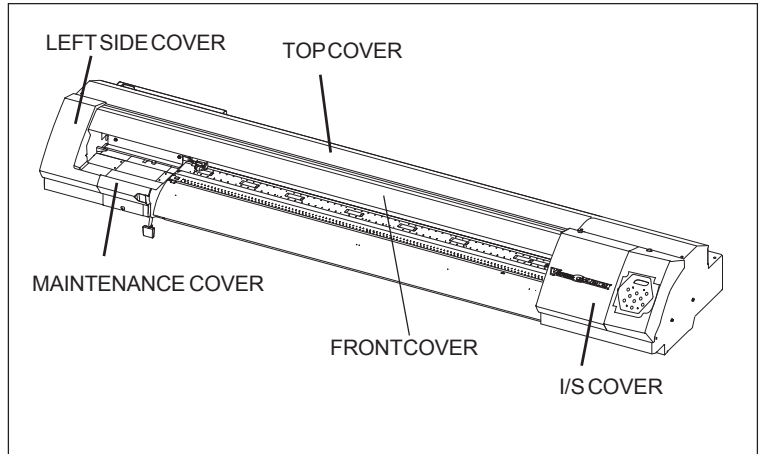

2 Move the Head Carriage slowly leftwards.

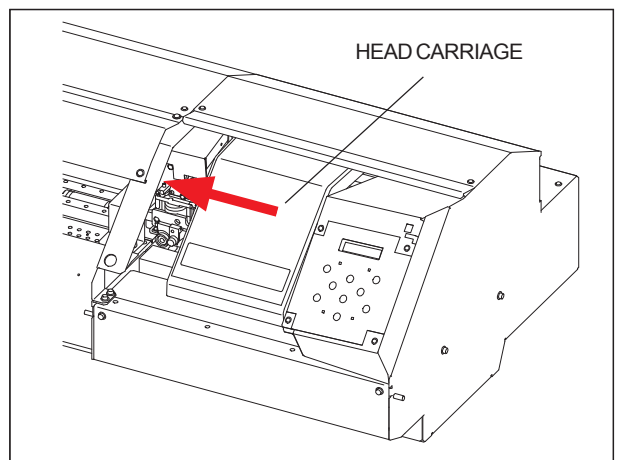

3 Remove the Encoder Scale by removing the plate fixing the Encoder Scale at its right end and the spring on its left end.

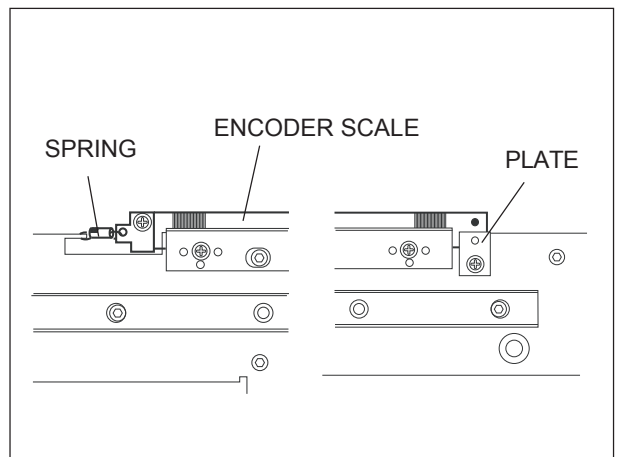

4 Remove the Spring Plate from the Encoder Scale and fix it to the new Encoder Scale where there is no black dot written on it.

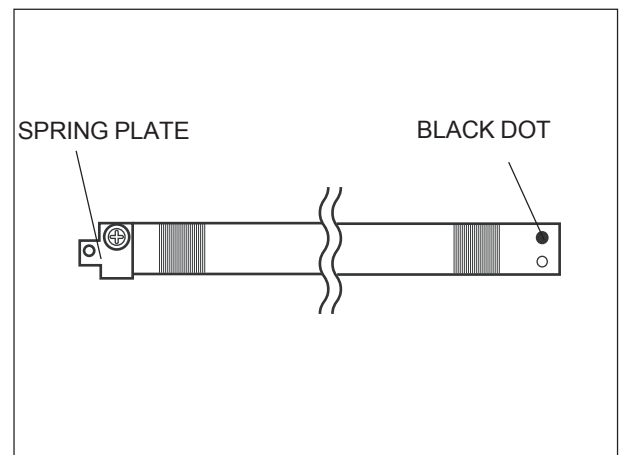

Make sure not to scratch or put grease on the Encoder Scale when fixing it.
Do not touch the surface of the Encoder Scale.

5 Put the Encoder Scale in between the Encoder Plate and the Guide Rail.

Then, fix the right end with the plate and hook up the spring on the left end.

Make sure that the Encoder Scale is in place.



Do not loosen or tighten the screws fixing the Encoder Plate.

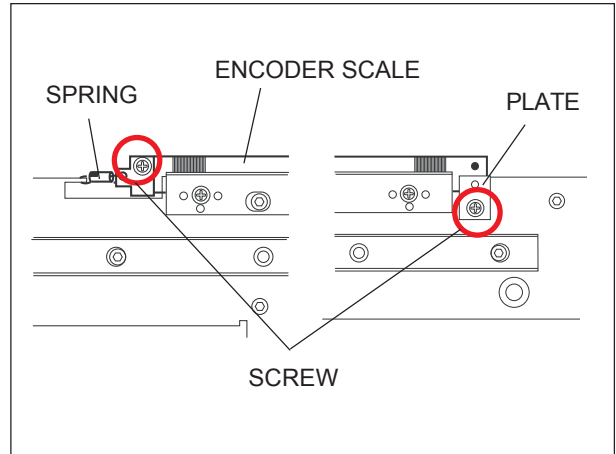

6 Move the Head Carriage in a whole width of the machine. Make sure that the Encoder Scale doesn't make contact with the Encoder Module and also Encoder Scale is between the slit of the Encoder Module.

Carry out the [4-6 LINEAR ENCODER SETUP].

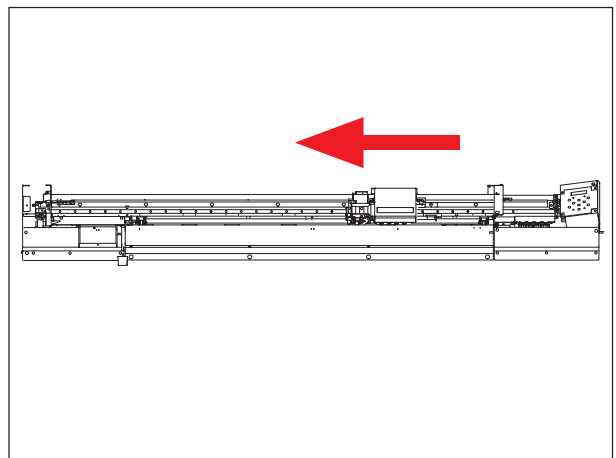

3-13 GRIT ENCODER REPLACEMENT

- 1** Turn off the sub power, and then turn off the main power.

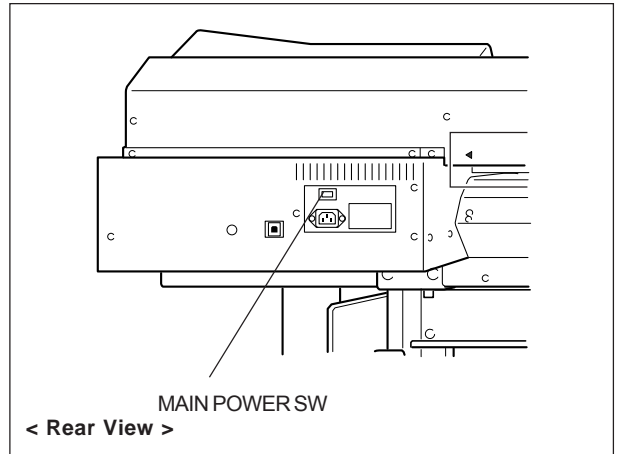

- 2** Remove the following covers.

Maintenance Cover
Left Side Cover
Left Cover

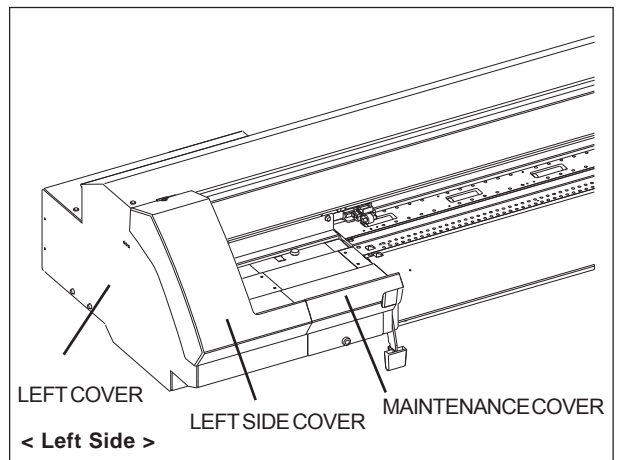

- 3** Remove the screw as shown in the figure to remove the Grit Encoder Board together with the stay.

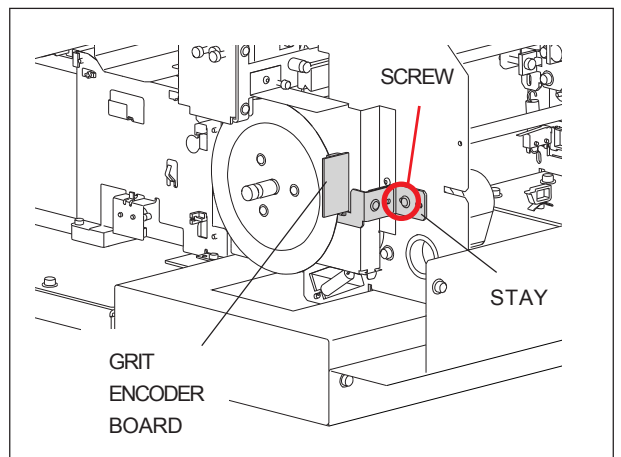

- 4** Remove the 3 screws as shown in the figure to remove Grit Encoder Stopper.

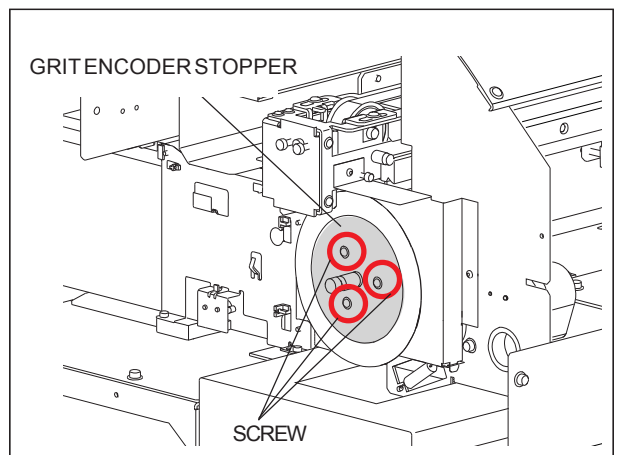

5 Replace with the new Grit Encoder.



The both sides of the Grit Encoder is the same.
When fixing the Grit Encoder, make sure not to scratch or leave any fingerprints on the Grit Encoder.

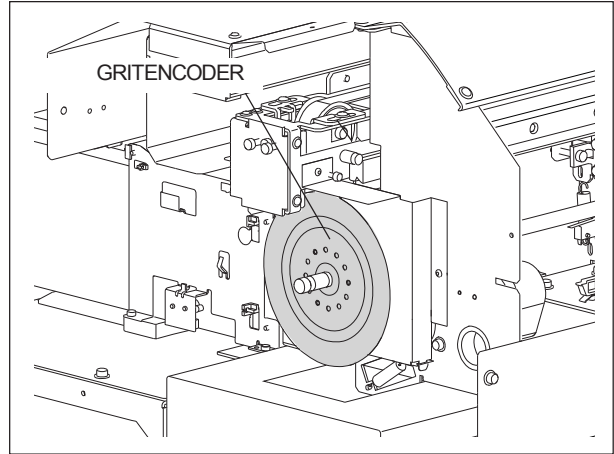

6 Fix the Grit Encoder Stopper with the 3 screws as shown in the figure by holding the Shaft.

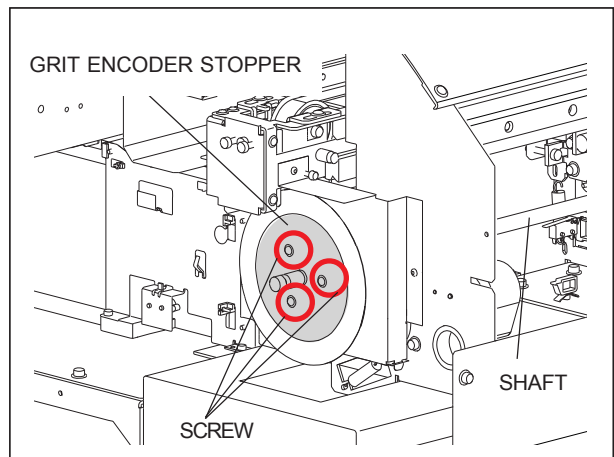

7 Fix the Grit Encoder Board together with the stay so that the Grit Encoder is in between the sensor.



Adjust the position of the sensor so that the clearance with the Grit Encoder is around 1mm.

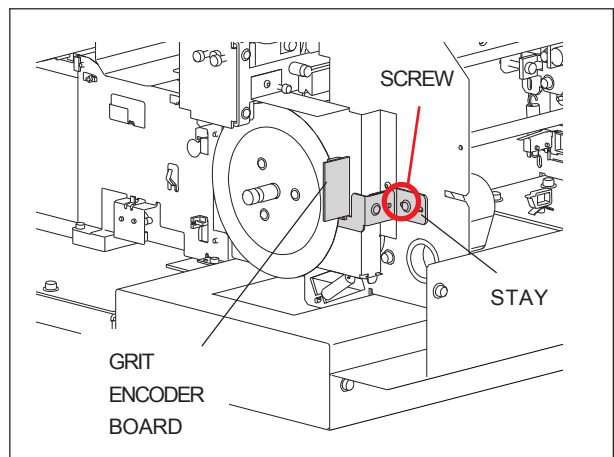
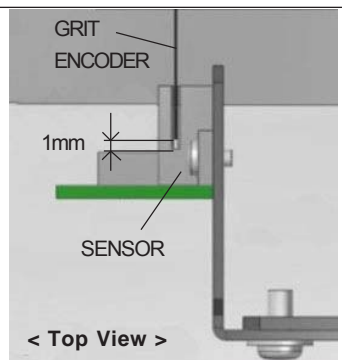

Revised 1

8 Rotate the Shaft by Flange to check that the Grit encoder does not touch the sensor.



In case that the Grit Encoder touches the sensor, loosen the screw as shown in the figure to adjust the sensor by moving it right and left.

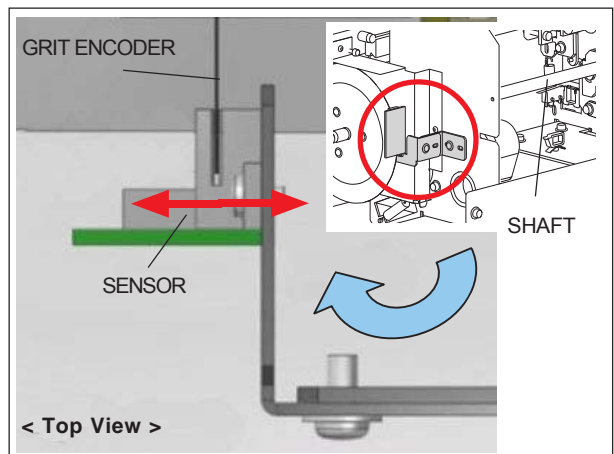
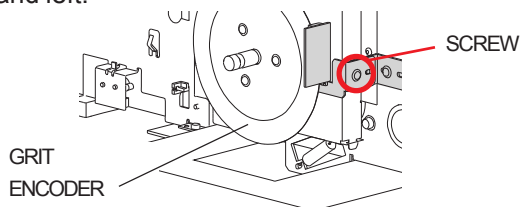

- 9** Perform the SERVO LOCK CHECK.
After turning on the main power, turn on the sub power while pressing the left, right and down keys to enter the Service Mode.

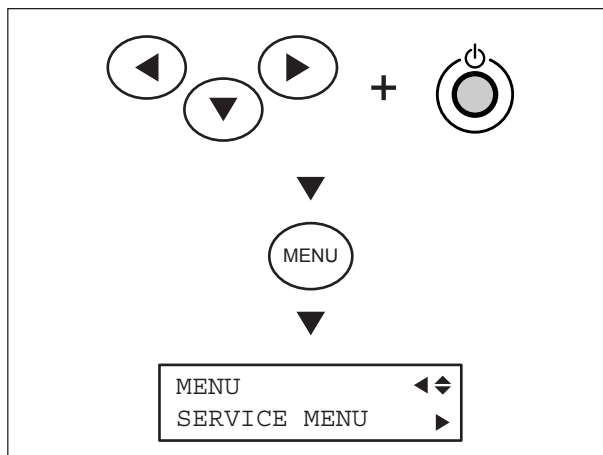

- 10** Check the GRIT ENCODER.
Go back to the [MOTOR MENU], and select [G-ENC. CHECK] and press the [ENTER] key. Make sure the Grit Encoder functions correctly by confirming the display shows [G-ENC. CHECK COMPLETED].

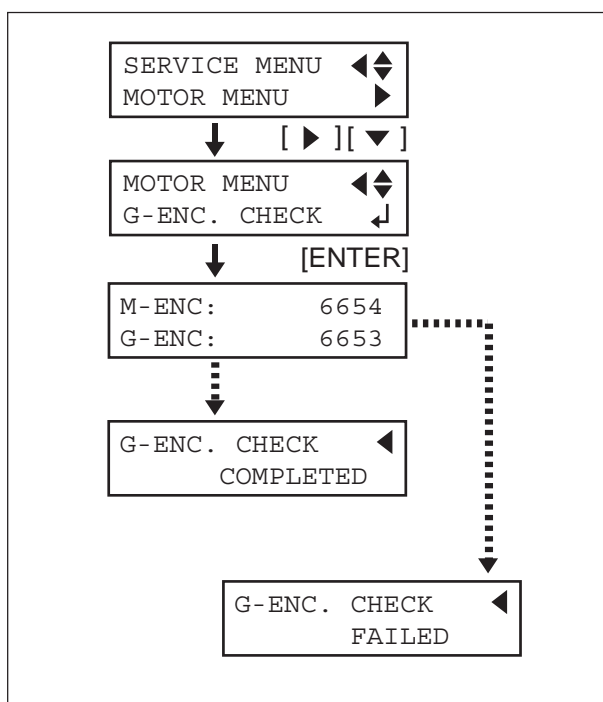

In case that [G-ENC. CHECK FAILED] appears, check the followings.

1. Grit Encoder is fixed correctly.
2. Feed Motor is fixed correctly.
3. There is no scratches or finger prints.

- 11** Fix the following covers.

MaintenanceCover
Left Side Cover
LeftCover

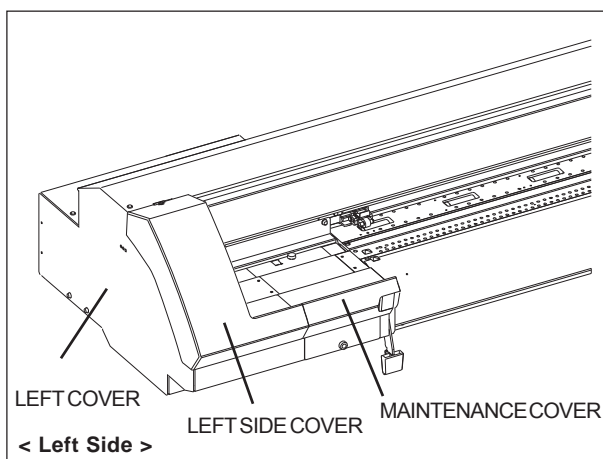

3-14 PINCH ROLLER REPLACEMENT

- 1 Conical type is used on both left & right Pinch Rollers and flat type is used for the Middle Pinch Rollers.



Red marking is done on the outer side of left & right Pinch Rollers.
There is no marking on the middle Pinch Rollers.

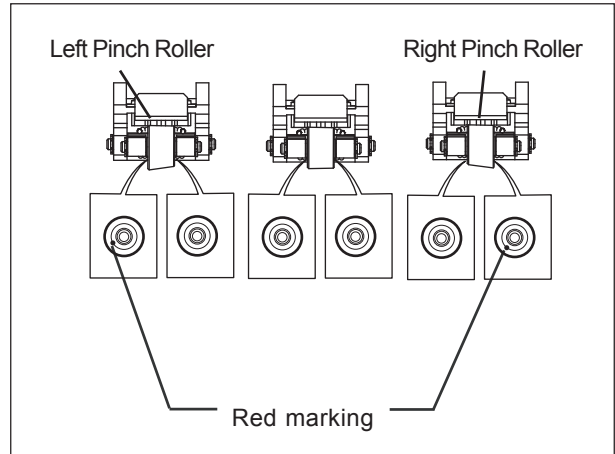

- 2 Remove the E Ring on one side of the Pinch Roller and pull out the Shaft.



Make sure not to lose the washers which are fixed at both sides of the Pinch Roller.

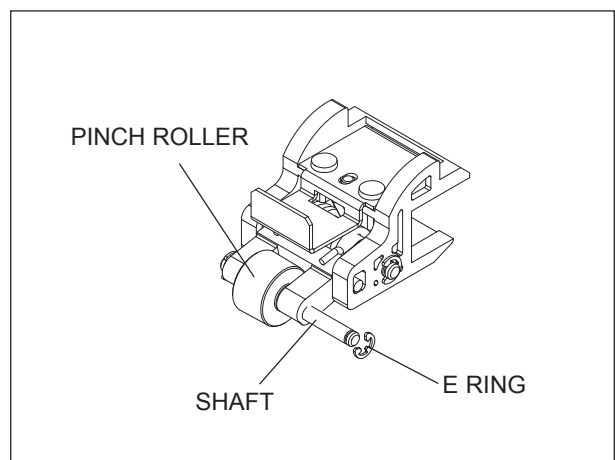

- 3 Put the new Pinch Roller with washers and insert the Shaft into the Pinch Roller.

Fixing operation becomes easy when you put the washers to the Pinch Roller with grease.

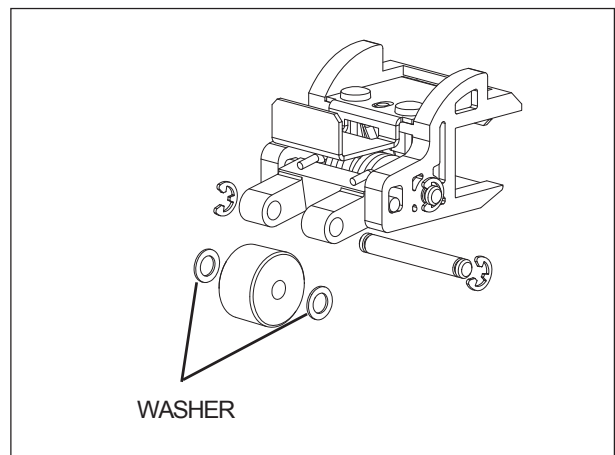

- 4 Fix the E Ring and check that the Pinch Roller rotates smoothly.

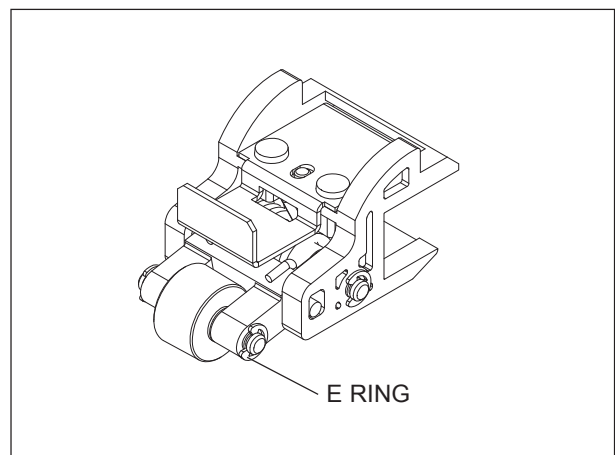

3-15 CUTTER PROTECTION REPLACEMENT

- 1 Remove the Cutter Protection.

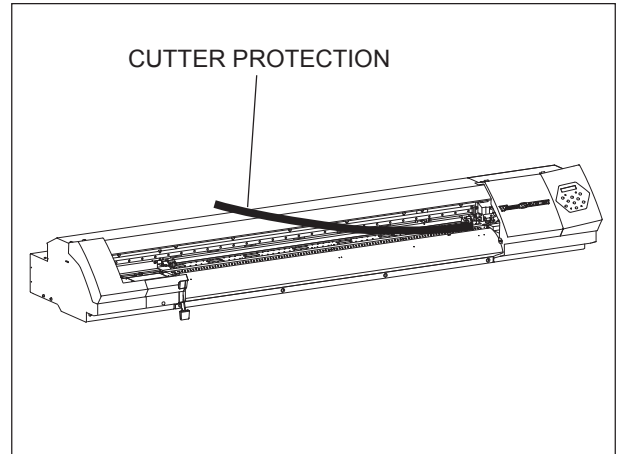

- 2 Wipe the adhesive on the Bed with alcohol.

- 3 Install the Cutter Protection from 1mm from right edge of the Bed.

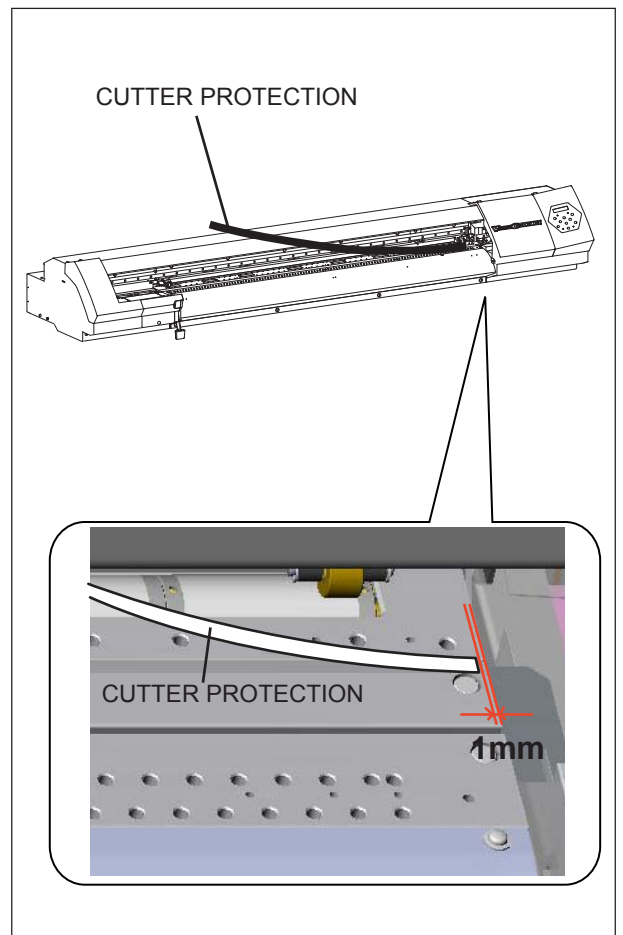

- 4 Make sure that the Cutter Protection is not bumpy.

3-16 HOLDER CABLE SHEET REPLACEMENT Revised 2

- 1** Turn on the sub power while pressing the left, right and down keys to enter the Service Mode.

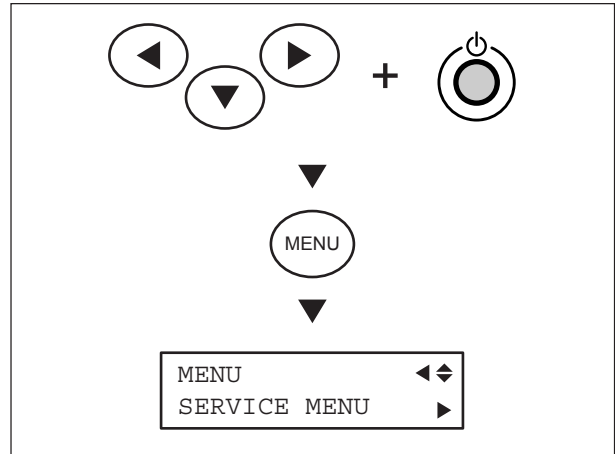

- 2** Select [SERVICE MENU] > [SUB MENU] > [PUMP UP], and remove ink by following the sequence.

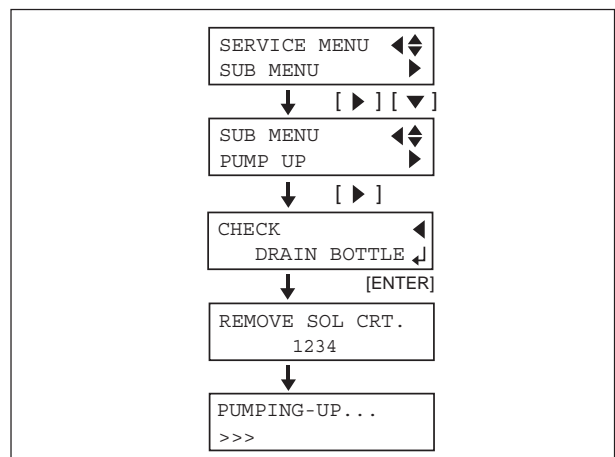

- 3** Turn off the sub power, and then turn off the main power.

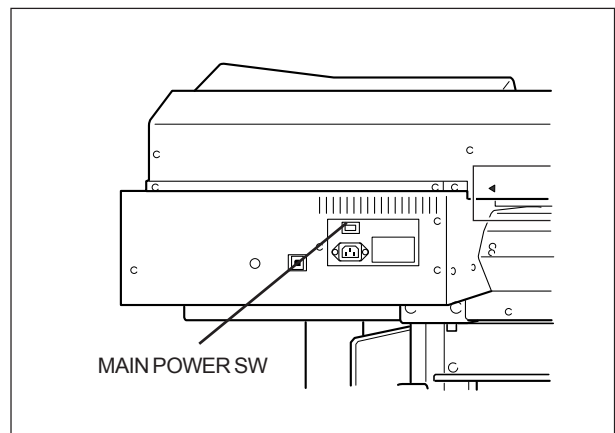

- 4** Remove the following covers.

- I/S Cover
- MaintenanceCover
- Left Side Cover
- Front Cover
- TopCover
- Right Top Cover

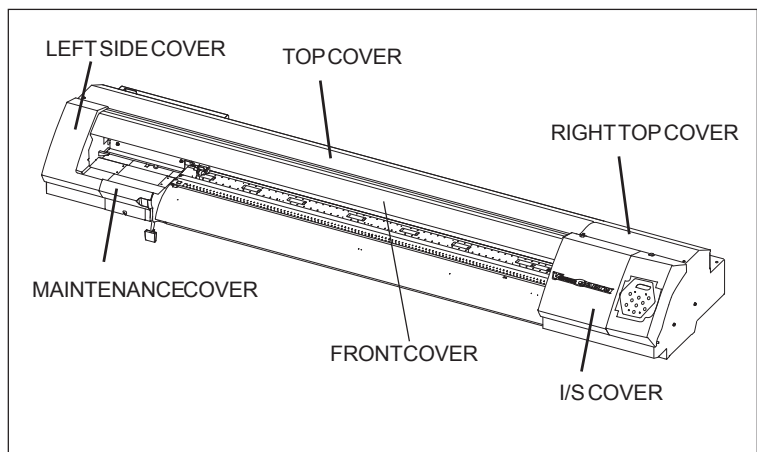

5 Remove the Cut Cable Guide.

< VP-300 >

- 1) Remove the 3 screws to remove the Cut Cable Guide.

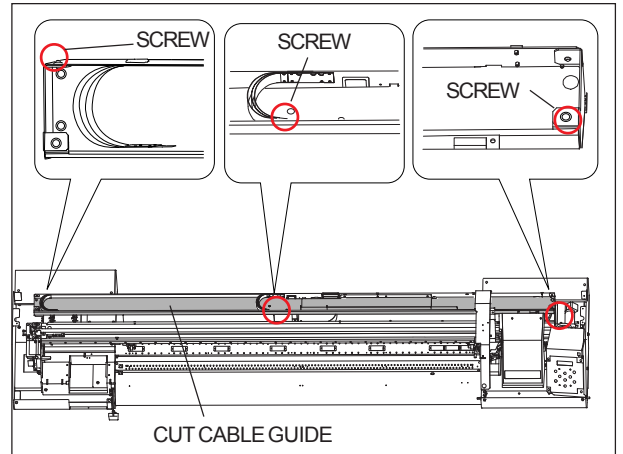

< VP-540 >

- 1) Remove the 3 screws to remove the Cable Support.



Pull the flexible cable to access the screw.

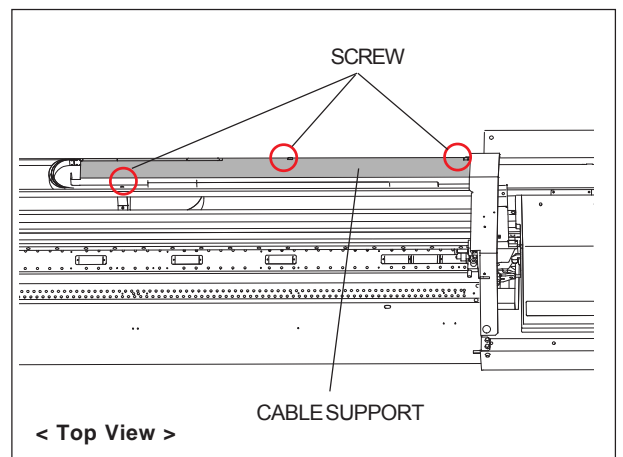
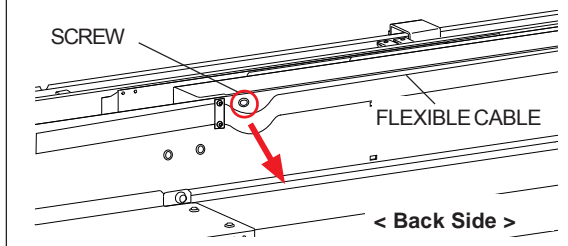

- 2) Remove the 3 screws to remove the Cut Cable Guide.

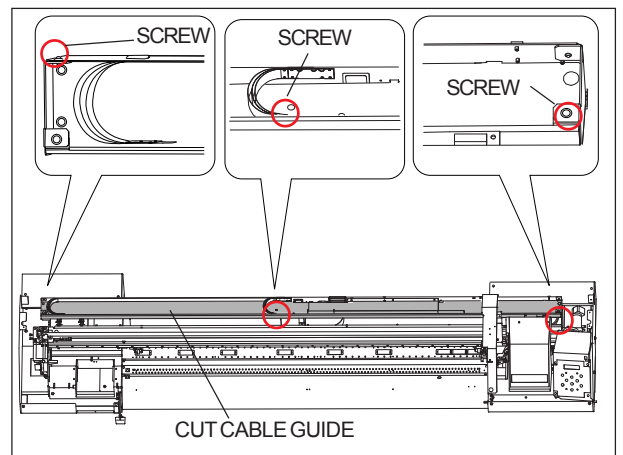

6 Remove the Carriage Cover.

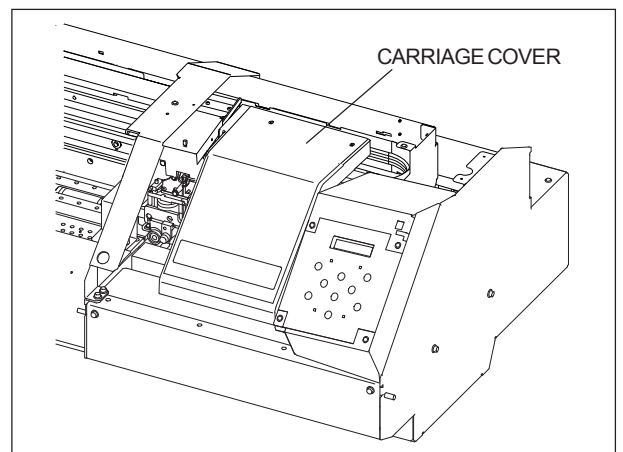

- 7** Disconnect the ink tubes from the Y tube joints, and put the scotch tape at the tip of the ink tube to prevent the ink from coming out. And remove them from the Clamps.

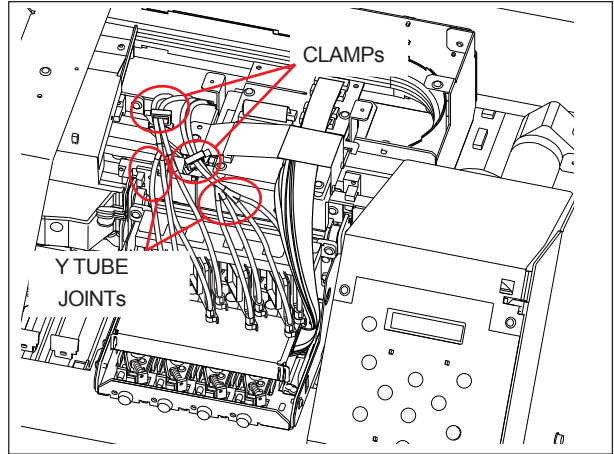

- 8** Open the clamp and disconnect the 3 flexible cables from the Carriage Board.

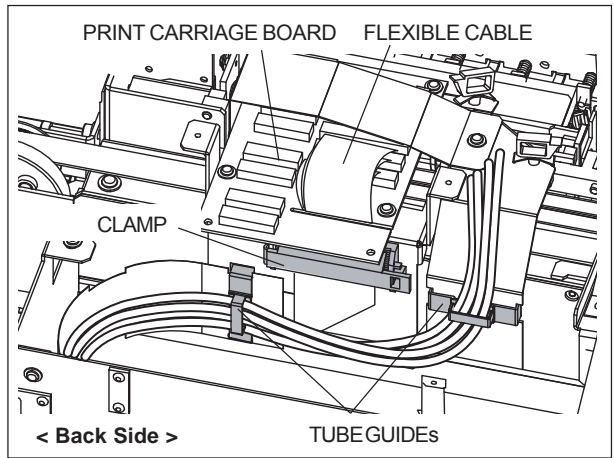

- 9** Remove the Cable Holders and Holder Cable Sheets from the Tube Guides leaving the flexible cables and Holder Cable Plates.

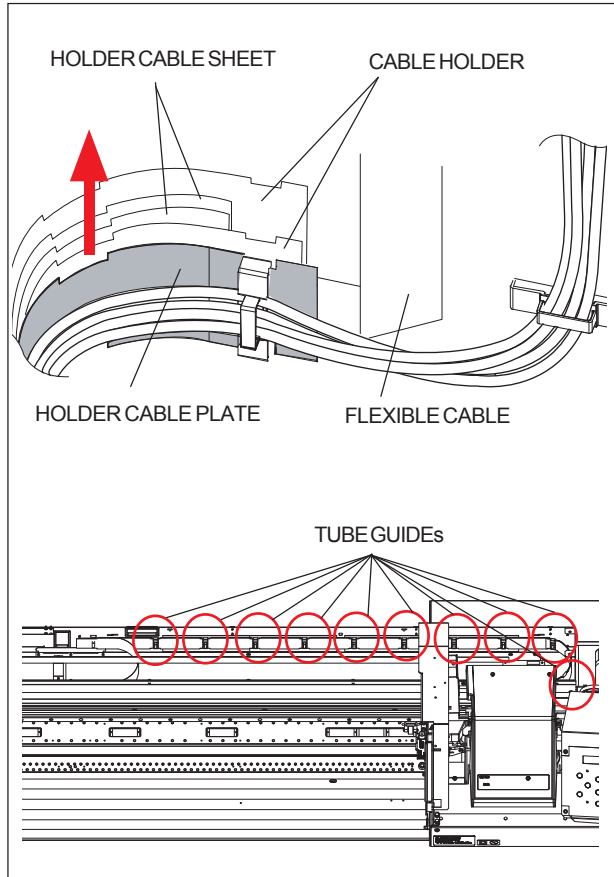

10 Replace the tube guides if they are not following tube guide.



Parts No. : 1000003293
Parts Name : GUIDE,TUBE TYPE3 VP-540

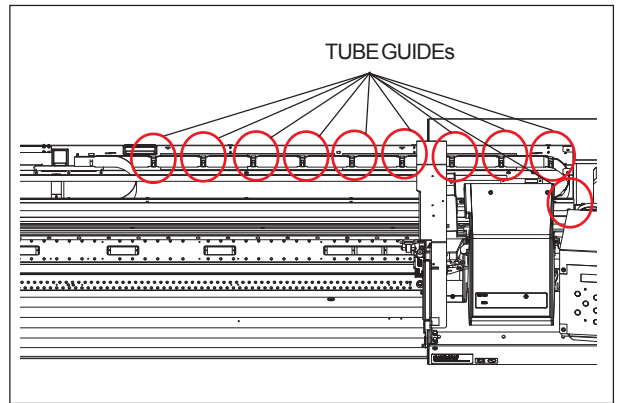

Revised 3

11 Fix the new Cable Holders and Holder Cable Sheets to the Tube Guides with reference to the following figures.



Make sure that the cables fit in the grooves of the tube guides.

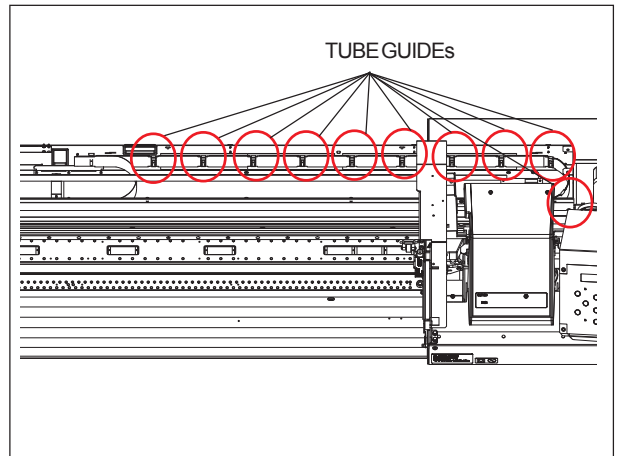
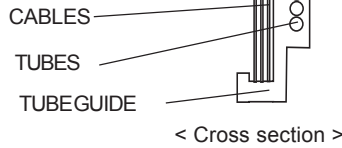

Be careful that the fixing order.

< Fixing Position >

CABLE HOLDER

HOLDER CABLE SHEET x2

FLEXIBLE CABLE x3

CABLE HOLDER

HOLDER CABLE PLATE

TUBEGUIDE

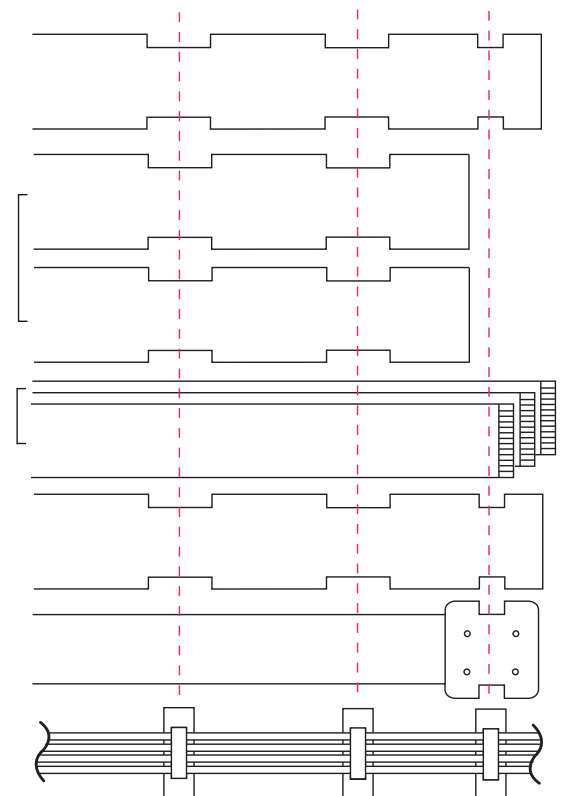



Make sure that the fixing direction of the Holder Cable Plate is correct.

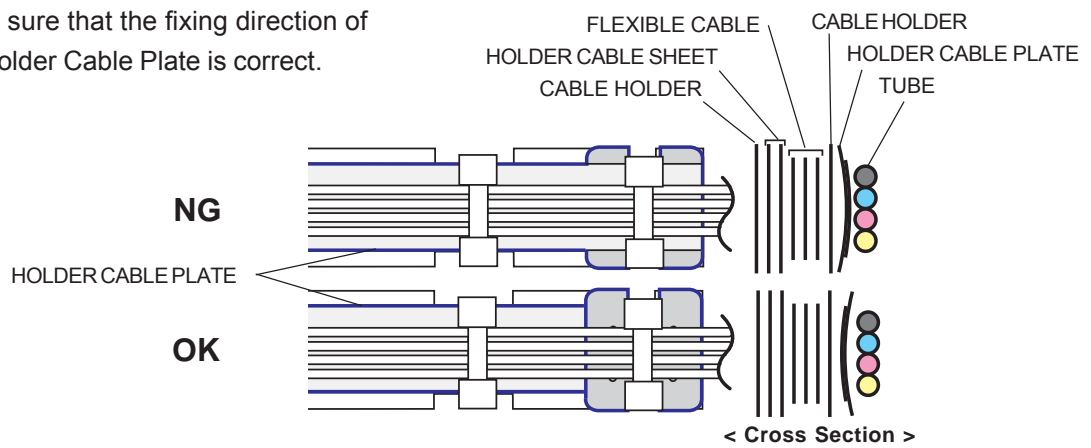

- 12** Fix the 2 Tube Guides.
Connect the flexible cables to the Carriage Board, and fix them to the clamps.



In case of replacing the tube guides, cross the tubes two by two as shown in the figure, when fixing the tubes to the tube guides.



Make sure that the tubes do not touch the plate and Cable Guide Support.

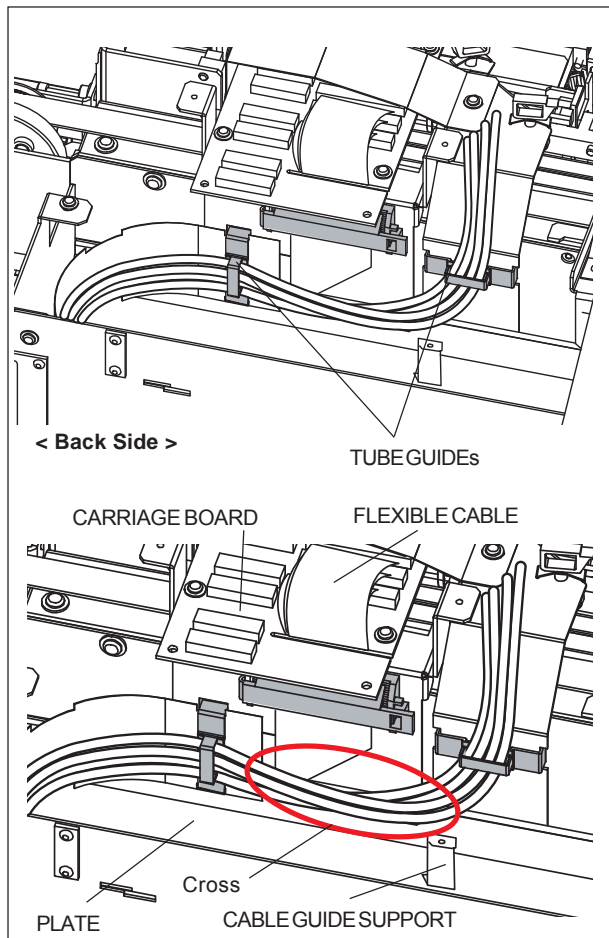

- 13** Cross the tubes two by two as shown in the figure, and fix them to the Clamps.

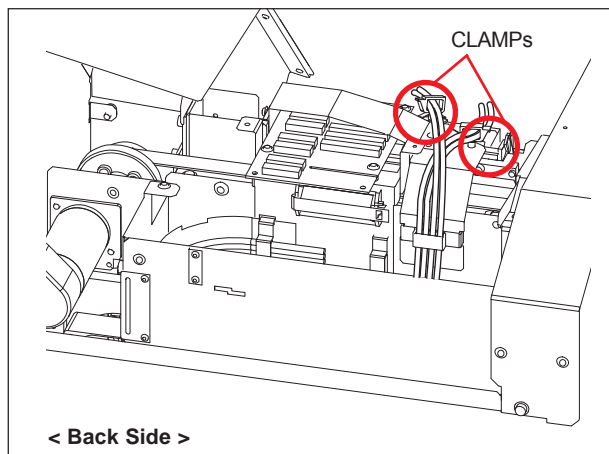

- 14** Connect the tubes to the Y tube joints.
Fix them to the Clamps.

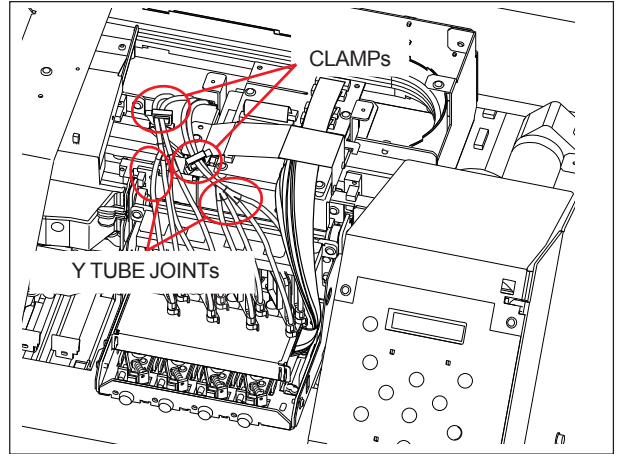

- 15** Fix the Carriage Cover.

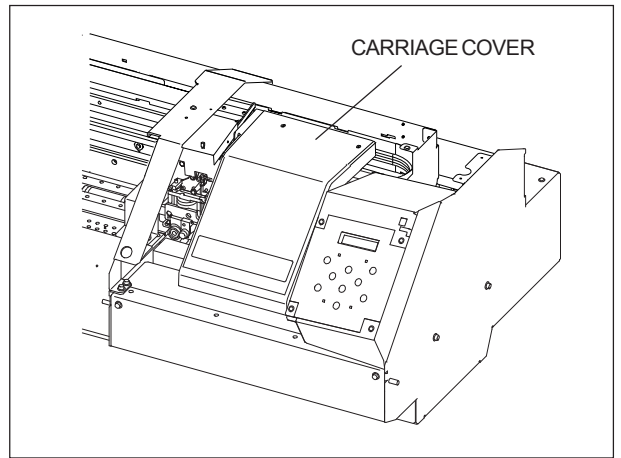

- 16** Fix the Cut Cable Guide.

< VP-300 >

- 1) Fix the Cut Cable Guide with the 3 screws as shown in the figure.

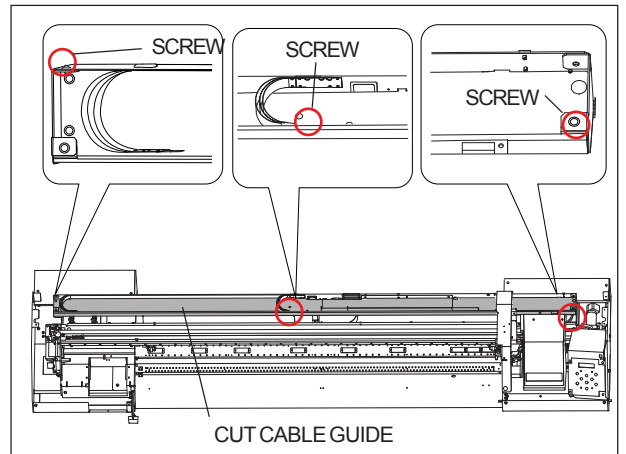

< VP-540 >

- 1) Fix the Cut Cable Guide with the 3 screws as shown in the figure.

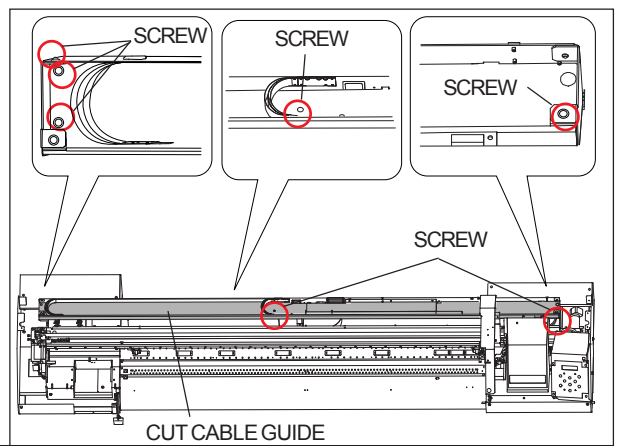

2) Fix the Cable Support with the 3 screws as shown in the figure.

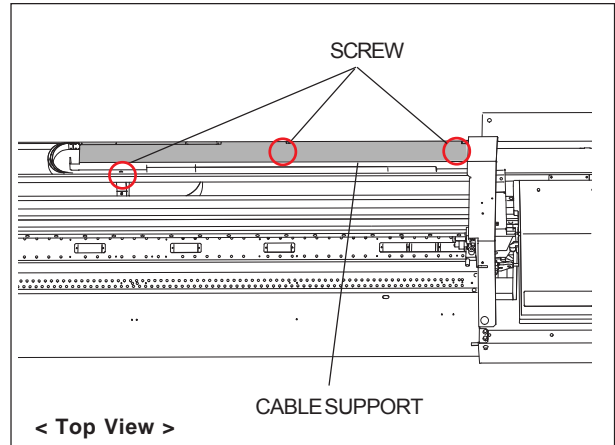

17 Move the Head Carriage in a whole width of the machine manually to make sure that there is no noise. Confirm the cable assemblies when it makes abnormal noise.

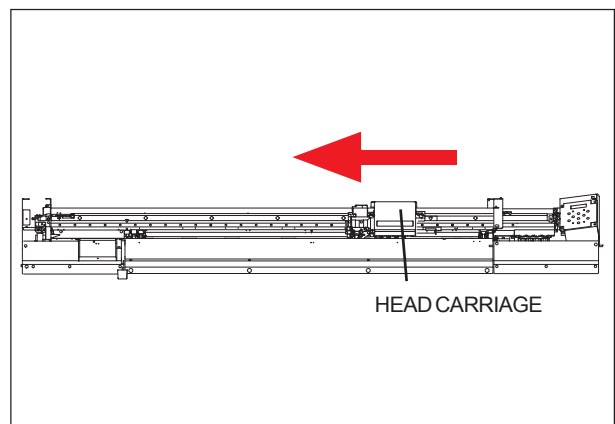

18 After turning on the main power, turn on the sub power while pressing the left, right and down keys to enter the Service Mode.

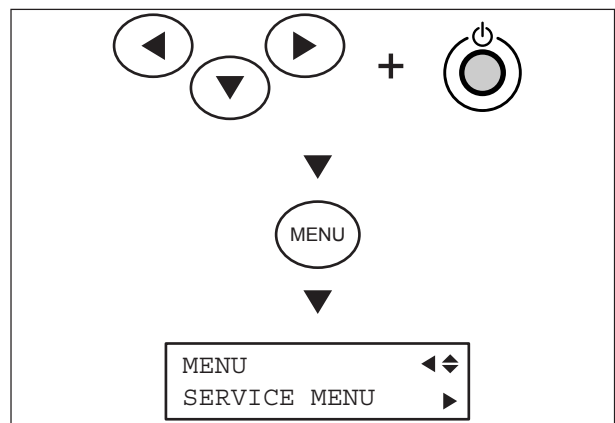

19 Select [SERVICE MENU] > [SUB MENU] > [FILL INK], and perform Ink Filling by following the sequences.

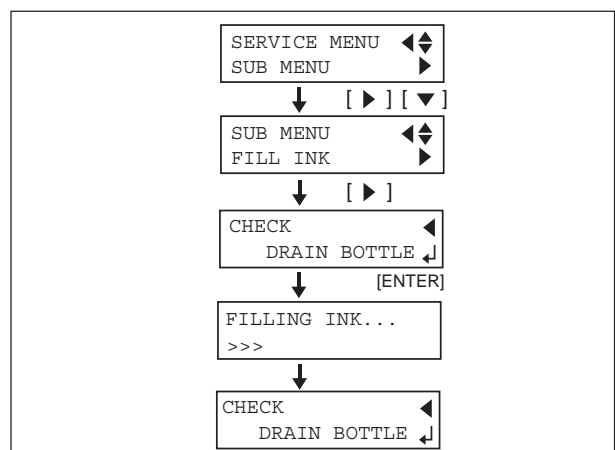

4 Adjustment

4-1 SERVICE MODE

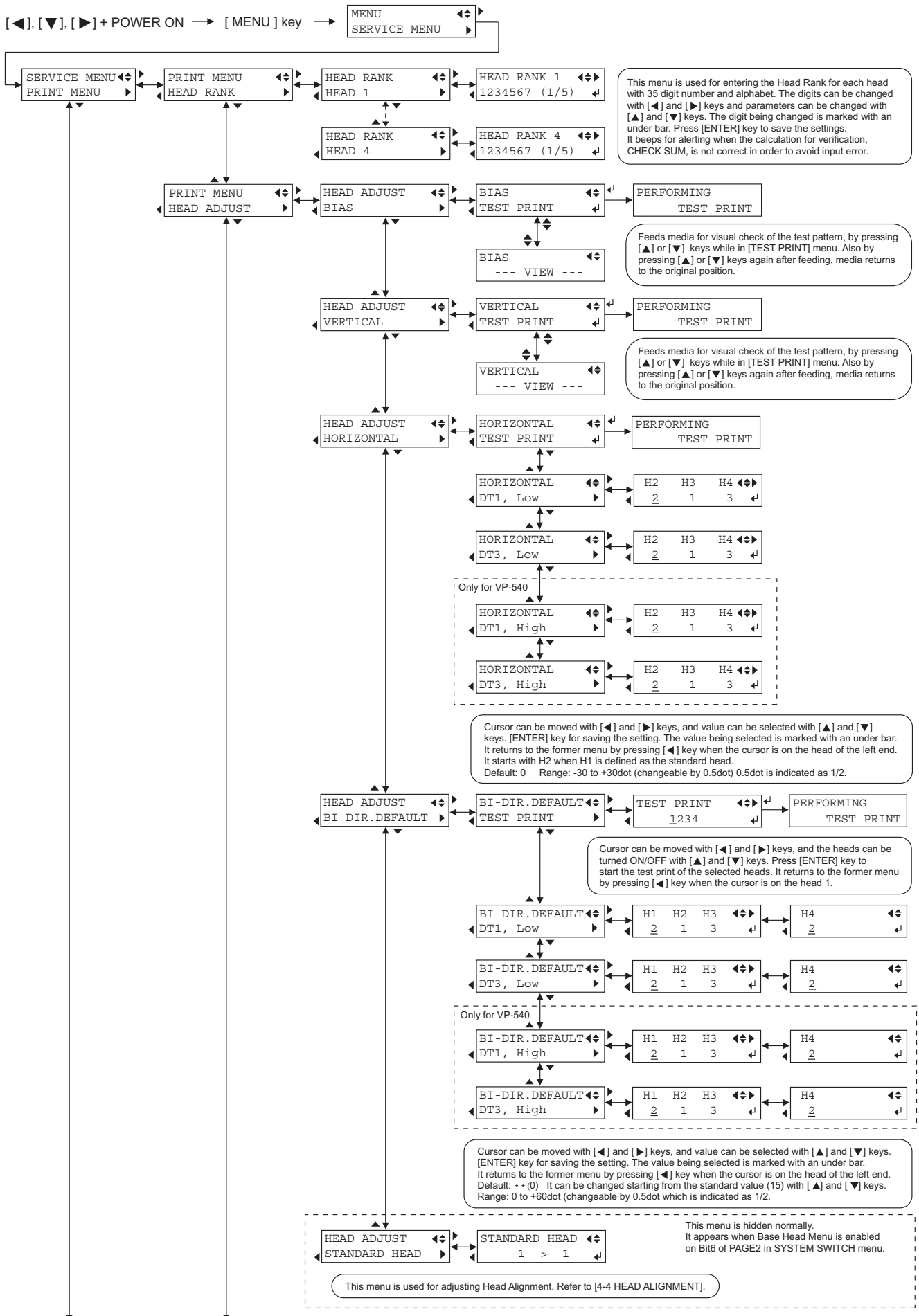

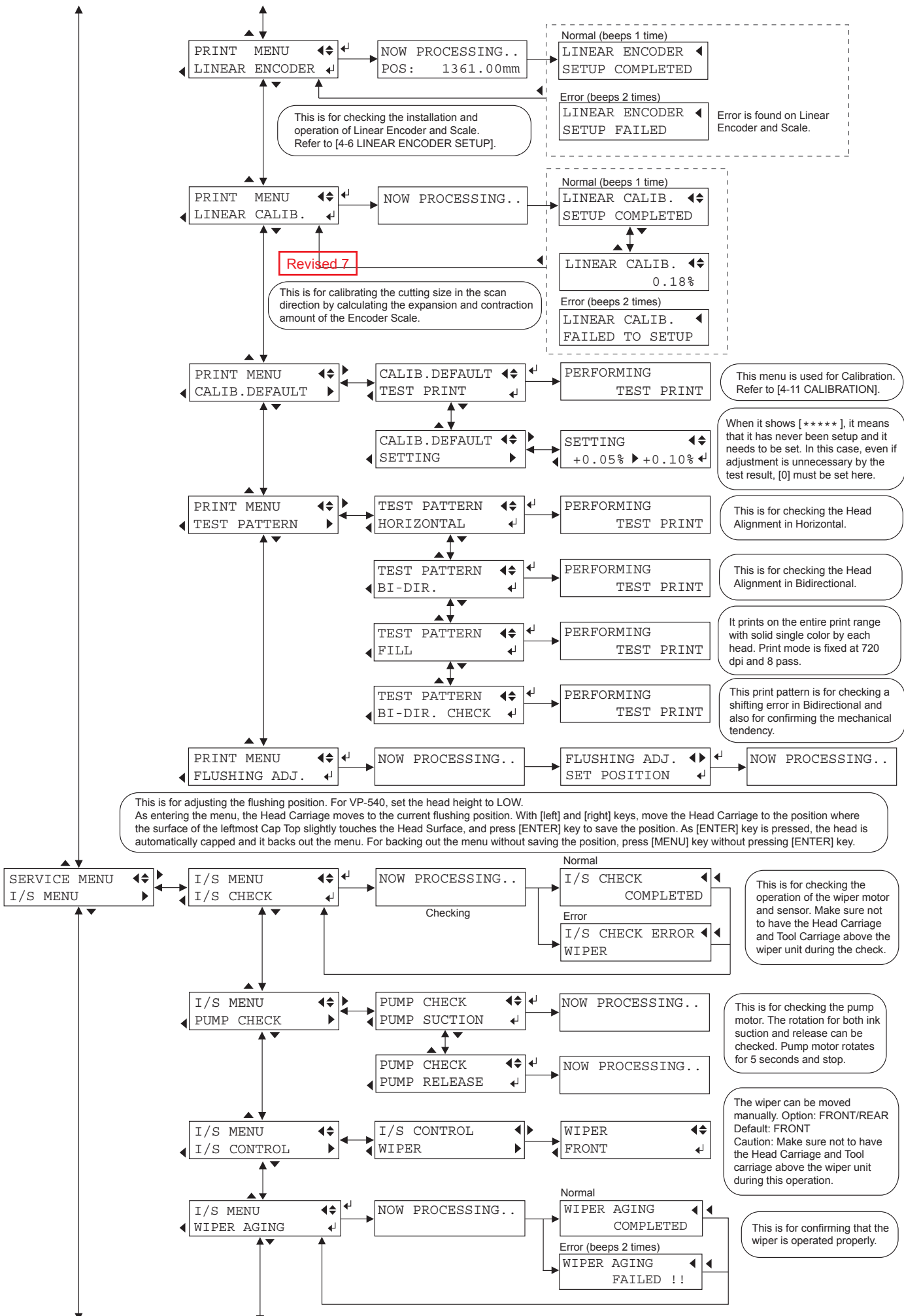

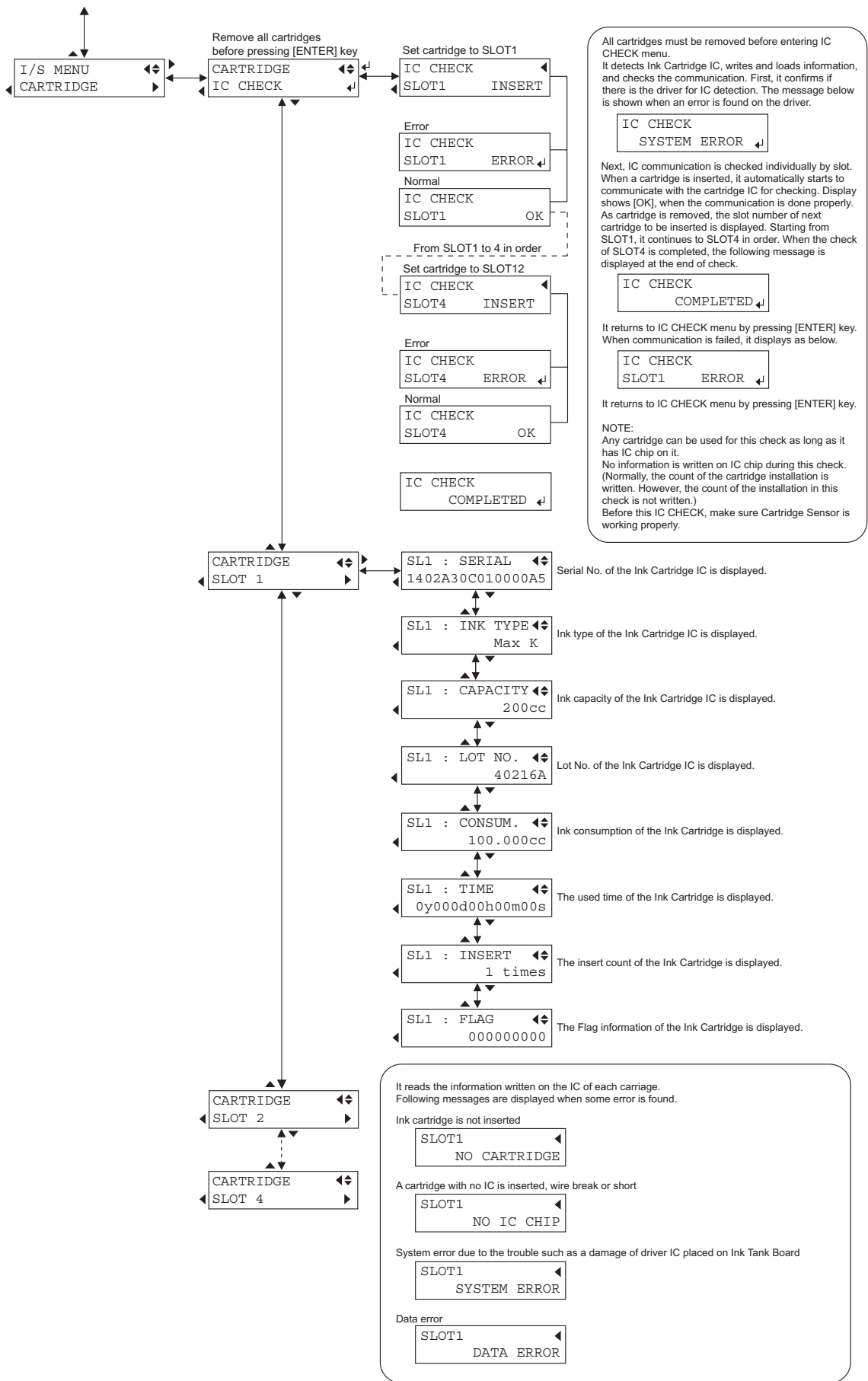

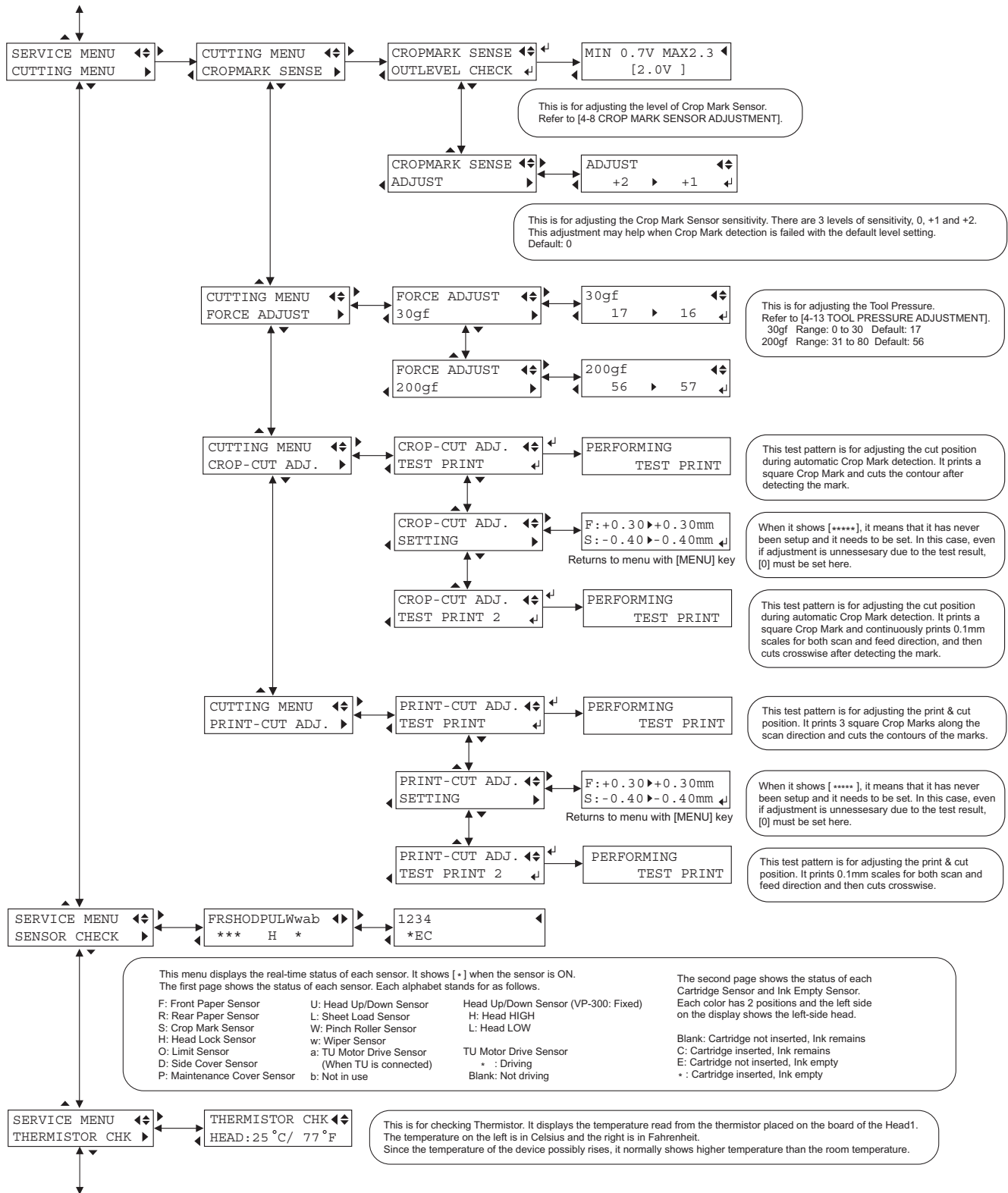

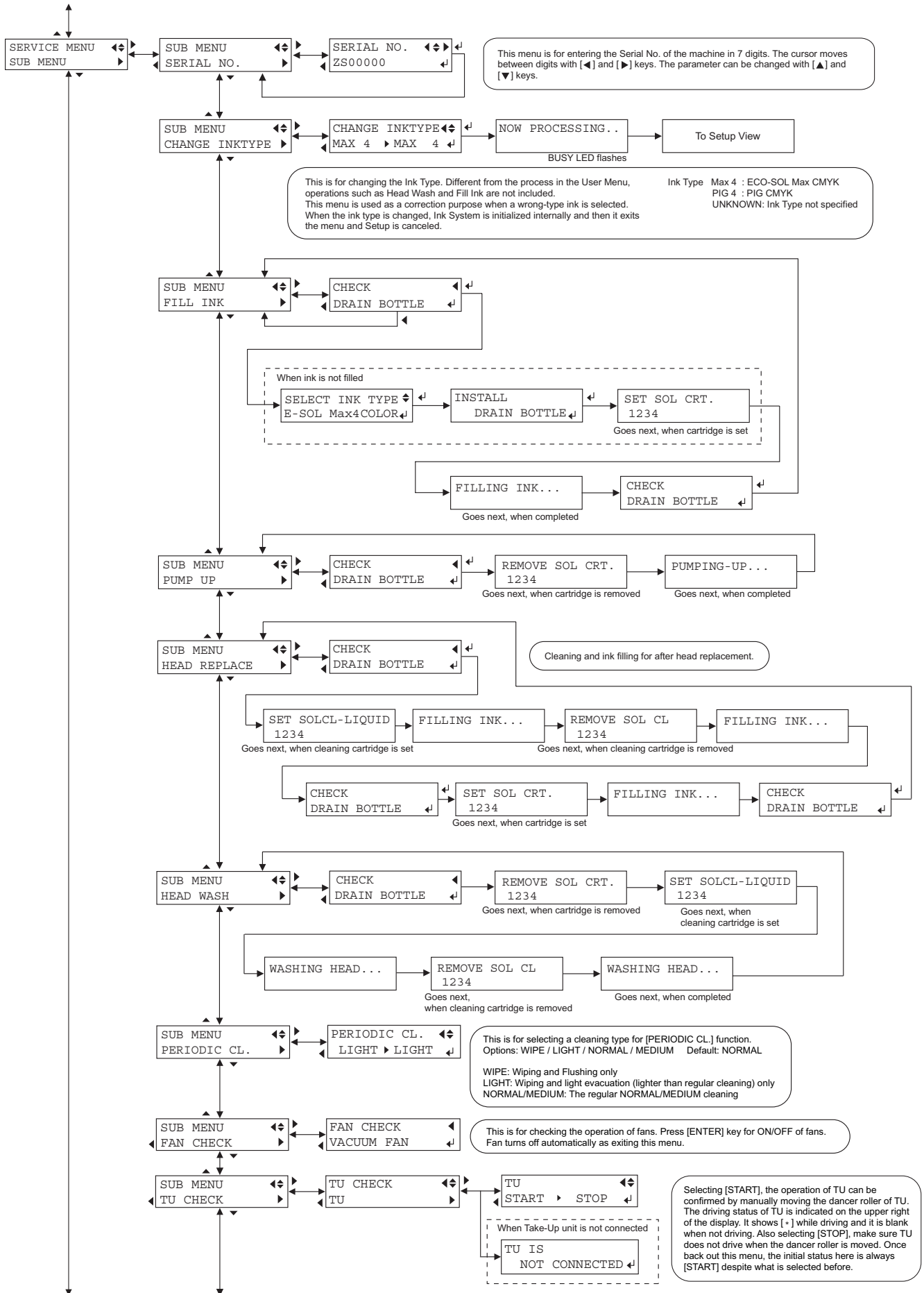

Revised 4

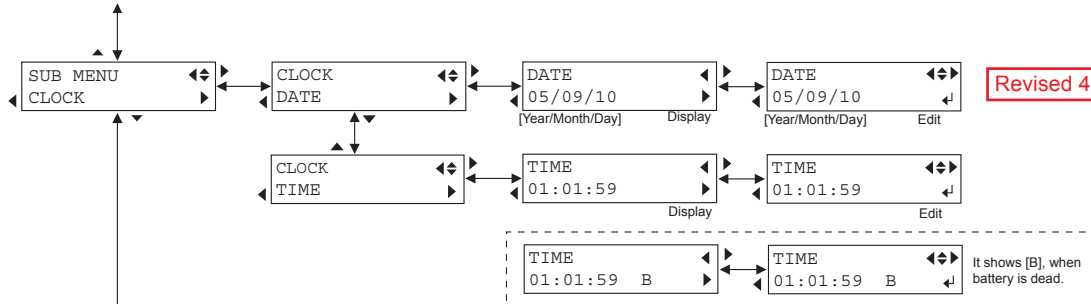

This is for displaying and editing the date and time. When it detects the battery exhaustion, [B] is indicated on the time display. In this case, battery needs to be replaced. However, [B] does not disappear automatically when the battery is replaced. [B] is deleted when the time is newly set up with [ENTER] key on the time edit menu.
 When the real time clock is not active due to battery exhaustion, the maintenance operation may be performed improperly. For instance, it performs cleaning every time the main power is turned on. The time set here is used for the timings of maintenance operations and for the time record of Event Log function. It must be aware that it affects the maintenance operations when the setting is changed here.
 When this setting is changed, it is recorded on the Event Log. The time before change is used for the log time, and the new time is recorded as a referential information.

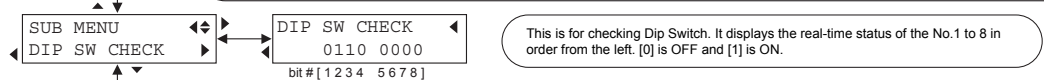

This is for checking Dip Switch. It displays the real-time status of the No.1 to 8 in order from the left. [0] is OFF and [1] is ON.

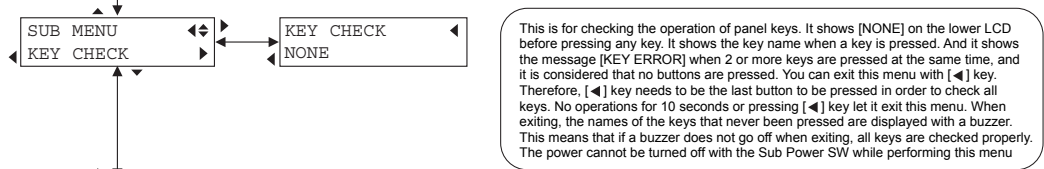

This is for checking the operation of panel keys. It shows [NONE] on the lower LCD before pressing any key. It shows the key name when a key is pressed. And it shows the message [KEY ERROR] when 2 or more keys are pressed at the same time, and it is considered that no buttons are pressed. You can exit this menu with [←] key. Therefore, [←] key needs to be the last button to be pressed in order to check all keys. No operations for 10 seconds or pressing [←] key let it exit this menu. When exiting, the names of the keys that never been pressed are displayed with a buzzer. This means that if a buzzer does not go off when exiting, all keys are checked properly. The power cannot be turned off with the Sub Power SW while performing this menu

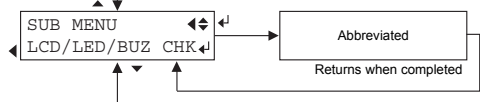

This is for checking LCD, LED and buzzer. When this menu is selected, it sequentially performs the functions of LCD, LED and buzzer. The functions are as follows. ON/OFF of LCD contrast, LCD back light, ON/OFF of buzzer, display and move of cursor on LCD, and display of all characters available on LCD. Confirm that all functions operate properly, visually and by the sound.

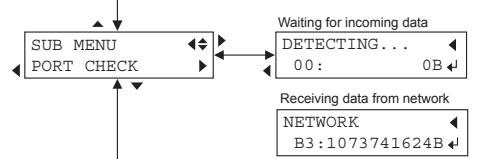

This is for checking the data input from network. The check sum and input data byte are shown on the lower LCD. On the left, it displays the check sum in hexadecimal of 2 digits. On the right, it displays the input data byte in decimal of max. 10 digits. They are cleared when [ENTER] key is pressed. The input data byte overflows at 4GB(4294967296B) and is reset to 0.

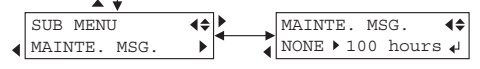

This is for setting the timing to show the message for maintenance. It displays the message suggesting to perform maintenance when the total print time reaches the specified hours. Range: NONE, 10 to 999 hours (in 10 hour unit) Default: NONE

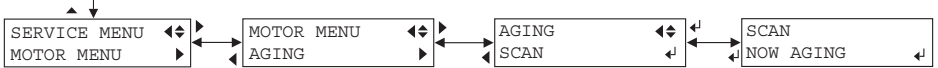

SCAN : Aging for Scan Motor.
 The Head Carriage runs max. printing width in Scan direction.
 FEED : Aging for Feed Motor.
 Grit Roller runs 100mm back and forth.
 BOTH : The Head Carriage runs max. printing width in Scan direction, and at the same time, Grit Roller runs 100mm back and forth.
 CUTTING : The Tool Carriage runs max. printing width in Scan direction, and at the same time, Grit Roller runs the half of max. printing width back and forth.

To stop Aging, press [ENTER] key. The Head Carriage automatically returns to the capping position, and it returns to the former menu after the Head is capped.
 Make sure not to perform Aging for excessive time when the head has ink, in order to prevent the head from being damaged by dried ink. When Aging is performed with ink filled, it runs while performing the Flushing operation. No Flushing when ink is not filled.

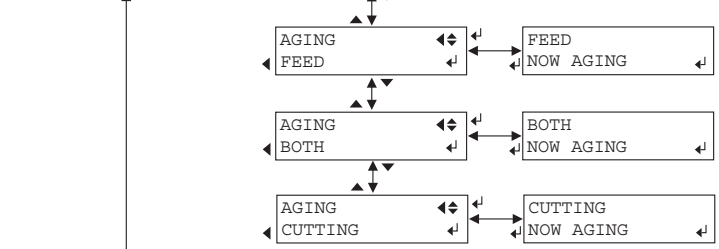

Servo Motor : LOCKED
 SERVO LOCK F: * 0 0
 Servo Motor : FREE
 SERVO LOCK F: 0 0

This is for checking whether Servo Motor can be locked properly. While in this menu, Servo Motor is free. When the Carriages are moved by hands, the displayed values change as long as the feed-back is proper. Servo Motor can be locked by pressing [ENTER] key. When it is locked while the motor is in pause, the power is controlled normally. As for [F(Feed direction)], the value displayed on the left changes by Grid Encoder, and the right changes by Motor Encoder.

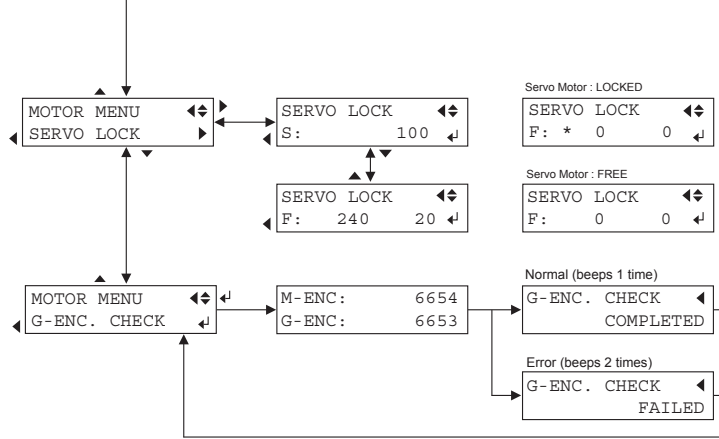

Normal (beeps 1 time)
 G-ENC. CHECK COMPLETED
 Error (beeps 2 times)
 G-ENC. CHECK FAILED

This is for checking whether the Grit Encoder functions normally. Be careful with the Feed Motor which drives as executing this menu. The motor drives about 4 times and it displays the coordinates of the stop position of Motor Encoder and Grit Encoder at each time. The result is judged by the last Encoder coordinates.

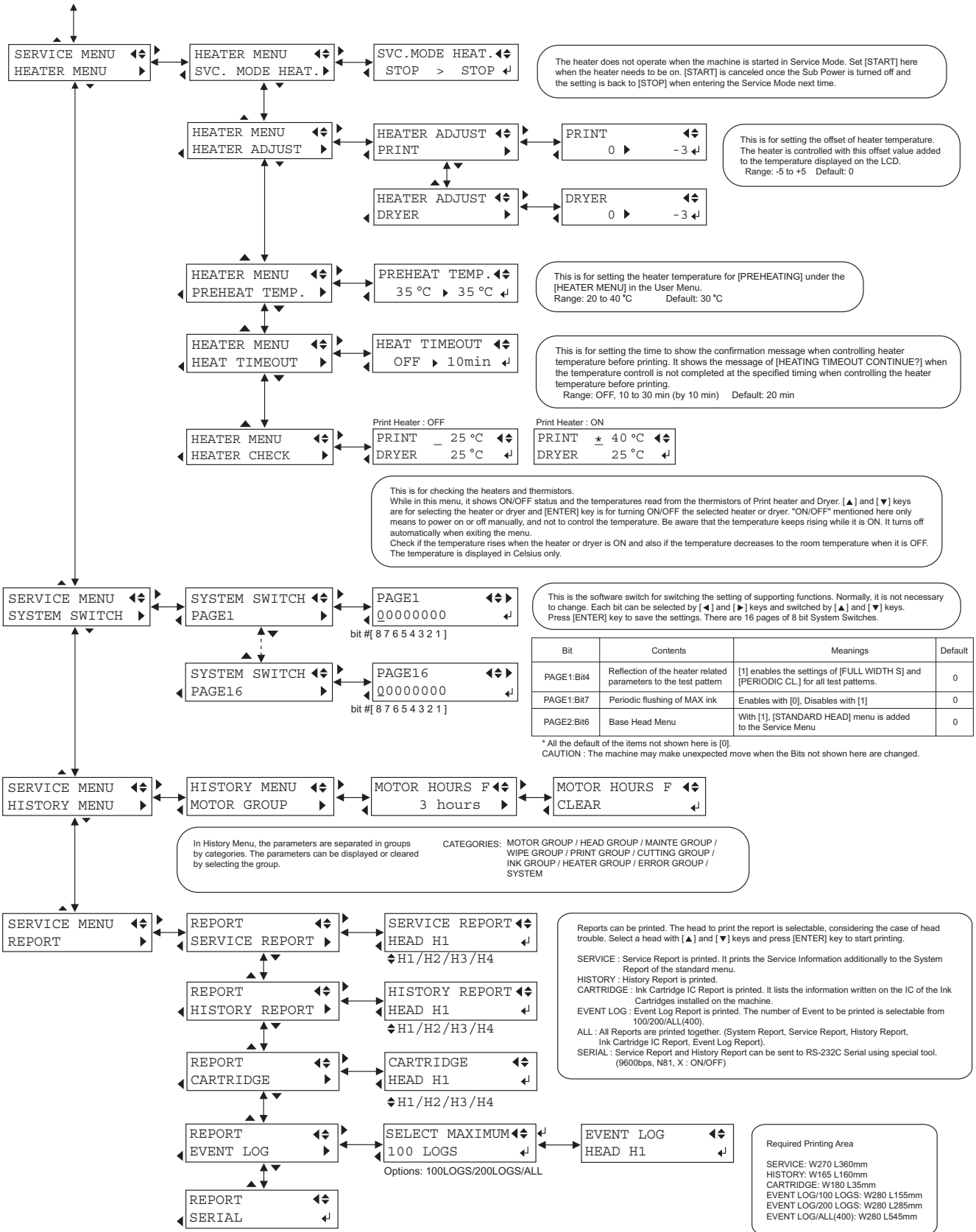

HISTORY MENU

MOTOR GROUP

Item	Contents	Unit	Reference
MOTOR FEED	Total time that the Feed Motor has been rotated.	hour	
MOTOR SCAN	Total time that the Scan Motor has been rotated.	hour	Life: 1500 hours
PUMP TIMES	Total time that the Pump Motor has been rotated.	times	Life: 200,000 times
CLEAR ALL	Clear all the value in the Motor Group.		

HEAD GROUP

Item	Contents	Unit	Reference
SHOT COUNT 1	Number of shots fired from the nozzle(H1 left)	Shots/1000	Life: 6 billion Shots/nozzle
SHOT COUNT 2	Number of shots fired from the nozzle(H1 right)	Shots/1001	Life: 6 billion Shots/nozzle
SHOT COUNT 3	Number of shots fired from the nozzle(H2 left)	Shots/1002	Life: 6 billion Shots/nozzle
SHOT COUNT 4	Number of shots fired from the nozzle(H2 right)	Shots/1003	Life: 6 billion Shots/nozzle
SHOT COUNT 5	Number of shots fired from the nozzle(H3 left)	Shots/1004	Life: 6 billion Shots/nozzle
SHOT COUNT 6	Number of shots fired from the nozzle(H3 right)	Shots/1005	Life: 6 billion Shots/nozzle
SHOT COUNT 7	Number of shots fired from the nozzle(H4 left)	Shots/1006	Life: 6 billion Shots/nozzle
SHOT COUNT 8	Number of shots fired from the nozzle(H4 right)	Shots/1007	Life: 6 billion Shots/nozzle
WIPE H1	Number of times the Wiping has been performed.(H1)	times	
WIPE H2	Number of times the Wiping has been performed.(H2)	times	
WIPE H3	Number of times the Wiping has been performed.(H3)	times	
WIPE H4	Number of times the Wiping has been performed.(H4)	times	
RUB H1	Number of times the Rubbing has been performed.(H1)	times	
RUB H2	Number of times the Rubbing has been performed.(H2)	times	
RUB H3	Number of times the Rubbing has been performed.(H3)	times	
RUB H4	Number of times the Rubbing has been performed.(H4)	times	
NORMAL CL. H1	Number of times the Normal Cleaning has been performed.(H1)	times	
NORMAL CL. H2	Number of times the Normal Cleaning has been performed.(H2)	times	
NORMAL CL. H3	Number of times the Normal Cleaning has been performed.(H3)	times	
NORMAL CL. H4	Number of times the Normal Cleaning has been performed.(H4)	times	
MEDIUM CL. H1	Number of times the Medium Cleaning has been performed.(H1)	times	
MEDIUM CL. H2	Number of times the Medium Cleaning has been performed.(H2)	times	
MEDIUM CL. H3	Number of times the Medium Cleaning has been performed.(H3)	times	
MEDIUM CL. H4	Number of times the Medium Cleaning has been performed.(H4)	times	
POWERFUL CL.H1	Number of times the Powerful Cleaning has been performed.(H1)	times	
POWERFUL CL.H2	Number of times the Powerful Cleaning has been performed.(H2)	times	
POWERFUL CL.H3	Number of times the Powerful Cleaning has been performed.(H3)	times	
POWERFUL CL.H4	Number of times the Powerful Cleaning has been performed.(H4)	times	
AUTO CL.H1	Number of times the Automatic Cleaning has been performed.(H1)	times	
AUTO CL.H2	Number of times the Automatic Cleaning has been performed.(H2)	times	
AUTO CL.H3	Number of times the Automatic Cleaning has been performed.(H3)	times	
AUTO CL.H4	Number of times the Automatic Cleaning has been performed.(H4)	times	
CLEAR H4	Clear all the value of the H4.		
CLEAR H3	Clear all the value of the H3.		
CLEAR H2	Clear all the value of the H2.		
CLEAR H1	Clear all the value of the H1.		
CLEAR ALL	Clear all the value of all the Head.		

MAINTENANCE GROUP

Item	Contents	Unit	Reference
MAINTEN. COUNT	Number of times the Head Maintenance([SUB MENU]>[MAINTENANCE]>[CLEANING]) has been performed.	times	
TOTAL TIME	Lapsed time from the last Head Maintenance	hour	This value is cleared automatically after carrying out the Head Maintenance.
PRINTING TIME	Printing time from the last Head Maintenance	hour	This value is cleared automatically after carrying out the Head Maintenance.
CLEAR ALL	Clear all the value in the MAINTENANCE GROUP.		

WIPE GROUP

Item	Contents	Unit	Reference
WIPING COUNT	Number of times the Wiping has been performed.	times	This value is cleared automatically after replacing it.
RUBBING COUNT	Number of times the Rubbing has been performed.	times	This value is cleared automatically after replacing it.
WIPE REPLACE	Number of times the Wipe has been replaced.	times	
CLEAR ALL	Clear all the value in the WIPE GROUP.		

PRINT GROUP

Item	Contents	Unit	Reference
PRINTING TIME	Total time of printing performed.	hour	test print time is excluded.
PRINT PAGES	Number of pages printed	pages	
CLEAR ALL	Clear all the value in the PRINT GROUP.		

CUTTING GROUP

Item	Contents	Unit	Reference
CUTTING TIME	Total time of cutting performed.	hour	Test print time is excluded.
DISCONNECT	Number of times the carriage has been disconnected.	times	Disconnection of Tool Carriage and Head Carriage.
CLEAR ALL	Clear all the value in the CUTTING GROUP.		

INK GROUP

Item	Contents	Unit	Reference
CARTRIDGE 1	Number of times the Ink Cartridge 1 has been changed.	times	
CARTRIDGE 2	Number of times the Ink Cartridge 2 has been changed.	times	
CARTRIDGE 3	Number of times the Ink Cartridge 3 has been changed.	times	
CARTRIDGE 4	Number of times the Ink Cartridge 4 has been changed.	times	
CHANGE INK	Number of times the Ink type has been changed.	times	
CLEAR ALL	Clear all the value in the INK GROUP.		

ERROR GROUP

Item	Contents	Unit	Reference
SERVICE CALL	Number of times the Service Call has occurred.	times	
S-CALL HISTORY	Service Call Number of the last 5 Calls.	No.	
MOTOR ERROR F	Number of times the Feed Motor Error has occurred.	times	
MOTOR ERROR S	Number of times the Scan Motor Error has occurred.	times	
LOW TEMP.ERR.	Number of times the Low Temperature Error has occurred.	times	
HIGH TEMP.ERR.	Number of times the High Temperature Error has occurred.	times	
EMERG. CAPPING	Number of times the Emergency Capping Error has occurred.	times	Number of times of forced capping for Head dry prevention that works when cap is left open for 3 minutes or more due to cover open or other reasons.
START UNCAPPED	Number of times the machine has started uncapped.	times	When cap is left open, it is detected when machine is started.
CLEAR ALL	Clear all the value in the ERROR GROUP.		

HEATER GROUP

Item	Contents	Unit	Reference
PRINT USE TIME	Total time of Print Heater used.	hour	
DRY USE TIME	Total time of Dryer used.	hour	
CLEAR ALL	Clear all the value in the HEATER GROUP.		

SYSTEM GROUP

Item	Contents	Unit	Reference
POWER ON COUNT	Number of times Sub Power has been turned on.	times	
POWER ON TIME	Total time of Sub Power ON.	hour	Sleep time is excluded.
SLEEP TIME	Total time of the machine in Sleep Mode.	hour	
SHEETCUT COUNT	Number of times the Sheet Cut has been performed.	times	It counts Auto Sheet Cut performed by both printer and RIP.
CLEAR ALL	Clear all the value in the SYSTEM GROUP.		

SERVICE REPORT

Service Report

```

Head rank H1      : 75Y383DSXTZWWST ..... 006..D
           H2      : 6A03737VVVYVVRT ..... 002..D
           H3      : 7AV4040TURXYXRS ..... 00L..D
           H4      : 76V3937STSWXXSU ..... 00W..D
  
```

	H1	H2	H3	H4
Head hori.(DT1. Low)	: +1	0	0	
(DT3. Low)	: +1	0	+0.5	
(DT1. High)	: +1	0	+1	
(DT3. High)	: +1.5	0	0	
Head bi (DT1. Low)	: +10	+9.5	+10	+9
(DT3. Low)	: +8	+7	+8	+7
(DT1. High)	: +20	+18.5	+21	+19
(DT3. High)	: +16	+15.5	+17	+16

```

Dip SW : 00000000
System SW page ( 1- 4) : 00000000 00000000 00000000 00000000
System SW page ( 5- 8) : 00000000 00000000 00000000 00000000
System SW page ( 9-12) : 00000000 00000000 00000000 00000000
System SW page (13-16) : 00000000 00000000 00000000 00000000
Network I/F version : Print Server 1.1 (Tue May 30 14:46:26 JST 2006)
Maintenance request : NONE
Booter version : 1.00
Battery : Charged
Periodic CL. degree : NORMAL
Limit position : 25.6 mm
Cutter down position : 1725.8 mm
Calibration default : -0.26 %
Encoder position(L) : 1516.6 mm
Encoder position(R) : 145.0 mm

Heater adjust (PRINT) : 0 C
Heater adjust (DRYER) : 0 C
Preheat temperature : 30 C
Heating timeout : 20 min
Drain liquid volume : 192.0 cc
Standard head : 1
Flushing pos adjust : 0.00 mm

Environment match : +0.028 %
Encorder calibration : +0.028 %
Crop-tool adjust (F/S) : -0.40/ 0.00 mm
Print-cut adjust (F/S) : -0.20/ +0.60 mm
Force adjust 30gf : 14
Force adjust 200gf : 53
  
```

Roland Versa CAMM series

Model	: VP-540	IP Address	: 192.168.000.100	Ink type	: E-SOL Max 4Color
Version	: 1.00	Subnet Mask	: 255.255.255.000	Ink remain (1-4)	: 76/ 62/ 59/ 73
Serial No.	: XXXXXXX	Gateway Address	: 000.000.000.000		
Date	: 2007/01/11 14:19	MAC Address	: 00:40:AB:00:0C:E1		
Head Temperature	: 27 °C / 82.4 °F	Heater temp. (PRINT)	: 28 °C / 82 °F		
		Heater temp. (DRYER)	: 26 °C / 78 °F		
Menu language	: Japanese	Calibration	: +1.00 %	Vacuum power	: Auto
Length unit	: mm	Full width scanning	: FULL	Set remain at loading	: Disable
Temperature unit	: C	Scan interval	: 0.0 sec	Heater setting (PRINT)	: 35 °C / 94 °F
Head height	: Low	Sleep	: Enable	Heater setting (DRYER)	: 40 °C / 104 °F
Edge detection	: Enable	Sleep interval	: 30 min	Feed for dry	: Disable
Empty mode	: Stop	Sheet remain	: 0.0m	Preheating	: PREHEAT
Bi-dir. simple	: 0	Periodic cleaning	: NONE	Media clamp	: SHORT
Bi-dir. adjust No.1	: -4.5 -4 -3.5 -3.5			No.3 : -5 -4 -4 -4.5	
No.2	: 0 0 0 0			No.4 : -2 -2 -2.5 -2	
Tool parameter					
Force	: 90 gf	Cutting calib. (F/S)	: 0.00/ 0.00 %	Cutting priority	: Command
Velocity	: 30 cm/s	Print-cut adjust (F/S)	: 0.00/ -0.05 mm	Prefeed	: Disable
Offset	: 0.250 mm	Crop-cut adjust (F/S)	: +0.10/ +0.05 mm	Auto Env Match	: Enable
Up velocity	: 30 cm/s				
Preset name	: PRESETTING1				
Calibration	: 0.00 %	Scan interval	: 0.0 sec	Force	: 50 gf
Heater setting (PRINT)	: 35 °C / 94 °F	Edge detection	: Enable	Velocity	: 30 cm/s
Heater setting (DRYER)	: 40 °C / 104 °F	Full width S	: FULL	Offset	: 0.250 mm
Feed for dry	: Disable	Preheating	: Preheat	Up velocity	: 30 cm/s
Bi-dir. simple	: 0	Vacuum power	: AUTO		
Bi-dir. Adjust No.1	: 0 / 0 / 0 / 0			No.3 : 0 / 0 / 0 / 0	
No.2	: 0 / 0 / 0 / 0			No.4 : 0 / 0 / 0 / 0	
Preset name	: PRESETTING2				
Calibration	: 0.00 %	Scan interval	: 0.0 sec	Force	: 50 gf
Heater setting (PRINT)	: 35 °C / 94 °F	Edge detection	: Enable	Velocity	: 30 cm/s
Heater setting (DRYER)	: 40 °C / 104 °F	Full width S	: FULL	Offset	: 0.250 mm
Feed for dry	: Disable	Preheating	: Preheat	Up velocity	: 30 cm/s
Bi-dir. simple	: 0	Vacuum power	: AUTO		
Bi-dir. Adjust No.1	: 0 / 0 / 0 / 0			No.3 : 0 / 0 / 0 / 0	
No.2	: 0 / 0 / 0 / 0			No.4 : 0 / 0 / 0 / 0	

Preset name	: PRESETTING8				
Calibration	: 0.00 %	Scan interval	: 0.0 sec	Force	: 50 gf
Heater setting (PRINT)	: 35 °C / 94 °F	Edge detection	: Enable	Velocity	: 30 cm/s
Heater setting (DRYER)	: 40 °C / 104 °F	Full width S	: FULL	Offset	: 0.250 mm
Feed for dry	: Disable	Preheating	: Preheat	Up velocity	: 30 cm/s
Bi-dir. simple	: 0	Vacuum power	: AUTO		
Bi-dir. Adjust No.1	: 0 / 0 / 0 / 0			No.3 : 0 / 0 / 0 / 0	
No.2	: 0 / 0 / 0 / 0			No.4 : 0 / 0 / 0 / 0	

HISTORY REPORT

History Report

Model : VP-540 Serial No. : XXXXXXXX
Version : 1.00 Date : 2007/01/11 14:24

==== Motor group ====

Motor feed (trip / total [clear]):	0/	0	hours	[0]
Motor scan (trip / total [clear]):	9/	9	hours	[0]
Pump Times (trip / total [clear]):	1,703/	1,703	times	[0]

==== Maintenance group ====

Mainte. count	:	0	times
Total time	:	483	hours
Printing time	:	8	hours

==== Wiper group ====

Wiping count	:	86	times
Rubbing count	:	6	times
Wiper replace count	:	0	times

==== Head group ====

Shot Cnt. 1 (trip/total [clear]):	2,697/	2,697
Shot Cnt. 2 (trip/total [clear]):	2,701/	2,701
Shot Cnt. 3 (trip/total [clear]):	10,361/	10,361
Shot Cnt. 4 (trip/total [clear]):	10,357/	10,357
Shot Cnt. 5 (trip/total [clear]):	12,166/	12,166
Shot Cnt. 6 (trip/total [clear]):	12,137/	12,137
Shot Cnt. 7 (trip/total [clear]):	4,786/	4,786
Shot Cnt. 8 (trip/total [clear]):	4,767/	4,767

	:	H1	H2	H3	H4	
Wiping count for head	:	43	43	43	43	times
Rubbing count for head	:	3	3	3	3	times
Headrank set count	:	0	0	0	0	times
Auto cleaning count	:	17	17	17	17	times
Normal cleaning count	:	4	4	4	4	times
Medium cleaning count	:	0	0	0	0	times
Powerful cleaning count	:	1	1	1	1	times

==== Print group ====

Printing time	:	6	hours
Print pages	:	34	pages

==== Ink group ====

Cartridge change(1-4)	:	0	1	2	0	times
Change ink type	:	0	times			

==== Error group ====

Service call count	:	0	times			
Service call history	:	****	****	****	****	****
Motor error (feed)	:	0	times			
Motor error (scan)	:	2	times			
Low temperature error	:	0	times			
High temperature error	:	0	times			
Emergency capping	:	0	times			
Start uncapped	:	2	times			

==== Heater group ====

	:	PRINT	DRYER	
Heater used time	:	6	6	hours

==== System group ====

Power on count	:	97	times
Power on time	:	37	hours
Sleep time	:	2	hours
Sheet cut count	:	33	times
Peck used count	:	0	times

==== Cutting group ====

Cutting time	:	0	hours
Disconnect carr. count	:	67	times

INK CARTRIDGE REPORT

Ink Cartridge Report

Model : VP-540 Serial No. : XXXXXXXX
 Version : 0.50

No:	SERIAL/	INK TYPE/	CAP./LOT No/	CONSUM./	TIME/ INS./	FLAG
1:	14d178b002000071/	eSOL K/	200cc/60907A/	47.879cc/0y015d04h14m08s/	1/00000000	
2:	000000018ebb7700/	eSOL C/	200cc/61004A/	75.914cc/0y015d04h14m03s/	1/00000000	
3:	000000018ef67200/	eSOL M/	200cc/61021A/	81.901cc/0y015d04h13m58s/	1/00000000	
4:	000000018f613b00/	eSOL Y/	200cc/61026A/	53.789cc/0y015d04h13m52s/	1/00000000	

EVENT LOG REPORT

Event log Report

Model :VP-540				Serial No. : XXXXXXXX			
Version :0.50				Date : 2007/01/11 17:20			
Date	Time	Temp.	Event	Date	Time	Temp.	Event
Information				Information			
07/01/11	17:20	27	Print start	07/01/10	12:57	26	Print start
06/01/11	17:19	27	Print done	07/01/10	12:56	26	Print done
06/01/11	17:18	27	Print start	06/01/10	12:55	26	Print start
06/01/11	17:17	27	Print done	06/01/10	12:55	26	Setup done
06/01/11	17:14	27	Print start	06/01/10	12:53	26	Cancel done
06/01/11	17:14	27	Print done	06/01/10	12:53	26	Cancel start
06/01/11	17:13	27	Print start	06/01/10	12:53	26	Setup done
06/01/11	17:11	27	Print done	06/01/10	12:52	26	Cancel done
06/01/11	17:09	28	Print start	06/01/10	12:52	26	Cancel start
06/01/11	17:09	28	Print done	06/01/10	12:50	26	Print done
06/01/11	17:06	28	Print start	06/01/10	12:49	26	Print start
06/01/11	17:06	28	Setup done	06/01/10	12:48	26	Setup done
06/01/11	17:05	28	Sub power on	06/01/10	12:46	26	Sub power on
06/01/11	15:59	27	Sub power off	06/01/10	12:46	26	Main power on
06/01/11	15:56	27	Print done	06/01/10	12:46	26	Sub power off
06/01/11	15:54	28	Print start	06/01/10	12:08	26	Setup done
06/01/11	15:53	27	Setup done	06/01/10	12:07	26	Cancel done
06/01/11	15:52	27	Sub power on	06/01/10	12:07	26	Cancel start
06/01/11	15:13	28	Sub power off	06/01/10	12:07	26	Setup done
06/01/11	15:00	28	Print done	06/01/10	12:05	26	Cancel done
06/01/11	14:59	28	Print start	06/01/10	12:05	26	Cancel start
06/01/11	14:57	28	Print done	06/01/10	12:03	27	Print done
06/01/11	14:55	28	Print start	06/01/10	12:03	27	Print start
06/01/11	14:55	28	Setup done	06/01/10	12:02	26	Print done
06/01/11	14:54	28	Sub power on	06/01/10	12:01	26	Print start
06/01/11	14:39	28	Sub power off	06/01/10	12:01	26	Print done
06/01/11	14:38	28	Print done	06/01/10	12:00	26	Print start
06/01/11	14:36	28	Print start	06/01/10	11:59	26	Print done
06/01/11	14:36	28	Print done	06/01/10	11:59	26	Print start
06/01/11	14:36	28	Print start	06/01/10	11:50	26	Setup done
06/01/11	14:35	28	Print done	06/01/10	11:49	26	Sub power on
06/01/11	14:33	28	Print start	06/01/10	11:48	26	Sub power off
06/01/11	14:32	28	Setup done	06/01/10	11:47	26	Print done
06/01/11	14:28	28	Sub power on	06/01/10	11:47	26	Print start
06/01/10	23:57	28	Sub power off	06/01/10	11:45	26	Print done
06/01/10	13:10	26	Print done	06/01/10	11:44	26	Print start
06/01/10	13:10	26	Print start	06/01/10	11:42	26	Print done
06/01/10	13:06	26	Print done	06/01/10	11:40	26	Print start
06/01/10	13:04	26	Print start	06/01/10	11:39	26	Print done
06/01/10	13:04	26	Print done	06/01/10	11:39	26	Print start
06/01/10	13:03	26	Print start	06/01/10	11:38	26	Print done
06/01/10	13:02	26	Print done	06/01/10	11:37	26	Print start
06/01/10	13:01	26	Print start	06/01/10	11:36	26	Setup done
06/01/10	13:01	26	Print done	06/01/10	11:33	26	Sub power on
06/01/10	13:00	26	Print start	06/01/10	11:29	25	Sub power off
06/01/10	12:59	26	Print done	06/01/10	11:28	26	Sub power on
06/01/10	12:59	26	Print start	06/01/10	11:27	25	Main power on
06/01/10	12:58	26	Print done	06/01/10	11:27	25	Sub power off
06/01/10	12:58	26	Print start	06/01/10	11:27	25	Error
06/01/10	12:57	26	Print done	06/01/10	11:36	25	Print start

Other Factory Mode

SYSTEM PARAMETER INITIALIZE

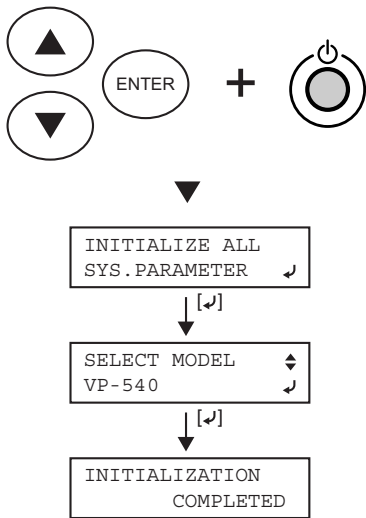

All parameters will be initialized. Turn on the Sub Power SW while pressing [▲], [▼] and [ENTER] keys to start the machine in system parameter initialize mode.

Select the model by pressing [▲] and [▼] keys.

Press [ENTER] key to initialize the system parameter or press the Sub Power SW more than 1 second to cancel it. The machine turns off automatically when the initialization is completed. All the parameters are reset to the default.

It is necessary to initialize the limit position after this initialization. [SERVICE CALL 0101] occurs without initializing the limit position.

LANGUAGE / UNIT SELECTION

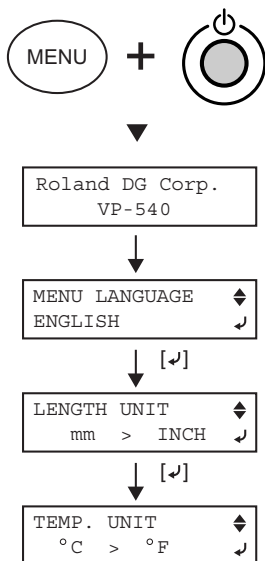

SERVICE REPORT PRINTING

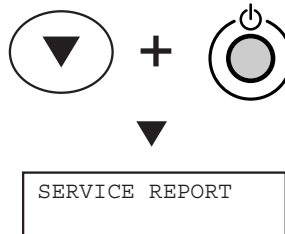





Turn on the Sub Power SW while pressing [▼] key to start the machine in the service report printing mode.

The service report will be printed automatically when the media is set up. It prints with Black ink.

(Printing Area : W270 L360mm)

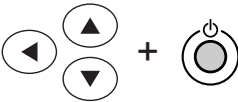
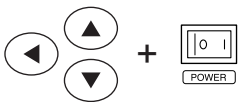
The machine turns to be the normal mode after printing.

Key Combinations

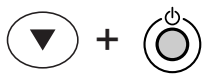
Function for Service	Combination Key Selection	Comments
Service Mode		Press [MENU] and [▶] to enter Service Menu.
F/W Upgrade Mode		[UPDATE FIRMWARE?] will be displayed. Press [ENTER] to upgrade F/W.
F/W Installation Mode for a brand-new Main Board		Use this when the Main Board is replaced.
		[SUM-ERROR] will be displayed. Press [ENTER] to upgrade F/W.
System Parameter Initialize		All parameters will be initialized. Press [ENTER] to start initialize.
Limit Position/Cut Down Position Initialize		Press [ENTER] to initialize Limit Position. Then set up Cut Down Position.
Service Report		Service Report will be printed. It is the same as the Service Report in the Service Menu.

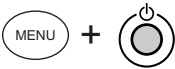
Function for Users	Combination Key Selection	Comments
Language/Unit Selection		Press [▲] and [▼] to select Language/Unit.

4-2 HOW TO UPGRADE/INSTALL FIRMWARE

It is necessary to prepare the followings to upgrade/install the firmware.

1. Firmware file
2. Windows PC (Network port is required.)
3. Peck4.exe
4. Network cable (A cross cable is required when you connect VP-540/300 to PC directly.)

HOW TO UPGRADE FIRMWARE (Referential Time : 5 min)

- 1** Check the IP address of VP-540/300.
Turn on the Main Power SW and Sub Power SW, then press [MENU] key.
Select [SYSTEM INFO.]> [NETWORK]> [IP ADDRESS].

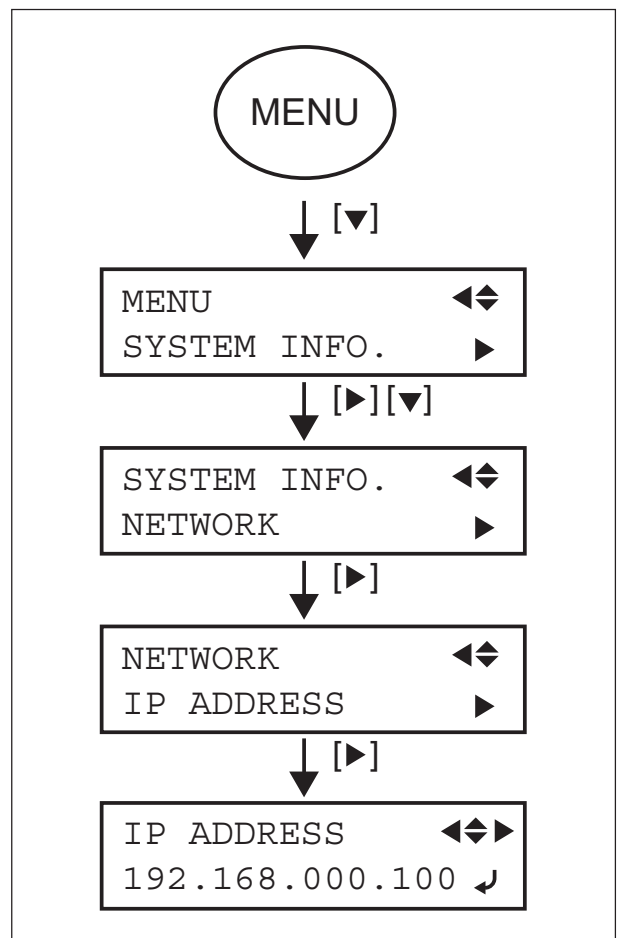

- 2** Turn off the Sub Power SW.

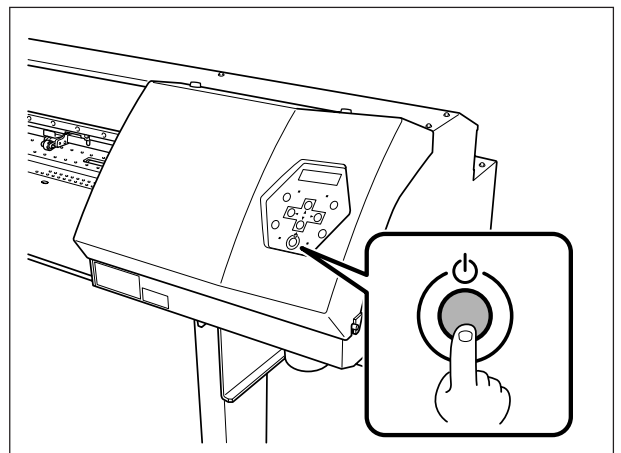

- 3** Start the Peck4.
[Peck4] screen is displayed, and click [Select Port] button.

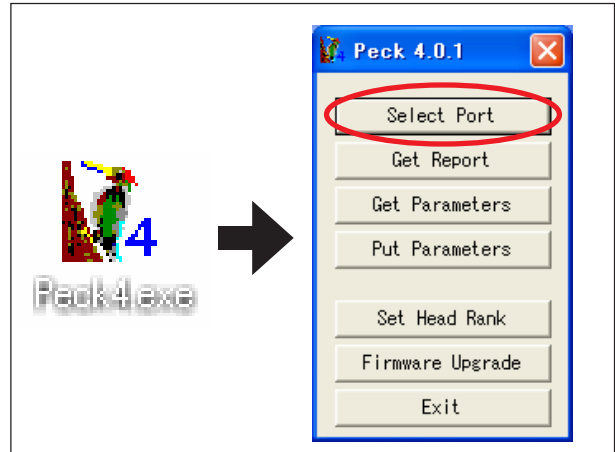

- 4** Select [Type3 ProIII etc.] from [Product].
Also, select [Via Network] and input IP address of VP-540/300.

Click [OK] button.

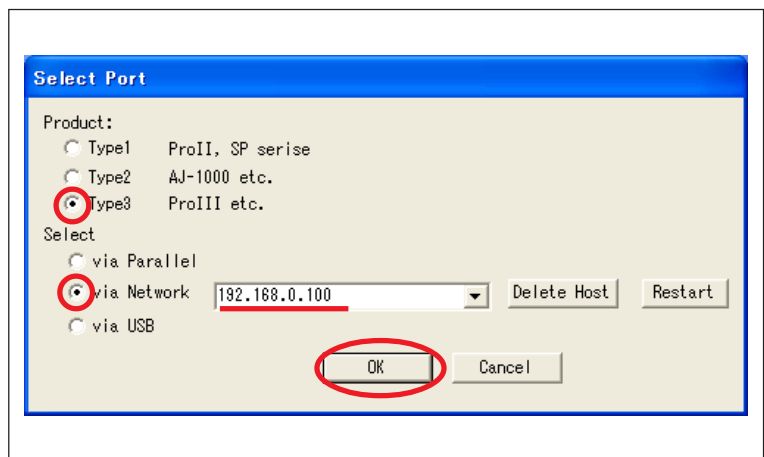

- 5** [Peck4] screen is displayed again.
Click [Firmware Upgrade] button.

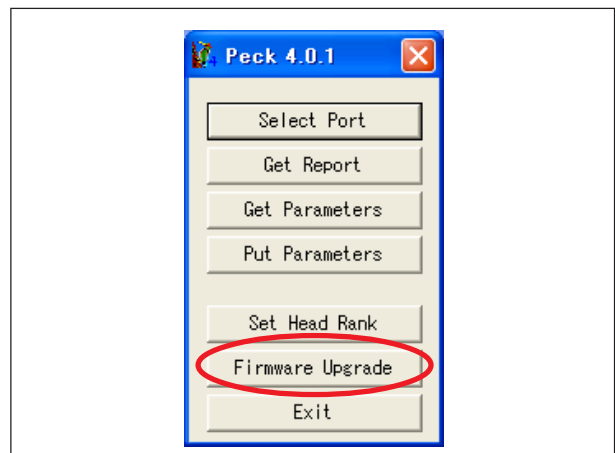

- 6** [OPEN] screen is displayed.
Select the firmware file and click [Open].
It starts to send the firmware to VP-540/300.

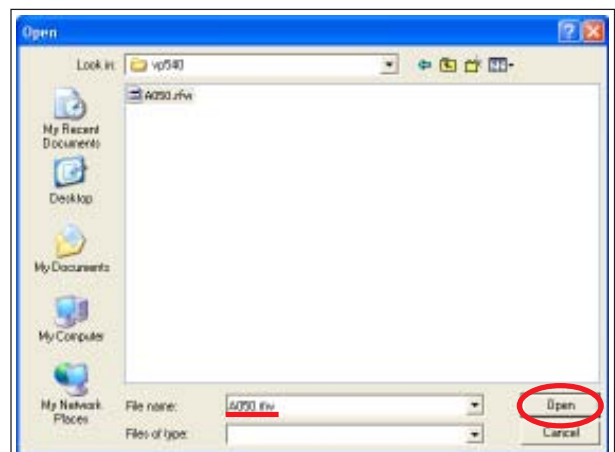

- 7** The machine goes into the Firmware Upgrade mode automatically.
When upgrade is completed, the Sub Power turns off automatically.

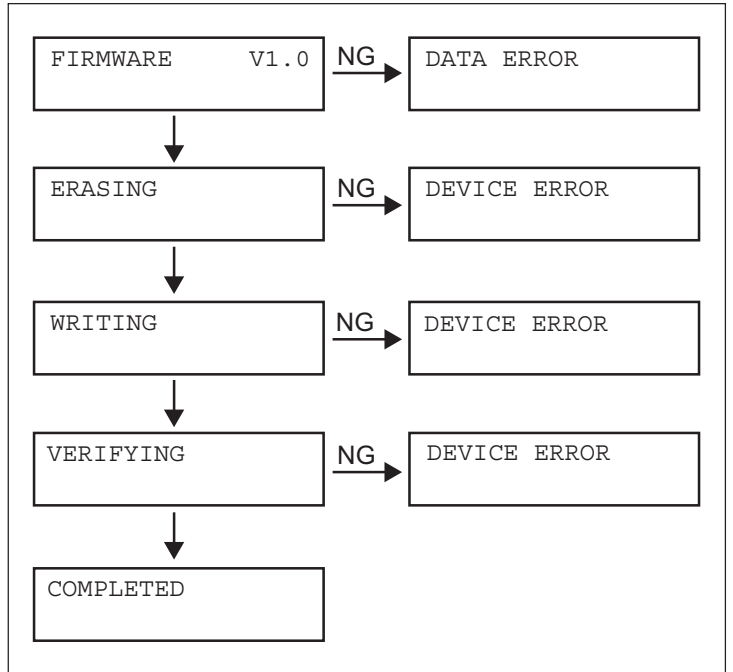

HOW TO INSTALL FIRMWARE (Referential Time : 10 min)

This is required when a new Main Board without the firmware is installed.

- 1** Turn on the Main Power SW while pressing [◀], [▲], and [▼] keys.

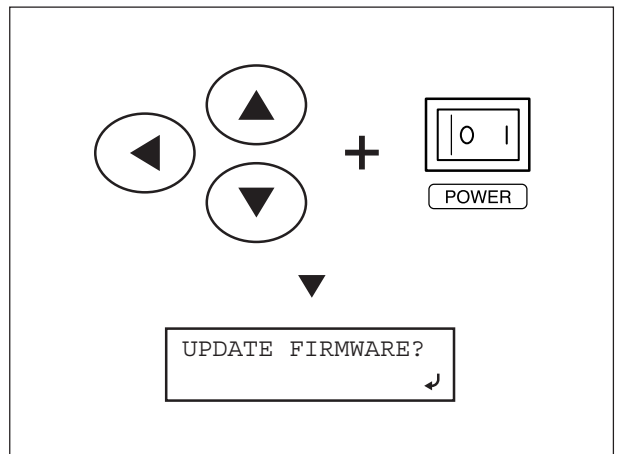

- 2** Press [ENTER] key to set the machine ready to receive the firmware.

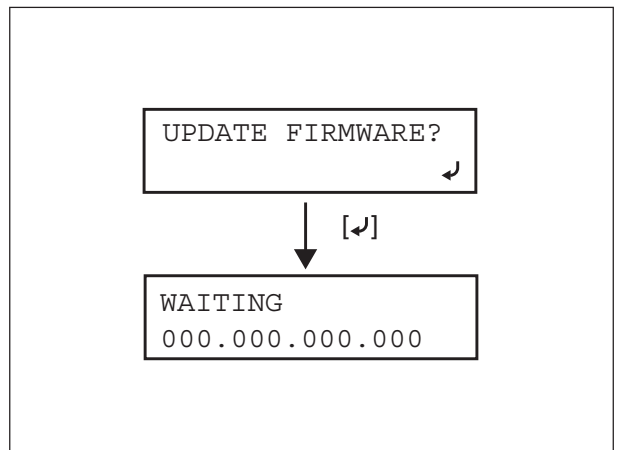

- 3** Press [MENU] key, and set [IP ADDRESS], [SUBNET MASK] and [GATEWAY ADDR.].

Press [◀] and [▶] keys for moving between digits, and [▲] and [▼] keys for selecting value. After setting an address, press [ENTER] key to go next address setting. When [GATEWAY ADDR.] is set, it returns to the waiting mode for receiving the firmware by pressing [ENTER] key.



The setting made here is only temporary for the firmware installation and it is not saved.

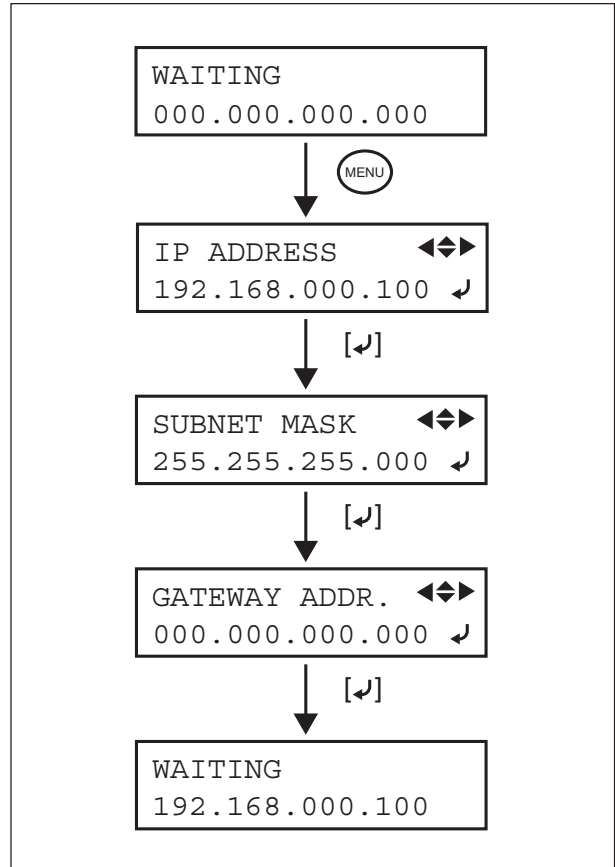

- 4** Start the Peck4 on PC.
[Peck4] screen is displayed, and click [Select Port] button.

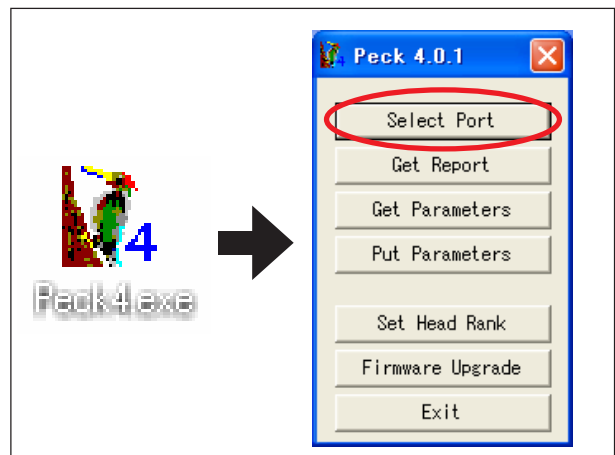

- 5** Select [Type3 ProIII etc.] from [Product].
Also, select [Via Network] and input IP address of VP-540/300.

Click [OK] button.

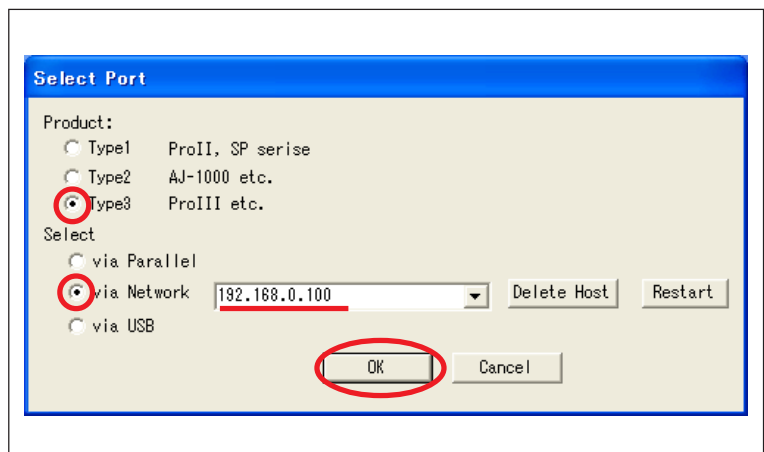

- 6 [Peck4] screen is displayed again.
Click [Firmware Upgrade] button.



- 7 [OPEN] screen is displayed.
Select the firmware file and click [Open].
It starts to send the firmware to VP-540/300.

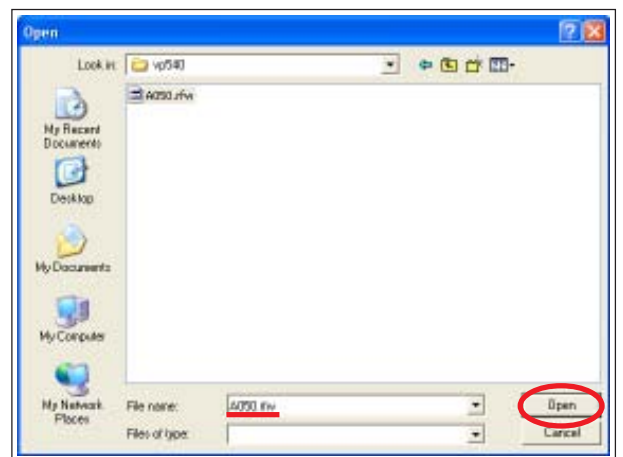

- 8 It starts loading the firmware.
The firmware installation is completed when [COMPLETED] message is displayed.
Turn off the Sub Power.

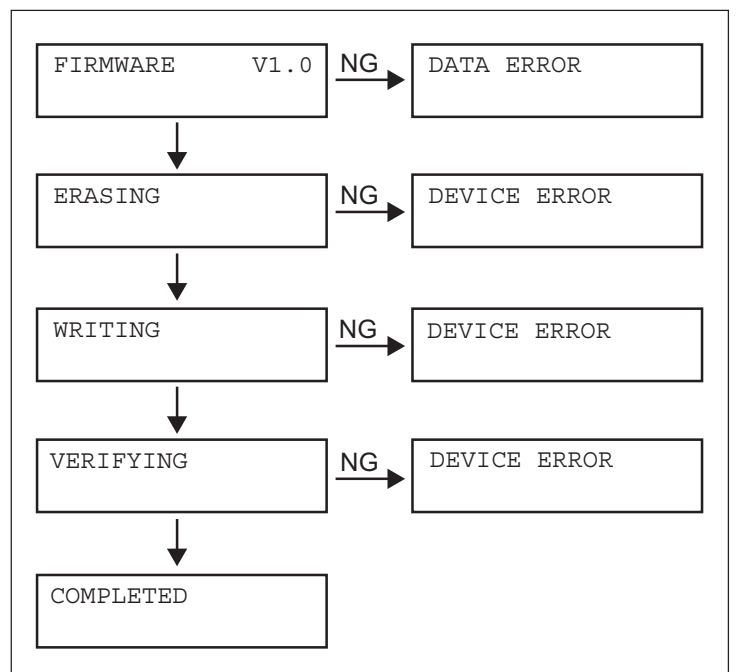

9 Turn on the Sub Power SW while pressing [▲], [▼], and [ENTER] keys to enter [INITIALIZE ALL SYS. PARAMETER] menu.

Select the model by pressing [▲] and [▼] keys, and press [ENTER] key to start initialization. The Sub Power turns off automatically when it is completed.

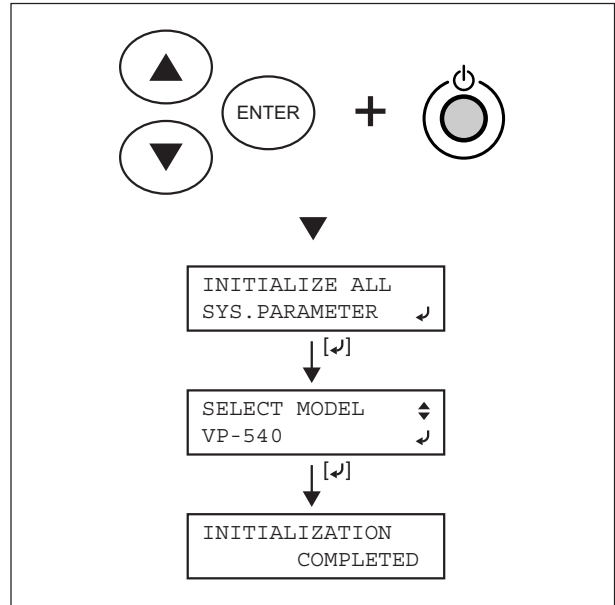

10 Turn on the Sub Power SW while pressing [◀], [▼] and [▶] keys to enter the Service Mode.

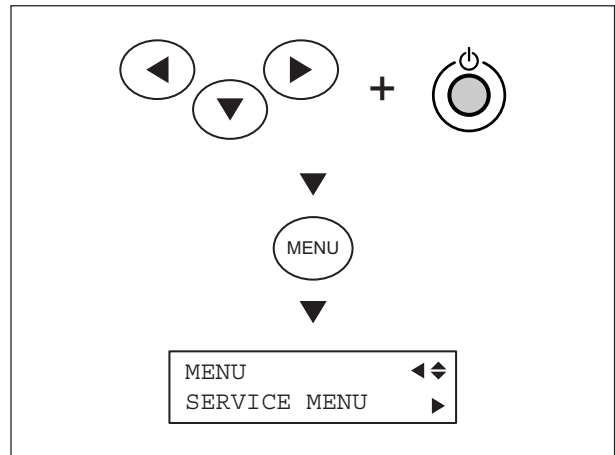

11 Enter the [NETWORK] menu and input [IP ADDRESS], [SUBNET MASK] and [GATEWAY ADDR.].

Turn off the Sub Power when the network setting is completed.

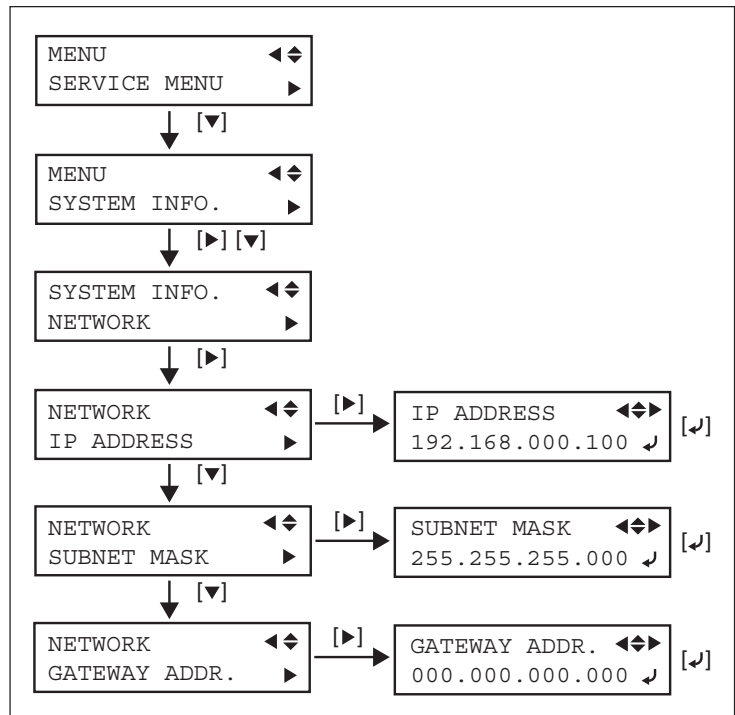

- 12 Start the Peck4 on PC.
[Peck4] screen is displayed, and click [Put Parameters] button.

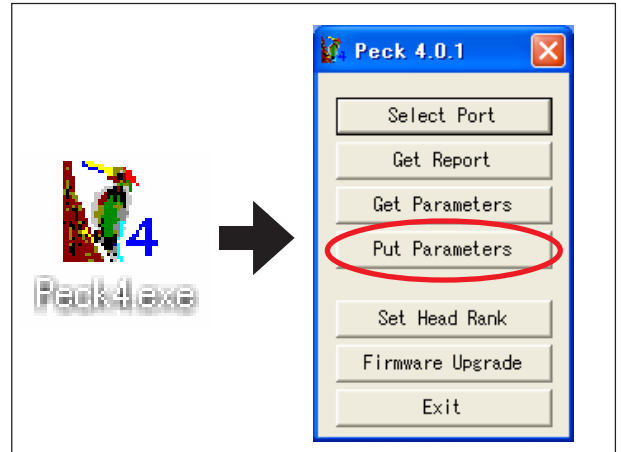

- 13 [OPEN] screen is displayed.
Select the System Parameter file that is saved before the Main Board replacement.
Click [Open]. Peck4 starts to send the System Parameter to VP-540/300.

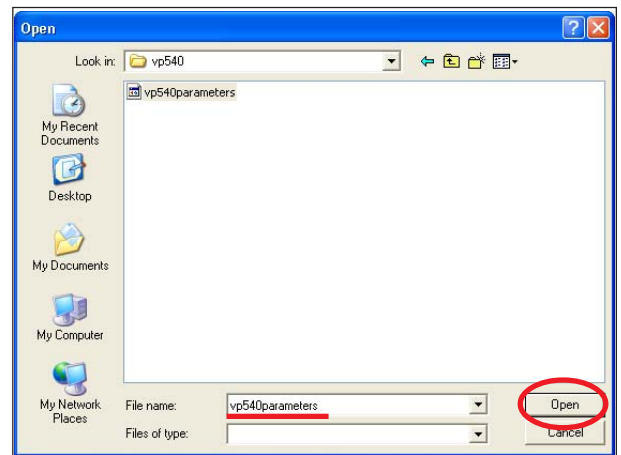

- 14 Click [Get Report] button to import the System Report file.
Confirm that the System Parameter is reloaded properly.



The network settings set at the step 11 are replaced with the ones saved in the System Parameter as [Put Parameters] is executed. Please do the network settings again if necessary.

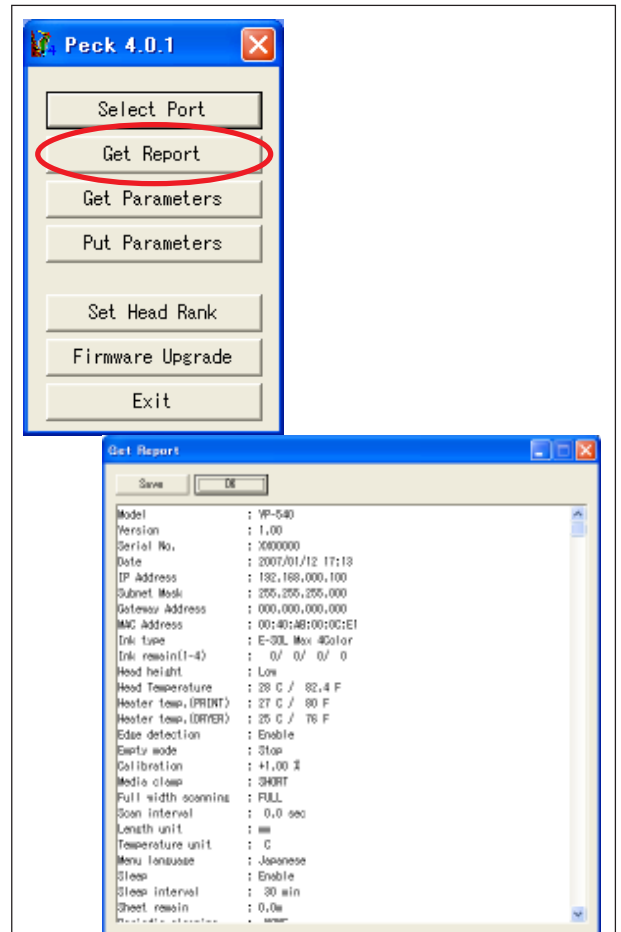

4-3 HOW TO UPGRADE FIRMWARE OF THE NETWORK CONTROLLER (Referential Time : 5min.)

- 1 Turn on the Main Power SW and Sub Power SW, then press [MENU] key.
Select [SYSTEM INFO.]> [NETWORK]> [IP ADDRESS] and set the IP address.



Close the RIP when it is running.

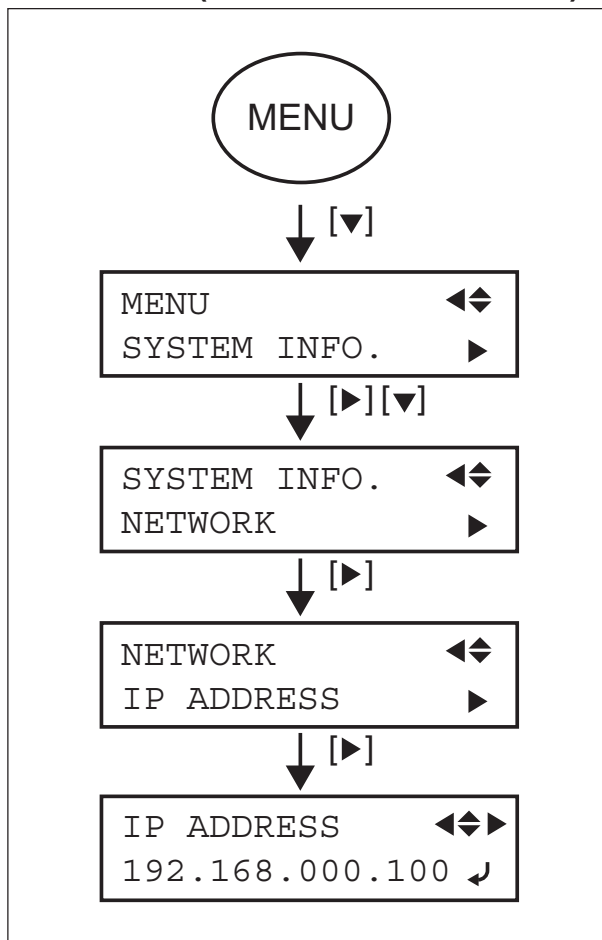

- 2 Open a browser and enter the IP address which is set at step 1.
Current firmware version appears.



Internet Explorer is recommended.

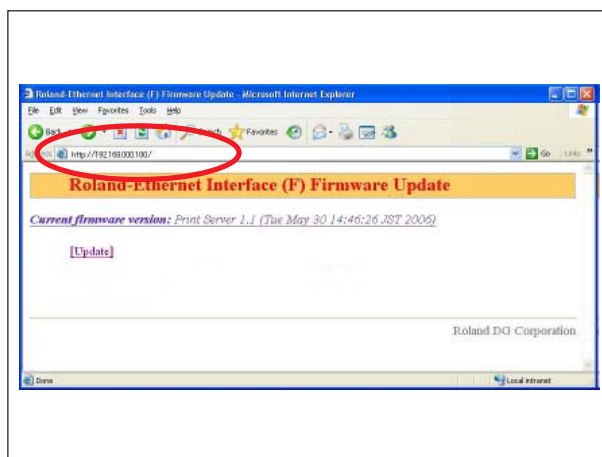

- 3 Click [Update].

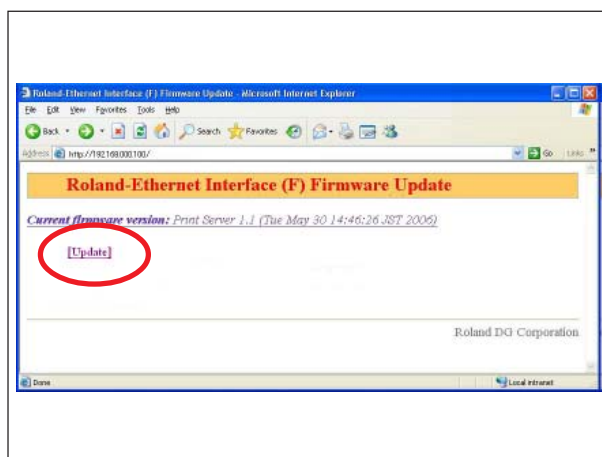

4 Specify the target file for upgrade and click [Update].

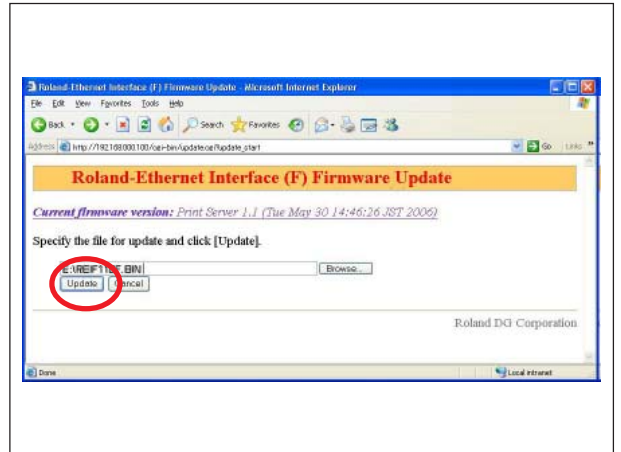

5 The progress is shown in percentage while upgrading.



Do not turn off the power or press any keys while upgrading.

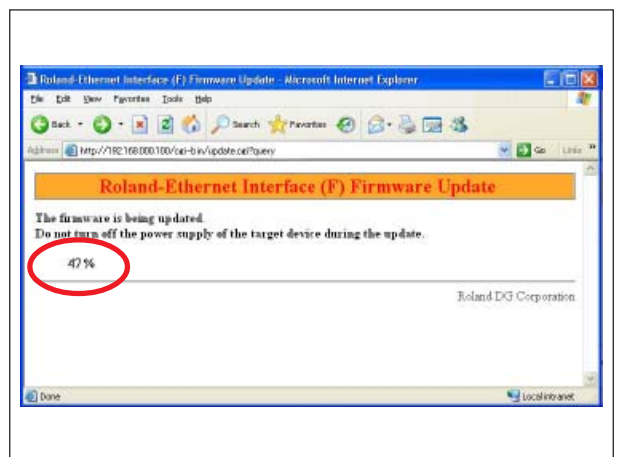

6 When upgrade is completed, the version of upgraded firmware appears.

Turn off the Sub Power SW and Main Power SW once.

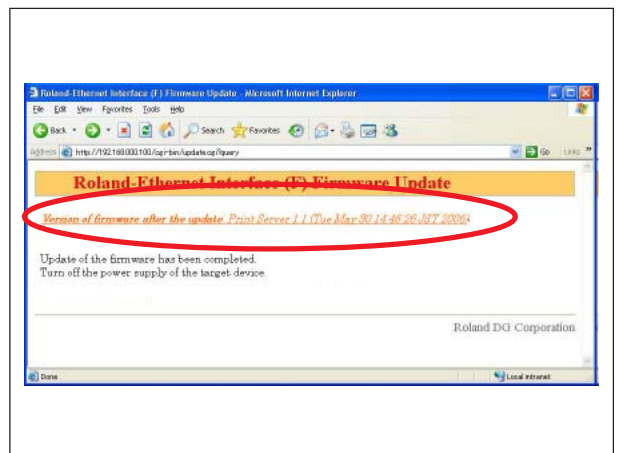

4-4 HEAD ALIGNMENT (Referential Time : 30 min._1 Head Alignment)

This is necessary to obtain the good printing quality. Be sure to operate this alignment when the head is replaced.

If the heads are not aligned, printing problems such as banding, fine lines and gap between bands could occur.

The PET-G is required for this alignment.

Please DO NOT use Take-Up Unit for this alignment.

- 1 Remove the I/S Cover.

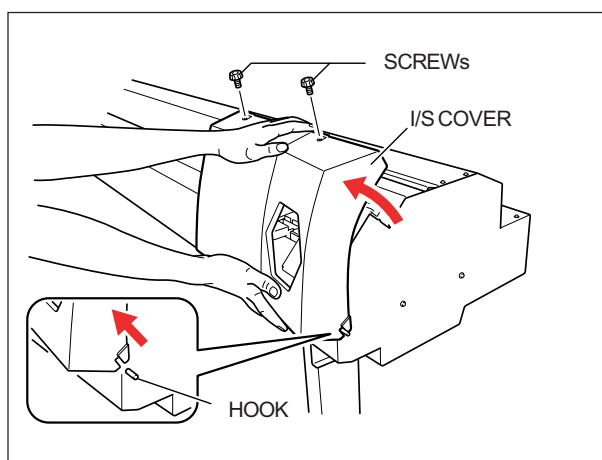

- 2 Remove the Carriage Cover and Right Top Cover.

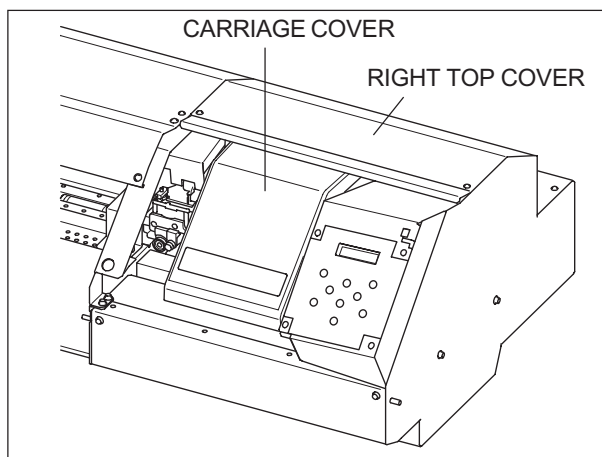

- 3 Remove the Damper Plate.

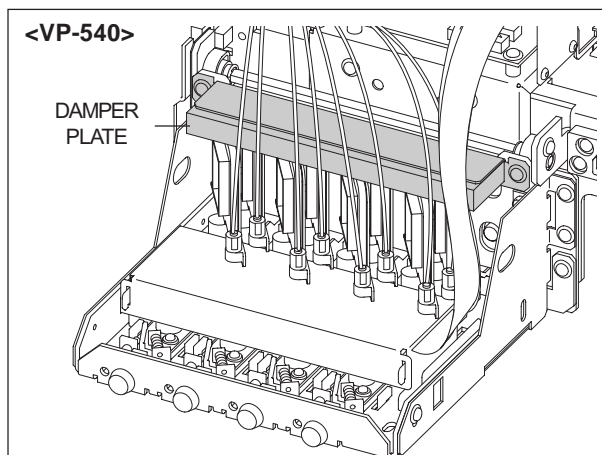

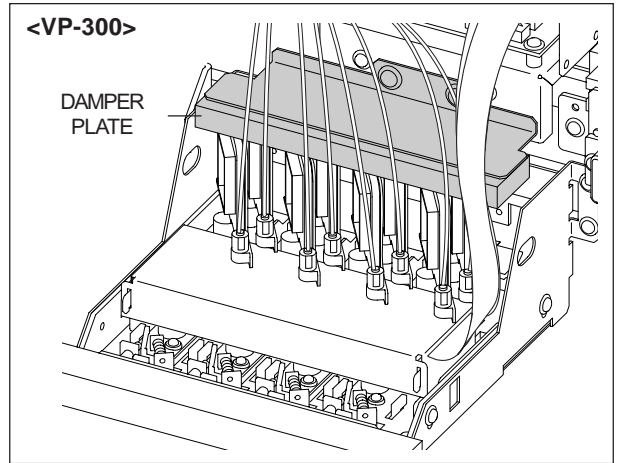

- 4** Turn on the Sub Power SW while pressing [◀], [▼] and [▶] keys to enter the Service Mode.

Set up the PET-G on the machine.

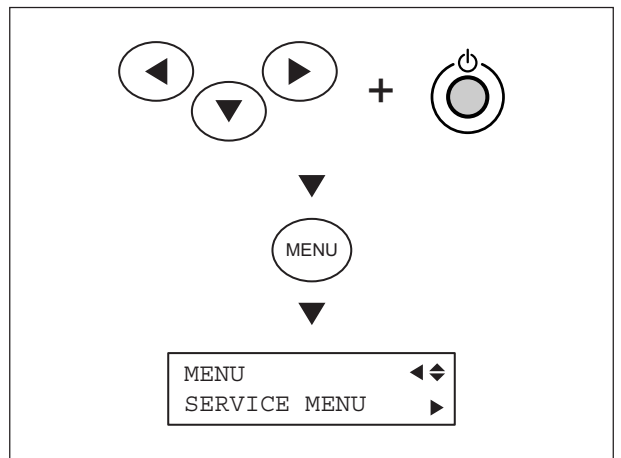

- 5** **[BIAS ADJUSTMENT]**
Select [PRINT MENU]> [HEAD ADJUST]> [BIAS], and press [ENTER] key.

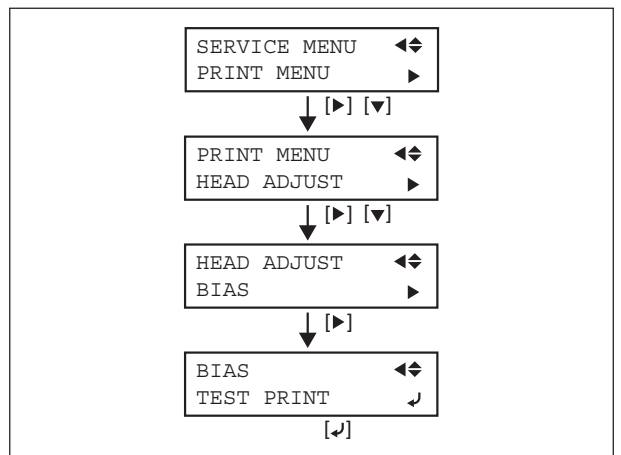

- 6** Test pattern as shown in the figure will be printed.

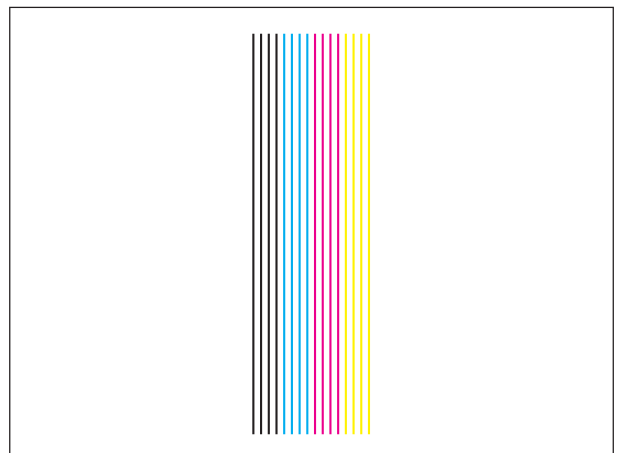

7 Loosen the 3 screws fixing the head.



Loosen the screws fixing the head for 1/2 turn. If the screws are loosened too much, the alignment cannot be done correctly.

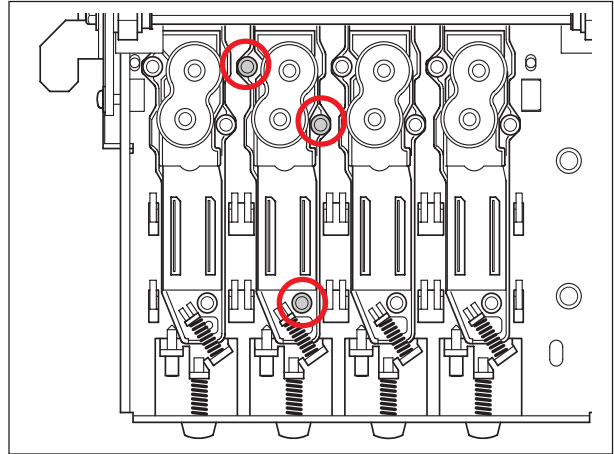

8 Insert the 1.5 mm Hexagonal Wrench through the hole of the Head Carriage, then turn the Adjustment Screw to make the lines of each color in the test pattern straight.



Position of the printing moves 1 line by turning the screw 2/3 turn.

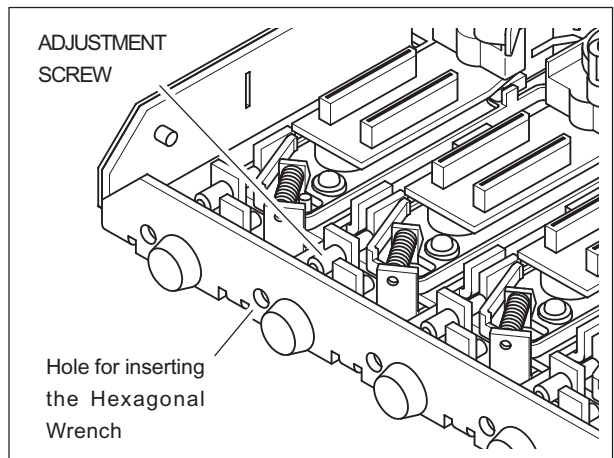

When the upper lines are shifting towards the left of the lower lines, turn the screw CW.

When the upper lines are shifting towards the right of the lower lines, turn the screw CCW.

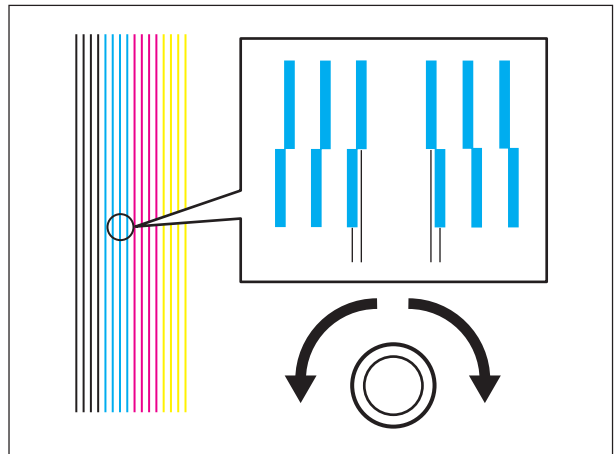

9 Tighten the screws fixing the head in order as shown in the figure, using the Torque Driver (ST-056).



Torque for tightening is **2kgf • cm (20cNm)**. Make sure not to tighten the screws too strong.

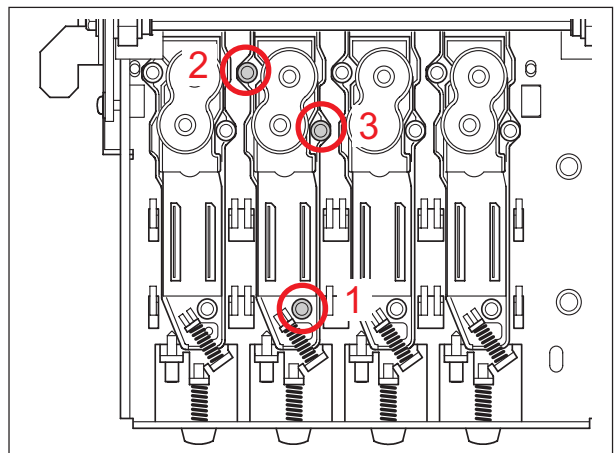

- 10** Print the test pattern again.
If the result is not satisfactory, repeat step 5 to 9.



The shifting of lines should be smaller than 1/2 dot.

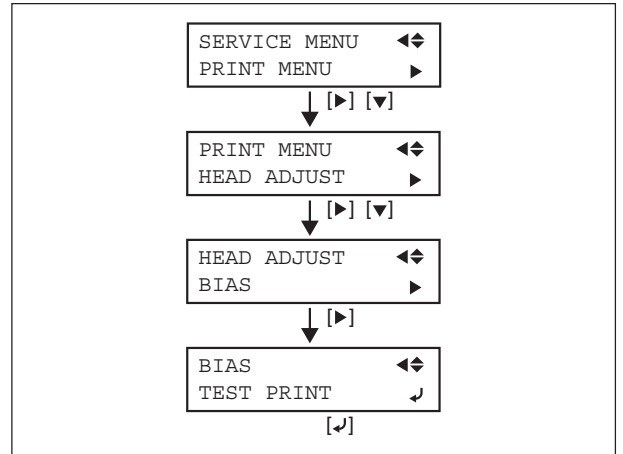

- 11** [VERTICAL ADJUSTMENT]
Select [PRINT MENU]> [HEAD ADJUST]> [VERTICAL]> [TEST PRINT], and press [ENTER] key.

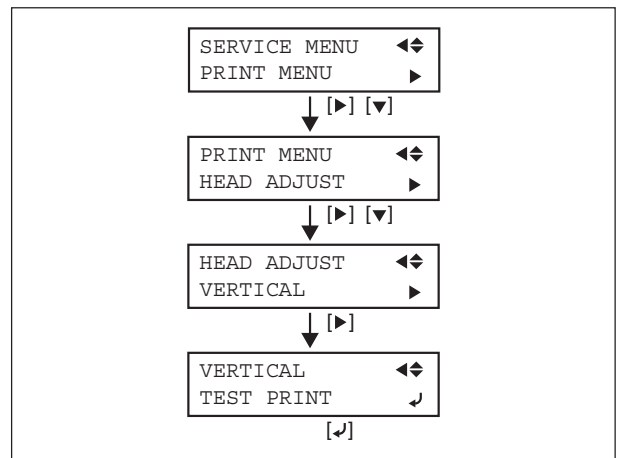

- 12** Test pattern as shown in the figure will be printed.

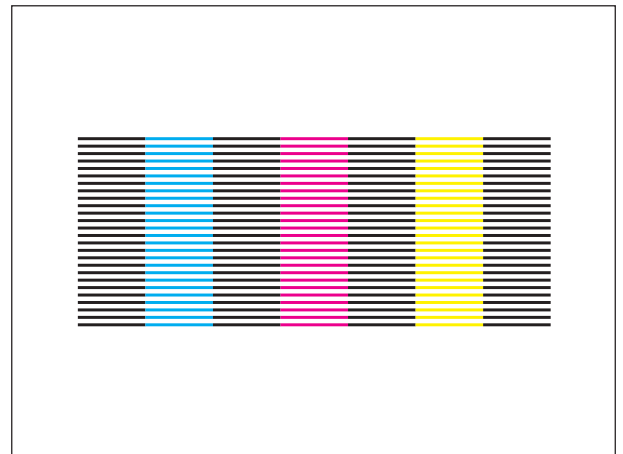

- 13** Loosen the 3 screws fixing the head.



Loosen the screws fixing the head for 1/2 turn.
If the screws are loosened too much, the alignment cannot be done correctly.

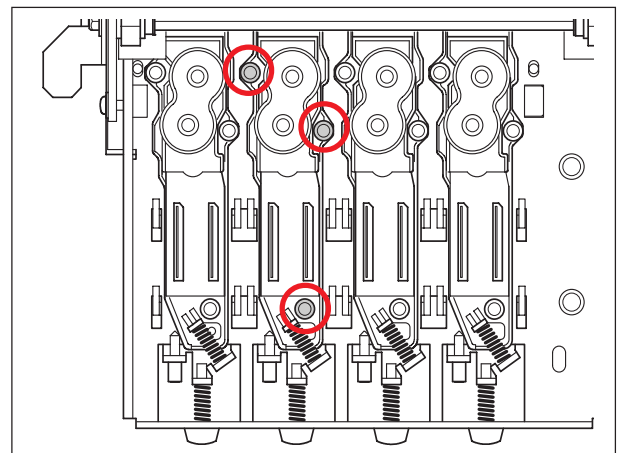

14 Turn the Adjustment Screw to make the lines of each color in the test pattern straight.



Position of the printing moves 1 line by turning the screw 1/6 turn.

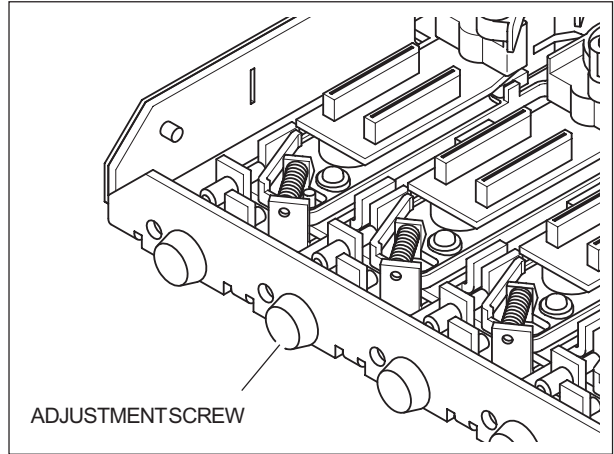

When the lines other than K are above the K lines, turn the Adjustment Screw CW.

When the lines other than K are below the K lines, turn the Adjustment Screw CCW.



Adjust the head positions referring to the left-end K head as the base position. The position of K head on the left end does not need to be adjusted.

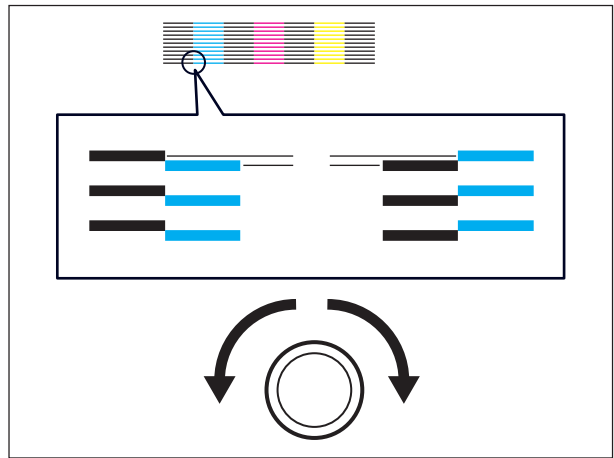

15 Tighten the screws fixing the head in order as shown in the figure, using the Torque Driver (ST-056).



Torque for tightening is **2kgf • cm (20cNm)**. Make sure not to tighten the screws too strong.

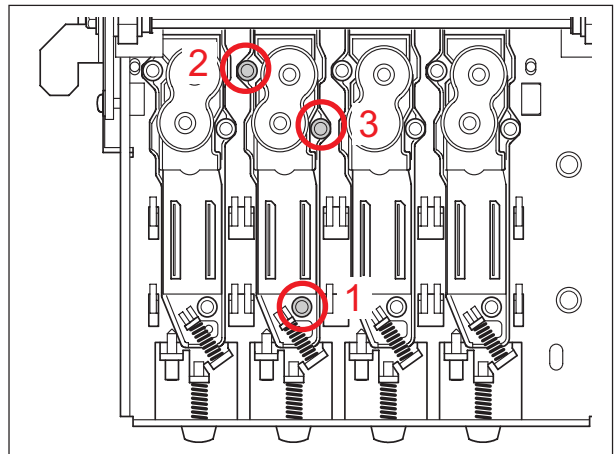

16 Print the test pattern again.
If the result is not satisfactory, repeat step 11 to 15.

If the VERTICAL test print result is satisfactory, select [HEAD ADJUST]> [BIAS]> [TEST PRINT], and print the BIAS test pattern again.

If the BIAS test print result is not satisfactory, repeat BIAS ADJUSTMENT.



The shifting of lines should be smaller than 1/2 dot.

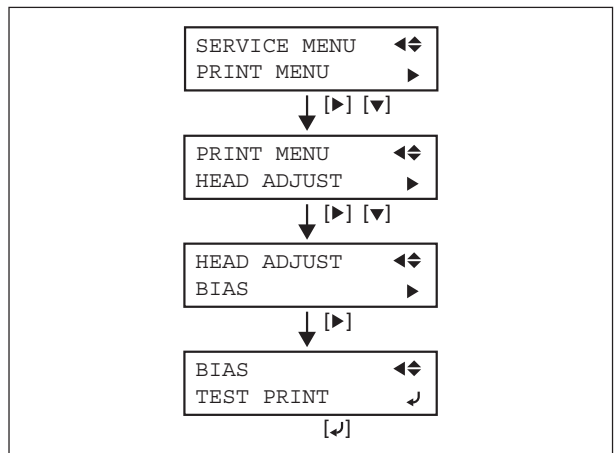

17 [HORIZONTAL ADJUSTMENT]

Select [PRINT MENU]> [HEAD ADJUST]> [HORIZONTAL]> [TEST PRINT], and press [ENTER] key.

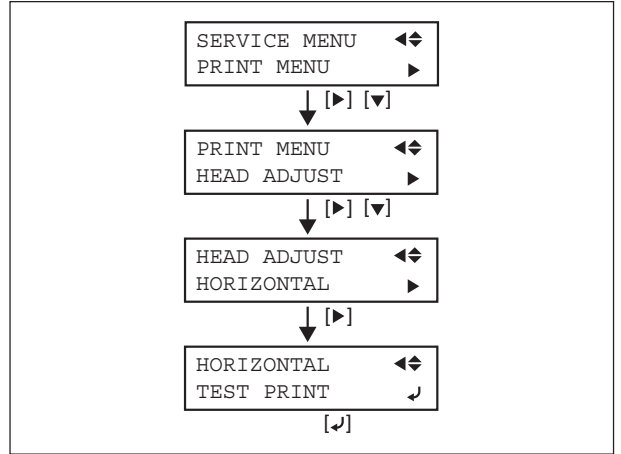

18 Test Pattern will be printed.

Find the position where the line of each color matches the K line and check the number.

In case of having problem selecting one between 2 numbers, 1/2 is also available when setting up the value.

The number with ■ is the current setting.

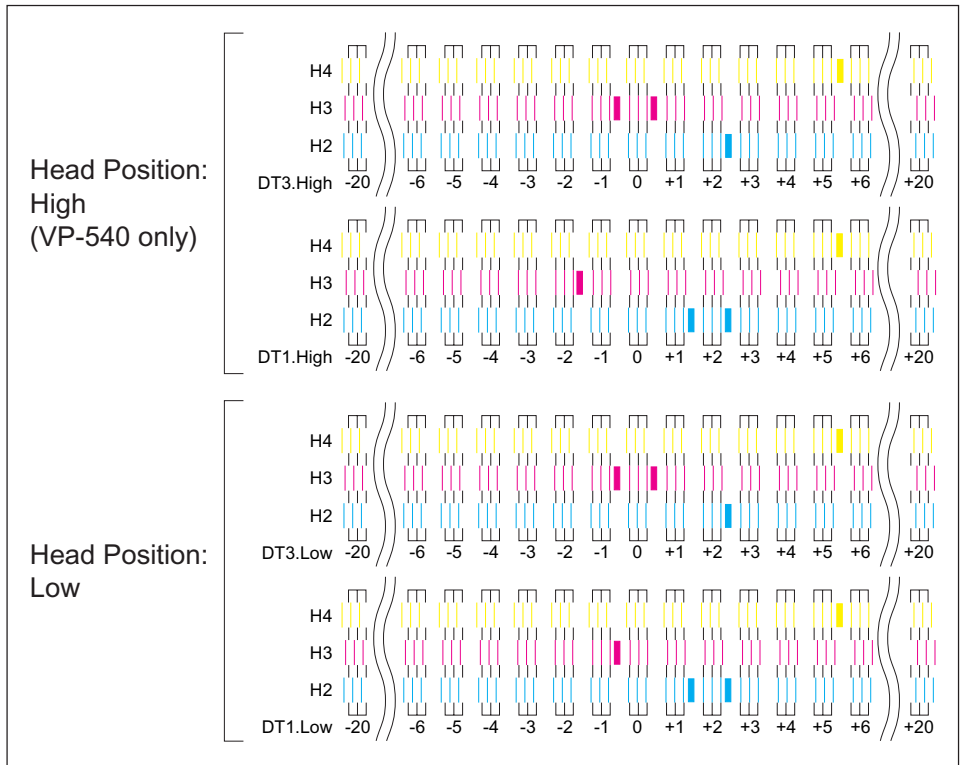

19 Select [DT1, Low], [DT3, Low], [DT1, HIGH] and [DT3, HIGH] in the [HEAD ADJUST] menu and enter the parameters checked at step 18 with [▲] and [▼] keys. Press [ENTER] key to save the settings.



Parameters can be entered with an increment of 1/2.

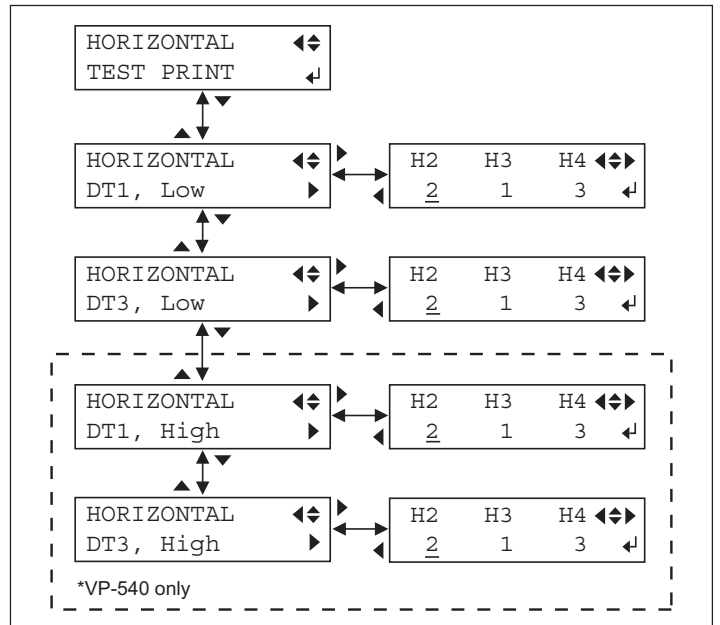

20 [BIDIRECTIONAL ADJUSTMENT]

Select [PRINT MENU]> [HEAD ADJUST]> [BI-DIR.DEFAULT]> [TEST PRINT], and press [ENTER] key.

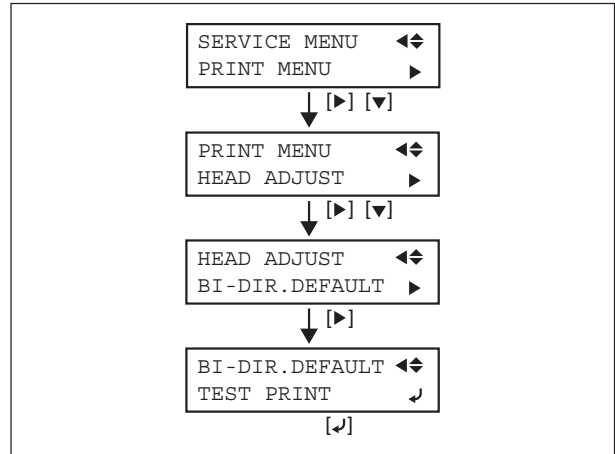

21 Test pattern will be printed.

Find the position where the two lines are overlapping and check the number of each color.

In case of having problem selecting one between two numbers, 1/2 is also available when setting up the value.

The number with ▲ is the current setting.

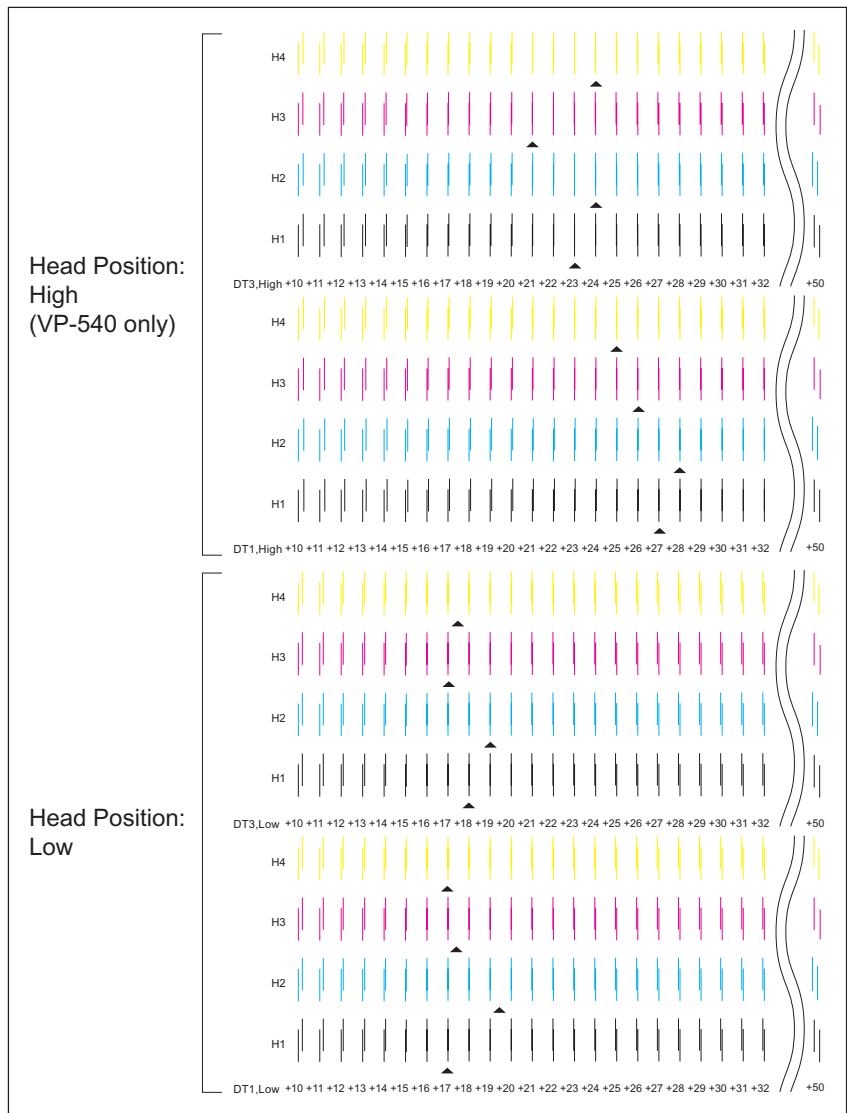

22 Select [DT1, Low], [DT3, Low], [DT1, HIGH] and [DT3, HIGH] in the [HEAD ADJUST] menu and enter the parameters checked at step 21 with [▲] and [▼] keys. Press [ENTER] key to save the settings.



Parameters can be entered with an increment of 1/2.

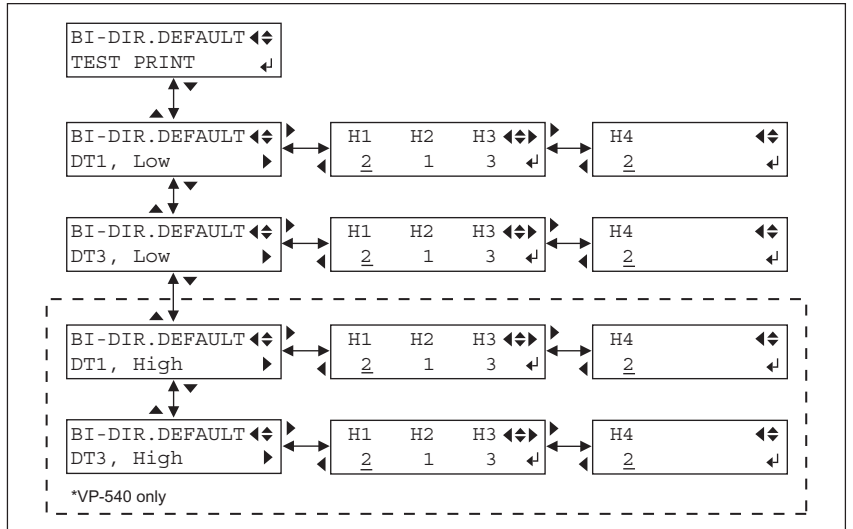

23 Fix the Damper Plate.



Make sure to press the Damper Plate downward lightly when fixing it. If you press the Damper Plate strongly, the Damper may be damaged.

* Fix the screws at the lower end of the long screw hole.

<VP-540>

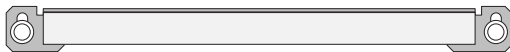

<VP-300>

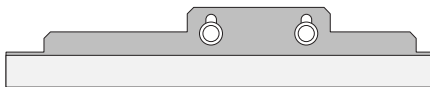

<VP-540>

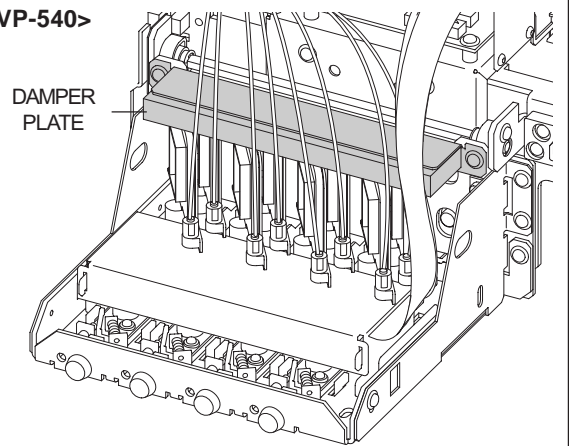

<VP-300>

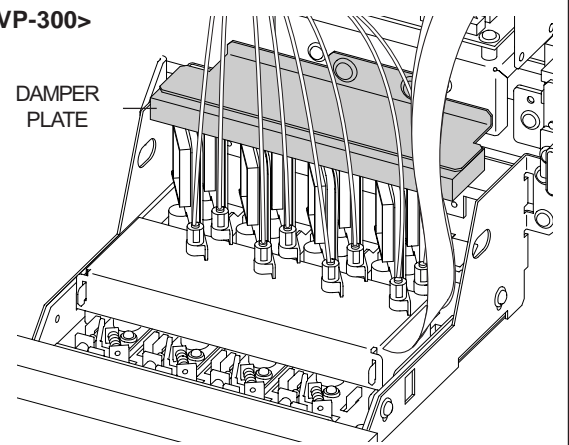

4-5 LIMIT POSITION & CUT DOWN POSITION INITIALIZE (Referential Time : 3min.)

This is for adjusting the relative distance between the Limit Sensor and the Capping Position, and also detecting the distance from the Cut Down Position to the Limit Sensor after completing the adjustment. When the Limit Position is not correctly set, it may cause some problems such as a head capping error and a head carriage lock error. Also, when the cutter-down position is not correct, there will be some problems such as a cutter-down error when separating the sheet. Flushing Position Adjustment is required after this adjustment. Revised 1

- 1** Remove the I/S Cover.

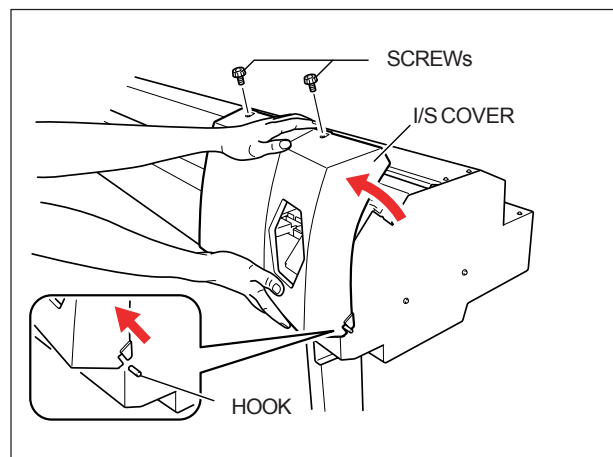

- 2** Turn on the Sub Power SW while pressing [◀], [▲] and [▶] keys to enter the Limit Initialize mode.

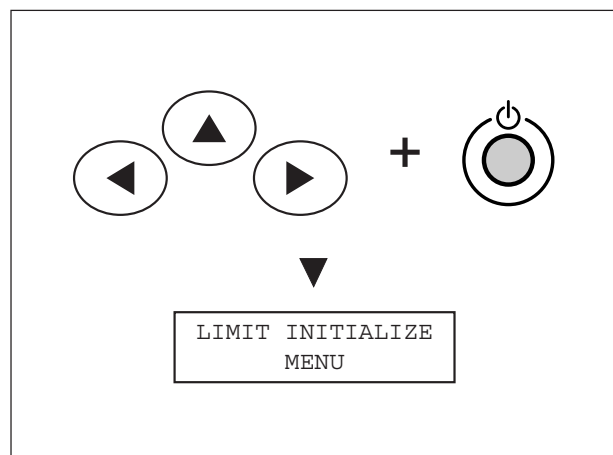

- 3** Confirm that the Head Carriage is connected to Tool Carriage. Also, lock the connected carriages if they are not locked.



After locking the carriages, push them lightly towards left to confirm it is locked and also to eliminate looseness.

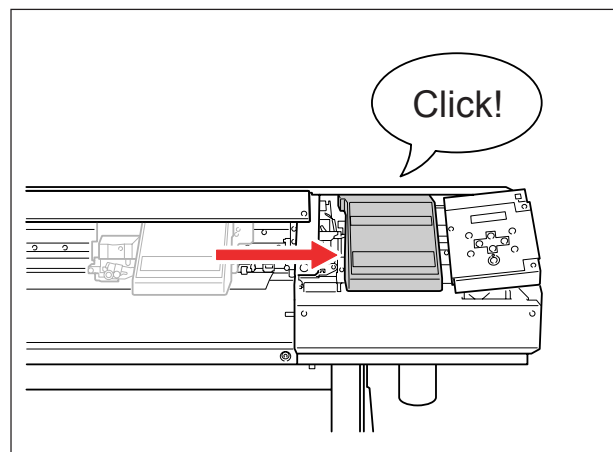

- 4 Confirm that the head is certainly capped, and press [ENTER] key. The Tool Carriage gets separated from the Head Carriage and it starts limit position initialize. After the completion of the initialize, the message is displayed as shown in the figure.

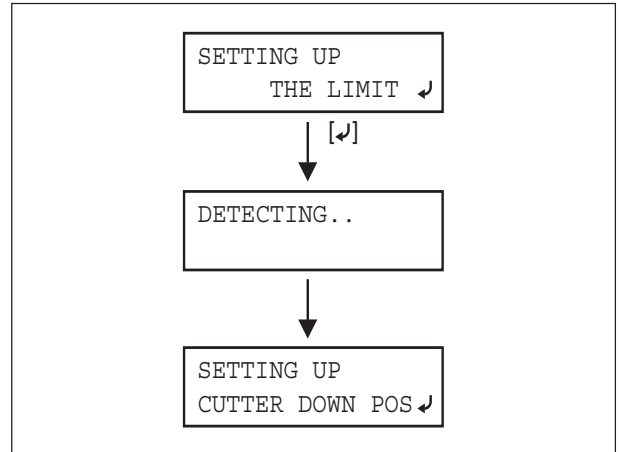

- 5 Move the Tool Carriage with your hand until it makes full contact with the Left Frame with Cut Down status.

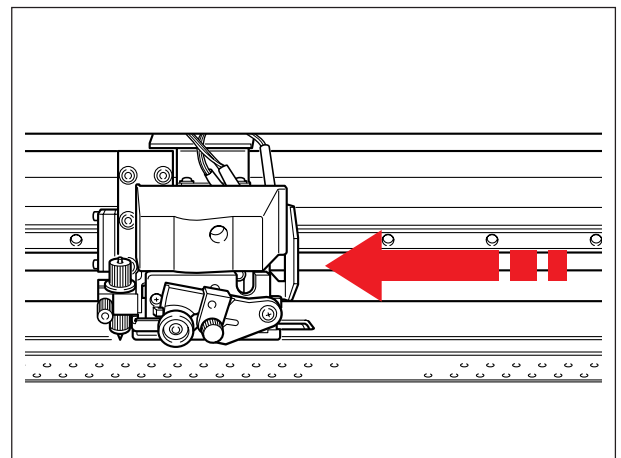

- 6 Perform the Cut Down Position Initialize by pressing [ENTER] key. After the completion of the initialize, the message is displayed as shown in the figure.

- Revised 1 Perform the following adjustment.
[4-7 FLUSHING POSITION ADJUSTMENT]

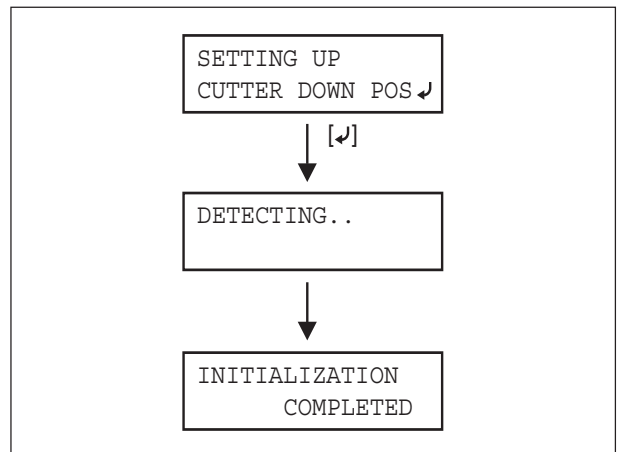

4-6 LINEAR ENCODER SETUP (Referential Time : 5min.)

This is for checking the reading of the linear encoder and for calibrating its expansion/contraction caused by the operation environment. This operation is required when Limit Sensor, Encoder Scale or Encoder Module is replaced or the position is adjusted.

- 1 Turn on the Sub Power SW while pressing [◀], [▼] and [▶] keys to enter the Service Mode.

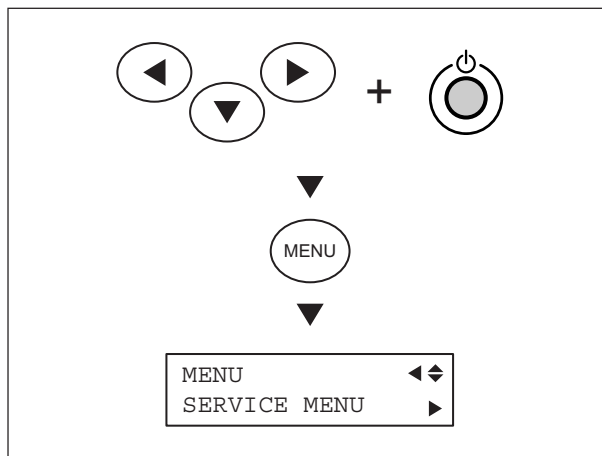

- 2 Lower the Pinch Rollers.
Make sure to unload the media when it is set on the machine.
Also, the Media Clamps must be removed.

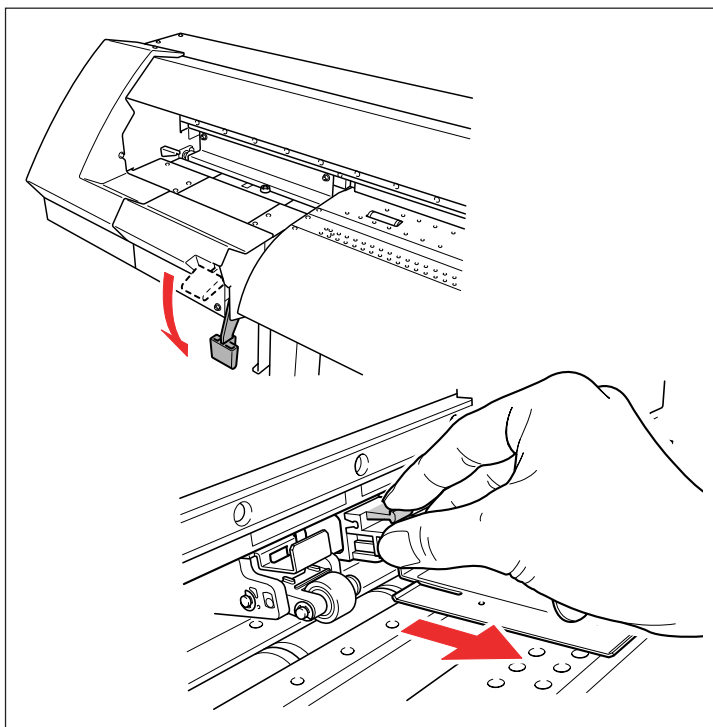

- 3 Select [PRINT MENU]> [LINEAR ENCODER], and press [ENTER] key.

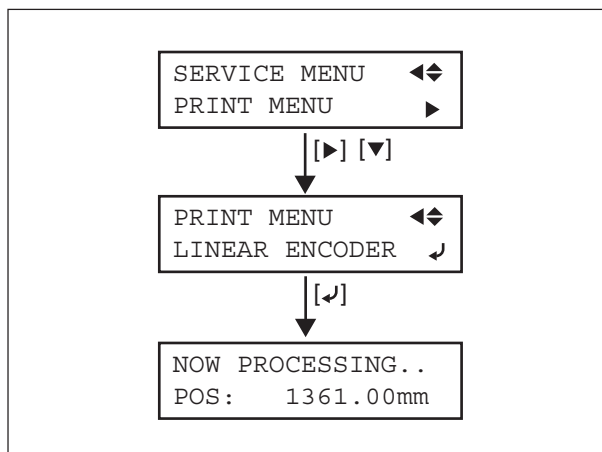

- 4** One of the messages appears at the completion of the set up. In case of Setup error, check the followings.

- Dirt/Scratch on the Encoder Scale.
- Dirt/Scratch on the Encoder Module.
- Encoder Scale is not between the Encoder Module.
- Backlash of the Carriage Motor Gear and the Drive Gear.
- Fixation between the Carriage and the Carriage Belt.
- Bad Contact in the cables.

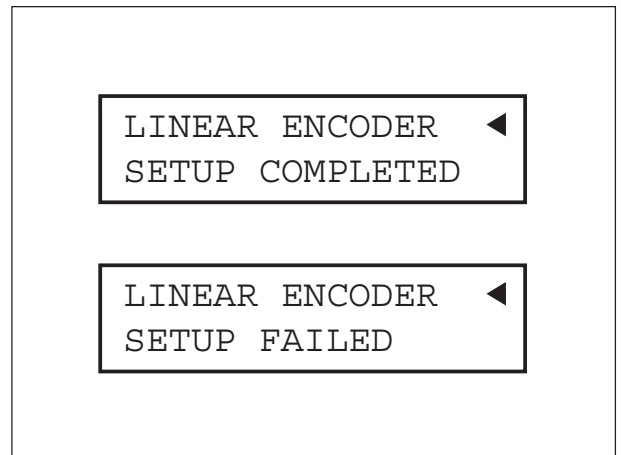

- 5** When LINEAR ENCODER SETUP is completed, perform the [LINEAR CALIB.] in the Service Menu.

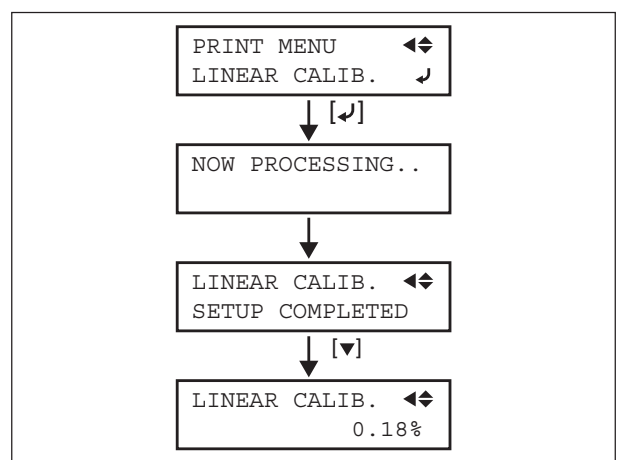

- 6** In case of an error, check the followings.

- Dirt/Scratch on the Encoder Scale.
- Dirt/Scratch on the Encoder Module.
- Encoder Scale is not between the Encoder Module.
- Backlash of the Carriage Motor Gear and the Drive Gear.
- Fixation between the Carriage and the Carriage Belt.
- Bad Contact in the cables.

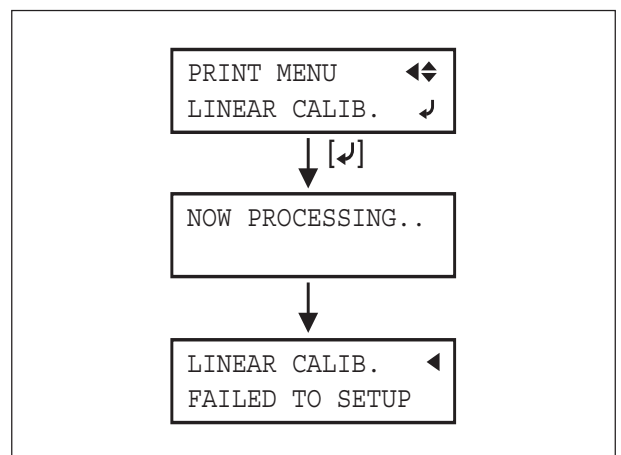

4-7 FLUSHING POSITION ADJUSTMENT (Referential Time : 5min.)

This is to adjust the flushing position. This adjustment is required when a Cap Top and a head are removed or replaced. Without this adjustment, the Flushing may not be performed properly.

- 1 For VP-540, the Head height should be set LOW.

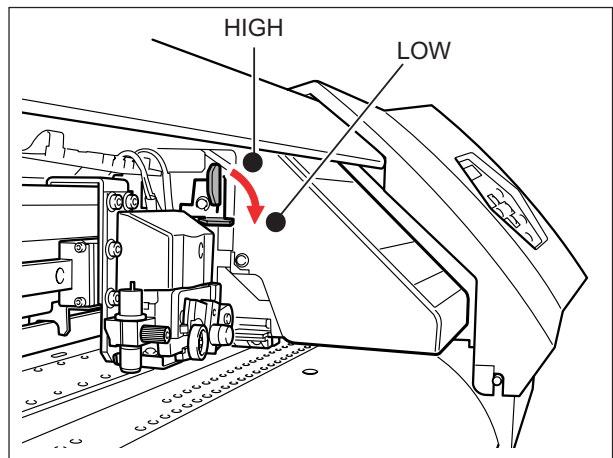

- 2 Remove the I/S Cover.

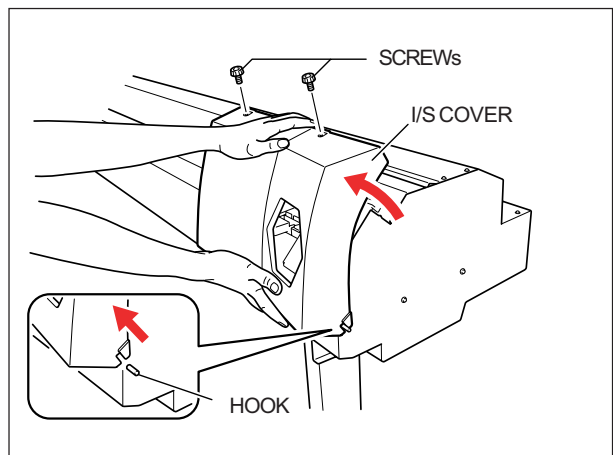

- 3 Turn on the Sub Power SW while pressing [◀], [▼] and [▶] keys to enter the Service Mode.

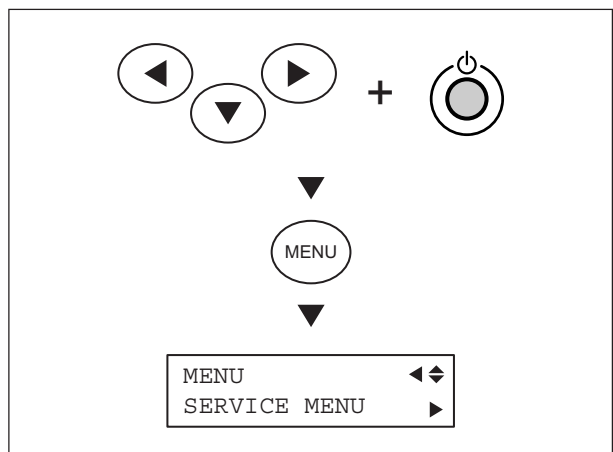

- 4** Select [PRINT MENU]> [FLUSHING ADJ.], and press [ENTER] key.

The Head Carriage automatically moves to the current flushing position.

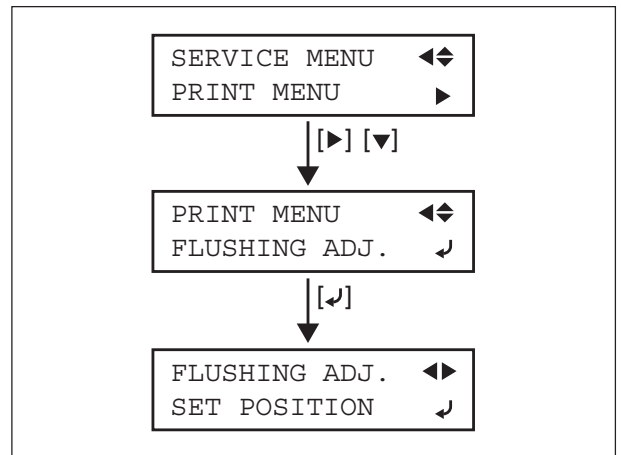

- 5** Move the Cap Tops and heads to the position where the leftmost Cap Top makes contact with the surface of the leftmost head by pressing [◀] and [▶] keys. Then, press [ENTER] key to update the flushing position.

When you press [MENU] key, the flushing position is not updated and exiting the menu.

Revised 1



The left end cap does not necessarily touch first.

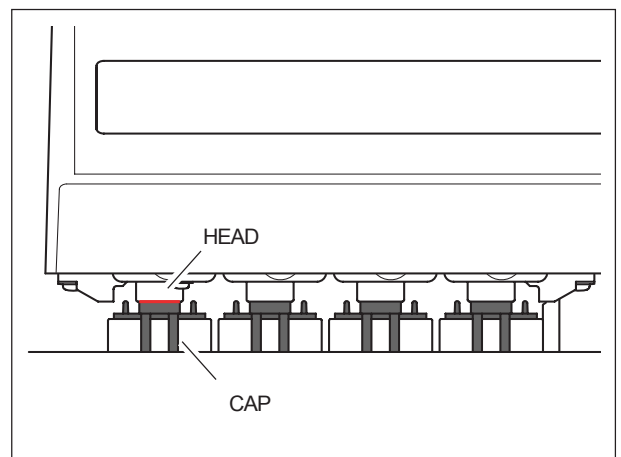

4-8 CROP MARK SENSOR ADJUSTMENT (Referential Time : 10min.)

This adjustment is for adjusting the sensitivity of the Crop Mark Sensor. If not adjusted, the crop marks cannot be read correctly and it results in an error of cut position to the print. This adjustment is required under following cases.

- Crop Mark Sensor or Tool Carriage Board is replaced or adjusted.
- The VR for adjusting the voltage is unexpectedly moved.
- The distance between Crop Mark Sensor and the bed surface is changed.

When it needs to be adjusted for a particular media, use the media instead of SV-GG. However, in this case, the adjustment is to be optimized for the media and it may affect the crop mark detection on other media. The result of the crop mark recognition on Roland media is not assured, when any media other than SV-GG is used for this adjustment.

The Print Heater and Dryer must be off during this adjustment.

1 Remove the Covers in order.

1. I/S Cover
2. Maintenance Cover
3. Left Cover
4. Front Cover
5. Top Cover

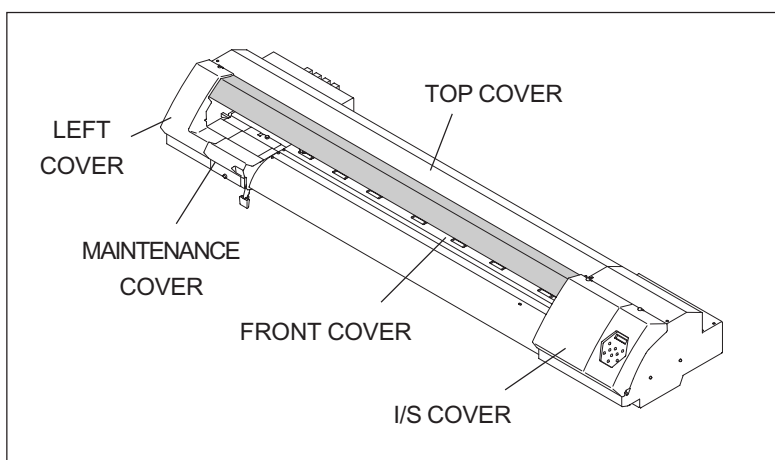

2 Remove the Tool Carriage Cover and Tool Carriage Board Cover.

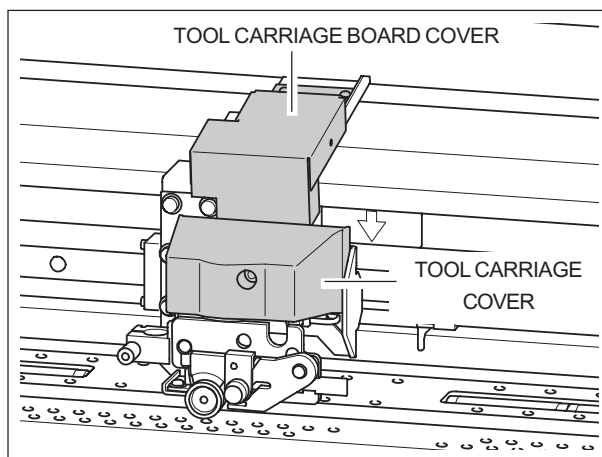

3 Turn on the Sub Power SW while pressing [◀], [▼] and [▶] keys to enter the Service Mode.

Setup the SV-GG on the machine.

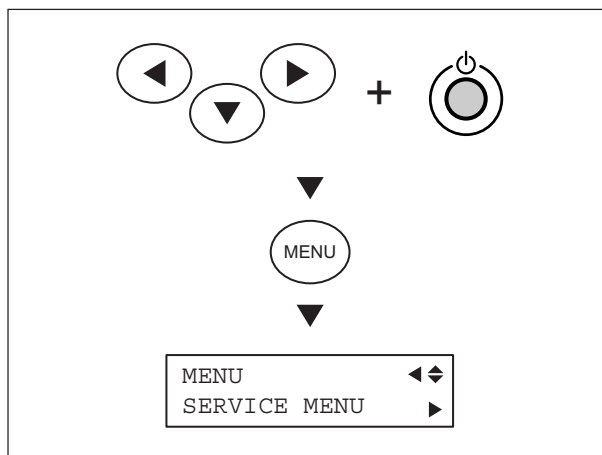

- 4** Select [CUTTING MENU]> [CROPMARK SENS]> [OUTLEVEL CHECK], and press [ENTER] key.
A Crop Mark will be printed.

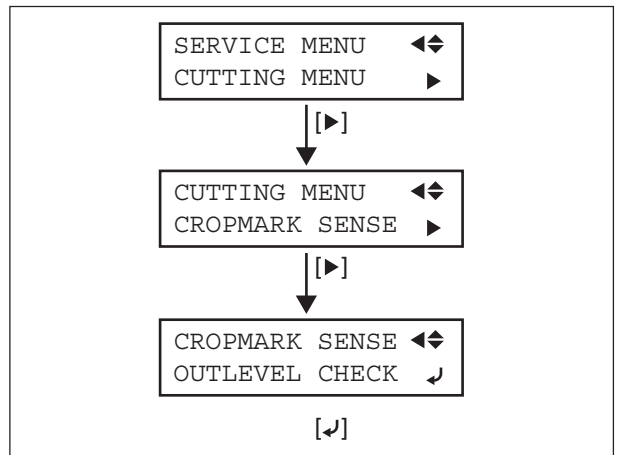

- 5** After printing a Crop Mark, the Tool Carriage moves to above the Crop Mark automatically.
Adjustment is unnecessary when the displayed MAX voltage is 2.7 +/-0.2V.

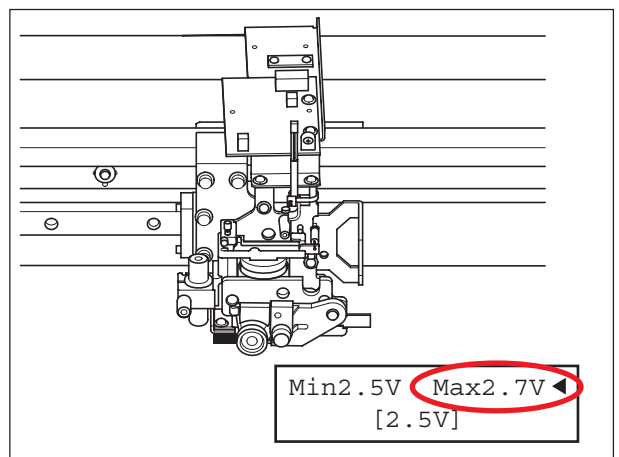

- 6** When the MAX voltage is not proper, see the voltage displayed with [] on the lower LCD. Adjust the VR on the Tool Carriage Board so that the voltage with [] changes to 2.7 +/-0.2V.



Due to the ink dry, the voltage displayed with [] decreases in time. This adjustment needs to be done quickly for smooth operation.

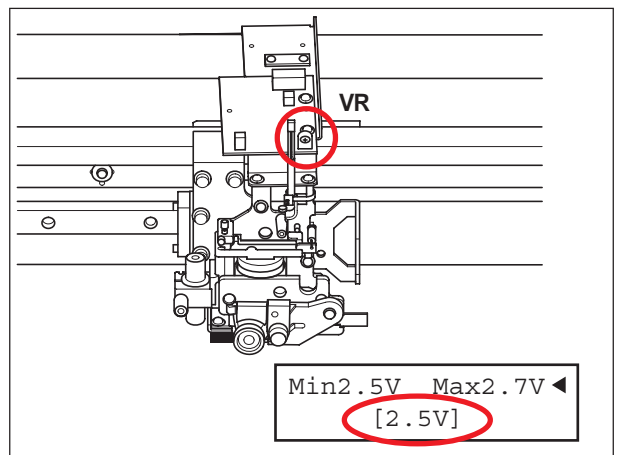

- 7** Perform [OUTLEVEL CHECK] again and confirm that the MAX voltage is proper.
If it is out of range, repeat the adjustment.

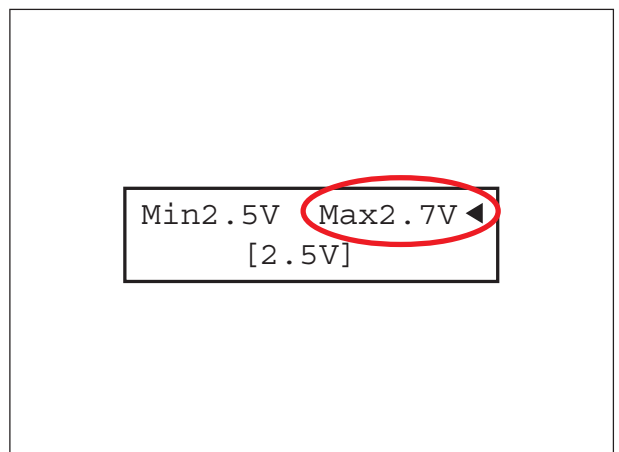

4-9 CROP-CUT ADJUSTMENT (Referential Time : 10min.)

This adjustment is for calibrating the relative positions of Tool and Crop Mark Sensor. If it is not adjusted, the cutting position based on the detected Crop Marks becomes wrong, and that results in the misalignment of the Print and Cut performed under the auto crop mark detection.

This adjustment is required when Crop Mark Sensor or Tool Carriage is replaced.

Before this adjustment, it is necessary to confirm that [ENABLE] is selected for [AUTO ENV. MATCH].

Also, Take-up Unit must not be used during this adjustment.

- 1 Turn on the Sub Power SW while pressing [◀], [▼] and [▶] keys to enter the Service Mode.

Set up media on the machine.



Vinyl media is recommended for this adjustment.

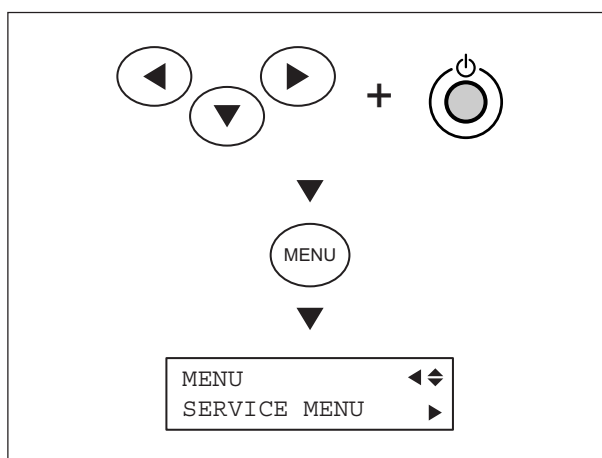

- 2 Perform Bidirectional Adjustment referring to [4-4 HEAD ALIGNMENT].

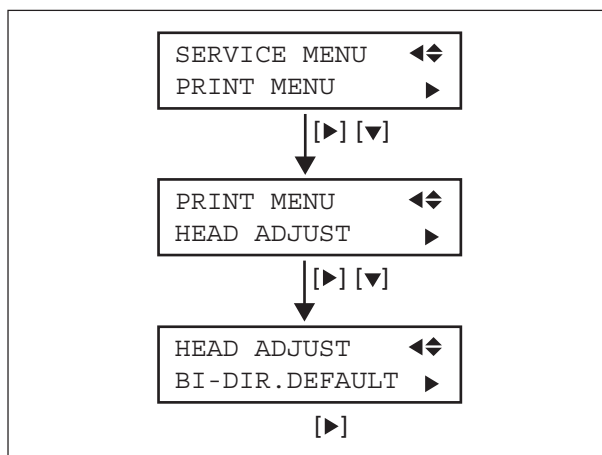

- 3 Select [CUTTING MENU]> [CROP-CUT ADJ.]> [TEST PRINT 2], and press [ENTER] key.

The test print and cut will be performed.



Bidirectional adjustment and this step must be done by using the same media.

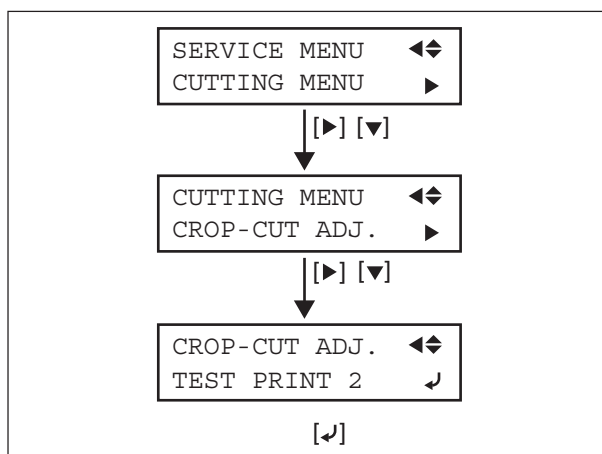

- 4** From the test pattern, find the value where the print line matches the cut line.
In this case, the correction value for the scan direction is "-0.3".



If it is difficult to see the cut line visually, use a magnifier.

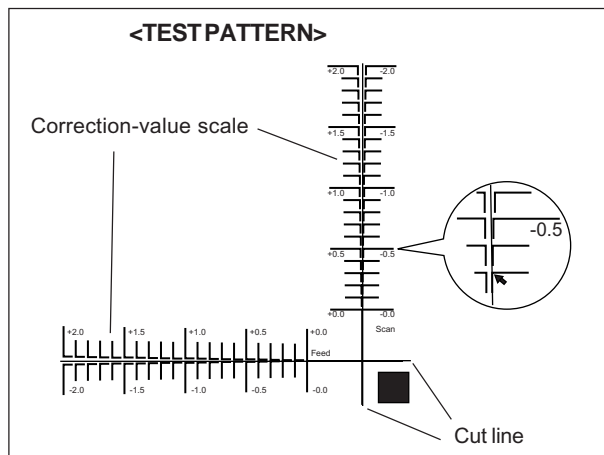

- 5** Select [CUTTING MENU]> [CROP-CUT ADJ.]> [SETTING], and enter the correction-values found in the test pattern for both Feed and Scan.



F: Feed direction S: Scan direction
Left: Current value Right: New value
(Setting range: +/-2.00mm In 0.01mm unit)

▼ key : Value of F, towards +

▲ key : Value of F, towards -

▶ key : Value of S, towards +

◀ key : Value of S, towards -

ENTER key : Saves new setting

MENU key : Moves out SETTING menu

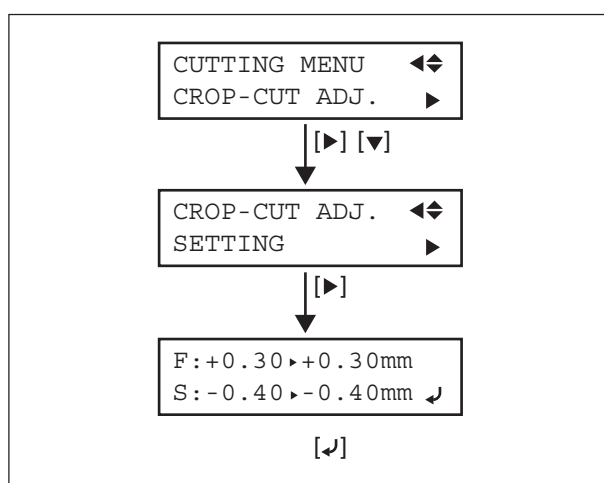

- 6** Select [CUTTING MENU]> [CROP-CUT ADJ.]> [TEST PRINT], and press [ENTER] key.
The test print and cut will be performed.

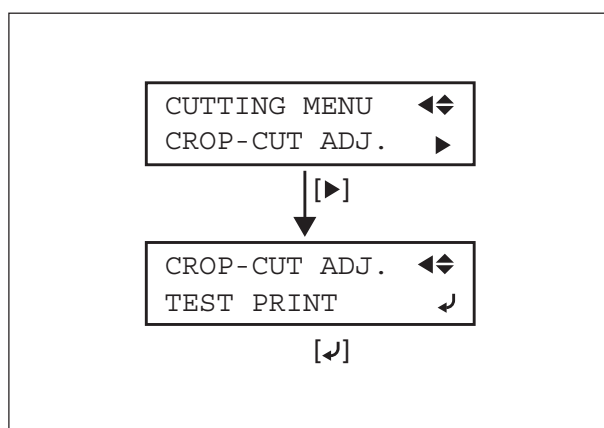

- 7** A Crop Mark is printed, and detected by the Crop Mark Sensor, and its contour is cut. Confirm the cut line position on the print visually.



If it is difficult to see the cut line visually, use a magnifier.

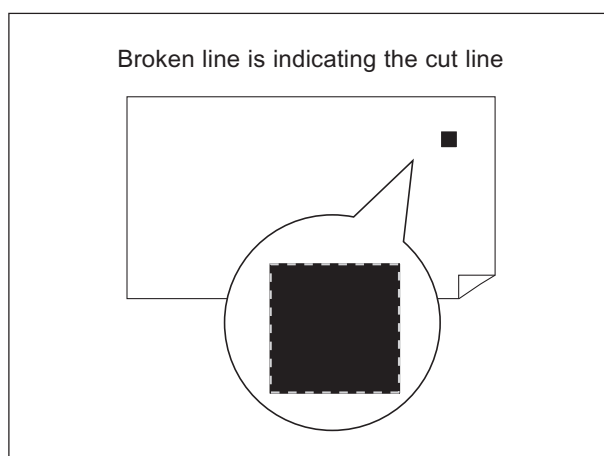

8 Adjustment is completed if the position error of cut line is within +/-0.1mm. If not, select [SETTING] menu again for further adjustment.



- ▼ key : Moves cut position towards front
- ▲ key : Moves cut position towards rear
- ▶ key : Moves cut position towards right
- ◀ key : Moves cut position towards left
- ENTER key : Saves new setting
- MENU key : Moves out SETTING menu

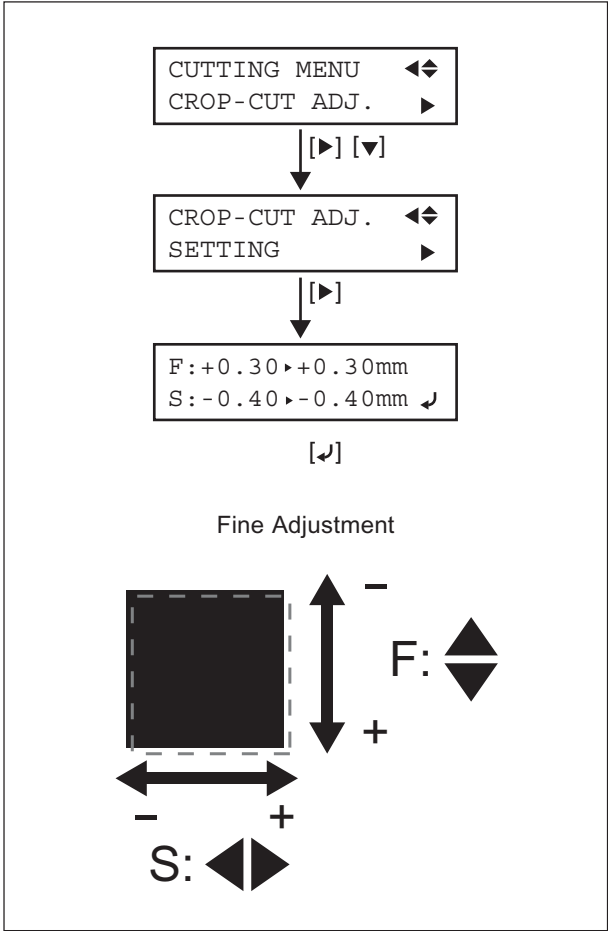

9 Perform the test print again for confirmation. Adjustment is completed if the position of cut line is satisfactory. If not, repeat the adjustment again.

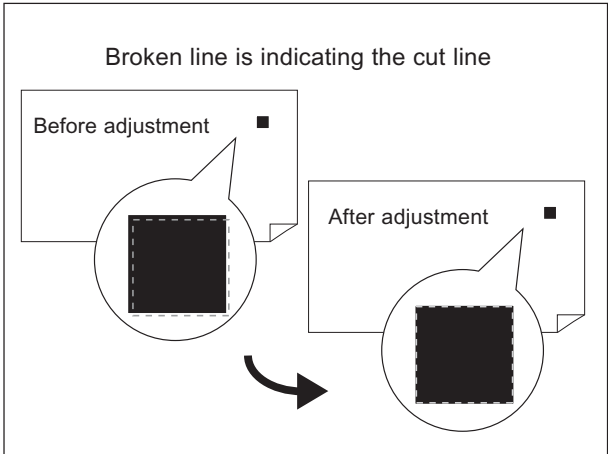

4-10 PRINT / CUT POSITION ADJUSTMENT (Referential Time : 10min.)

This adjustment is for calibrating the relative positions of printing and cutting. If it is not adjusted, it may result in the misalignment of the printing and cutting.

This adjustment is required when Tool Carriage is replaced, or a head is replaced or adjusted, and also when the relative distance between the Carriage and head is changed.

Before this adjustment, it is necessary to confirm that [ENABLE] is selected for [AUTO ENV. MATCH].

Also, Take-up Unit must not be used during this adjustment.

- 1 Turn on the Sub Power SW while pressing [◀], [▼] and [▶] keys to enter the Service Mode.

Set up media on the machine.



Vinyl media is recommended for this adjustment.

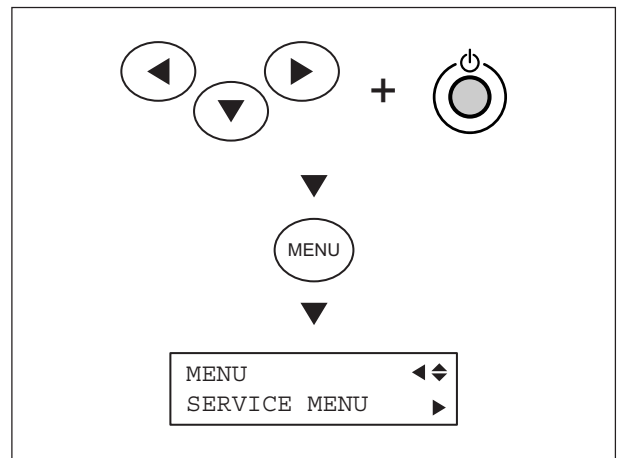

- 2 Perform Bidirectional Adjustment referring to [4-4 HEAD ALIGNMENT].

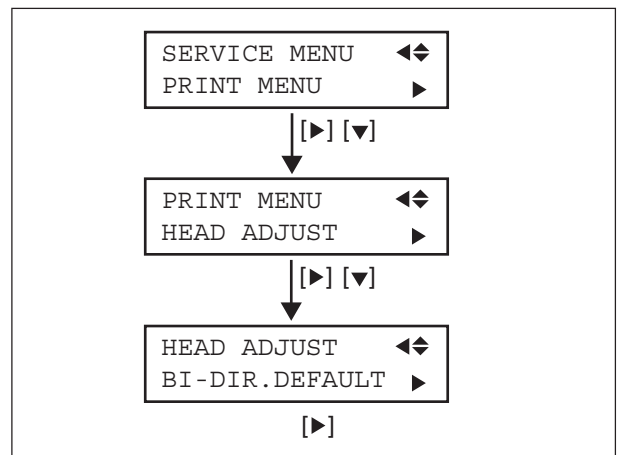

- 3 Select [CUTTING MENU]> [PRINT-CUT ADJ.]> [TEST PRINT 2], and press [ENTER] key. The test print and cut will be performed.



Bidirectional adjustment and this step must be done by using the same media.

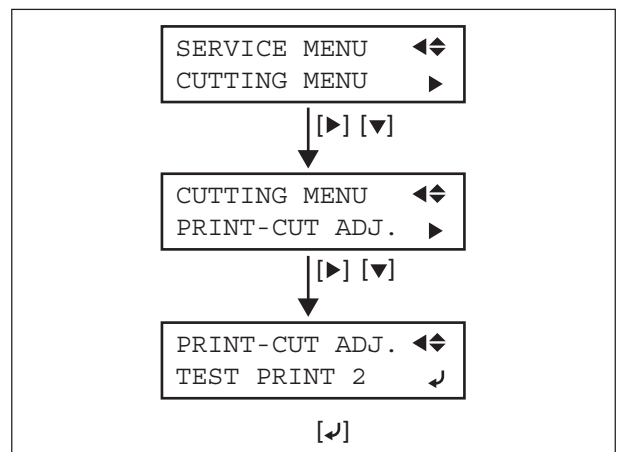

4 From the test pattern, find the value where the print line matches the cut line.

In this case, the correction value for the scan direction is "-0.3".



If it is difficult to see the cut line visually, use a magnifier.

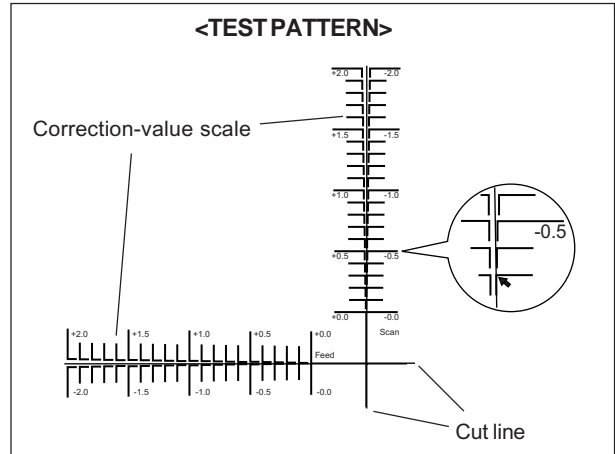

5 Select [CUTTING MENU]> [PRINT-CUT ADJ.]> [SETTING], and enter the correction-values found in the test pattern for both Feed and Scan.



F: Feed direction S: Scan direction
Left: Current value Right: New value
(Setting range: +/-5.00mm In 0.01mm unit)

- ▼ key : Value of F, towards +
- ▲ key : Value of F, towards -
- ▶ key : Value of S, towards +
- ◀ key : Value of S, towards -

ENTER key : Saves new setting
MENU key : Moves out SETTING menu

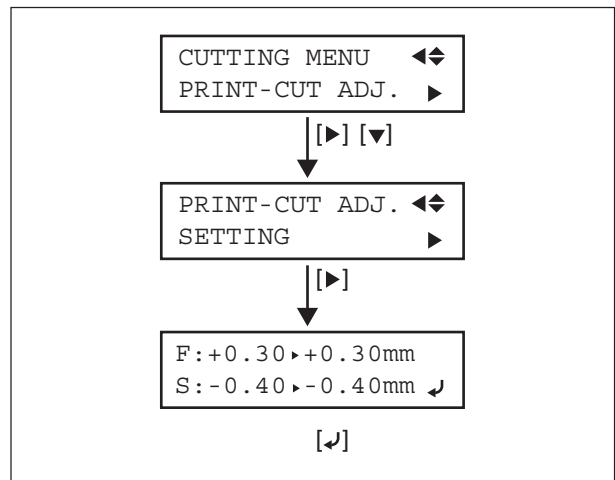

6 Select [PRINT-CUT ADJ.]> [TEST PRINT], and press [ENTER] key.

The test print and cut will be performed.

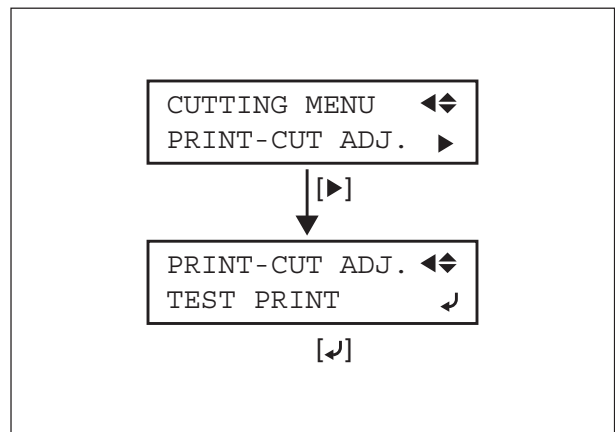

7 3 marks are printed at the left-end, right-end and the center of the media, and each mark is cut. Confirm the cut line positions on the marks visually.



If it is difficult to see the cut line visually, use a magnifier.

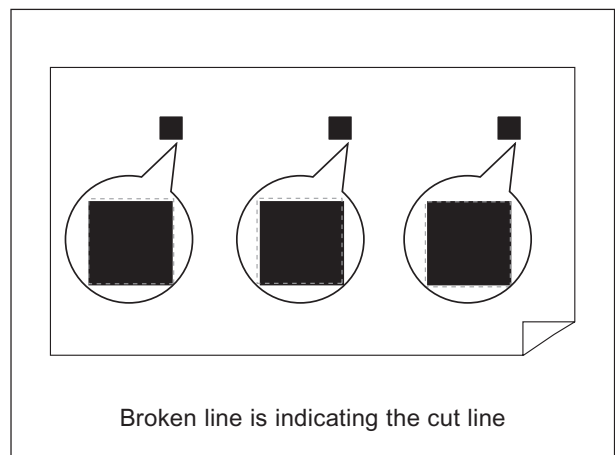

8 Adjustment is completed if the position error of cut line is within the range below. If not, select [SETTING] menu again for further adjustment.

Mark on the right: Within +/-0.1mm

Mark on the left: Within +/-0.3mm

(Make an adjustment based on the mark on the right)



- ▼ key : Moves cut position towards front
- ▲ key : Moves cut position towards rear
- ▶ key : Moves cut position towards right
- ◀ key : Moves cut position towards left
- ENTER key : Saves new setting
- MENU key : Moves out SETTING menu

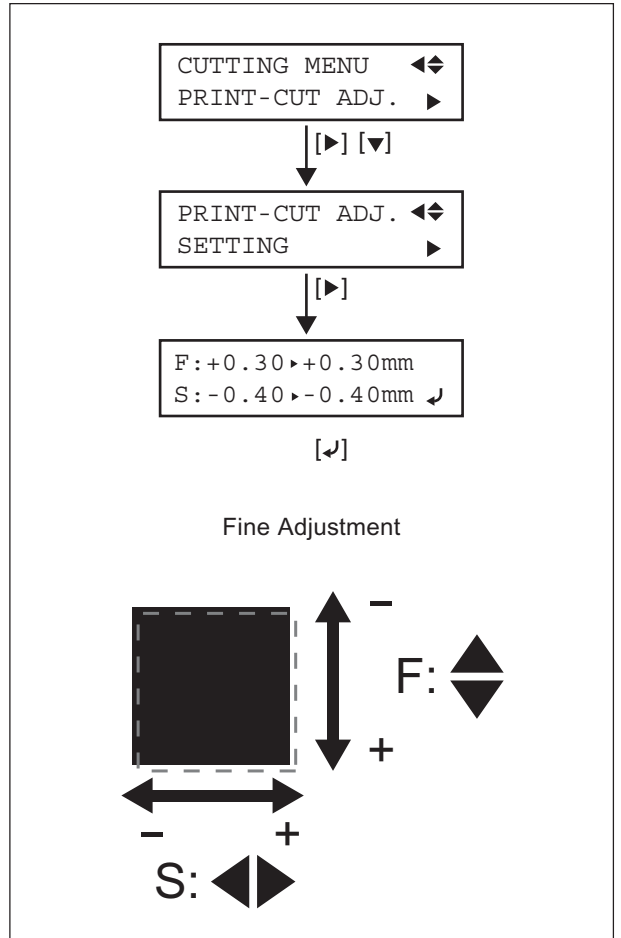

9 Perform the test print again for confirmation. Adjustment is completed if the position of cut line is satisfactory. If not, repeat the adjustment again.

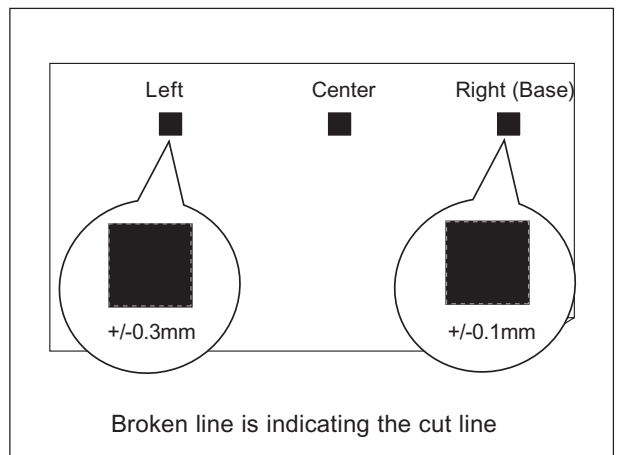

4-11 CALIBRATION (FEEDING DIRECTION) (Referential Time : 20 min.)

This adjustment is for calibrating the feed amount of media. It allows the media to be fed proper amount by calibrating the variation in Grit Roller diameter. Calibration is made based on the value in feeding media [PET-G].

Without proper calibration, it may cause misalignment in the feed amount of media, and it results in the problems such as white banding, banding of overlap or the dimension error of print result compared to the original data.

Take-up Unit must not be used during this adjustment.

- 1 Turn on the Sub Power SW while pressing [◀], [▼] and [▶] keys to enter the Service Mode.

Setup the PET-G on the machine.

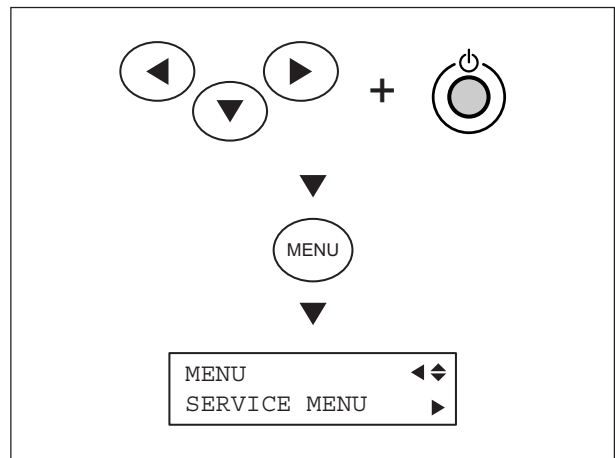

- 2 Select [PRINT MENU]> [CALIB.DEFAULT]> [TEST PRINT], and press [ENTER] key.

Test Pattern will be printed.



Test print requires 510mm or more of the media setup width.

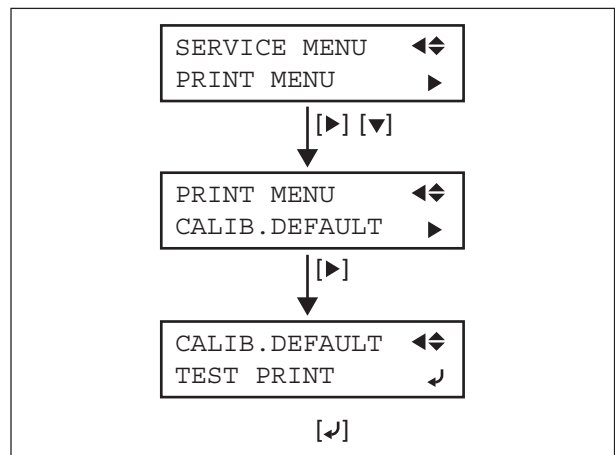

- 3 Measure the length of the feed direction and use the value to calculate the calibration amount with the formula shown at step 4.



Test pattern is always printed with offset 0.00%. Even if a correction is made in the [SETTING] menu, the test pattern is not changed.

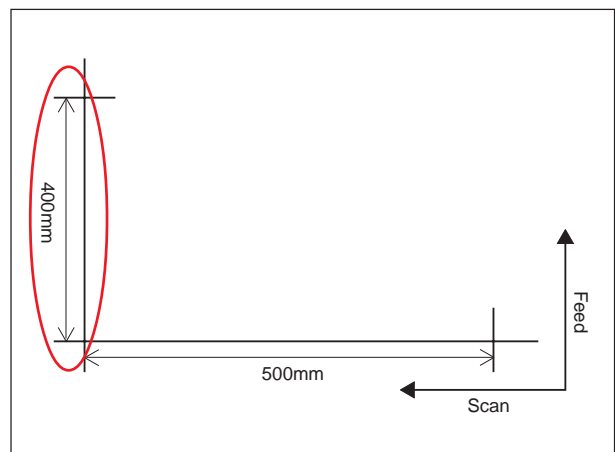

- 4 Calculate the amount to be calibrated with the formula as shown in the figure.

$$\text{Calibration Value} = \frac{400 - \text{Measured Length}}{\text{Measured Length}} \times 100$$

- 5 Select [PRINT MENU]> [CALIB.DEFAULT]> [SETTING], and enter the calibration value with [▲] and [▼] keys. Press [ENTER] key to save the setting.



Parameters can be entered with an increment of 0.01%.
(MAX. +2.00% to MIN. -2.00%)

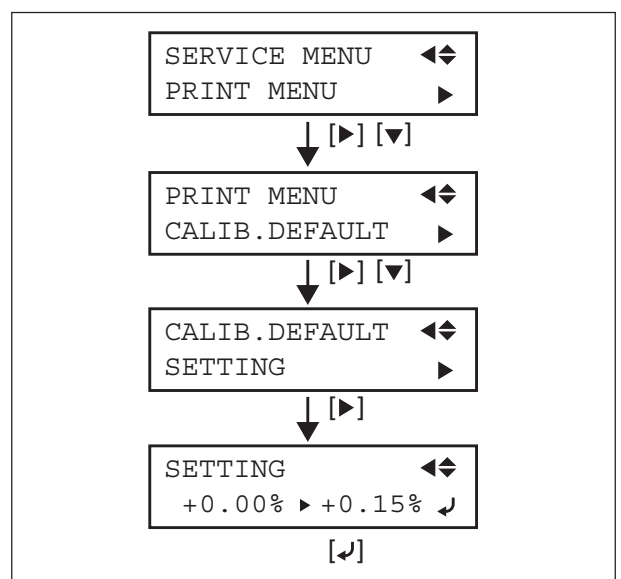

4-12 TOOL HEIGHT ADJUSTMENT (Referential Time : 5min.)

- 1 Install the White Dummy Pen (ST-006) to the Tool Carriage.

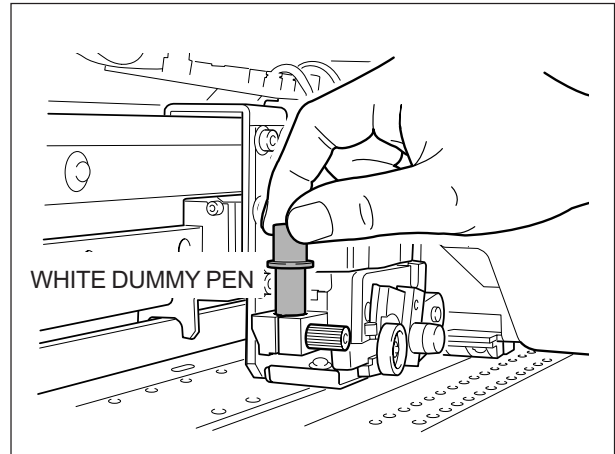

- 2 Move the Pinch Rollers at the positions as shown in the figure, and lower them.

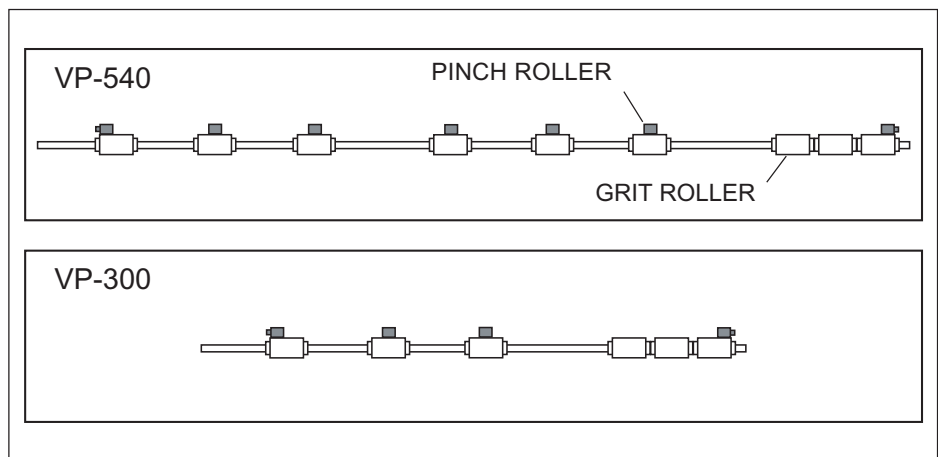

- 3 Remove the I/S Cover.

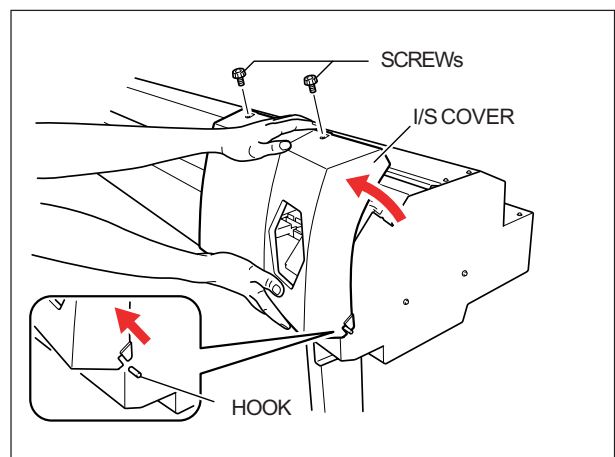

- 4 Remove the Tool Carriage Cover.

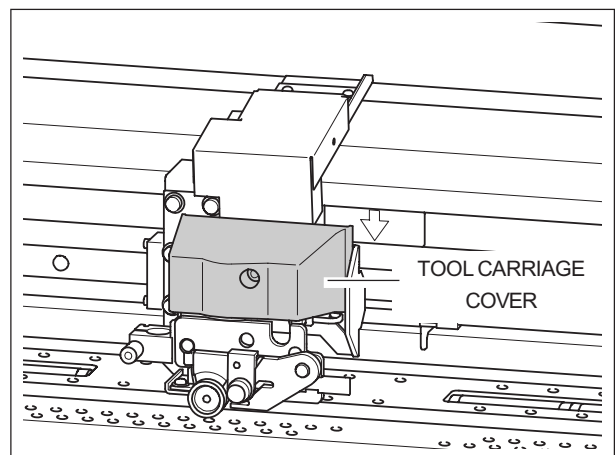

- 5** Move the Head Carriage to the highest position of the bed.
Confirm that Head Carriage is connected to Tool Carriage and lock the connected carriages.



The right end is the highest position of the bed.

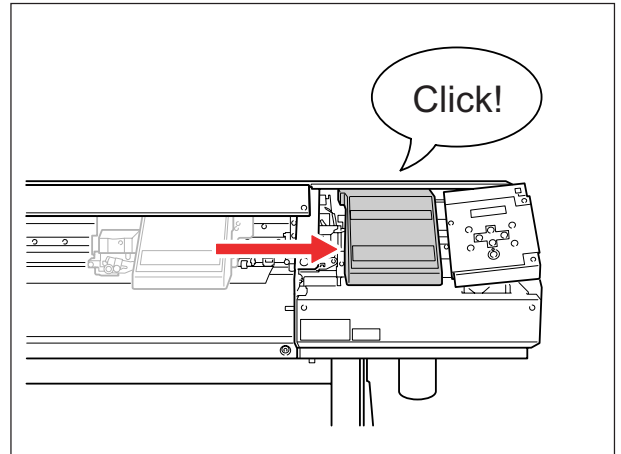

- 6** Turn the Adjustment Screw to adjust the space between the Pen end and Bed to be 2.5mm to 2.6mm.

Move on to the TOOL PRESSURE ADJUSTMENT.

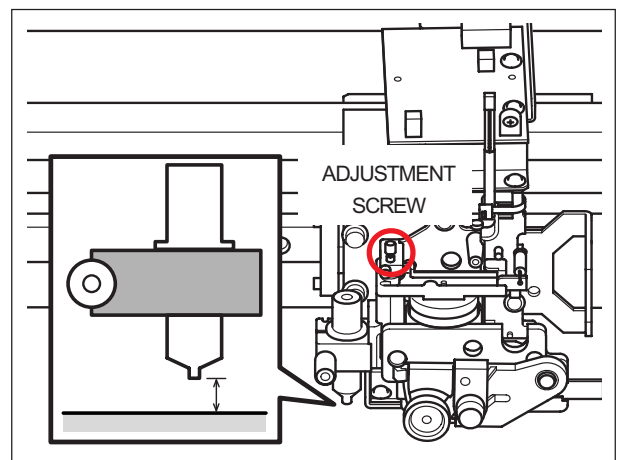

4-13 TOOL PRESSURE ADJUSTMENT (Referential Time : 15min)

This adjustment is to correct the tool pressure during cutting.
Before this adjustment, it is necessary to perform [4-12 TOOL HEIGHT ADJUSTMENT].

- 1 Install the White Dummy Pen (ST-006) to the Tool Carriage.

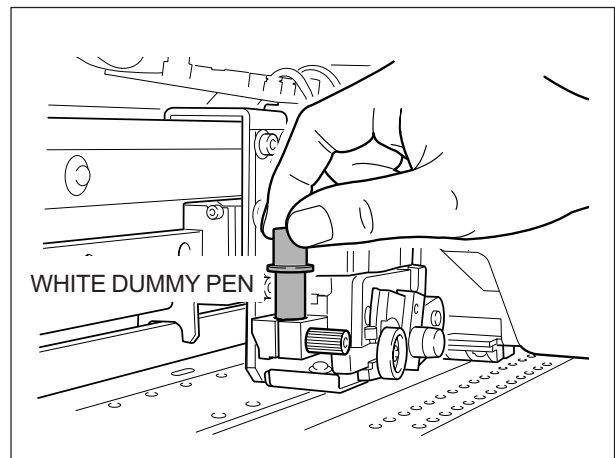

- 2 Move the Pinch Rollers at the positions as shown in the figure, and lower them.

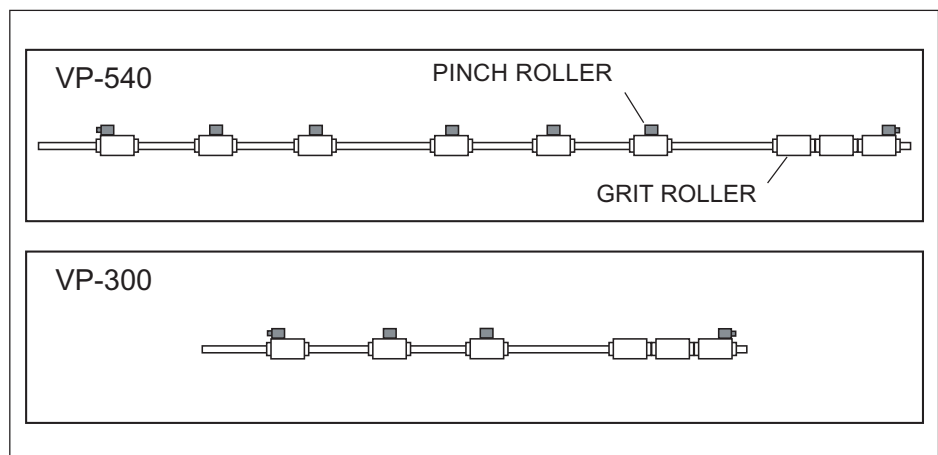

- 3 Remove the Covers in order.

1. I/S Cover
2. Maintenance Cover
3. Left Cover
4. Front Cover
5. Top Cover

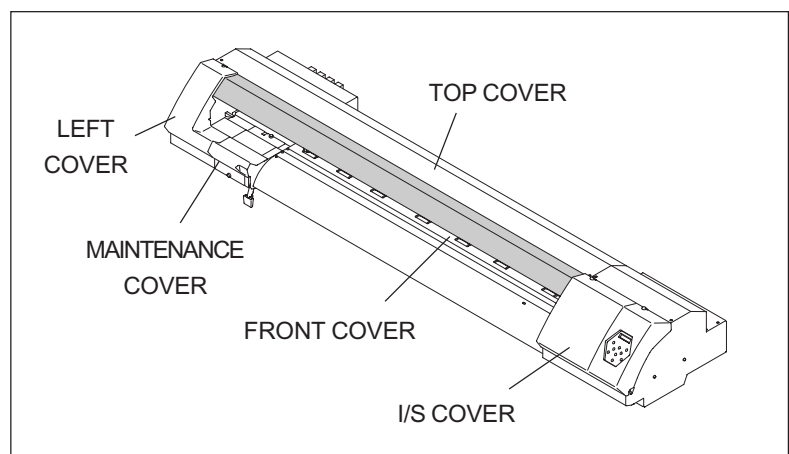

- 4** Move the Head Carriage to the highest position of the bed.

Confirm that Head Carriage is connected to Tool Carriage and lock the connected carriages.



The right end is the highest position of the bed.

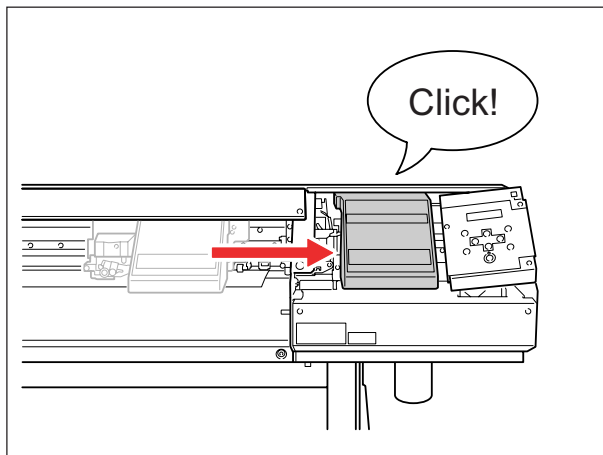

- 5** Turn on the Sub Power SW while pressing [◀], [▼] and [▶] keys to enter the Service Mode.

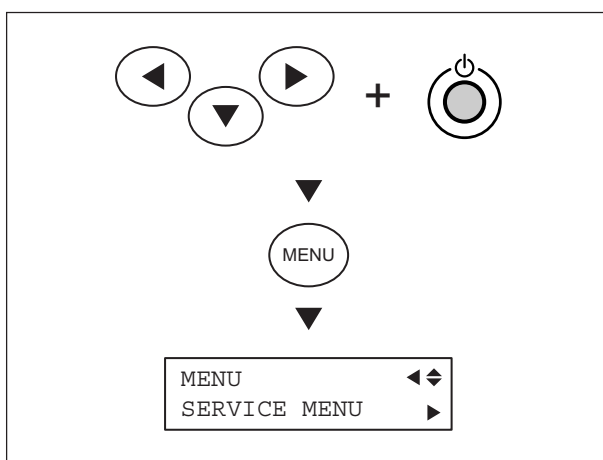

- 6** Select [CUTTING MENU]> [FORCE ADJUST].



Only the Tool Carriage can be moved in [FORCE ADJUST] menu.

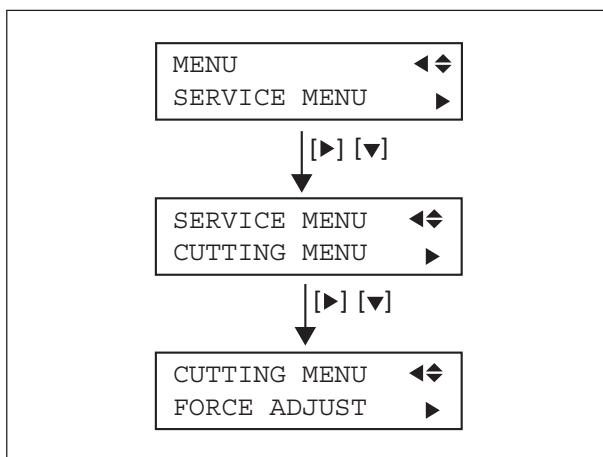

- 7** Select [FORCE ADJUST]> [30gf], and press [PAUSE] key to move the Tool Carriage down.

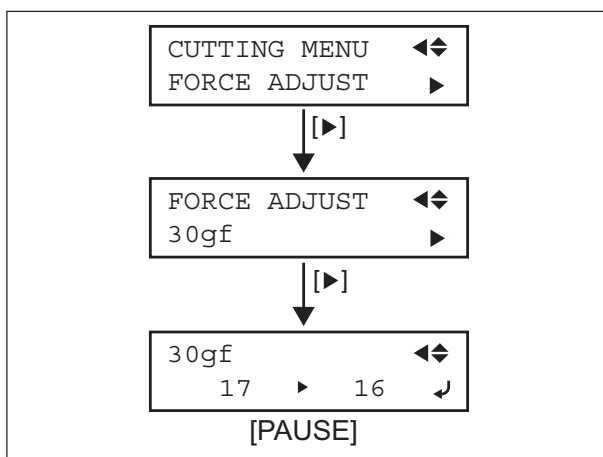

- 8** Lift up the Tool Holder with the Dial Gauge (ST-013) and measure the pressure when the pen tip leaves the bed. Adjust the parameter in [30gf] menu with [▲] and [▼] keys for the pressure to be 25 to 35gf (0.25N to 0.35N). Press [ENTER] key to save the settings.

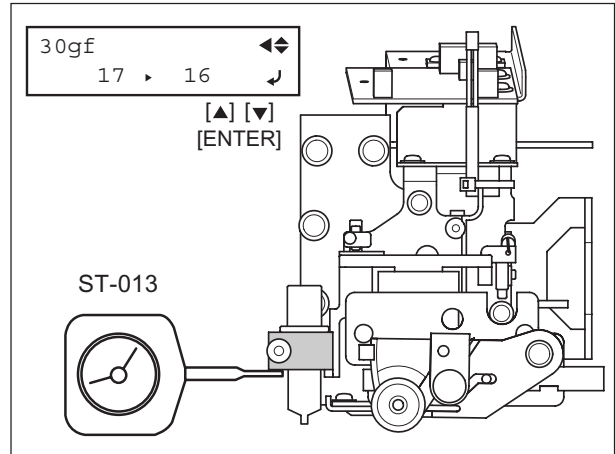

- 9** Select [FORCE ADJUST]> [200gf], and press [PAUSE] key to move the Tool Carriage down.

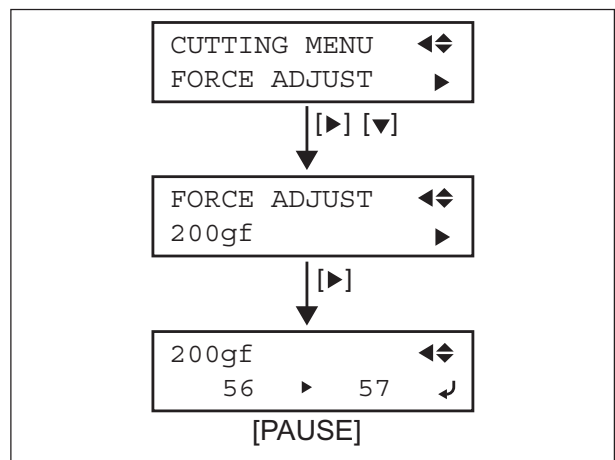

- 10** Lift up the Tool Holder with the Tension Gauge (ST-002) and measure the pressure when the pen tip leaves the bed. Adjust the parameter in [200gf] menu with [▲] and [▼] keys for the pressure to be 195 to 205gf (1.9N to 2.0N). Press [ENTER] key to save the settings.

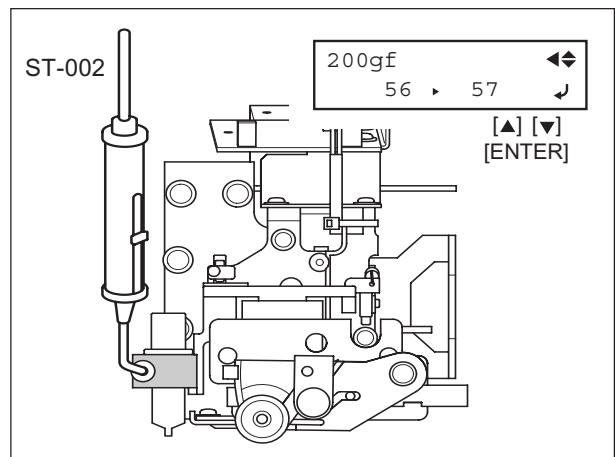

- 11** Select [30gf] menu under [FORCE ADJUST] menu. Confirm that the force is 25 to 35gf (0.25N to 0.35N) when the tip of the pen leaves the bed by lifting the Tool Holder with the Dial Tension Meter (ST-013).

If the value of the force is not proper, repeat the adjustment again.

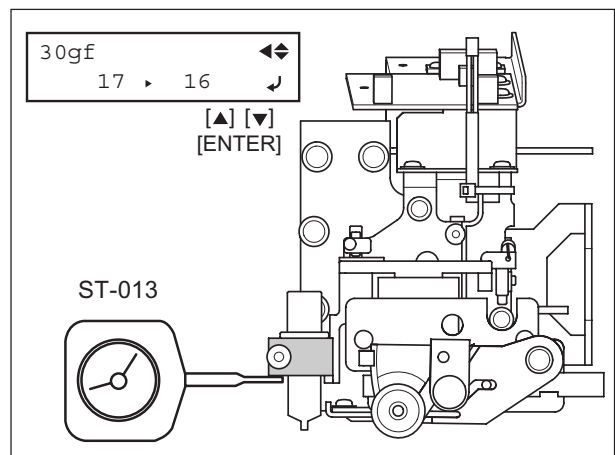

4-14 BELT TENSION ADJUSTMENT (Referential Time : 20min.)

- 1** Connect the Tool Carriage to the Head Carriage and move them to the right in the lock position.

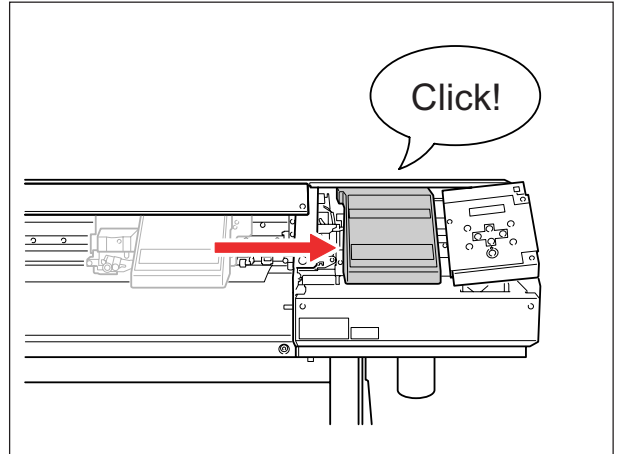

- 2** Remove the Covers in order.

1. I/S Cover
2. Maintenance Cover
3. Left Cover
4. Front Cover
5. Top Cover

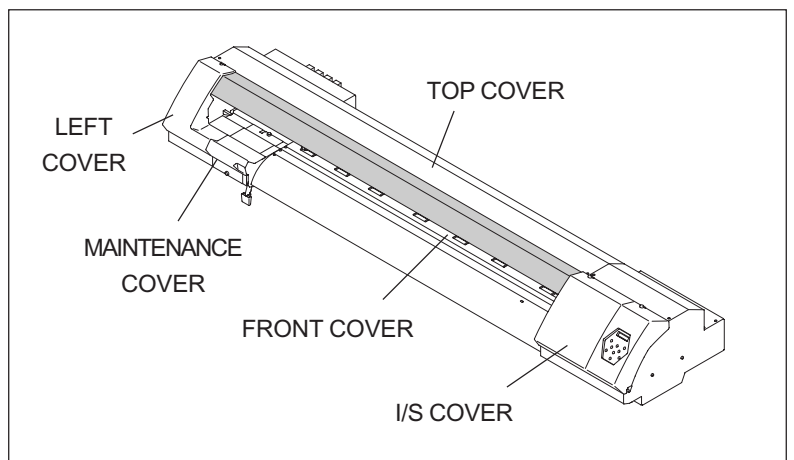

- 3** [VP-540]
 Measure the tension of the belt at the position above the center of the 4th Grit Roller from the left using Tension Gauge (ST-001)(*1).
 Pull up the belt until its inside comes to the top surface of the Cable Guide when you see it from the machine front(*2). The tension is proper if the measured value is 0.82kgf to 0.90kgf.
 If the tension is improper, move on to the next step and adjust the belt tension.

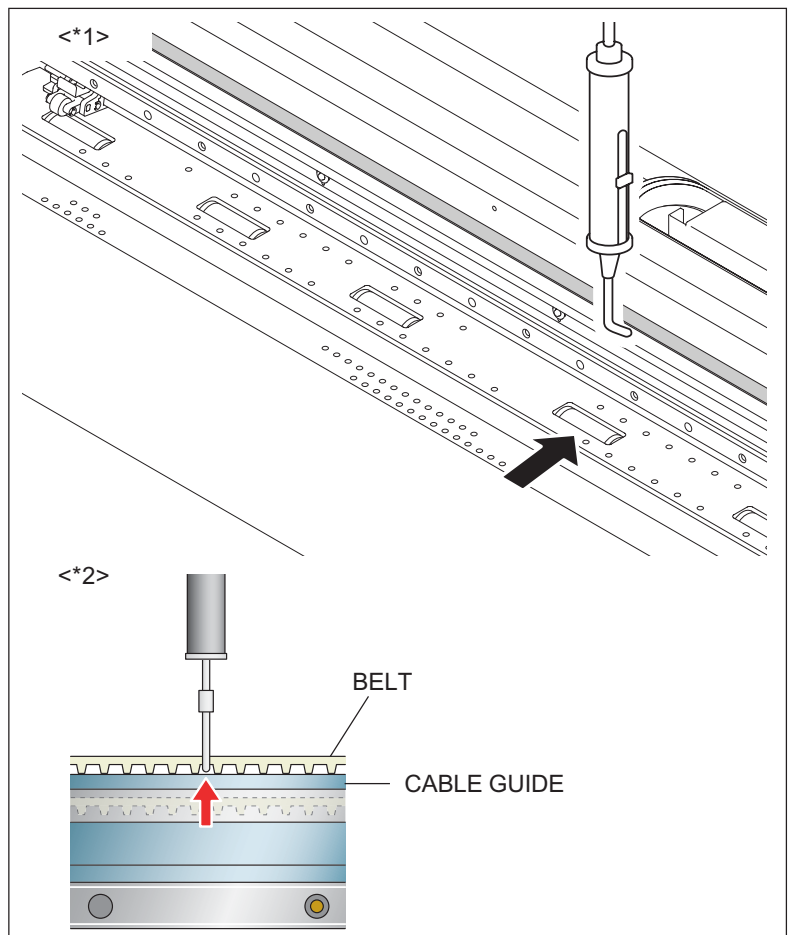

[VP-300]

Measure the tension of the belt at the empty screw hole of the LM Guide between the 2nd and 3rd Grit Rollers from the left using Tension Gauge (ST-001)(*1).

Pull up the belt until its inside comes to the top surface of the Cable Guide when you see it from the machine front(*2). The tension is proper if the measured value is 1.25kgf to 1.40kgf.

If the tension is improper, move on to the next step and adjust the belt tension.

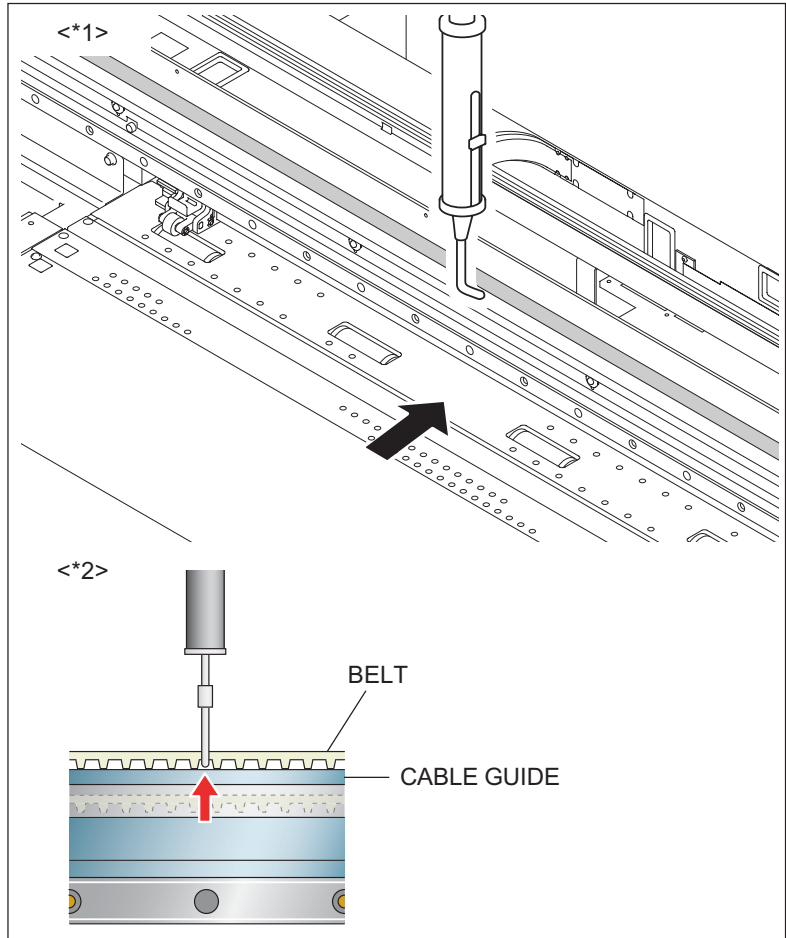

- 4** Loosen the 2 Fixing Screws which is located on the left end of the belt halfway round.



Be careful with the sharp edges around the belt when loosening the screws. It may cause injury.

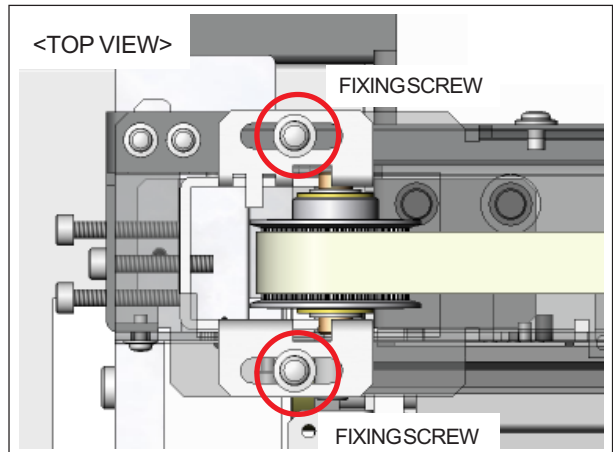

- 5** Insert a wrench through the holes on the Side Frame and loosen the 2 screws to make a gap of 3mm between the tip of the screw and Idle Pulley Holder.
(The belt tension cannot be adjusted higher when the screw contacts with Idle Pulley Holder.)



The gap between the screws and Idle Pulley can be seen from both front side and rear side of the machine.

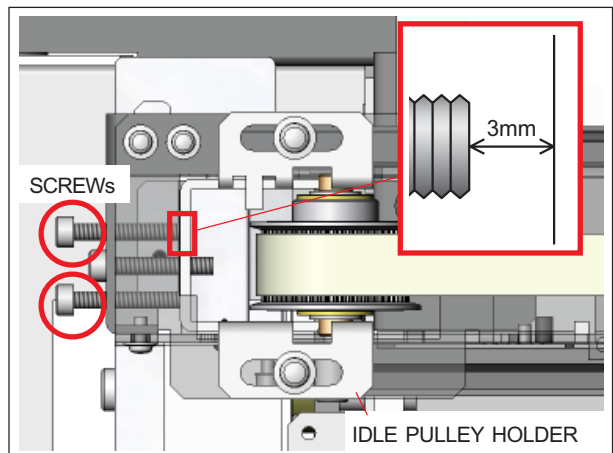

- 6** Turn the Adjustment Screw as shown in the figure to adjust the value of the tension gauge within acceptable range referring to step 3.



Turn the screw CW: Tension is increased
Turn the screw CCW: Tension is decreased

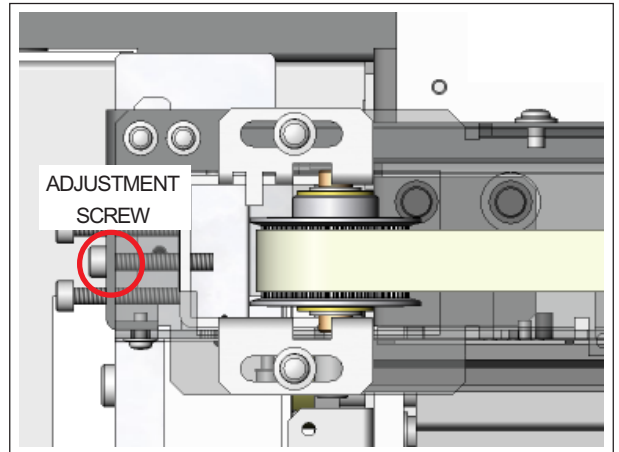

- 7** Tighten the 2 Fixing Screws shown in the figure, and again confirm that the tension is within the proper value.

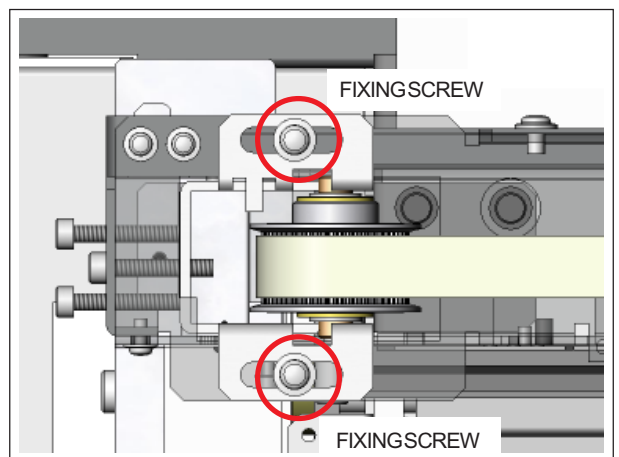

- 8** Tighten the 2 screws shown in the figure to slightly contact with Idle Pulley Holder.

Move on to [4-15 BELT POSITION ADJUSTMENT].



Make sure not to tighten the screws too tight. It may move the fixed Idle Pulley Holder accidentally.

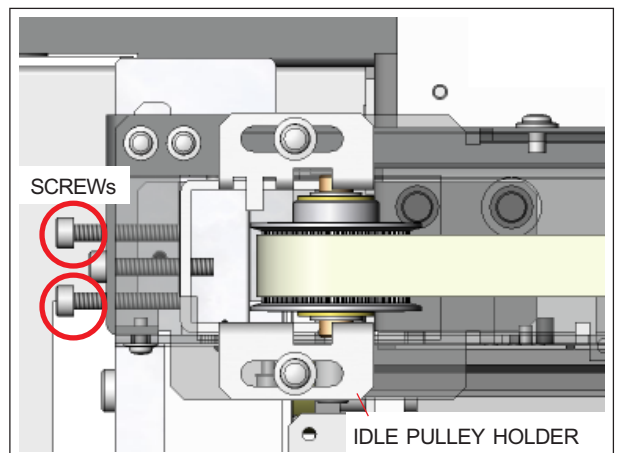

4-15 BELT POSITION ADJUSTMENT (Referential Time : 30min.)

This adjustment is to prevent the belt wear which is caused by the belt contacting with the pulley flanges excessively. The belt position needs to be confirmed after the Belt Tension Adjustment and adjusted if it is necessary.

1 Remove the Covers in order.

1. I/S Cover
2. Right Top Cover
3. Maintenance Cover
4. Left Cover
5. Front Cover
6. Top Cover

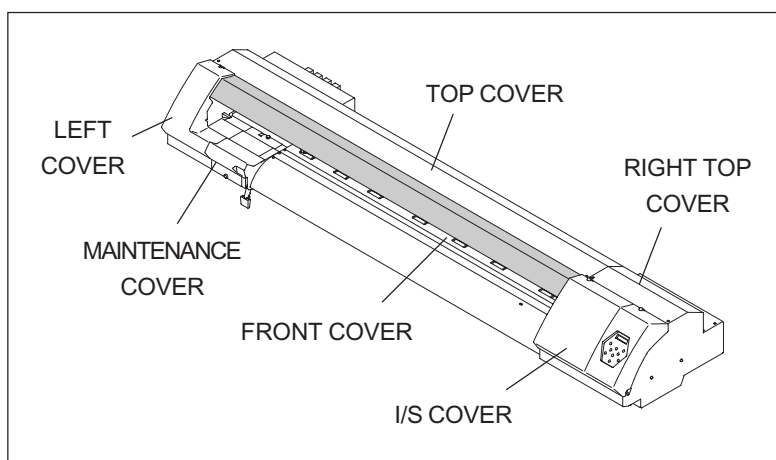

2 Turn on the Sub Power SW while pressing [◀], [▼] and [▶] keys to enter the Service Mode.

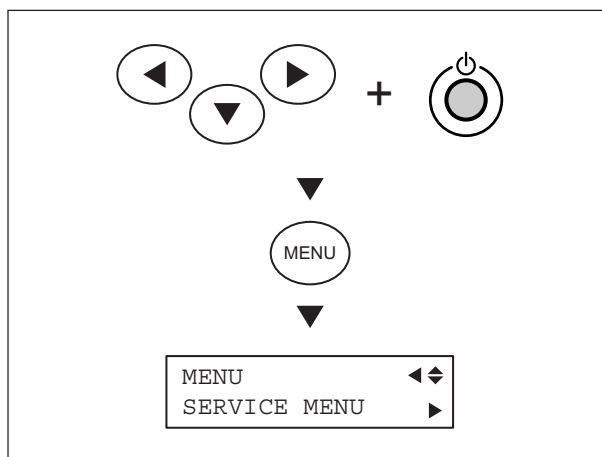

3 [ADJUSTMENT ON THE DRIVE PULLEY SIDE]

Perform the Aging test for the belt.

Select [MOTOR MENU]> [AGING]> [SCAN], and press [ENTER] key.

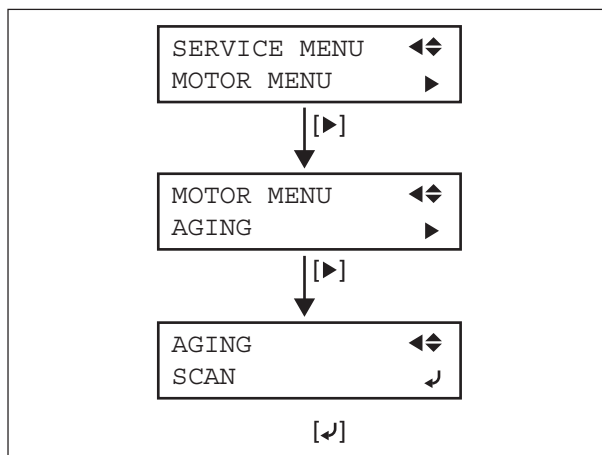

- 4** Confirm the belt position.
The position is proper when the belt is not touching the flanges of the Drive Pulley excessively. When the position is proper, skip this adjustment and go to [ADJUSTMENT ON THE IDLE PULLEY SIDE] described in the later step of this adjustment leaving the belt aging on. When the position is improper, make adjustment as follows.



Belt partly touching the flange is acceptable.

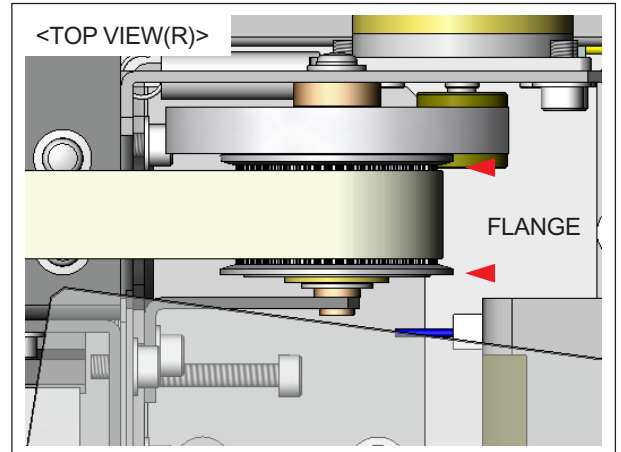

- 5** Press [ENTER] key to cancel Aging.



[↵]

- 6** Remove the Right Side Frame and Chassis Cover.

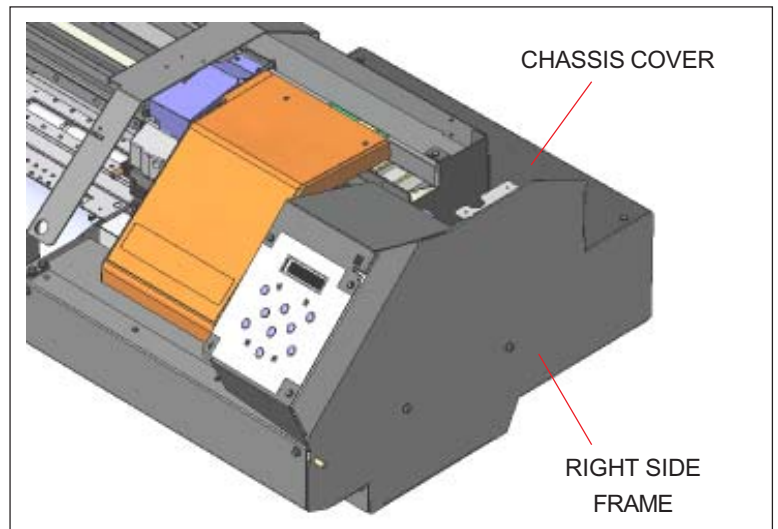

- 7** Loosen the 2 Fixing Screws located on the right end of the belt.



Loosen the screws about a few rounds for the bottom of the screw head not to contact with the Stay.

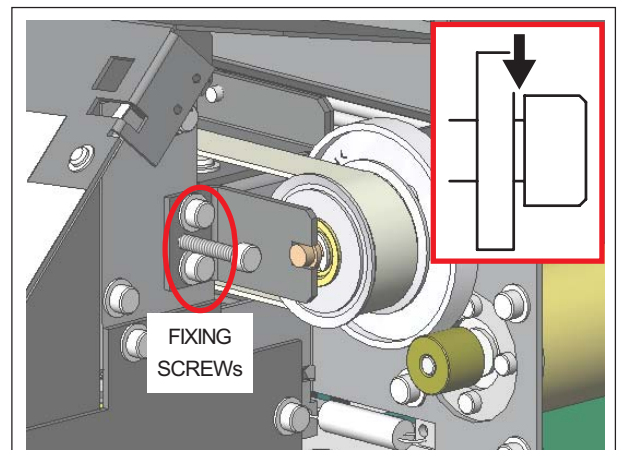

8 Press [ENTER] key to restart Aging.

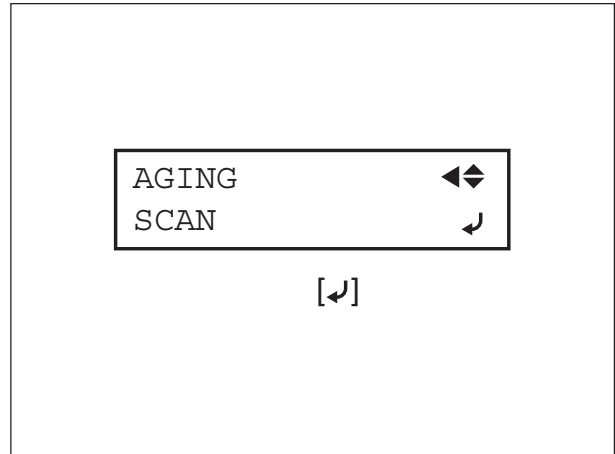

9 Adjust the belt position turning the Adjustment Screw as follows.

Belt leans to the front side of the machine
-Turn the screw carefully in CW (loosening).



The work space is narrow. Be careful and try not to touch the driving pulley and belt.

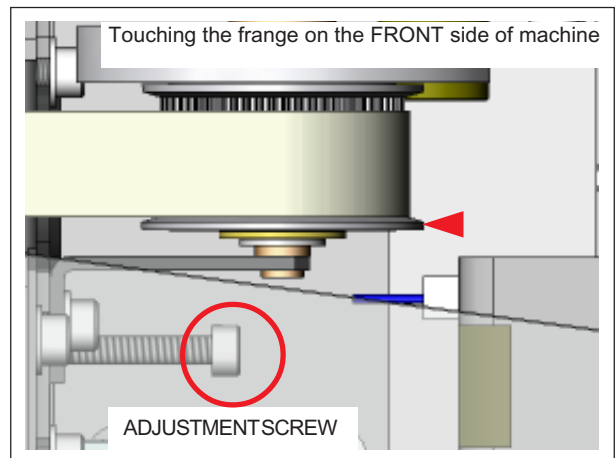

Belt leans to the rear side of the machine
-Turn the screw carefully in CCW (tightening).

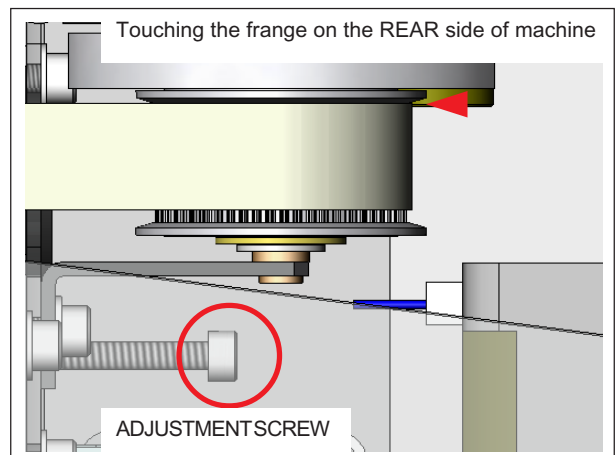

10 Tighten the 2 Fixing Screws for the bottom of the screw head to slightly contact with the Stay.



Make sure not to tighten the screws too tight. It may move the fixed Drive Pulley Holder accidentally.

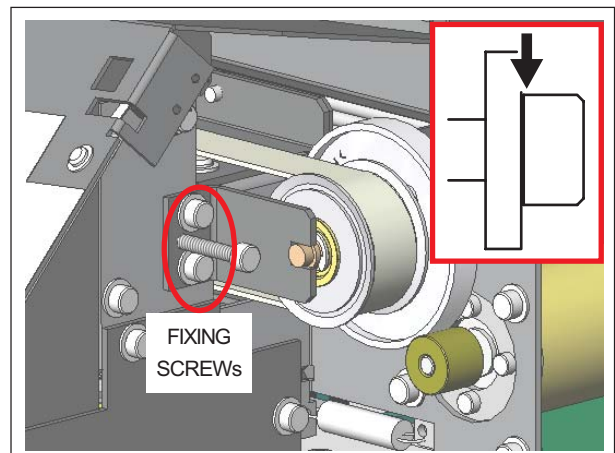

- 11** Confirm that the belt is not touching the pulley flanges excessively.

When the belt is in improper position, adjust it again. When it is proper, leave the belt aging on, and go to the following [ADJUSTMENT ON THE IDLE PULLEY SIDE].

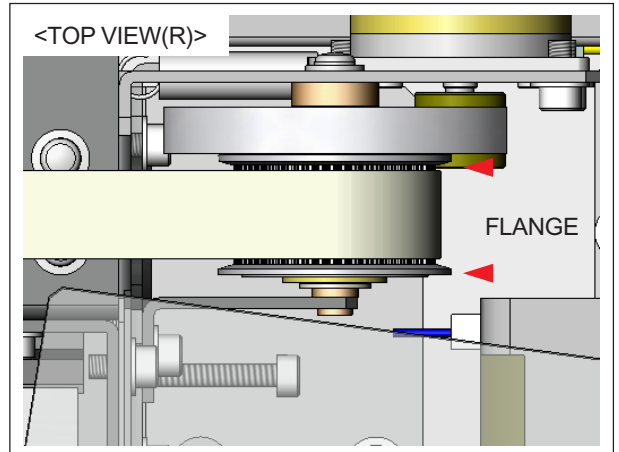

- 12** [ADJUSTMENT ON THE IDLE PULLEY SIDE]

Confirm the position of the belt.

The position is proper when the belt is not touching the flanges excessively. When the position is proper, close this BELT POSITION ADJUSTMENT. When it is improper, make adjustment as follows.



Belt partly touching the flange is acceptable.

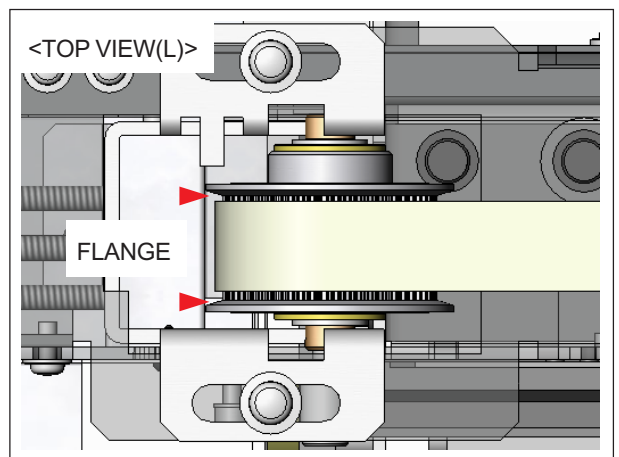

- 13** Press [ENTER] key to cancel Aging.

SCAN ⬅️ ➡️
NOW AGING ↵

[↵]

- 14** Loosen the 2 Fixing Screws located at the left end of the belt eighth to quarter round.



When the screw is loosen more than necessary, it gives difficulty in adjusting the belt. Also, you need to be careful with the sharp edges around it when turning the screws. It may cause injury.

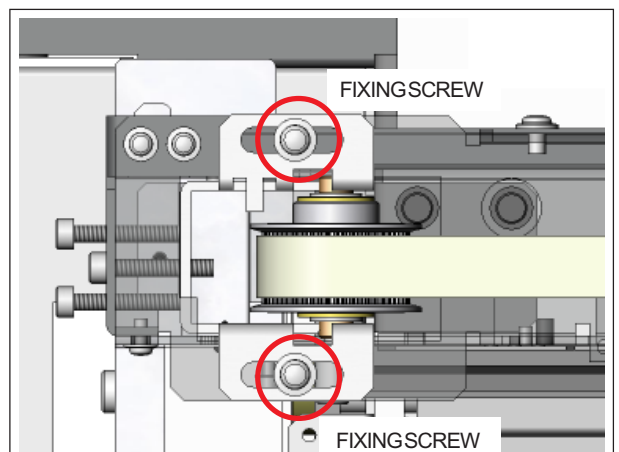

- 15** Insert a wrench through the holes on the Side Frame and loosen the 2 screws to make a gap of 3mm between the tip of the screw and Idle Pulley Holder.



The gap between the screws and Idle Pulley Holder can be seen from both front side and rear side of the machine.

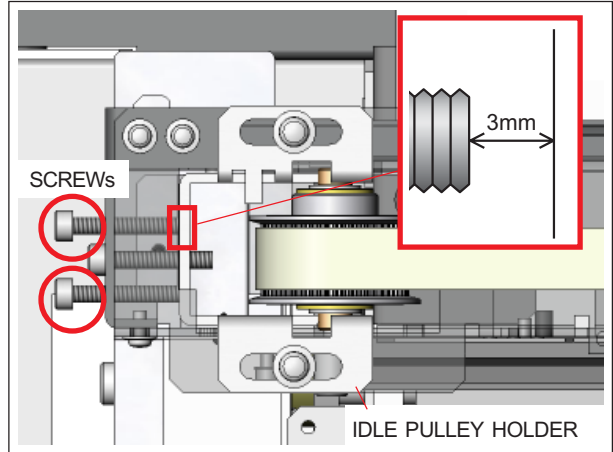

- 16** Press [ENTER] key to restart Aging.

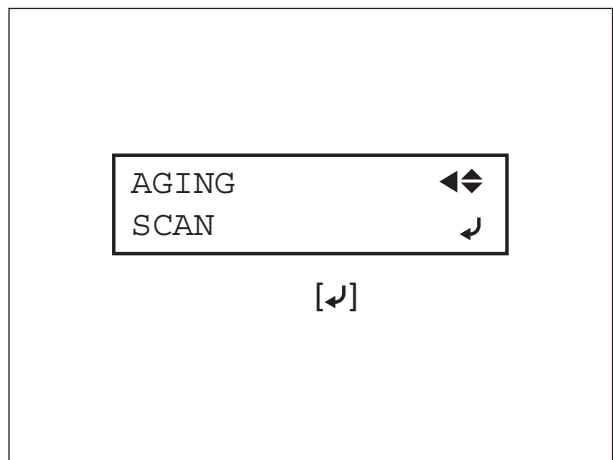

- 17** Insert a wrench through the holes on the Side Frame and adjust the belt position turning the screw 1 and 2 as follows.

Belt leans to the front side of the machine

-Turn the screw 1 carefully in CW to press it to the Idle Pulley Holder.

* Make sure to have a gap of 3mm between the screw 2 and Idle Pulley Holder when turning the screw 1.

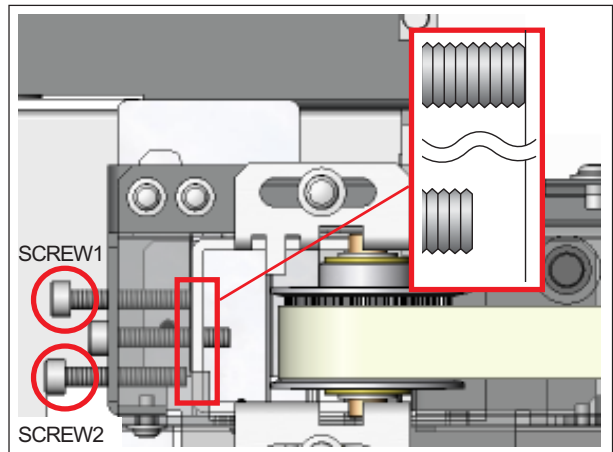

Belt leans to the rear side of the machine

-Turn the screw 2 carefully in CW to press it to the Idle Pulley Holder.

* Make sure to have a gap of 3mm between the screw 1 and Idle Pulley Holder when turning the screw 2.

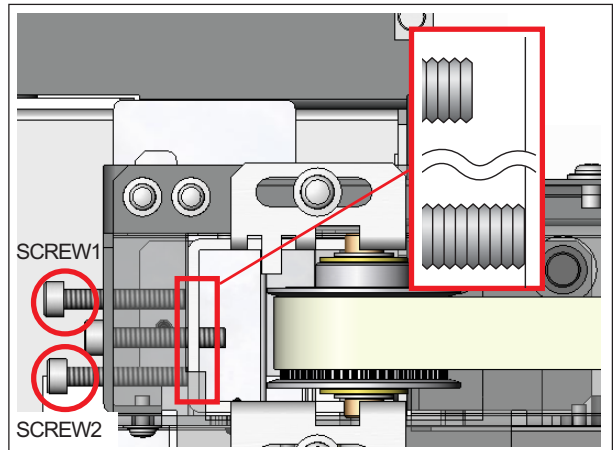

- 18** Tighten one of the screws that has no contact with the Idle Pulley Holder to slightly touch the Idle Pulley Holder.



Make sure not to tighten the screws too tight. It may move the Idle Pulley Holder accidentally.

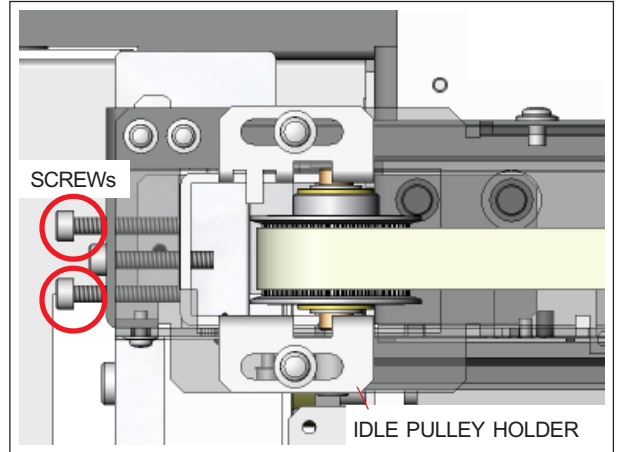

- 19** Tighten the 2 fixing screws as shown in the figure.



Be careful with the moving Carriages during the work, and also with the sharp edges of the mechanical parts around it.

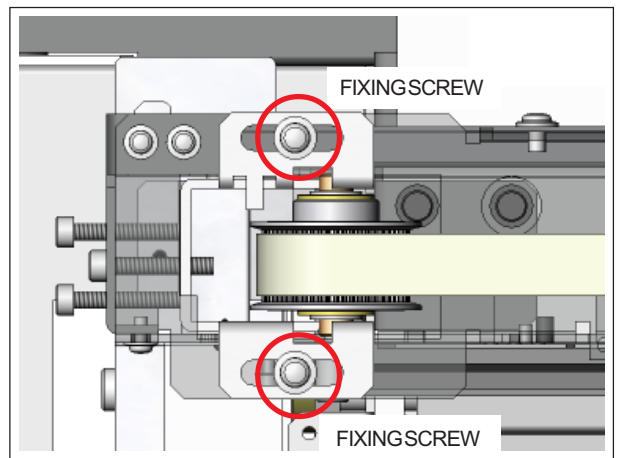

- 20** Confirm that the belt is not touching the Pulley Flanges excessively.

When the belt is in improper position, adjust it again. When it is proper, press [ENTER] key to cancel Aging.

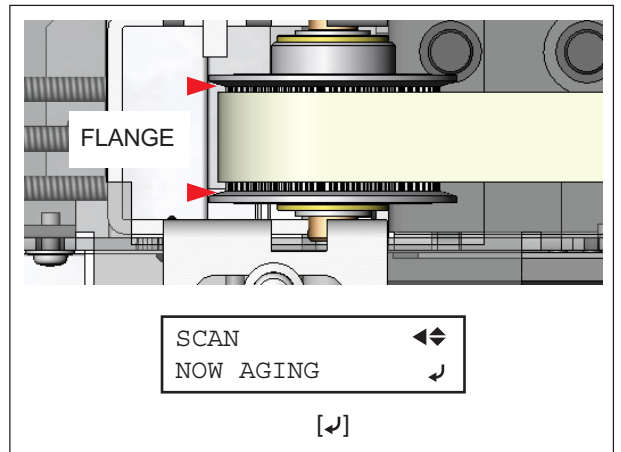

- 21** Fix the Right Side Frame by sliding it from behind to hook the tab as shown in the figure.

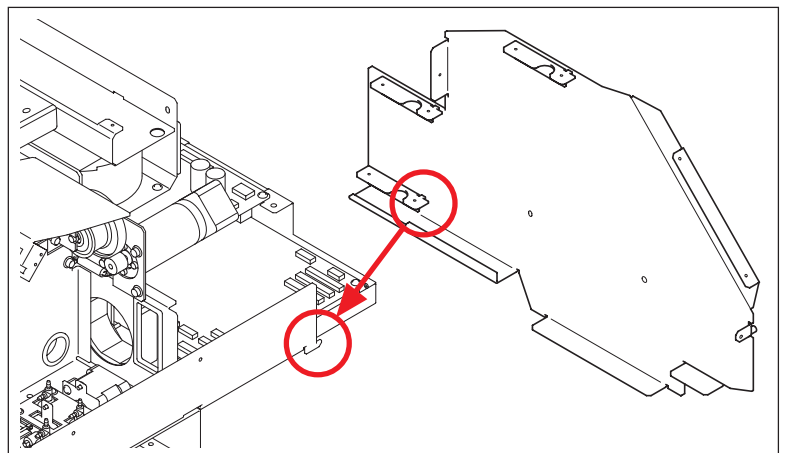

4-16 TAKE-UP UNIT OPERATION CHECK (Referential Time : 2min.)

This is to check whether Take-up Unit operates properly.

- 1 Confirm that the cable of Take-up unit is connected to the connector and turn on the Main Power SW.

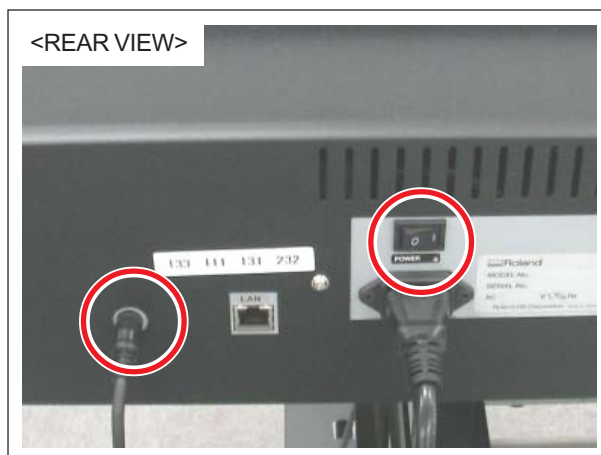

- 2 Turn on the Sub Power SW while pressing [◀], [▼] and [▶] keys to enter the Service Mode.

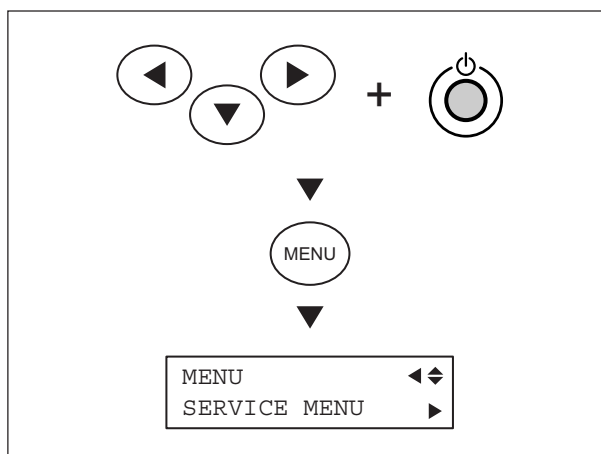

- 3 Select [SUB MENU]> [TU CHECK]> [TU].

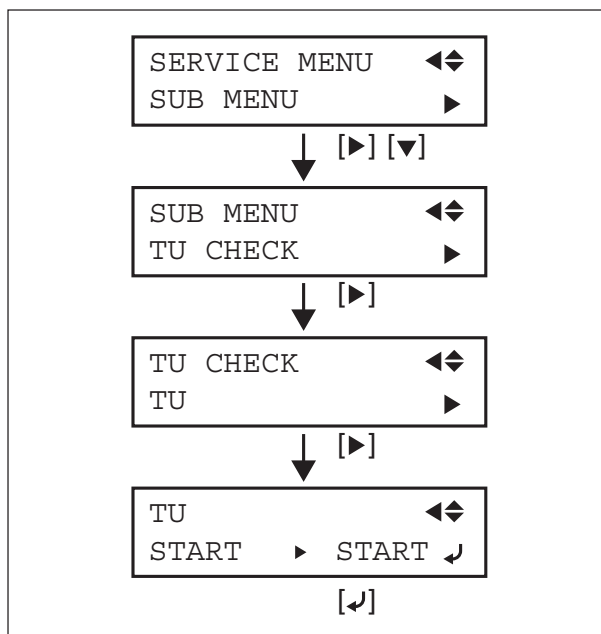

- 4 Confirm that [START] is selected, and press [ENTER] key to turn on the Take-up Unit.



[START] or [STOP] can be selected with [▲] and [▼] keys.
The current setting is displayed on the left and the new setting is displayed on the right.

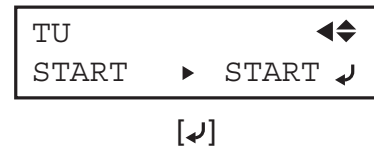

- 5 Set the AUTO switch of the Take-up Unit to either FORWARD or BACKWARD.

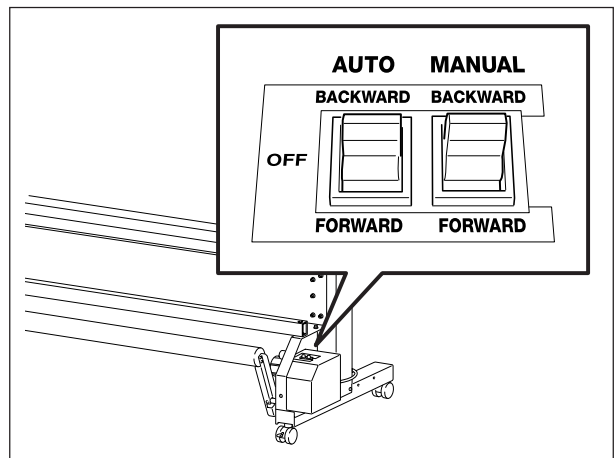

- 6 Move the Dancer Roller up and down by hand, and confirm that the drive part rotates.



The operation status of Take-up Unit can be confirmed also on the LCD. [*] is displayed on the right side of upper LCD while driving, and not displayed while not driving.

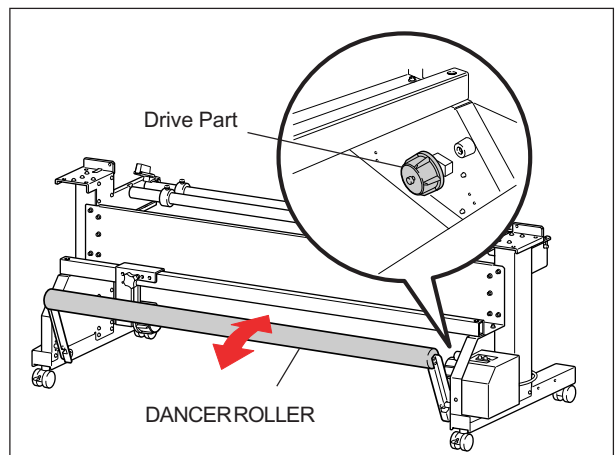

- 7 Select [STOP] with [▲] and [▼] keys, and press [ENTER] key.



- 8** Move the Dancer Roller up and down by hand, and confirm that the drive part does not rotate.





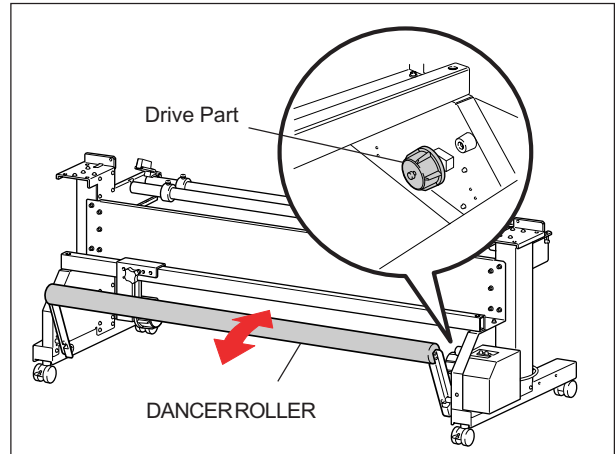

The setting of [STOP] is canceled when exiting the menu. The initial setting is [START] every time entering [TU] menu.

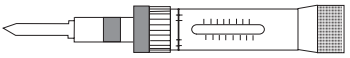

5 Supplemental Information

5-1 Special Tools

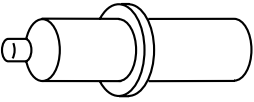
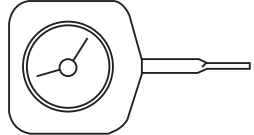
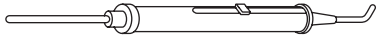
Table shows a list of special tools recommended by Roland DG Corp.

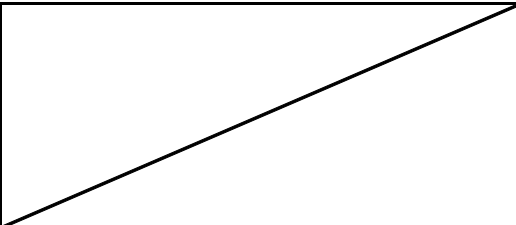
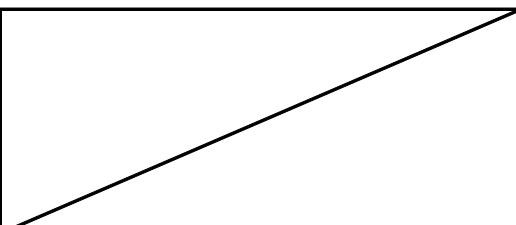
Tool No.	ST-056	
Tool Name	TORQUE DRIVER N6	
Purpose	HEAD ALIGNMENT	
Tool No.	ST-002	
Tool Name	TENSION GAUGE 300g (3N)	
Purpose	TOOL PRESSURE ADJUSTMENT	
Tool No.	ST-006	
Tool Name	WHITE DUMMY PEN	
Purpose	TOOL HEIGHT ADJUSTMENT TOOL PRESSURE ADJUSTMENT	
Tool No.	ST-013	
Tool Name	DIAL TENSION METER DT-100 (100g/1N)	
Purpose	TOOL PRESSURE ADJUSTMENT	
Tool No.	ST-001	
Tool Name	TENSION GAUGE 2000GF/2000CN	
Purpose	BELT TENSION ADJUSTMENT	
Tool No.	ST-037	
Tool Name	CLEAN STICK TX712A	
Purpose	HEAD CLEANING	
Tool No.	21755107	
Tool Name	CLEANING LIQUID (SL) 500ML	
Purpose	HEAD CLEANING (SOL)	
Tool No.	22085118	
Tool Name	KIT, CLEANING (SL)	
Purpose	HEAD CLEANING (SOL) *Cleaning Liquid + Cleaning Sticks 10 pcs.	

5-2 SENSOR MAP

REAR PAPER SENSOR

It detects the rear edge of the media and also whether the media is loaded or not.

LIMIT SENSOR

It detects the limit position of the head carriage in the scan direction.

IS COVER SENSOR

It detects whether the IS Cover is opened or closed.

HEAD LOCK SENSOR

It detects whether the HEAD CARRIAGE is at the lock position or not.

THERMOSTAT (HEATER)

If the Heater exceeds the limit temperature, it stops the power supply.

THERMOSTAT (DRYER)

If the Dryer exceeds the limit temperature, it stops the power supply.

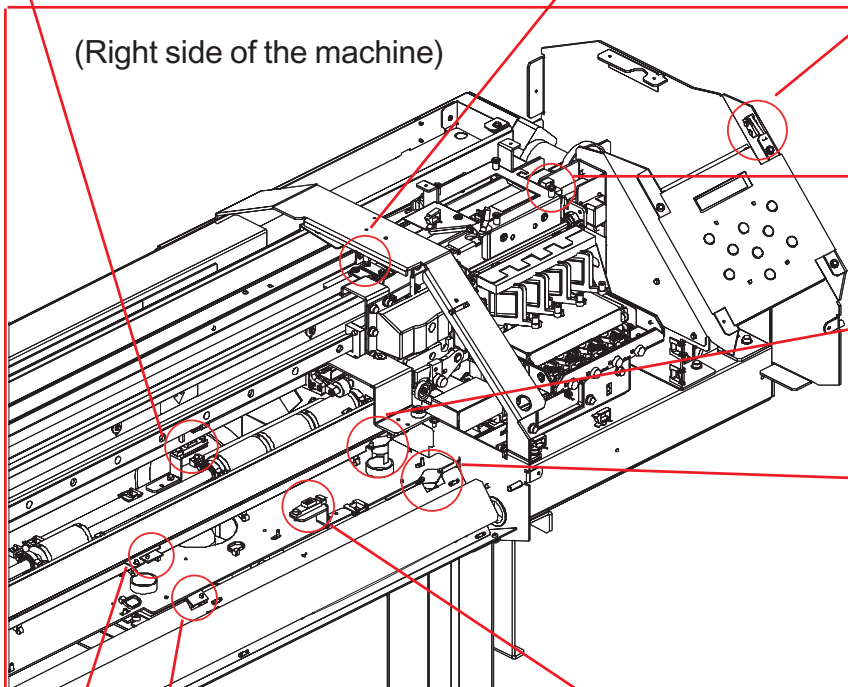

(Right side of the machine)

THERMISTOR(DRYER)

It takes the temperature of the Dryer.

THERMISTOR(HEATER)

It takes the temperature of the Heater.

FRONT PAPER SENSOR

It detects the front edge of the media.

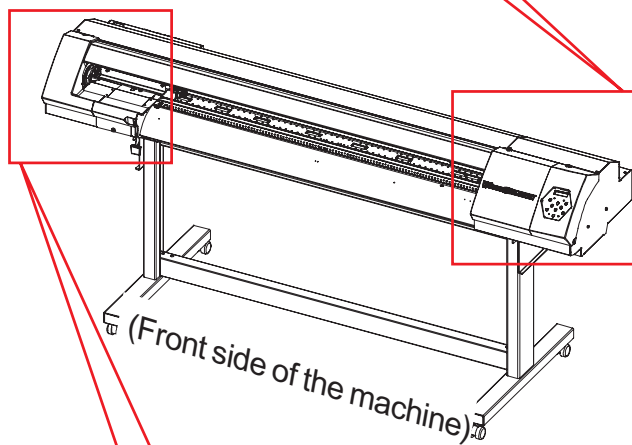

(Front side of the machine)

(Left side of the machine)

MAINTENANCE COVER SENSOR

It detects whether the Maintenance Cover is set or not.

FEED ENCODER MODULE

It detects the rotation position of the Grit Roller.

SHEET LOAD SENSOR

It detects whether the Sheet Loading Lever is UP or DOWN.

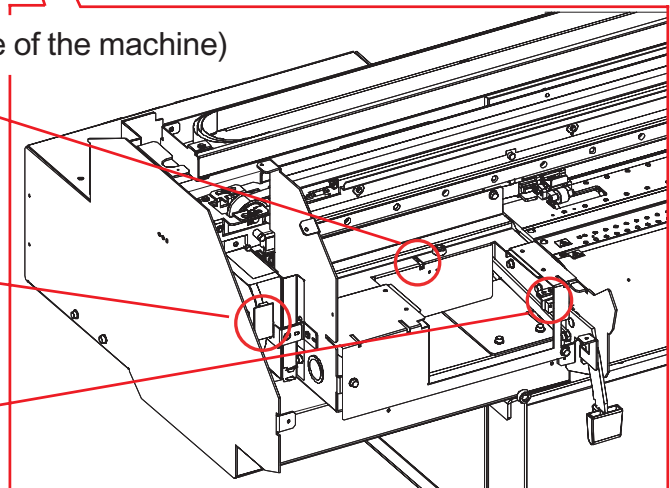

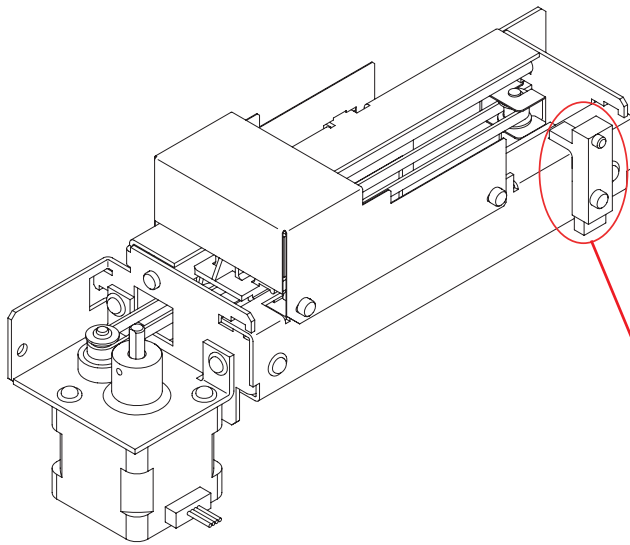

WIPER SENSOR

It detects the limit position of the Wiper movement.

ENCODER MODULE

It detects the coordinates in the carriage moving direction, and also generates the print signal.

**HEAD UP/DOWN SENSOR
(for VP-540 ONLY)**

It detects the position of the Head Height Lever.

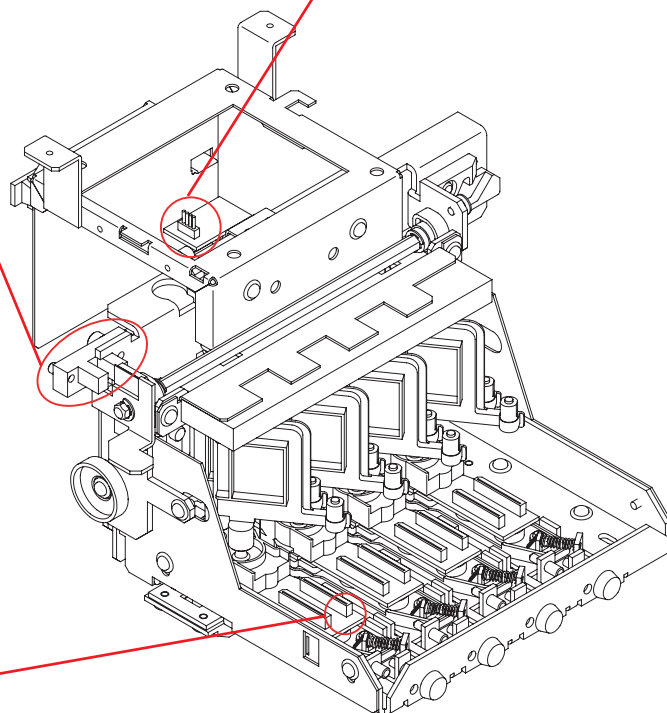

THERMISTOR

It takes the temperature around the Head.

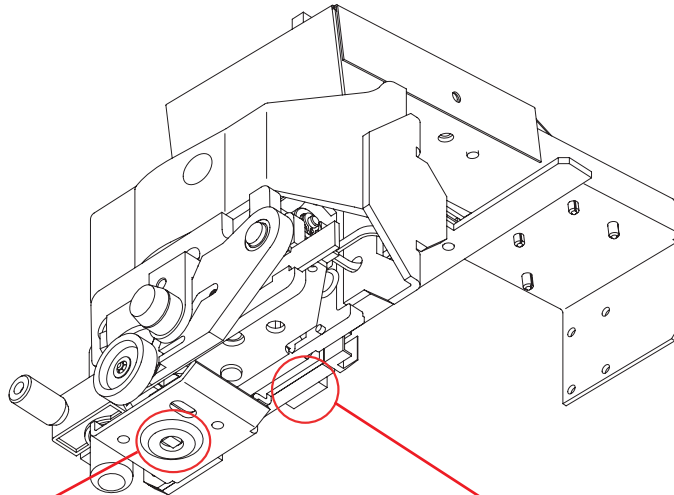

CROP MARK SENSOR

It detects the Crop Mark.

PINCH ROLLER SENSOR

It detects the positions of Pinch Roller.

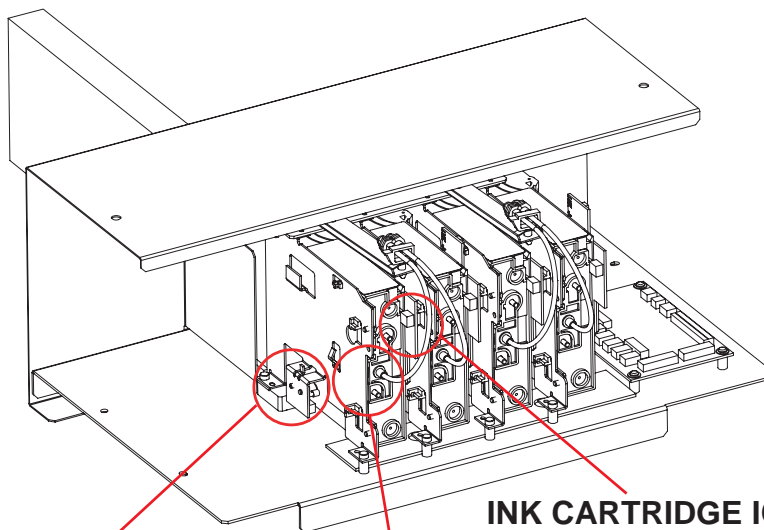

INK EMPTY SENSOR

It detects whether the Ink Cartridge is empty or not.

INK CARTRIDGE IC SENSOR

It communicates with the IC chip of the Ink Cartridge.

INK CARTRIDGE SENSOR

It detects whether the Ink Cartridge is installed or not.

6 Troubleshooting

6-1 DEFECT OF PRINT QUALITY (BANDING/SCRATCHY PRINTING/BLURRED PRINTING)

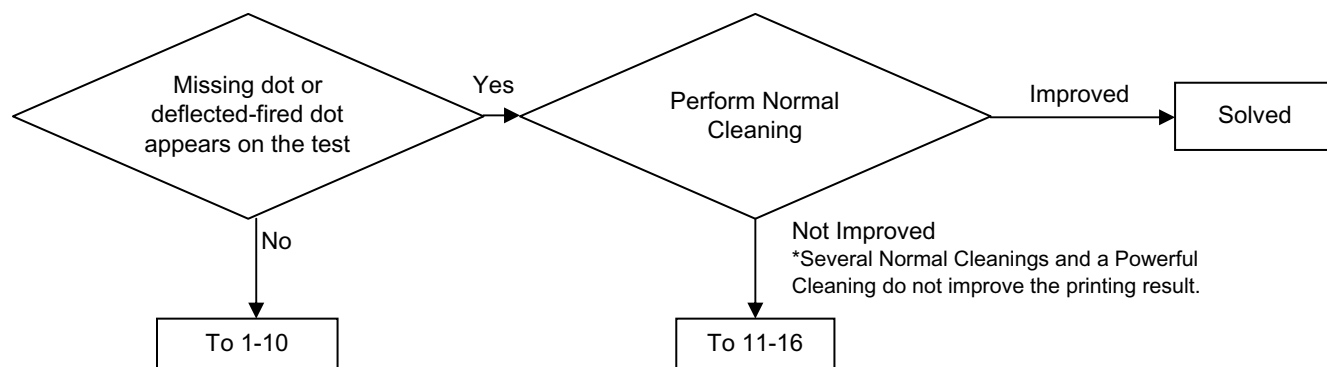

NO	CHECKING POINT	ACTION	REFERENCE	OUTLINE
1	Machine is not installed in an appropriate location	Install in a location that is level and stable.		Never install the machine in a location where it is tilted or where it may wobble or librate.
2	Media is not set up correctly	Load and set up the media correctly at the correct position.	User's Manual	Feed is not smooth when media is tilted or tensioned unevenly on the left and right. Reload and set up the media correctly.
3	Temperature of the print heater is inappropriate	Set appropriate temperature	User's Manual	When the temperature of the print heater is too high and the ink dries too fast, it may result in banding because the dots stay small after landing on media.
4	Bi-directional adjustment is not correct	Correct setting for Bidirectional Printing	User's Manual	
5	Feed Calibration is not correct	Apply Calibration	User's Manual	If the calibration is not correct, white fine line caused by gaps or dark line caused by overlapping appears.
6	Scanning distance of the Head Carriage	Set the [FULL WIDTH S] to [FULL]	User's Manual	Set [FULL WIDTH S] to [FULL] to uniform the heating time on each pass. This may improve printing quality.
7	[PERIODIC CL.] setting	Set [PERIODIC CL.] to [NONE] or [Page]	User's Manual	When this is set to [1 min] to [990 min], self cleaning is performed while a printing is paused. And it may cause uneven printing at the part before and after cleaning.
8	Wrong profile for the media	Use a suitable Profile		
9	Head Rank is not correct	Set Head Rank	[3-1 HEAD REPLACEMENT]	Head Rank setting affects the amount of the fired Ink. If it is not set properly, the ink dots are not fired in appropriate sizes.
10	Head is out of adjustment	Head Alignment	[4-4 HEAD ALIGNMENT]	Check whether each [BIAS], [VERTICAL], [HORIZONTAL] and [BI-DIR.DEFAULT] settings are correct.
11	Foreign substances stuck on the head	Manual cleaning.	User's Manual	Nozzle condition becomes poor due to the foreign substances stuck on the surface of the Head.
12	Wiper wears out	Wiper replacement	[3-2 WIPER REPLACEMENT]	Wiping does not work effectively and foreign substances left on the head surfaces cannot be removed completely.
13	Defect of Cap Top	Cap Top replacement	[3-3 CAP TOP REPLACEMENT]	Cleaning does not work effectively and the nozzle condition cannot be improved. Also, if the head is not capped correctly, the head dries and it may cause the head nozzle clogging.
14	Head nozzle is clogged	Clean the head surface using the cleaning stick. (Manual Cleaning)		Generally, we do not recommend to wipe the surface of Head with a cleaning stick. However, it's worth trying before replacing the Head. Soak the cleaning stick in cleaning liquid fully, and then tap and scrub the surface of Head with it.
15	Broken Head	Head replacement	[3-1 HEAD REPLACEMENT]	
16	Broken Pump	Pump replacement		Ink suction during cleanings does not work and the nozzle condition cannot be improved.

6-2 PARTICULAR COLOR IS NOT PRINTED AT ALL

NO	CHECKING POINT	ACTION	REFERENCE	OUTLINE
1	Ink Cartridge is almost empty	Check remaining Ink / Replace the Ink Cartridge	User's Manual	When the machine keeps printing with ink cartridge almost empty, the negative pressure delivered in the ink tube causes the improper ink supplying and the head cannot fire the ink correctly.
2	Error of Ink Empty detection	Replace the ink cartridge/ sensor		If the cartridge tab does not stick out when it is empty, it cannot detect it empty and printing is continued without firing ink. Also, if the sensor is not working, Ink Empty cannot be detected even if the cartridge tab sticks out.
3	Bad contact/Broken cable	Refix / Replace the cable		If there is a bad communication between the head and the Main Board, the signal for driving head is not sent properly and results in not printing properly. If the Flexible cable is fixed slanted, it may cause the bad electrical contact or short-circuit. And, the cable which has been conneted and disconnected several times may have a damaged terminal.
4	Defect of Cap Top	Cap Top Replacement	[3-3 CAP TOP REPLACEMENT]	If the Head is not capped correctly, the Head dries and it may cause the Head nozzle clogging.
5	Air bubbles in Ink line	Powerful Cleaning/ Remove air bubbles by an syringe		When air bubbles come inside the Ink line, the head may not fire the Ink temporarily. Air bubbles tend to go into the Ink line if Ink Cartridge is installed and uninstalled so many times. The air bubbles inside the lines can be removed by performing the powerful cleaning or using a syringe.
		Eliminate the looseness of the tube joint		If the tube has air due to the looseness of the tube joint, fix the joint and remove the air.
6	Broken Ink Tube	Ink Tube Replacement	[3-8 INK TUBE REPLACEMENT]	
7	Broken Fuse on the Main Board	Replace the Fuse on the Main Board		The F1 Fuses are for M and Y, and the F2 Fuses are for K and C. If the M and Y Heads do not fire any Ink at all, the F1 Fuse may be defective. If the K and C Heads do not, the F2 Fuse may be defective.
8	Broken Main Board	Main Board Replacement	[3-9 BOARDS REPLACEMENT]	There might be a problem with the other devices on the Main Board if the Fuses are not defective.
9	Broken Head	Head Replacement	[3-1 HEAD REPLACEMENT]	

6-3 SHIFTING IN PRINTING/COLOR SHIFTING

NO	CHECKING POINT	ACTION	REFERENCE	OUTLINE
1	The media is set tilted	Set the media correctly	User's Manual	If media is not set straight, it comes loose on the Platen and it wrinkles, and results in shifting. Set the media straight referring to the User's Manual.
2	Encoder Scale is dirty/broken	Clean or replace Encoder Scale	[3-12 ENCODER SCALE REPLACEMENT]	When Encoder Scale is not read correctly, printing position may shift.
3	Encoder Module is dirty/broken	Clean or replace Encoder Module		When Encoder Scale is not read correctly, printing position may shift.
4	Head is out of adjustment	Head Alignment	[4-4 HEAD ALIGNMENT]	If the Heads are not aligned or Horizontal adjustment is not performed properly, the color shifting occurs.
5	Bad contact of Flexible cable	Refix / Replace the Flexible cable		If the Flexible cable is not fixed correctly, the Head moves incorrectly and results in the shifting in printing.

6-4 INK DROPS ON THE MEDIA

NO	CHECKING POINT	ACTION	REFERENCE	OUTLINE
1	Foreign substances	Manual Cleaning	User's Manual	When foreign substances such as fiber dust are stuck on the surface of the Head, Ink sometimes leaks from it. Wipe the surface of Head with a cleaning stick.
2	Media strikes Head	Use the media clamps/ Replace with a suitable media		If media tends to curl or become bumpy due to the Ink absorption, the Head sometimes strikes the media while printing and it causes the Ink dropping problem.
3	Static electricity of the media	Perform [PERIODIC CL]	User's Manual	If media produces static electricity easily, the ink tends to remain on the head surface while printing and results in ink dropping. When this is set to [1 min] to [990 min], automatic cleaning is performed while printing and it may prevent the ink dropping.
4	Wiper wears out	Wiper Replacement	User's Manual	Cleaning does not work effectively with worn wiper. Therefore, foreign substances stuck on the head surface cannot be removed completely and the ink flows through it and results in ink dropping.
5	Broken ink tube	Ink Tube Replacement	[3-8 INK TUBE REPLACEMENT]	When the ink tube is broken, it is not possible to keep the ink line air tight and results in ink dropping.
6	Broken Head	Head Replacement	[3-1 HEAD REPLACEMENT]	When a head is broken mechanically such as a crack, it is not possible to keep the ink line air tight and results in the ink dropping.

6-5 VERTICAL BANDING

NO	CHECKING POINT	ACTION	REFERENCE	OUTLINE
1	Encoder Scale is dirty	Clean / Replace Encoder Scale	[3-12 ENCODER SCALE REPLACEMENT]	When there is scratch or dirt on the Encoder Scale, the printing image could be affected and the vertical bandings appear at the position where there is scratch or dirt.
2	LM Guide is dirty	Clean LM Guide		When the sliding resistance with the moving Head Carriage increases partly due to some dirt on the LM Guide, it may affect the printing at the position where there is dirt and the vertical banding may appear.
3	There is dirt in the teeth of the gear	Clean the gear		When there are foreign substances on the teeth of the gear, the movement of the Head Carriage changes at the position where there is dirt. And it results in the periodical vertical banding.

6-6 MISSING DOT OR DEFLECTED-FIRED DOT APPEARS WHEN PERFORMING PRINTING WITH LONG DELAY

NO	CHECKING POINT	ACTION	REFERENCE	OUTLINE
1	Check the main power switch	Do not switch off the main power	User's Manual	When the main power is off, the maintenance flushing is not performed and it may cause the Head nozzle clogging. Make sure to power on/off with only the sub power switch for daily use.

6-7 Print & Cut Misalignment

Ideal Conditions



The above illustration shows the ideal print and cut conditions where the red stars signify the printed image and the black lines signify the cut path. Since the actions to be taken are different depending on the conditions of shifting, check how cutting is shifted first and take appropriate actions. Most of the actions can be done by users.

Symptom 1 : Cut is Shifted in the Same Direction for the Same Amount



Possible Causes

Print & Cut adjustment is not correctly done.

Actions

1. Perform [ADJUST BI-DIR] in the User menu.
2. Perform [PRINT-CUT ADJ.] in the User menu.

Symptom 2 : Cut is OK at Right Side but is Getting Shifted as It Goes to the Left Side



Possible Causes

1. Expansion/Contraction of the Encoder Scale
2. There is some setting value other than 0 set in [CUTTING MENU]>[CALIBRATION]>[SCAN SETTING].
3. Expansion/Contraction of the media

Actions

1. Enable [CUTTING MENU]>[AUTO ENV.MATCH] in the User menu.
2. Set 0 in [CUTTING MENU]>[CALIBRATION]>[SCAN SETTING] in the User menu.
3. Perform [ADJUST BI-DIR] in the User menu.
4. Perform [PRINT-CUT ADJ.] in the User menu.
5. Use the crop marks.

Symptom 3 : Cut is OK at Lead Edge but is Getting Shifted as It Goes to the End of Print



Possible Causes

1. There is some setting value other than 0 set in [CUTTING MENU]>[CALIBRATION]>[FEED SETTING].
2. Expansion/Contraction of the media
3. Strong back tension of the heavy roll media causes the media to be fed less than it should be when printing.

Actions

1. Set 0 in [CUTTING MENU]>[CALIBRATION]>[FEED SETTING] in the User menu.
2. Prefeed the media to make it unrolled before starting a printing to decrease the back tension.
3. Use the crop marks.
4. Divide the file into 2 or more and output them as separate jobs in order to make the feeding distance of each job shorter.

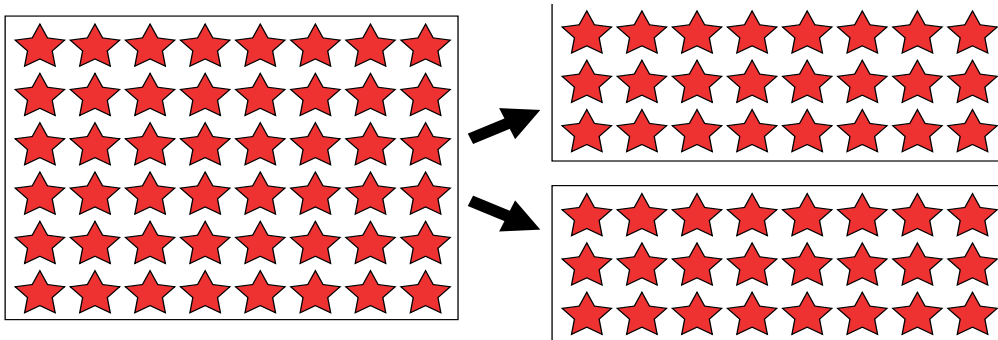

Symptom 4 : Symptom1, 2 and 3 are Mixed or Details are Not Clear



Actions

1. Enable [CUTTING MENU]>[AUTO ENV.MATCH] in the User menu.
2. Set 0 in [CUTTING MENU]>[CALIBRATION]>[SCAN SETTING] and [FEED SETTING] in the User menu.
3. Perform [ADJUST BI-DIR] in the User menu.
4. Perform [PRINT-CUT ADJ.] in the User menu.
5. Prefeed the media to make it unrolled before starting a printing to decrease the back tension.
6. Decrease [SPEED] and [UP-SPEED] in [CUT CONFIG].
7. Divide the file into 2 or more and output them as separate jobs in order to make the feeding distance of each job shorter.
8. Use the crop marks.
9. Adjust the belt tension.

Symptom 5 : Cut is Shifted When Using Crop Marks

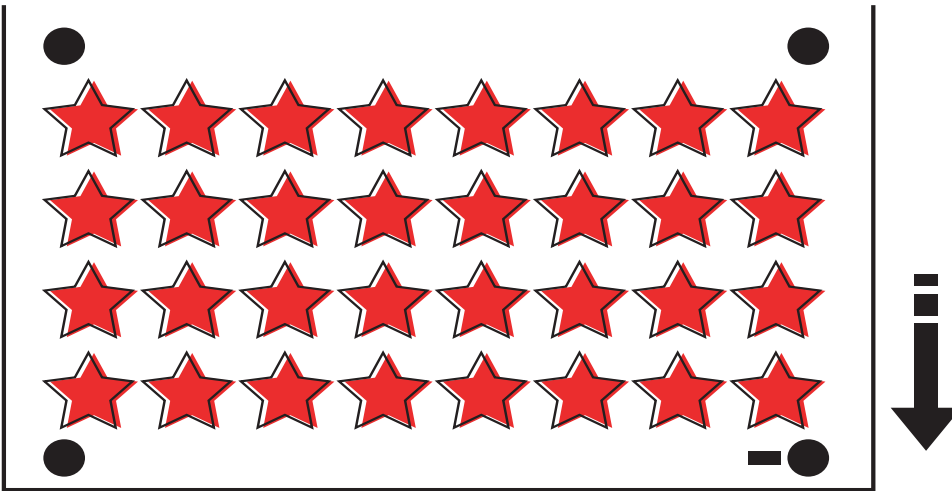

Possible Causes

1. Crop-cut adjustment is not correctly done.
2. Crop mark sensor adjustment is not correctly done.

Actions

1. Perform [ADJUST BI-DIR] in the User menu.
2. Perform [CROP-CUT ADJ.] in the User menu.
3. Perform the crop mark sensor adjustment by executing [CROPMARK SENS]>[OUTLEVEL CHECK] in the Service menu.

6-8 POOR CUTTING QUALITY (STITCH CUT, DISTORTED CUT, MISMATCHED START AND END POINTS)

NO	CHECKING POINT	ACTION	REFERENCE	OUTLINE
1	Blade Holder is fixed loose	Fix the Blade Holder tightly.		
2	Blade-offset setting is not correct	Set the blade-offset correctly.		
3	Cutting force is not correct	Tool pressure adjustment	[4-13 TOOL PRESSURE ADJUSTMENT]	
4	Middle Pinch Rollers are not used	Use the Middle Pinch Rollers.		When using only left and right pinch rollers, middle part of the media won't follow both edges when the media is fed and this may affect the cutting quality.
5	Blade tip is worn out	Replace the Blade		
6	Blade Holder tip is caught by the media	Don't use the Blade Holder tip		Depending on the surface condition or the types of media, Blade Holder tip gets caught by the vinyl and it results in stitch cut.
7	Bearing inside Blade Holder doesn't rotate smoothly	Replace the Blade Holder		
8	Scratch in Cutter Protection	Replace the Cutter Protection		
9	Tool height is not correct	Adjust the tool height	[4-12 TOOL HEIGHT ADJUSTMENT]	
10	Tool doesn't move up/down smoothly	Replace the Tool Carriage	[3-4 TOOL CARRIAGE REPLACEMENT]	
11	Tool Carriage is loose	Replace the Tool Carriage	[3-4 TOOL CARRIAGE REPLACEMENT]	
12	Holder part of Tool Carriage is loose	Replace the Tool Carriage	[3-4 TOOL CARRIAGE REPLACEMENT]	
13	Backlash of Motor Gear	Adjust Backlash		When there is a backlash at the Scan motor or Feed motor, Tool Carriage and Grit Roller will be driven unstable and results in symptoms such as mismatched start and end points.
14	Belt Tension is not correct	Belt Tension Adjustment		
15	Solenoid IC on Servo Board is damaged	Replace IC23 on the Servo Board		When the driver IC that drives solenoid is damaged, rarely abnormal tool pressure is given. In this case, the blade hits the bed and jumps when it goes down and it results in stitch cutting.

6-9 MEDIA SKEW

NO	CHECKING POINT	ACTION	REFERENCE	OUTLINE
1	Media Flanges are not fixed by the stoppers	Fix the Flanges with the stopper	User's Manual	Media Flanges are fixed with the stoppers. If they are not fixed, Media roll shifts left and right while it is fed and it may result in media skew.
2	Flanges are not set correctly to the Media	Set the Media Flanges again	User's Manual	When the flanges are not fully put in the media tube, Media is fed tilted and it may result in Media shifting.
3	Media is not set straight to the machine	Setup Media again	User's Manual	The most effective measure against Media shifting is to set Media straight to the machine. Especially on lengthy printing, small tilt of Media setup results in big Media shifting while printing.
4	Grit Roller is dirty	Clean the Grit Roller		When dust such as pieces of vinyl is stuck to the Grit Roller, ability to hold Media decreases and it results in Media shifting. Use a brush to clean the Grit Roller.
5	Pinch Roller is worn out	Replace the Pinch Roller	[3-14 PINCH ROLLER REPLACEMENT]	When pinch rollers wear out, ability to hold media decreases and it results in media shifting. Referential time for replacing Pinch Roller is 24 months.
6	Grit Roller is loose	Fix the Grit Roller		

6-10 MOTOR ERROR

NO	CHECKING POINT	ACTION	REFERENCE	OUTLINE
1	Media Jamming	Remove cause of Media Jam		
2	Back tension of media is too high	Use appropriate media		When using hard-to-unroll or too heavy media, Motor Error occurs due to the too much load for feeding the media.
3	There is a dirt in teeth of Drive Gear	Clean Drive Gear		When the Drive Gear has some dirt on its teeth and cannot rotate, Motor Error occurs.
4	Broken/life of the Motor	Motor replacement	[3-5 CARRIAGE MOTOR REPLACEMENT]	When the Motor is broken or reaches its life, the Motor cannot follow the order from the CPU and it results in a Motor Error.
5	Broken Servo Board	Servo Board replacement		When the Motor Driver is broken, the power supply voltage for the motor is not supplied and the motor cannot move. It results in a Motor Error.
6	Power Supply for Motor is broken	Replace the switching power supply	[3-9 BOARDS REPLACEMENT]	When the Power Supply voltage for the Motor is not supplied, the Motor cannot move and it results in a Motor Error.

ERROR DESCRIPTION

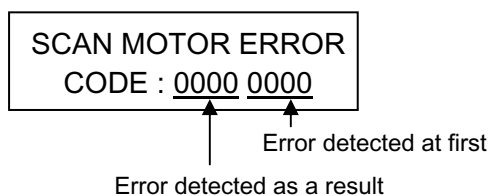

No.	MEANING	CAUSE
0001	Feed Motor Deviation Error (The order from the CPU does not match the feedback of the Feed Motor.)	< External factors > 1. Media Jamming 2. Carriage is moved by hands. 3. Carriage runs into a thing/hand. 4. Media is stuck because it is caught by the paper pipe. 5. Media is pulled forcibly. 6. Loaded Media is too heavy. < Machine factors > 1. The grease lubrication of the motor gear is not enough. 2. Motor is broken/Life. 3. Servo Board is broken. 4. Tool Carriage fixation to the belt is loose.
0004	Feed Motor Overcurrent Error 1 (Big load is put on the motor movement instantaneously.)	
0008	Feed Motor Overcurrent Error 2 (A little load is put on the motor movement for a long time.)	
0005	0001 and 0004 occurred at the same time.	
0009	0001 and 0008 occurred at the same time.	
0010	Scan Motor Deviation Error (The order from the CPU does not match the feedback of the Scan Motor.)	
0040	Scan Motor Overcurrent Error 1 (Big load is put on the motor movement instantaneously.)	
0080	Scan Motor Overcurrent Error 2 (A little load is put on the motor movement for a long time.)	
0050	0010 and 0040 occurred at the same time.	
0090	0010 and 0080 occurred at the same time.	

6-11 HEATER / DRYER TEMPERATURE DOES NOT GO UP

NO	CHECKING POINT	ACTION	REFERENCE	OUTLINE
1	The media is not loaded	Set up the media.	User's Manual	
2	Inappropriate temperature is set on the machine	Check the temperature setting	User's Manual	When the setting of print heater/dryer is off, the Heater does not operate.
3	Media width is too small	Use a wider media		When media is narrow, the air-cooling effect by the vacuum fan increases and it takes time for the heater temperature to go up.
4	Environmental temperature is low	Raise the environmental temperature	User's Manual	In cold environment, it may take a long time or the Heater may fail to reach the preset temperature. Suggest using the machine under the environment from 20 to 32 °C.
5	The voltage of power supply is unstable	Check the voltage		If the voltage is unstable, the heater cannot function fully.
6	Bad contact or cut line on the cable between the Heater Unit and Main Board	Re-fix / Replace the cable		If the cable between the Heater unit and Main Board is broken, the Heater temperature does not rise. Check the connection of the each cable or replace it if it is broken.
7	Fuse on the power board is broken	Replace the fuse on the power board		The temperature of the Heater does not rise if the Fuse FS300 or FS301 on the power board is burned out. FS300 is for the print heater and FS301 for the dryer.
8	Power Board is broken	Replace the power board		The Heater does not work correctly because the signal to the Heater is not transferred correctly.

6-12 PROBLEM IN NETWORK (RIP DOES NOT RECOGNIZE THE PRINTER)

NO	CHECKING POINT	ACTION	REFERENCE	OUTLINE
1	Turn off the main power and restart the printer			It can be solved by restarting the printer with the main power. Try it several times.
2	Refix the cable			It can be solved by refixing the network cable. Try it several times.
3	Network problem	Connect them directly with a crossover cable.		The problem may be in the network when they are connected through LAN. It can be identified whether the problem is on the printer or the network, by connecting the PC and the printer directly with a crossover cable.
4	Main board is damaged	Replace the main board.		Main board may be damaged if the problem is not solved by the measures above.

6-13 ERROR MESSAGE

NO	CHECKING	ACTION	REFERENCE	OUTLINE
1	service call	Restart the machine		Restart the machine and see if the same error occurs again.
		Refer to [6-14 SERVICE CALL]	[6-14 SERVICE CALL]	
2	Internal Error	Restart the machine		Restart the machine and see if the same error occurs again.
		Upgrade the firmware to the latest version		Check the revision record of the firmware version and upgrade it if the error has been solved in the firmware.

6-14 SERVICE CALL

CODE	CONTENTS	CAUSE	ACTION
0002	Disorder of communication with Sub CPU This occurs when the Sub CPU is not detected after turning on the machine	Servo Board does not work correctly. Sub CPU does not work correctly. There is a bad connection between Main Board and Servo Board.	Check cable connection between Main Board and Servo Board. Check the other cable connections of Servo Board. Servo Board replacement Main Board replacement Flexible cable replacement
0004	Sub CPU SRAM error	SRAM is broken.	Servo Board replacement
0005	An error occurs while downloading a program for sub CPU.	Servo Board does not work correctly. Sub CPU does not work correctly. There is a bad connection between Main Board and Servo Board. A noise on a signal.	Check cable connection between Main Board and Servo Board. Check the other cable connections of Servo Board. Servo Board replacement Main Board replacement Flexible cable replacement
0006	An error occurs when trying to connect with sub CPU.	A noise on a signal while sending a command. Sub CPU was reset to default. Tried to communicate when Sub CPU was reset to default.	Check cable connection between Main Board and Servo Board. Check the other cable connections of Servo Board. Servo Board replacement Main Board replacement Flexible cable replacement
0007	An error occurs while sending a command.	Servo Board does not work correctly. Sub CPU does not work correctly. There is a bad connection between Main Board and Servo Board. A noise on a signal while sending a command. Sub CPU was reset while sending a command.	Check cable connection between Main Board and Servo Board. Check the other cable connections of Servo Board. Servo Board replacement Main Board replacement Flexible cable replacement
0008	There is a problem with synchronizing serial communication to Sub CPU.	Servo Board does not work correctly. Sub CPU does not work correctly. There is a bad connection between Main Board and Servo Board. A noise on a signal.	Check cable connection between Main Board and Servo Board. Check the other cable connections of Servo Board. Servo Board replacement Main Board replacement Flexible cable replacement
0010	Network I/F Initialize has not been completed.	Network I/F does not work correctly. Firmware for Network I/F is not installed.	Check the firmware is installed into Network I/F. Main Board replacement
0101	Limit Position Initialize in the Service Mode has not been done.	Limit Position Initialize has not been done. Limit Position Initialize is ended before it is completed.	Complete Limit Position Initialize correctly.
0102	Even though the machine carries out the regular movement, the output of Head Lock Sensor does not reach the expected value.	Head Lock Sensor does not work correctly or is broken.	Head Lock Sensor replacement Check the mechanical backlash or loose with the scan axis related parts.
0103	Even though the machine carries out the regular movement, the output of Limit Sensor does not reach the expected value.	Limit Sensor does not work correctly or is broken.	Limit Sensor replacement Check the mechanical backlash or loose with the scan axis related parts.
0105	Tool Carriage Connection Error	Fault of Tool Carriage Connection Loose of Connection Part Fault of the Limit Position Initialize value Limit Sensor does not work correctly or is broken.	Check the mechanical Backlash or loose with the Tool Carriage part. Connection Part Replacement Limit Position Initialize
0106	Machine fails to disconnect the Tool Carriage from the Head Carriage.	Fault of Tool Carriage Connection Loose of Connection Part Fault of the Limit Position Initialize value Limit Sensor does not work correctly or is broken.	Check the mechanical Backlash or loose with the Tool Carriage part. Connection Part Replacement Limit Position Initialize
0107	Linear Encoder Setup has not been done.	Linear Encoder Setup has not been done. Linear Encoder Setup is ended before it is completed.	Carry out Linear Encoder Setup in service menu.

CODE	CONTENTS	CAUSE	ACTION
0109	Even though the machine carries out the regular movement, the output of the Wiper Sensor does not reach the expected value.	Wiper Motor error Defect of Wiper Unit Defect of Wiper Sensor Cut-line or short-circuit of cable and Flexible cable	Wiper Motor Replacement Wiper Unit Replacement Wiper Sensor Replacement Cable and Flexible cable Replacement
0110	Input value from Linear Encoder is not changed by the Linear Encoder origin setup. When Motor stops during printing, expected movement is not completed on some head.	Read error of Linear Encoder. Read error of Encoder on Scan Motor side. Belt is not fixed to Head Carriage firmly.	Confirm whether Encoder Scale is between the slit of Encoder Module in a whole width of the machine. Check cable connection between Linear Encoder Board and Main Board. Confirm connection between Belt and Carriage. Linear Encoder replacement Scan Motor replacement Main Board replacement
0111	This error occurs when the machine performs the Auto Crop Mark Detection	Crop-Cut Adjustment in the Service menu has not been performed.	Carry out Crop-Cut Adjustment in service menu.
0112	Communication error with Cartridge IC driver	Cartridge IC driver is broken. Cartridge IC driver cable has short circuited or cut-line.	Ink cartridge IC sensor replacement
0130	There is a problem with Thermistor for Print Heater	Thermistor cable has short circuited or cut-line. Thermistor has a problem.	Check cable connection around Thermistor. Thermistor replacement
0135	Print Heater temperature has reached 60°C and above	Print Heater cable connection has a problem. Thermostat has a problem. Thermistor has a problem.	Check Print Heater Check Thermostat Check Thermistor
0140	There is a problem with Thermistor for dryer	Thermistor cable has short circuited or cut-line. Thermistor has a problem.	Check cable connection around Thermistor Thermistor replacement
0145	Dryer temperature has reached 80°C and above	Dryer cable connection has a problem. Thermostat has a problem. Thermistor has a problem.	Check Dryer Check Thermostat Check Thermistor

7 Service Activities

7-1 INSTALLATION CHECK LIST

VP-540/300 INSTALLATION CHECK LIST

Date : _____

User Name : _____

Serial Number : _____

Checking for Installing Place

- There is a space necessary for installing the machine as follows.

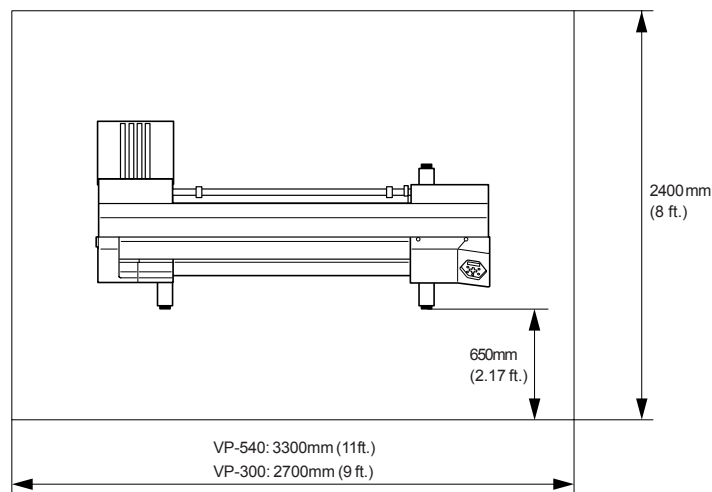

- Install the machine in a location that is level, stable, and able to bear the weight of the machine. The total weight of the machine may reach 160 kg (353 lb.) or more (120 kg (265 lb.) or more for the 30-inch model). Installation in an unsuitable location may cause a major accident, including tipover, fall, or collapse.
- Never install out of doors or in any location where exposure to water or high humidity may occur. Current leakage may cause electrical shock, electrocution, or combustion and fire.
- Never install close to any flammable object or in a gas-filled location. It causes a risk of combustion or explosion.
- Install in a clean, brightly lit location. Conduct operations in a clean, brightly lit location. Working in a location that is dark or cluttered may lead to an accident, such as becoming caught in the machine as the result of an inadvertent stumble.
- Position so that the power plug is within immediate reach at all times. This is to enable quick disconnection of the power plug in the event of an emergency. Install the machine next to an electrical outlet. Also, provide enough empty space to allow immediate access to the electrical outlet.
- Ensure adequate ventilation for the work area. Failing to perform ventilation may result in a health hazard or danger of combustion due to ink fumes.

Unpacking

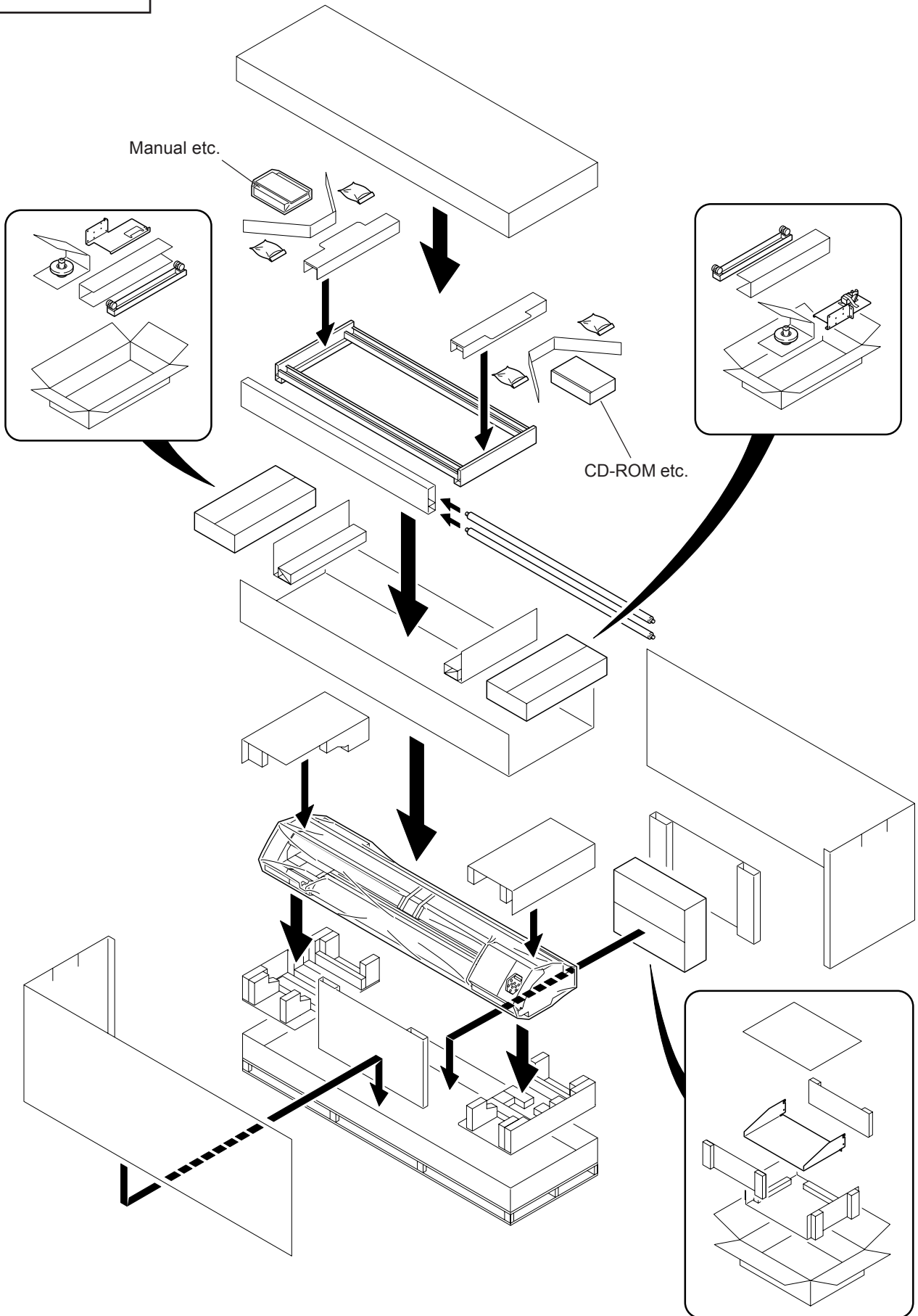

Checking the Accessories

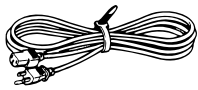

Power cord: 1

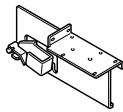

Arm (right): 1

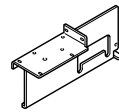

Arm (left): 1

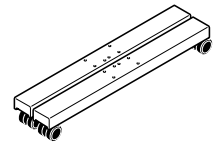

Casters: 2

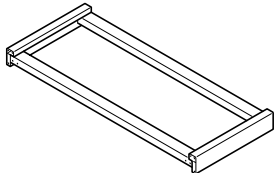

Stand leg: 1

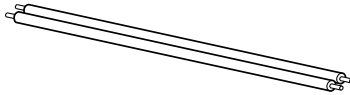

Shafts: 2

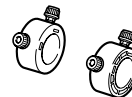

Stoppers: 2



Bolts : 26



Hexagonal wrench: 1



Pipe: 1

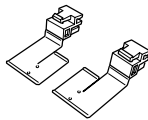

Short media clamps : 2
(left and right)
* Installed on the machine

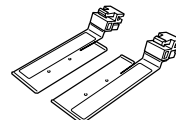

Long media clamps : 2
(left and right)

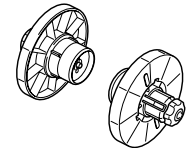

Media flanges: 2

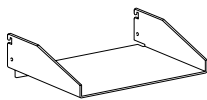

Ink-cartridge tray: 1

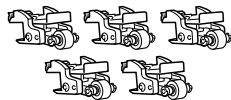

Middle pinch rollers:
5 (VP-540)
2 (VP-300)
* Installed on the machine



Blade: 1

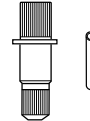

Blade holder: 1
Pin:1



Replacement blade for separating knife: 1

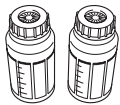

Drain bottles: 2

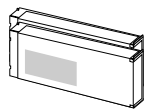

SOL INK cleaning cartridges: 2

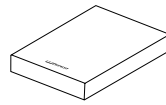

Software RIP: 1

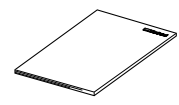

User's Manual: 1

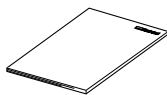

Setup Guide: 1

Cleaning kit



Cleaning sticks: 10



Tweezers: 1

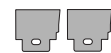

Replacement wipers: 2

Installation and Preparation

Set up following items in reference to the Setup Guide [3.Assembling and Installing] to [7. Network Settings].

- Assemble the Stand
- Attach the Shafts
- Install the Drain Bottle

Revised 1

!! IMPORTANT!!
Be careful not to pinch the drain tube.

VP-540 : ZV71196 and below
VP-300 : ZV70554 and below

VP-540 : ZV71197 and above
VP-300 : ZV70555 and above

- Attach the Ink-cartridge Tray
- Remove the Packing Materials
- Connect the Cables
- Install the Ink Cartridges

!! IMPORTANT!!
Shake the Ink Cartridge a few times gently before installing to the machine.

- Install the Blade
- Make the Network Settings

IP address of PC _____

Revised 1

IP address of VP-540/300 _____

Upgrading the Firmware

Upgrade the firmware to the latest version.

Revised 5

Setting Date and Time

Go to SERVICE MENU > SUB MENU > CLOCK and set date and time to the local time.

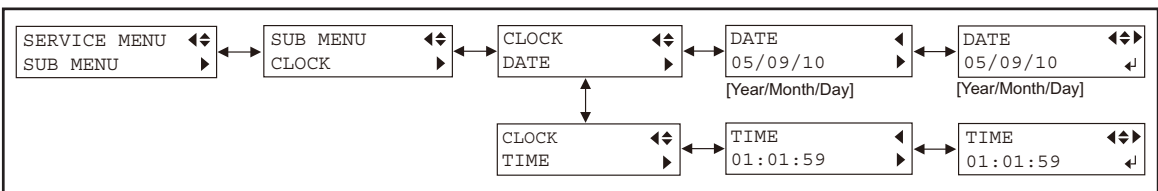

Installing Roland Versaworks

Install Roland VersaWorks in reference to the Quick Start Guide.

System requirements for installing the software

Operating system : Windows XP Professional Service Pack 1 or later,
or Windows 2000 Service Pack 4 or later
CPU : Pentium 4 2.0 GHz or faster
Memory (RAM) : 512MB and above (1GB or more recommended)
Monitor : High-resolution SXGA (1,280 x 1,024 pixels) or better display recommended
Free hard-disk space required as a working space : 40 GB or more recommended
Hard-disk file system : NTFS format

- Make the setting for Roland@NET
Select the check box [Download Updates Automatically and Notify] if the customer accepts it.
- Power-saving setting on PC
Turn off the PC's Power-saving functions which make the PC goes stanby or sleep. It may stop a job being output.

Basic Operation

Explain following items in reference to the User's Manual.

- Switching the power on and off

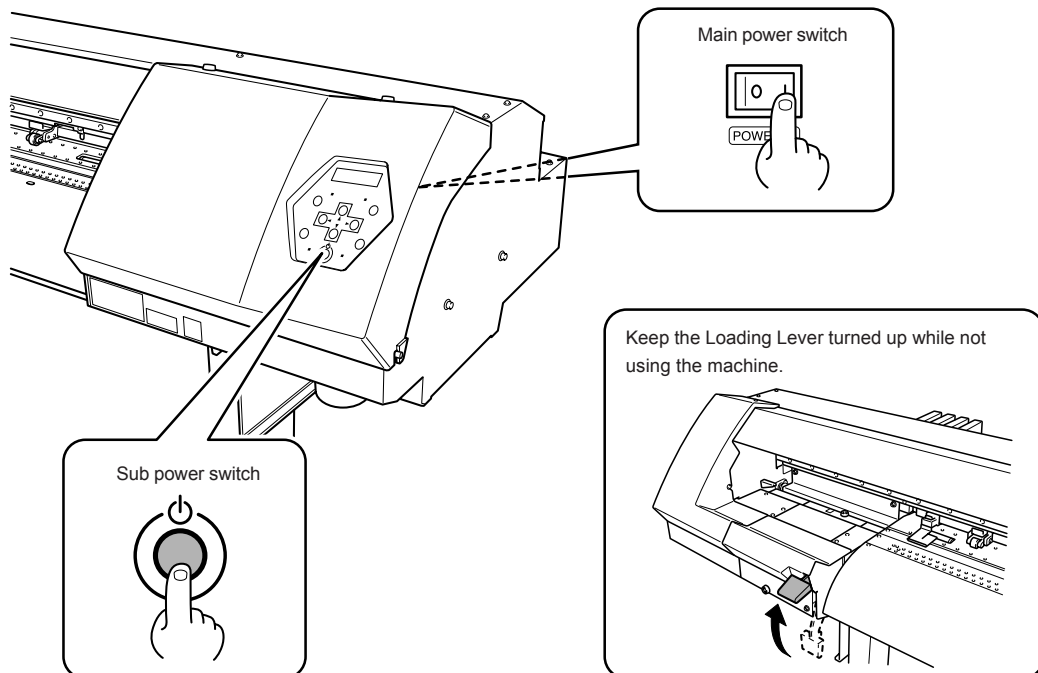

!! IMPORTANT !!

Leave the main power on at all times. Maintenance operation is automatically carried out every 24 hours while the machine is not in use. Use the sub power switch for the daily powering on and off.

Loading and cutting off media



For the stable media feeding, place the middle pinch rollers above all the grit rollers that lie between the left and right pinch rollers.

!! IMPORTANT !!

Performing a sheet cut when the long media clamps are installed causes interference with the separating knife, which may result in malfunction or damage to the machine. When you use the long media clamps, set the [MEDIA CLAMP] menu item to [LONG] to disable the sheet cut.

Settings for the Media Heating System

!! IMPORTANT !!

Do not set the print heater temperature too high. If the ink dries too fast, the diameter of the ink dots land on the media cannot expand enough and it may result in bandings.

Starting printing or cutting

- Pausing and canceling a printing or cutting
- Setting a starting position of printing or cutting (Base posint setting)

Printing test and cleanings

- Test print
- Normal cleaning
- Medium cleaning
- Powerful cleaning



Large amount of ink is consumed for the Powerful cleaning.

Checking for remaining Ink

- Explain the [EMPTY MODE].

!! IMPORTANT !!

The remaining ink amount shown on the machine and RIP is only an approximate guide, which may differ somewhat from the actual amount remaining.

Installation & Handling of the ink cartridges

!! IMPORTANT !!

- Shake the cartridge gently before installing a ECO-SOL MAX ink cartridge.
- Be sure to replace with an item of identical type. Never mix items of different types.
- Never leave the machine with any ink cartridge removed. The print heads may become clogged.
- Never frequently insert and remove an ink cartridge. Air may leak into the ink tube and be a cause of missing dots.
- When printing is paused, the coloring at the seam may be altered when printing resumes. Before you perform lengthy printing, check the amount of ink remaining in the ink cartridges.
- Never store ink at any locations where high temperature may occur or exposed to open flame.

Performing a cutting

- Test Cut
- [CUTTING PRIOR] menu
- Adjusting the cutting conditions (Blade Force, Cutting Speed, Blade Offset, Tool-up Speed)

Job outputting from Roland VersaWorks

Explain each procedure as follows on a job outputting from Roland VersaWorks.

Printing

Cutting

!!IMPORTANT!!

Never use the Media Clamps during cutting.

Printing and cutting



During a print & cut, the cap of the cutter holder may scratch and damage the printed surface. Turn the cap of the blade holder to adjust the amount of blade extension or use the Dry Time setting on RIP as necessary.

Printing and cutting using Crop Marks
(Refer to the User's Manual[4-9 Performing Printing and Cutting Separately])

- Automatic alignment with Crop Marks
- Manual alignment with Crop Marks



When printing and cutting are performed using Crop Marks, misalignment of cutting caused by media stretch/shrinkage can be avoided.

Adding Media Profiles

Explain the procedure of adding Media Profiles of third-party media.

Downloading Media Profiles from the website.

Adding Media Profiles to Roland VersaWorks.

Functions for optimizing printing and cutting

Explain the following items referring to the User's Manual.

Optimizing printing to match Media thickness

- Head height (VP-540 only)
- Bi-direction adjustment
- Feed calibration

!! IMPORTANT !!

- These adjustments are required for each Media individually.
- If you are setting Feed Calibration on your machine, check in advance that [Use Printer Settings] is set on Roland VersaWorks.



Optimizing printing and cutting to match Media thickness

- Bi-direction adjustment
- Print/Cut position adjustment

!! IMPORTANT !!

- These adjustments are required for each media and also when the head height is changed.
- Make sure to perform Bi-direction adjustment before Print/Cut position adjustment.

Correcting misalignment for printing and cutting when using Crop Marks

- Bi-direction adjustment
- Crop-Cut adjustment

!! IMPORTANT !!

- These adjustments are required when printing and cutting using Crop marks are not aligned.
- Make sure to perform Bi-direction adjustment before Crop-Cut adjustment.

[AUTO ENV.MATCH] function

!! IMPORTANT !!

This function is for correcting the Print & Cut misalignment caused by the stretch/shrinkage of Encoder Scale. Make sure to set it to [ENABLE] at all times.

Calibration for cutting

!! IMPORTANT !!

During Print & Cut, [CALIBRATION] in the [CUTTING MENU] is to be set to [0]. It may cause a misalignment of printing and cutting. This calibration is to be used only when performing cutting only.

Preset function

All menu items listed below can be saved in Presets. It is useful to have saved settings that are different by media.

- Temperature setting of Heater/Dryer
- [EDGE DETECTION]
- [SCAN INTERVAL]
- [VACUUM POWER]
- [FULL WIDTH S]
- [FEED FOR DRY]
- [CALIBRATION] (in the [CUTTING MENU])
- Cutting conditions
- [ADJUST BI-DIR]
- [CALIBRATION] (for printing)
- [PRINT-CUT ADJ.]
- [CROP-CUT ADJ.]
- [PREHEATING]

Maintenance

Explain the following items referring to the User's Manual.

Disposing of discharged ink

[CHECK DRAIN BOTTLE] message appears when a certain amount of discharged fluid collects in the bottle.

!! IMPORTANT !!

- When you dispose of discharged ink, make sure to reset the discharged-fluid count from [MENU] > [SUB MENU] > [MAINTENANCE] > [DRAIN BOTTLE] and press the [ENTER] key. Otherwise, "CHECK DRAIN BOTTLE" message appears at the inappropriate timing.
- Never place discarded fluid in the location close to fire.
- To store discharged fluid temporarily, use the included drain bottle or durable sealed container such as a metal can or polyethylene tank, and cap it tightly.
- Dispose of discharged fluid properly, in accordance with your local laws.

Cleaning the parts other than the print heads

- Pinch Rollers
- Grit Rollers
- Platen

!!IMPORTANT!!

Never use gasoline, alcohol, thinner, or any other flammable materials.

Cleaning using the cleaning kit

!!IMPORTANT!!

This is very important work for maintaining the heads in good condition and must be done periodically.

Replacing the wipers

Replacing the blade

Replacing the separating knife

Explain the following items referring to the Setup Guide.

Temperature and humidity

Specified temperature and humidity must be maintained even while not in use. When the temperature is too high, the alteration of ink may damage the machine. And, when it is too low, frozen ink may damage the print heads.

While in use: Temperature 20 to 32°C, Humidity 35 to 80% (Non-condensing)

While not in use: Temperature 5 to 40°C, Humidity 20 to 80% (Non-condensing)

When not in use for a prolonged period

Transporting the unit

When transporting the unit, head cleaning is required and you need 2 cleaning cartridges for it.

!!IMPORTANT!!

Fill ink within one week after transporting. If the machine is left without ink, the nozzles on the heads may get clogged.

Others

Explain to refer to the User's Manual when a error message is displayed. And also explain to switch off and on the machine and check what happens before calling for inquiry when [SERVICE CALL] is displayed, since it occasionally solves the problem just by restarting.

Explain the procedure of capping the print heads referring to the User's Manual [5-5 The Print Heads Stopped Moving]. When the print carriage does not return to the standby position, capping needs to be done manually by user.

Consumable Parts and
Replacement Cycle

Parts Name	Replacement Cycle
Printing Head	6 billion shots / nozzle (6,000,000 kshots) * Damper needs to be replaced together with the Head replacement.
Wiper	6 months, Wiping 3000 times or Rubbing 100 times
Carriage Motor	1500 hours
Cap Top	6 months
Ink Tube	3000 hours
Sponge for Wiper	12 months
Lithium Battery	24 months
Cutter Protection	Replace it depending on the degree of scratches on it.
Pinch Roller	Replace it depending on the degree of wear of its rubber part.

7-2 Maintenance Check List

VP-540/300 Maintenance Check List

Date : _____

User : _____

Serial Number : _____

Check Items		Operation Points	Check
Interview the customer		Ask the customer if there is something that he/she is concerned about.	<input type="checkbox"/> Done
Output / Get report before maintenance		Get report with [Get Report] of the Peck, or print [ALL] Report in the Service menu.	<input type="checkbox"/> Done
Check drain bottle		If large amount of ink is discharged in the drain bottle, dispose of it and give an explanation to the customer. Make sure to reset the discharged-ink count.	<input type="checkbox"/> Good <input type="checkbox"/> Disposed <input type="checkbox"/> Reset
Upgrade the firmware to the latest version		Upgrade the firmware if the installed firmware is not the latest version.	<input type="checkbox"/> OK
Check Consumable Parts	Head	Determine if they should be replaced based on the SHOT COUNT in the History Report, the test print result and the customer's interview. Replacement Cycle : 6 billion shots/Nozzle	<input type="checkbox"/> Good <input type="checkbox"/> Replacement Done <input type="checkbox"/> Reset
		Perform a manual cleaning by using cleaning sticks and cleaning liquid.	<input type="checkbox"/> Cleaning Done
		Output the test patterns for BIAS, VERTICAL, HORIZONTAL and BI-DIR. DEFAULT to check the error, and perform adjustment if necessary.	<input type="checkbox"/> Good <input type="checkbox"/> Adjustment
	Carriage Motor	Determine if it should be replaced based on MOTOR ERROR and MOTOR HOURS S in the History Report, the motor sound heard while printing the report and the customer's interview. Put some grease (FLOIL G902) on the gear if you replace the motor. Replacement Cycle : 1,500 hours	<input type="checkbox"/> Good <input type="checkbox"/> Replacement Done <input type="checkbox"/> Reset
	Cleaning Wiper	Determine if it should be replaced based on the deformation or the time period from the last replacement. If replacement is unnecessary, clean them manually using the Roland cleaning stick and cleaning liquid. Replacement Cycle : 6 months, Wiping count 3,000 times or Rubbing count 100 times.	<input type="checkbox"/> Cleaning Done <input type="checkbox"/> Replacement Done
	Cap Top	Determine if it should be replaced based on the performance of the cleaning or the time period from the last replacement. If replacement is unnecessary, clean them manually using the Roland cleaning stick and cleaning liquid. Replacement Cycle : 6 months	<input type="checkbox"/> Good <input type="checkbox"/> Cleaning Done <input type="checkbox"/> Replacement Done
	Sponge for Wiper	Determine if it should be replaced based on its appearance or the time period from the last replacement. Replacement Cycle : 12 months	<input type="checkbox"/> Good <input type="checkbox"/> Replacement Done
	Wiper Scraper	Clean it manually using the Roland cleaning stick and cleaning liquid. Replace it as necessary.	<input type="checkbox"/> Cleaning Done <input type="checkbox"/> Replacement Done
Lithium Battery	Replacement Cycle : 24 months	<input type="checkbox"/> Good <input type="checkbox"/> Replacement Done	
Check Mechanical Parts	Carriage Belt	Check if the carriage belt doesn't touch the the flanges of the drive pulley and idle pulley when the head carriage moves in the full width. Adjust the belt position, if necessary.	<input type="checkbox"/> Good <input type="checkbox"/> Adjustment Done
		Check the belt tension and adjust it if necessary.	<input type="checkbox"/> Good <input type="checkbox"/> Adjustment Done
	Pinch Roller	Check if it is not worn out, it does not have dirt on it and it rotates smoothly.	<input type="checkbox"/> Good <input type="checkbox"/> Replacement Done
	Grit Roller	Remove foreign substances stuck on it by using a brush.	<input type="checkbox"/> Done
Cutter Protection	Replace it depending on degree of scratches on it.	<input type="checkbox"/> Good <input type="checkbox"/> Replacement Done	
Check printing		Check that there is no problem with the printing operation and printing result.	<input type="checkbox"/> Done
Check cutting		Check that there is no problem with the cutting operation and cutting result.	<input type="checkbox"/> Done
Output / Get report after maintenance		Get report with [Get Report] of the Peck, or print [ALL] Report in the Service menu.	<input type="checkbox"/> Done

7-3 Specifications

Main unit specification

		VP-540	VP-300
Printing technology		Piezoelectric inkjet	
Media	Width	210 to 1,371 mm (8.3 to 54 in.)	182 to 762 mm (7.2 to 30 in.)
	Thickness	Maximum 1.0 mm (39 mil) with liner, for printing Maximum 0.4 mm (16 mil) with liner and 0.22 mm (9 mil) without liner, for cutting	
	Roll outer diameter	Maximum 180 mm (7 in.)	
	Roll weight	Maximum 30 kg (66 lb.)	Maximum 20 kg (44 lb.)
	Core diameter	50.8 mm (2 in.) or 76.2 mm (3 in.)	
Printing/cutting width (*1)		Maximum 1,346 mm (53 in.)	Maximum 736 mm (29 in.)
Ink cartridges	Types	220-cc cartridge / 440-cc cartridge	
	Colors	Four colors (cyan, magenta, yellow, and black)	
Printing resolution (dots per inch)		Maximum 1,440 dpi	
Cutting speed		10 to 300 mm/s	
Blade force		30 to 200 gf	
Cutting blade	Type	Roland CAMM-1 series compatible	
	Blade offset	0 to 1.5 mm (0 to 0.059 in)	
Software resolution (when cutting)		0.025 mm/step	
Distance accuracy (when printing) (*2) (*3)		Error of less than 0.3% of distance traveled, or 0.3 mm, whichever is greater	
Distance accuracy (when cutting) (*3)		Error of less than 0.4% of distance traveled, or 0.3 mm, whichever is greater When distance correction has been performed (when the setting for [CALIBRATION] - [CUTTING ADJ.] has been made): Error of less than 0.2% of distance traveled, or 0.1 mm, whichever is greater	
Repeatability (when cutting) (*3) (*4)		0.1 mm or less	
Alignment accuracy for printing and cutting (*3) (*5)		0.5 mm or less	
Alignment accuracy for printing and cutting when reloading media (*3) (*6)		Error of less than 0.5% of distance traveled, or 3 mm, whichever is greater	
Media heating system (*7)		Print heater, setting range for the preset temperature: 30 to 45°C (86 to 112°F) Dryer, setting range for the preset temperature: 30 to 50°C (86 to 122°F)	
Connectivity		Ethernet (10BASE-T/100BASE-TX, automatic switching)	
Power-saving function		Automatic sleep feature	
Power requirements		AC 100 to 120 V 10%, 8.3 A, 50/60 Hz or AC 220 to 240 V 10%, 4.3 A, 50/60 Hz	AC 100 to 120 V 10%, 5.8 A, 50/60 Hz or AC 220 to 240 V 10%, 3.0 A, 50/60 Hz
Power consumption	During operation	Approx. 1,110 W	Approx. 780 W
	Sleep mode	Approx. 34 W	Approx. 33W
Acoustic noise level	During operation	64 dB (A) or less (according to ISO 7779)	64 dB (A) or less (according to ISO 7779)
	During standby	40 dB (A) or less (according to ISO 7779)	40 dB (A) or less (according to ISO 7779)
Dimensions (with stand) (*8)		2,310 (W) x 740 (D) x 1,125 (H) mm (90.9 (W) x 29.1 (D) x 44.3 (H) in.)	1,700 (W) x 740 (D) x 1,125 (H) mm (66.9 (W) x 29.1 (D) x 44.3 (H) in.)
Weight (with stand)		109 kg (240 lb.)	87.5 kg (193 lb.)
Environmental	Power on (*9)	Temperature: 15 to 32°C (59 to 90°F) (20°C [68°F] or more recommended), humidity: 35 to 80%RH (non-condensing)	
	Power off	Temperature: 5 to 40°C (41 to 104°F), humidity: 20 to 80%RH (non-condensing)	
Accessories		Exclusive stands, power cord, blade, blade holder, media clamps, media flanges, replacement blade for separating knife, cleaning kit, software RIP, User's Manual, etc.	

*1
The length of printing or cutting is subject to the limitations of the program.

*2
With Roland PET film, print travel: 1 m
Temperature: 25°C (77°F), humidity: 50%

*3

Not assured when the print heater or dryer is used.

*4

The following conditions must be met:

Media type: Media specified by Roland DG Corp.

Roll media must be loaded on the shaft.

[PREFEED] menu item must be set to "ENABLE."

Side margins: 25 mm or more for both the left and right margins

Front margin: 35 mm or more

Excluding expansion/contraction of the media

Range for assured repetition accuracy

54-inch model

For media with a width exceeding 610 mm: Length 4,000 mm

For media with a width of 610 mm or less: Length 8,000 mm

30-inch model

Length 3,000 mm

*5

Provided that media length is under 3,000 mm

Temperature: 25°C (77°F)

Excluding possible shift caused by expansion/contraction of the media and/or by reloading the media.

*6

Media type : Roland PET film

Data size: 1,000 mm in the media-feed direction, 1,346 mm (54-inch model) or 736 mm (30-inch model) in the carriage-move-ment direction

No lamination

Automatic detection of crop marks at 4 points when media is reloaded.

During cutting, [PREFEED] menu item must be set to "ENABLE."

Temperature: 25°C (77°F)

Excludes the effects of slanted movement and of expansion and contraction of the media.

*7

Warm-up is required after powerup. This may require 5 to 20 minutes, depending on the operating environment.

Depending on the ambient temperature and media width, the preset temperature may fail to be reached.

*8

Depth when the included ink-cartridge tray is installed is 1,000 mm.

*9

Operating environment

