

CJV30 *Series*
TPC-1000

CJV30- 60/100/130/160
TPC-1000

MAINTENANCE MANUAL

Maintenance Manual Change Tracking

Date	2010.11.05	Manual Ver.	1.30	Remark	
Status	Index	Rev.	Changes		
Modified	1.3.1	1.2	Flow of ink supply control is moved to the next page		
Modified	1.3.1	1.1	7-color ink set and 8-color ink set is added		
Added	1.3.1	1.0	7-color ink set and 8-color ink set is added to ink system configuration		
Modified	1.3.2	1.2	No.18 is added		
Modified	1.3.3	1.2	7-color ink set and 8-color ink set is added		
Modified	1.3.4	1.1	REINSERT CARTRIDGE is added		
Modified	1.3.6	1.3	"Updating of the amount of remaining ink" is move to next page		
Modified	1.3.6	1.2	Table is added		
Modified	1.3.9	1.2	8-colors setting value is added		
Modified	1.3.11	1.0	Added		
Modified	2.2.1	1.2	Color is added		
Modified	4.2.13	1.1	Step2: LCD display is changed		
Modified	5.1.1	1.3	6-color+W, 7-color, 8-color are added		
Modified	5.1.2	1.3	6-color+W, 7-color, 8-color are added		
Modified	5.1.3	1.2	6-color+W, 7-color, 8-color are added		
Modified	5.2.5	1.1	7-color, 8-color are added		
Modified	6.2.9	1.2	7-color, 8-color are added		
Modified	7.1.2	1.3	No.120: Remedy id changed No.208: Added		
Modified	7.1.3	1.3	No.49: Added No.50: Added		
Modified	8.2.1	1.1	Changed		
Modified	8.2.2	1.2	Changed		
Modified	8.2.3	1.2	Changed		
Added	8.2.3	1.0	Changed		
Modified	8.3.1	1.1	Changed		
Added	8.3.1	1.0	Changed		
Modified	8.3.2	1.2	Changed		
Modified	8.3.3	1.2	Changed		
Modified	8.2.4	1.2	Changed		
Modified	8.3.1	1.1	Changed		
Added	8.3.1	1.0	Changed		
Modified	8.3.2	1.2	Changed		
Modified	8.3.3	1.2	Changed		
Modified	8.4.1	1.1	Changed		

Date	2009.07.30	Manual Ver.	1.20	Remark	
Status	Index	Rev.	Changes		
	1.2.10	Added	1.0	"Aqua->Sol EXCHG" was added.	
	1.3.3	Modified	1.1	The change of order of priority for cartridge.	
	1.3.3	Added	1.0	"Regarding the order of priority when using MBIS1" is added.	
	1.3.10	Added	1.0	"Ink expiry month and extend expiry month" is added.	
	5.2.1 ~ 5.2.6	Modified	1.1	Added information to refer to [4.5.2 Electric charge checking when replace the Electrical Parts] regarding Warning.	

Maintenance Manual Change Tracking

Date	2009.07.30	Manual Ver.	1.20	Remark	
Status	Index	Rev.	Changes		
6.5.1 ~ 6.5.16	Modified	1.X	Added information to refer to [4.5.2 Electric charge checking when replace the Electrical Parts] regarding Warning.		
6.5.17	Added	1.0	New item "Replacement procedure for fuse of the Main PCB" was added.		
7.1.2	Modified	1.3	Error 205 was added. Error 207 was added.		
7.1.3	Added		List of Warning Messages Added, Reviewed.		
7.2.3	Modified	1.3	The description of "Print head breakage details" is changed.		
7.2.5	Added	1.0	New item "Heater temperature does not going up" was added.		
8.2.3	Modified		Operation Flow "Aqua->Sol EXCHG" was added.		
8.2.4	Modified		Operation Flow "CART.PRIORITY" was added.		

Date	2009.06.30	Manual Ver.	1.20	Remark	
Status	Index	Rev.	Changes		
all	Added		<ul style="list-style-type: none"> TPC(-1000) was added. "sheet" and "paper" were replaced to "media". (4.2.8, 4.2.9, 4.2.10, 4.2.11, 4.2.12, 5.1.1, 5.1.2, 5.1.3, 5.1.5, 5.1.6, 5.1.7, 5.1.36, 7.1.2, 7.1.3) 		
1.3.1	Added	1.1	Note for TPC was added.		
1.3.6	Added	1.2	TPC-1000 was added on the table.		
2.2.1 4.2.6 4.2.19 6.2.9 7.1.4	Modified	1.1	Model name was changed to "this machine".		
4.2.8 4.2.9 4.2.10	Modified	1.1 1.2 1.2	Description of pen line film was deleted.		
4.2.11	Added	1.2	Description was added on "Important".		
4.2.12	Added	1.1	Description was added on "Important".		
5.1.1	Modified	1.2	On step6, Sublimation5 was changed to "Sb51, Sb52".		
5.2.1	Added	1.0	New item [Determining COM short circuit] was added.		
5.2.2	Added	1.0	New item [Checking Damage of the Print Heads] was added.		
5.2.3	Added	1.0	New item [Checking Damage of the Main PCB ASSY] was added.		
5.2.4	Added	1.0	New item [Checking Damage of the Ink Slider PCB] was added.		
5.2.5	Added	1.0	New item [Checking Conduction of HDC FFC COM Line] was added.		
5.2.6	Added	1.0	New item [Checking Conduction of HDC FFC Data Line] was added.		
6.5.2	Modified	1.2	Description of Hint was changed.		
7.1.1	Added	1.1	On the figure, "Refer to 7.2" was added.		
7.1.2 P1	Added	1.2	Added information to refer to [7.2.3 Electrical Troubleshooting] regarding Error 07.		
7.1.2 P5	Added	1.2	Added information to refer to [7.2.3 Electrical Troubleshooting] regarding Error 205.		
7.1.4	Added	1.0	New item [Y belt derailment or damage] was added. New item [The power cannot be turned on], [Abnormal discharging] was added.		
7.2.3	Added	1.0	New item [Electrical Troubleshooting] was added.		
7.2.4	Added	1.0	New item [Y Drive Belt Damage] was added.		

Date	2008.12.06	Manual Ver.	1.20	Remark	
Status	Index	Rev.	Changes		
7.1.2 P3	Added	1.2	Added information to refer to [7.2.2 Media Attachment to the Platen] regarding Motor Error.		
7.1.4	Added	1.0	New item [Trouble with No Messages] was added.		

Maintenance Manual Change Tracking

Date	2008.12.06	Manual Ver.	1.20	Remark	
Status	Index	Rev.	Changes		
7.2.1	Added	1.0	New item [Y Drive Belt Noise] was added.		
7.2.2	Added	1.0	New item [Media Attachment to the Platen] was added.		

Date	2008.09.17	Manual Ver.	1.10	Remark	
Index	Status	Rev.	Changes		
1.1.1	Revised	1.10	[Indication on LCD] “DPC” → “PDC”		
	Revised	1.10	[Indication on LCD] “V1.00” → “V1.00.0”		
	Added	1.10	Step 6: “When the fuse F13 of the main PCB assy is blown, ...”		
1.1.2	Revised	1.10	[Indication on LCD] “DPC” → “PDC”		
	Revised	1.10	[Indication on LCD] “V1.00” → “V1.00.0”		
	Added	1.10	Step 4: “When the fuse F13 of the main PCB assy is blown, ...”		
	Added	1.10	Step 5: “(Except firmware update)”		
1.1.3	Added	1.10	Step 4: “(Only when MAIN power is on)”		
	Added	1.10	Step 5: “(Refer to “1.1.6 Operation for Connecting the Heads”)”		
1.1.4	Revised	1.10	Step 2, 4: “When it cannot be detected ...” → “When detection is impossible or the number of pinch rollers is not recognized, ...”		
	Added	1.10	Tips Box: “(Only during Step 3 above)”		
1.1.5	Revised	1.10	Tips Box: “[PRINT MODE] ↔ [CUT MODE] was switched.” → “The machine draws a stored pattern which can be selected ...”		
1.1.8	Added	1.10	Tips Box: “In service mode, the buzzer sounds ...”		
1.2.3	Added	1.10	Step 3: “Press [FUNCTION], and the maintenance washing liquid ...”		
1.2.9	Revised	1.10	[Indication on LCD]: All the indications on the display revised		
	Revised	1.10	Description of status No1-1: “... near full or more.” → “... full or more.”		
	Erased	1.10	Step 2: “The [!WASTE TANK] is displayed in LOCAL mode.”		
	Revised	1.10	Important Box: “... is cumulatively counted in this unit.” → “... is not cumulatively counted in this unit.”		
1.3.2	Revised	1.10	In Table: “Execution status when an error occurs” (5, 6, 7, 8)		
1.3.6	Revised	1.10	In Table: “Ink consumption through one supply path”		
1.3.9	Erased	1.10	Item: “Selection of model”		
2.1.1	Revised	1.10	“Connection Diagram Inside the Main Body” revised		
2.3.1	Added	1.10	Volume specification: “Type”		
	Added	1.10	Fuse rating		
2.3.2	Added	1.10	Fuse rating		
2.3.6	Revised	1.10	List of connectors CN7: “AUX.” → “P Head Lock Solenoid”		
2.3.7	Revised	1.10	List of connectors CN19: “Debug Monitor” → “Not equipped” “CPLD writing” → “AUX.”		
	Revised	1.10	List of connectors CN21: “X-axis Motor” → “AUX.”		
2.3.8	Revised	1.10	List of connectors CN14: “Debug Connector” → “None”		
	Added	1.10	List of connectors CN14: “AUX.”		
2.3.11	Revised	1.10	List of connectors CN2: “For CPLD writing” → “None”		
	Added	1.10	List of connectors CN2: “AUX.”		
3.1.1	Revised	1.10	Item: “Cartridge Assy” → “Print Head Unit Assy”		

Maintenance Manual Change Tracking

Date	2008.09.17	Manual Ver.	1.10	Remark	
Index	Status	Rev.	Changes		
3.1.2	Revised	1.10	Work operation 1: "station cover U and ..." → "station cover U, W ink guard and ..."		
	Revised	1.10	Work operation 3: "... while it is pressed against the innermost part." → "... while pushing it toward you."		
3.1.3	Revised	1.10	Work operation 1: "Remove the ICU cover F, ICU cover R, ..." → "Remove the ICU cover, ..."		
3.1.4	Revised	1.10	Section changed: "3.3. Driving Parts" → "3.1. Ink Related Parts"		
	Revised	1.10	Work operation 1: "... C station cover." → "... C station cover 2."		
3.2.1	Added	1.10	Work operation 4: "In installation, pay attention to harness treatment."		
	Revised	1.10	Work operation 7: "7.0 mm" → "8.8 mm"		
		1.10	Work operation 8 to 10: The order of work items changed and items added		
3.2.2	Revised	1.10	Work operation 1: "... auto cutter assy." → "... S guide."		
		1.10	Work operation 4: "7.0 mm" → "8.8 mm"		
	Added	1.10	Work operation 4: "(If necessary, check to see if the magnet catcher..."		
		1.10	Work operation 6: "Install the S guide while pushing it to the left."		
Erased	1.10	Caution Box: "Be sure to wear protective glasses and working gloves..."			
3.2.3	Added	1.10	Work operation 4: "Set the pressure of all the clamps to Middle,..."		
	Revised	1.10	Work operation 6: "Adjust the pen stroke at..." → "Adjust so that the pen stroke is..."		
		1.10	Work operation 7: "7.0 mm" → "8.8 mm"		
	Added	1.10	Work operation 11, 12		
1.10		Important Box: "Once the S guide is removed, ..."			
3.3.2	Added	1.10	Work operation 1: "...and D BKT cover."		
3.3.3	Erased	1.10	Work operation 4: "Greasing of Y drive belt"		
3.3.5	Added	1.10	Work operation 5: "GR/PR adjustment"		
		1.10	Work operation 6: "Install all the covers temporarily first ..."		
3.4.1	Revised	1.10	Work operation 3/4: "Mounting" / "Removal"		
	Erased	1.10	Caution Box: "Be sure to wear protective glasses and working gloves..."		
4.1.1	Erased	1.10	Adjustment item: Adjustment of light pointer offset Adjustment of cutting position Work contents: Pulley BTG removal or replacement Paper sensor		
4.2.2	Added	1.10	Tips Box: "The same adjusted value is applied to..."		
4.2.3	Added	1.10	Important Box: "Make adjustment with [EXPANDS] of..."		
	Erased	1.10	Tips Box: "If the unit is changed to inch,..."		
4.2.5	Revised	1.10	Adjustment procedure 4: "Vertically shifts the cap." → "Shifts the cap."		
		1.10	Adjustment procedure 5: "Horizontally shifts the head." → "Horizontally shifts the wiper."		
4.2.8	Page deleted	–	"Remarks" and "Examples of inputting a compensation value"		
4.2.9	Revised	1.10	Function: "400g" → "350g"		
			Procedure 6: "400g" → "350g"		
4.2.10	Revised	1.10	Function: "Plots 11 square patterns using the 11 pen landing values of 0 to 200, respectively. (20 steps)" → "Plots 11 square patterns at the positions of different pen landing values in steps of 20, starting at the first pen landing point."		
	Added	1.10	Function (The content of adjustment...): "#LANDING UP POSITION"		
	Added	1.10	Procedure 3 to 6: Because of addition of "#LANDING UP POSITION"		
	Revised	1.10	Procedure 7: "... the 11 pen landing values (0, 20, 40 ... 200) of 0 to 200 currently being set." → "... different pen landing values in steps of 20, starting with the currently set pen landing value."		

Maintenance Manual Change Tracking

Date	2008.09.17	Manual Ver.	1.10	Remark	
Index	Status	Rev.	Changes		
4.2.11	Added	1.10	Tips Box: "Pressing [FUNCTION] will release..."		
4.2.14	Revised	1.10	Function: "If a hunting noise is heard when the X-axis motor and ..." → "If hunting occurs or a hunting noise is heard when the X-axis motor and/or ..."		
	Added	1.10	Procedures for STOP ADJUST 2: Key operation (ENTER, END)		
	Erased	1.10	Procedures for STOP ADJUST 2 (LCD side): "Motor rotation"		
	Revised	1.10	Procedures for X MOVING ADJUST Step 2 to 4: (Procedure reviewed and descriptions added)		
	Revised	1.10	Procedures for Y MOVING ADJUST Step 2 to 4: (Procedure reviewed and descriptions added)		
4.2.15	Revised	1.10	Totally revised because of change in procedure		
4.3.1	Added	1.10	Important Box: "Set the pressure of all the clamps to Middle, ..."		
4.3.2	Revised	1.10	Totally revised because of elimination of height adjustment (elimination of use of tool)		
5.1.1	Added	1.10	Step2, 4: Because of addition of resolution "360x360"		
5.1.2	Added	1.10	Step2, 4: Because of addition of resolution "360x360"		
5.1.5	Revised	1.10	Step1: Speed designation Set value "150 mm/s" → "500 mm/s"		
	Revised	1.10	Step2: Acceleration designation Set value "0.50 G" → "2.00 G"		
	Revised	1.10	Step3: Moving amount designation Set value "500000 mm" → "Mechanical limit size"		
5.1.7	Revised	1.10	Step1: Speed designation Set value "150 mm/s" → "500 mm/s"		
	Revised	1.10	Step2: Acceleration designation Set value "0.50 G" → "2.00 G"		
	Revised	1.10	Step3: Moving amount designation Set value "500000 mm" → "Mechanical limit size"		
5.1.30	Added	1.10	Function: "Use [FUNCTION] to move the cursor..."		
6.3.3	Added	1.10	Important Box: "In reassembly, pay attention to harness treatment."		
6.4.7	Revised	1.10	Disassembly procedure: Procedure reviewed because of the elimination of the removal of X pulley and connecting shaft		
	Added	1.10	Work procedures 6: Note on reassembly		
6.4.11	Added	1.10	Tips Box: "For easy work, set clamp pressure to Low ..."		
6.5.2	Erased	1.10	Important Box: "After assembly,..."		
6.5.5	Added	1.10	Caution Box: "Be sure to turn off the main circuit breaker..."		
6.5.6	Added	1.10	Caution Box: "Be sure to turn off the main circuit breaker..."		
6.5.8	Added	1.10	Caution Box: "Be sure to turn off the main circuit breaker..."		
6.5.9	Added	1.10	Warning Box: "After turning off the sub and main power switches, ..."		
6.5.10	Erased	1.10	Caution Box: "Also, there is a possibility of electric shock because of..."		
6.5.11	Added	1.10	Caution Box: "Be sure to turn off the main circuit breaker..."		
6.5.12	Added	1.10	Caution Box: "Be sure to turn off the main circuit breaker..."		
6.5.13	Page added	1.00	"Fan Motor"		
6.6.1	Revised	1.10	"Sensor Layout" revised		
7.1.2	Revised	1.10	Rearranged according to error Nos.		
	Added	1.10	Error No. 12: "Inappropriate instruction was given concerning the printer controlling."		
	Erased	1.10	Error No. 25(FULL-SPEED): "(Full-Speed Mode connection)"		
	Added	1.10	Error No. 35-C: Cause "Since take-up is executed, ..." Remedy "Auto cutting is not performed if take-up timing is ..."		

Maintenance Manual Change Tracking

Date	2008.09.17	Manual Ver.	1.10	Remark	
Index	Status	Rev.	Changes		
7.1.2	Added	1.10	Error No. 40 to 43: "2. Make sure that the media is ..."		
	Added	1.10	Error No. 170: Remedy		
	Added	1.10	Error No. 180: Remedy		
	Added	1.10	Error No. 203: "SDRAM SIZE"		
	Added	1.10	Error No. 205: "47V HEAD VOLTAGE"		
	Added	1.10	Error No. 206: "MAIN PCB"		
	Added	1.10	Error No. 211 (HeadWARM.TEMP., BREAK, THERM): "*This error is never displayed when ..."		
7.1.3	Revised	1.10	Error No. 5: "!Do TEST DRAW" → "!CONFIRM TEST PRINT"		
	Revised	1.10	Error No. 5: "The nozzle recovery cannot be expected because the..." → "Sleep refresh or cleaning was not performed when power was..."		
	Revised	1.10	Error No. 7: "The left screen shows that..." → "This example shows that..."		
	Revised	1.10	Error No. 8: "The left screen shows that..." → "This example shows that..."		
	Revised	1.10	Error No. 21: "... has been completely." → "has been completely used up."		
	Added	1.10	Error No. 4x~4x: Newly added		
	Added	1.10	Error No. xx~xx: Newly added		
8.2.2	Erased	1.10	[PRIORITY MARGIN]		
	Added	1.10	[SETUP COPY]		
8.2.3	Added	1.10	[CR.MAINTENANCE Remove the cover]		
8.2.4	Added	1.10	[STAMP SETUP]: "*Displayed by press of [FUNCTION] ..."		
8.3.2	Added	1.10	[SETUP RESET]: "*Except when "PEN" is selected"		
	Erased	1.10	[PRIORITY]		
	Added	1.10	[SETUP COPY]		
8.3.3	Revised	1.10	[MAINTENANCE STEP SIZE] (Moved from "SETUP (CUT mode)")		
8.4.1	Added	1.10	[CONFIRM. FEED FEED] Choices: "ON/OFF" → "OFF/ 10 to 500"		
	Revised	1.10	MARGIN (Moved from "SETUP")		
8.5.1	Erased	1.10	[#ADJUST POINTER OFFSET]		
	Erased	1.10	[#CAPPING WiperPOS(Y)]		
	Added	1.10	[#LANDING UP POSITION]		

Date	2008.08.04	Manual Ver.	1.00	Remark	
Status	Index	Rev.	Changes		
Released			New issued		

Maintenance Manual Contents

1.2

1 Operating Principle

1.1 Basic Operation

- 1.1.1 Main Switch Power ON
- 1.1.2 Sub Switch Power ON
- 1.1.3 Initial Machine Operation
- 1.1.4 Detection of a Media Width
- 1.1.5 Clamp Pressure Switching
- 1.1.6 Operation for Connecting the Heads
- 1.1.7 Mark Detection
- 1.1.8 Main Switch Power OFF

1.2 Maintenance Function

- 1.2.1 CARRIAGE OUT
- 1.2.2 WIPER REPLACE
- 1.2.3 NOZZLE WASH
- 1.2.4 PUMP TUBE WASH
- 1.2.5 CR.MAINTENANCE
- 1.2.6 FILL UP INK
- 1.2.7 DISCHARGE&WASH
- 1.2.8 Maintenance Washing Liquid Filling and Discharge
- 1.2.9 Waste Ink Tank Warning
- 1.2.10 Aqua->Sol EXCHG.

1.3 Ink System

- 1.3.1 Configuration
- 1.3.2 Ink System Error Monitoring
- 1.3.3 Supply Cartridge Control and Selection
- 1.3.4 Cartridge LED Control
- 1.3.5 Supply Valve Control
- 1.3.6 Monitoring of the Amount of Remaining Ink
- 1.3.7 Use-up Cleaning
- 1.3.8 Ink Suction and Discharge Control
- 1.3.9 Initial Filling
- 1.3.10 Expiry month and extension of expiry month for ink
- 1.3.11 Initial Filling

1.4 Print & Cut

2 Electrical Parts

2.1 Block Diagram

- 2.1.1 Connection Diagram Inside the Main Body
- 2.1.2 Connection Diagram Outside the Main Body

2.2 Operating Description

- 2.2.1 Operation Explanation

2.3 Circuit Board Specifications

- 2.3.1 Power Supply PCB Assy
- 2.3.2 Main PCB Assy
- 2.3.3 PRAM PCB Assy

- 2.3.4 Regenerative Resistivity PCB Assy
- 2.3.5 Cutter Driver PCB Assy
- 2.3.6 Station PCB Assy
- 2.3.7 X-axis Motor Relay PCB Assy
- 2.3.8 Ink Slider PCB Assy
- 2.3.9 Cutter Slider PCB Assy
- 2.3.10 Head Memory PCB Assy
- 2.3.11 LED PCB Assy
- 2.3.12 Keyboard PCB Assy
- 2.3.13 Take-up PCB Assy

3 Workflow

3.1 Ink Related Parts

- 3.1.1 Replacement of the Head Unit
- 3.1.2 Replacement of the Cap Assy
- 3.1.3 Replacement of the Cartridge Assy
- 3.1.4 Replacement of the Wiper Unit

3.2 Cut Head Carriage

- 3.2.1 Replacement of the Pen Assy and LED Pointer
- 3.2.2 Replacement of the Auto Cutter Assy
- 3.2.3 Replacement of the Mark Assy

3.3 Driving Parts

- 3.3.1 Replacement of the X-axis Motor
- 3.3.2 Replacement of the Y-axis Motor
- 3.3.3 Replacement of the Y Drive Belt
- 3.3.4 Replacement of the Linear Encoder Scale
- 3.3.5 Replacement the GR Roller Assy

3.4 Electrical Parts

- 3.4.1 Replacement of the Main PCB Assy

4 Adjustment Items

4.1 Operation Matrix

- 4.1.1 Matrix of Operations and Adjustments

4.2 Adjustment Function

- 4.2.1 [HEAD ADJUST] SLANT ADJUST
- 4.2.2 [HEAD ADJUST] DROP.POS ADJUST
- 4.2.3 EDGE ADJUST
- 4.2.4 MEDIA COMP.2
- 4.2.5 CAPPING
- 4.2.6 HEAD ID
- 4.2.7 HEAD WASH
- 4.2.8 500mm SQUARE
- 4.2.9 PEN PRESSURE
- 4.2.10 LANDING
- 4.2.11 [PHOTO SENSOR] SENSOR LV.
- 4.2.12 [PHOTO SENSOR] POSITION
- 4.2.13 GR/PR POSITION
- 4.2.14 MOTOR CURRENT

Maintenance Manual Contents

- 4.2.15 PRINT/CUT POS.
- 4.2.16 SERIAL No.
- 4.2.17 DEALER No.
- 4.2.18 DEFAULT SET
- 4.2.19 REPLACE PARTS

4.3 Mechanical Adjustment

- 4.3.1 Adjusting the Location of Mark Sensor
- 4.3.2 Adjustment of the Mounting Location for the Cutter
- 4.3.3 Adjustment of the Station Height
- 4.3.4 Adjustment of the Wiper Height
- 4.3.5 Positioning of the Encoder Sensor
- 4.3.6 Centering of the Roll Holder
- 4.3.7 Positioning of the Wiper Drive Link

5 Test Items

5.1 Test Function

- 5.1.1 [CHECK PATTERN] PATTERN
- 5.1.2 [CHECK PATTERN] COLOR CHART
- 5.1.3 [CHECK PATTERN] DROP.POS CHK
- 5.1.4 ALL PATTERN
- 5.1.5 [MOTOR TEST] X SERVO MOTOR
- 5.1.6 [MOTOR TEST] Y SERVO MOTOR
- 5.1.7 [MOTOR TEST] XY SERVO MOTOR
- 5.1.8 [MOTOR TEST] WIPER MOTOR
- 5.1.9 [MOTOR TEST] PUMP MOTOR
- 5.1.10 [MOTOR TEST] TAKE-UP MOTOR
- 5.1.11 [HEATER TEST] TEMPERATURE
- 5.1.12 [HEATER TEST] SSR
- 5.1.13 ACTION TEST
- 5.1.14 SENSOR TEST
- 5.1.15 OPTION
- 5.1.16 KEYBOARD LED
- 5.1.17 KEYBOARD TEST
- 5.1.18 LCD TEST
- 5.1.19 TIMER CHECK
- 5.1.20 MEMORY CHECK
- 5.1.21 SKEW CHECK
- 5.1.22 [TEMP.CHECK] HEAD TEMP.
- 5.1.23 [TEMP.CHECK] NOZZLE TEMP.
- 5.1.24 [TEMP.CHECK] HEAT SINK TEMP.
- 5.1.25 [TEMP.CHECK] SLIDER TEMP.
- 5.1.26 LINEAR ENCODER
- 5.1.27 [INK CARTRIDGE] PACK&END SENSOR
- 5.1.28 [INK CARTRIDGE] CARTRIDGE VALVE
- 5.1.29 [INK CARTRIDGE] INK-IC CHECK
- 5.1.30 [INK CARTRIDGE] CARTRIDGE LED
- 5.1.31 [WASH CARTRIDGE] PACK&END SENSOR

- 5.1.32 [WASH CARTRIDGE] CARTRIDGE VALVE
- 5.1.33 [WASH CARTRIDGE] IC CHECK
- 5.1.34 HEAD JOINT
- 5.1.35 PINCH ROLLER
- 5.1.36 [CUT PATTERN] TEST
- 5.1.37 [CUT PATTERN] 2m
- 5.1.38 [CUT PATTERN] 10m
- 5.1.39 [CUT PATTERN] QUALITY
- 5.1.40 [CUT PATTERN] SQUARE

5.2 Other Test

- 5.2.1 Determining COM short circuit
- 5.2.2 Checking Damage of the Print Heads
- 5.2.3 Checking Damage of the Main PCB ASSY
- 5.2.4 Checking Damage of the Ink Slider PCB
- 5.2.5 Checking Conduction of HDC FFC COM Line
- 5.2.6 Checking Conduction of HDC FFC Data Line

6 Disassembly and Reassembly

6.1 Covers

- 6.1.1 Cover Layout

6.2 Ink-related Parts

- 6.2.1 Cleaning the inside of Head Unit
- 6.2.2 Removing of Head Unit
- 6.2.3 Mounting of Head Unit
- 6.2.4 Pump Motor
- 6.2.5 Pump Assy
- 6.2.6 Cap Assy
- 6.2.7 Cap Head Assy
- 6.2.8 Valve Assy
- 6.2.9 Changing Joint

6.3 Cut Head Carriage

- 6.3.1 Pen Assy and LED Pointer
- 6.3.2 Auto Cutter Assy
- 6.3.3 Mark Assy

6.4 Drive System

- 6.4.1 X-axis Motor
- 6.4.2 Y-axis Motor
- 6.4.3 Y Drive Pulley
- 6.4.4 Y Drive Belt
- 6.4.5 Linear Encoder Scale
- 6.4.6 Wiper Unit
- 6.4.7 GR Roller Assy
- 6.4.8 Take-up Motor
- 6.4.9 C Connecting Hook
- 6.4.10 P Head Connecting Hook
- 6.4.11 Clamp Assy

6.5 Electrical Parts

Maintenance Manual Contents

- 6.5.1 Power Supply PCB Assy
- 6.5.2 Main PCB Assy
- 6.5.3 PRAM PCB Assy
- 6.5.4 Head Memory PCB Assy
- 6.5.5 LED PCB Assy
- 6.5.6 Station PCB Assy
- 6.5.7 Paper Sensor
- 6.5.8 X-axis Motor Relay PCB Assy
- 6.5.9 Ink Slider PCB Assy
- 6.5.10 Cutter Slider PCB Assy
- 6.5.11 Keyboard PCB Assy
- 6.5.12 Encoder PCB Assy
- 6.5.13 Fan Motor
- 6.5.14 Take-up Motor PCB Assy
- 6.5.15 ID Contact PCB Assy
- 6.5.16 Detector Assy, I/C, Y
- 6.5.17 Replacement procedure for fuse of the Main PCB

6.6 Sensors

- 6.6.1 Sensor Layout

7 Troubleshooting

7.1 Details on Errors and Malfunctions

- 7.1.1 Concerning Errors and Malfunctions
- 7.1.2 List of Error Messages
- 7.1.3 List of Warning Messages
- 7.1.4 Trouble with No Messages

7.2 Detailed Methods of Coping with the Malfunctions

- 7.2.1 Y Drive Belt Noise
- 7.2.2 Media Attachment to the Platen
- 7.2.3 Electrical Troubleshooting
- 7.2.4 Y Drive Belt Damage
- 7.2.5 Heater temperature does not going up

7.3 Checksheet

- 7.3.1 PCB Damage Checksheet

8 Operation Flow

8.1 Basic Operation

- 8.1.1 Start
- 8.1.2 Initial Filling
- 8.1.3 Media Detection

8.2 Print Mode

- 8.2.1 LOCAL / REMOTE
- 8.2.2 SETUP
- 8.2.3 MAINTENANCE
- 8.2.4 MACHINE SETUP

8.3 Cut Mode

- 8.3.1 LOCAL / REMOTE
- 8.3.2 SETUP

8.3.3 MAINTENANCE / No. COPIES

8.4 Common Setting

8.4.1 COMMON SETUP

8.5 Service Mode

- 8.5.1 #ADJUST
- 8.5.2 #TEST
- 8.5.3 #PARAMETER

Operating Principle		
1.1 Basic Operation	1.2 Maintenance Function	1.3 Ink System
1.4 Print & Cut		

1
2
3
4
5
6
7
8

1.1.1 Main Switch Power ON

1.1

■ Indication on LCD

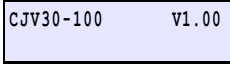
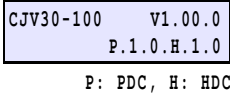
① Display at main switch power ON	② Version information display	③ Version information display (during the service mode)
		

■ Processing sequence

Step	Processing	Description	Indication on LCD
1	Initial setting of CPU and H/W		
2	Display at main switch power ON	1. [Boot] is displayed.	①
3	SD-RAM check	1. Check the read / write of SD-RAM • In the malfunction, [ERROR02 MAIN RAM] is displayed and the system goes down.	
4	F-ROM check	1. Check the hash value of F-ROM. • In the malfunction of boot system area, [ERROR01 MAIN ROM] is displayed and the system goes down. • In the malfunction of the main system area, F/W update mode starts.	
5	Voltage check	1. Check the power supply voltage on the main PCB assy. • In the malfunction, [ERROR03 POWER **V] is displayed and the system goes down.	
6	FPGA setting	1. Execute the configuration of PDC and HDC. • In the malfunction, [ERROR09 FPGA ERROR] is displayed and the system goes down. • When the fuse F13 of the main PCB assy is blown, the system shuts down, displaying [EEROR25 47V HEAD VOLTAGE].	
7	Printer configuration		
	7-1 Checks on the HDC connection	1. Check the configuration results about HDC. • HDC connection has not been completed, [ERROR09 HDC ERROR] is displayed and the system goes down.	
	7-2 Checks on the print head connection	1. Check the connection status of the print head 47V. • In the malfunction, [ERROR07 HEAD] or [ERROR07 VOLTAGE] is displayed and the system goes down.	
	7-3 Checks on the print head memory	1. Check the contents of the memory PCB assy of the print head. • In the malfunction, [ERROR200 HEAD MEMORY] is displayed and the system goes down.	
7-4 Checks on PRAM	1. Check the PRAM size. 128 MB is needed as its size. • If the size is zero, [ERROR203 SDRAM SIZE] is displayed and the system goes down.		
8	Version information display	1. Machine model name and main body firmware version are displayed. 2. "Revision" and "PDC/HDC version" are also displayed during the service mode. 3. Special key function is workable during the version information is being displayed.	② ③
9	Parameter check	1. During the initial start-up process after the upgrading of the F/W version, initialize the following parameters. • MAINTE • INKSYSTEM • INKinfo. • INKSEQUENCE • INKTYPE • SERVO • TEST • Cut FIX Parameter 2. Carry out the check sum of the parameter region. • In the malfunction, [ERROR04 F-ROM] is displayed and the system goes down.	
10	Initial operation of the printer	1. Refer to "1.1.3 Initial Machine Operation".	

1

2

3

4

5

6

7

8

1.1.2 Sub Switch Power ON

1.1

■ Indication on LCD

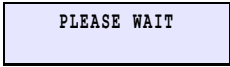
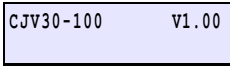
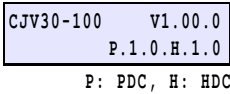
① Display at sub switch power ON	② Version information display	③ Version information display (during the service mode)
		

■ Processing sequence

Step	Processing	Description	Indication on LCD
1	Initial setting of CPU and H/W		
2	Display at sub switch power ON	1. [PLEASE WAIT] is displayed.	①
3	Voltage check	1. Check the power supply voltage on the main PCB assy. • In the malfunction, [ERROR03 POWER **V] is displayed and the system goes down.	
4	FPGA setting	1. Execute the configuration of PDC and HDC. • In the malfunction, [ERROR09 FPGA ERROR] is displayed and the system goes down. • When the fuse F13 of the main PCB assy is blown, the system shuts down, displaying [EEROR25 47V HEAD VOLTAGE].	
5	Version information display	1. Machine model name and main body firmware version are displayed. 2. "Revision" and "PDC/HDC version" are also displayed during the service mode. 3. Special key function is workable during the version information is being displayed. (Except firmware update)	② ③
6	Initial operation of the printer	1. Refer to " 1.1.3 Initial Machine Operation ".	

1

2

3

4

5

6

7

8

1.1.3 Initial Machine Operation

■ Indication on LCD

① A display at the start of the operation

PLEASE WAIT

■ Processing sequence

Step	Processing	Description	Indication on LCD
1	Detection of a station origin	1. Drive the wiper motor to detect the station origin. • When it cannot be detected, [ERROR46 WIPER] is displayed and the system goes down. • If an error occurs during the service mode, try the operation again by pressing the key [ENTER]. Pressing the key [FUNCTION] is also workable.	①
2	Detection of the Y origin.	1. Drive the Y-axis motor to detect the Y origin. • When it cannot be detected, [ERROR51 Y-ORIGIN] is displayed and the system goes down.	
3	Capping	1. Move the head carriage back to the Y origin and carry out capping.	
4	Correcting the Y-axis distance (Only when MAIN power is on)	1. Make the print head carriage go and return one time by a platen width, correct the Y-axis distance, and conduct the linear encoder test. • In the malfunction, [ERROR08 LinearENCODER] is displayed and the system goes down.	
5	Stand by of cut head	• Move the cut head to the maintenance position at the left of the unit and check the coupling of the cut head. (Refer to “1.1.6 Operation for Connecting the Heads”)	

1

2

3

4

5

6

7

8

1.1.4 Detection of a Media Width

1.1

■ Indication on LCD

① A display during the print media detection

DETECTING MEDIA NOW
PLEASE WAIT

1

■ Processing sequence

Step	Processing	Description	Indication on LCD
1	Connection of the cut head	1. Refer to "1.1.6 Operation for Connecting the Heads" .	①
2	Media right end detection	1. After moving the cut head carriage to the position of the first pinch roller, use the pinch roller detection sensor to detect the right edge of media. • When detection is impossible or the number of pinch rollers is not recognized, the display shows [ERROR50 MEDIA DETECT]. Raise the lever to cancel the error.	
3	Clamp pressure switching	1. Refer to "1.1.5 Clamp Pressure Switching" .	
4	Media left end detection	1. Move the cut head carriage left and use the pinch roller detection sensor to detect the right edge of media. • When detection is impossible or the number of pinch rollers is not recognized, the display shows [ERROR50 MEDIA DETECT]. Raise the lever to cancel the error.	
5	Stand by of head carriage	1. Move the head carriage to the standby position of the cut head.	

2

3

4



The operation for detecting a media width will be discontinued, if the clamp lever is placed on the UP position during the operation. (Only during Step 3 above)

5

6

7

8

1.1.5 Clamp Pressure Switching

■ Indication on LCD

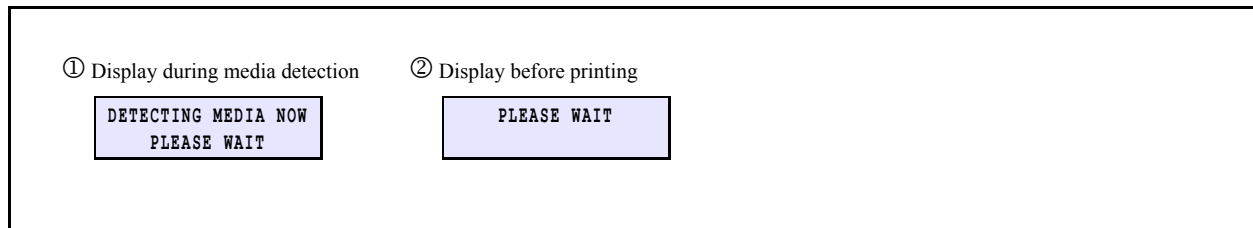

■ Processing sequence

Step	Processing	Description	Indication on LCD
1	Connection of the cut head	1. Refer to "1.1.6 Operation for Connecting the Heads" .	①
2	Clamp pressure switching	1. The head carriage moves from the right end to the left end. 2. While moving the head carriage, check the position of the pinch roller with the PR sensor. • In the malfunction, [ERROR181 PR POSITION] is displayed and the system goes down. 3. Change over the clamp pressure using the solenoid. 4. By repeating the operations described above, change over the clamp pressure of all the pinch rollers positioned from the right to the left.	②
3	Stand by of head carriage	1. Move the head carriage to the standby position of the cut head.	



Switch the clamp pressure before printing under the following conditions:

- The machine draws a stored pattern which can be selected by the user for printing or cutting.
- The clamp pressure switching command was received by output software.

1

2

3

4

5

6

7

8

1.1.6 Operation for Connecting the Heads

■ Processing sequence

□ Separation of the cut head → Connection of the print head

Step	Processing	Description
1	Separate the cut head.	<ol style="list-style-type: none"> After moving the cut head carriage to the left end and turning on the clamp solenoid, check the position of the cut head by the cut head connection sensor. <ul style="list-style-type: none"> In the malfunction, [ERROR170 CUTTER LOCK] is displayed. After checking the position, turn off the clamp solenoid and lock up the cut head. Move the head connecting unit to the right and separate the cut head.
2	Connection of the print head	<ol style="list-style-type: none"> Move the head connecting unit to the right end. After checking a Y origin, connect the print head to the cut head. <ul style="list-style-type: none"> In the malfunction, [ERROR170 CUTTER LOCK] is displayed. Turn on the print head solenoid and unlock the print head. Detect a Y origin again and cap the print head. Turn off the print head solenoid and lock up the print head. <ul style="list-style-type: none"> When starting to plot, turn on the print head solenoid and unlock the print head, then move the print head.

□ Separation of the print head → Connection of the cut head

Step	Processing	Description
1	Separate the print head.	<ol style="list-style-type: none"> After turning on the print head solenoid, move the print head carriage and check a Y origin. <ul style="list-style-type: none"> In the malfunction, [ERROR170 PRINT HEAD LOCK] is displayed and the system goes down. After checking the Y origin, move the print head back to the capping position and carry out capping. Turn off the print head solenoid and lock up the print head. Move the head connecting unit to the left and separate the print head.
2	Connection of the cut head	<ol style="list-style-type: none"> Move the head connecting unit to the left end. Connect the cut head to the head connecting unit and after turning on the clamp solenoid, check the position of the cut head by the cut head connection sensor. <ul style="list-style-type: none"> In the malfunction, [ERROR170 PRINT HEAD LOCK] is displayed and the system goes down. Detect a Y origin again and cap the print head. Move the head connecting unit back to the standby position of the cut head carriage and turn off the clamp solenoid, then lock up the cut head. <ul style="list-style-type: none"> When starting the cutting operation, turn on the clamp solenoid and unlock the cut head, and then move the cut head.

1

2

3

4

5

6

7

8

1.1.7 Mark Detection

■ Mark shape

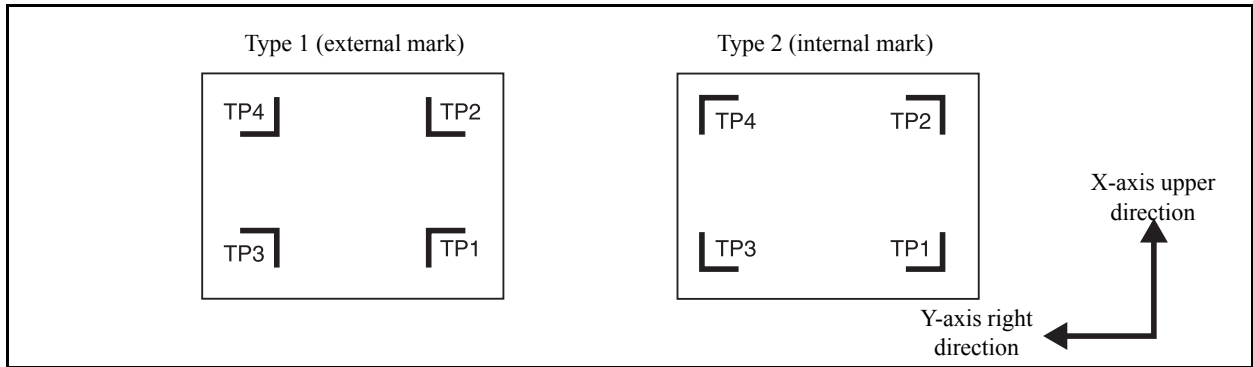

- The procedure described below is for 4-point mark detection that is performed after media detection.
- At 4-point mark detection, the registration marks will be detected in the following order: TP1 (Vertical → Horizontal) → TP3 (Vertical → Horizontal) → TP4 (Vertical → Horizontal) → TP2 (Vertical → Horizontal)

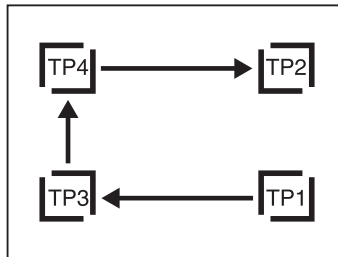

■ Processing sequence ?1/3?

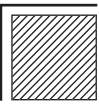
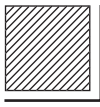
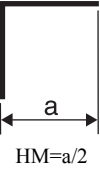
Step	Processing	Description
1	The plotter enters mark detection mode	1. If mark detection is set to any other than OFF in the [CUT MODE] -> [SETUP] -> [MARK DETECT] procedure, the light pointer turns on after media detection and the system moves to the mark detection mode.
2	Move the light spot of the light pointer into the mark detection start area	1. By operating JOG keys, move the light spot of the light pointer into the mark detection start area and then press the [ENTER] key. <div style="display: flex; justify-content: space-around; align-items: center;"> <div style="text-align: center;">  <p>Type 1 (external mark) Mark detection start area</p> </div> <div style="text-align: center;">  <p>Type 2 (internal mark) Mark detection start area</p> </div> </div>
3	Photo sensor moves to the light spot position	1. The mark sensor moves to the light spot position by the cut head carriage and media feed operation.
4	Searching for vertical line of mark (TP1)	1. The head moves in the Y-axis left direction (for type 1) or Y-axis right direction (for type 2) until the mark sensor turns on and stops. 2. The head moves in the Y-axis left direction (for type 1) or Y-axis right direction (for type 2) by the distance of HM. 3. The head moves in the Y-axis right direction (for type 1) or Y-axis left direction (for type 2) until the mark sensor turns on and stops. 4. The plotter determines the center of the vertical line based on the positions of "1" and "3". 5. Finally the head moves in the Y-axis right direction (for type 1) or Y-axis left direction (for type 2) by the distance of HM and terminates. <div style="text-align: right; margin-top: 10px;">  </div>

1

2

3

4

5

6

7

8

1.1.7 Mark Detection

■ Processing sequence ?2/3?

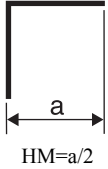
Step	Processing	Description
5	Searching for horizontal line of mark (TP1)	<ol style="list-style-type: none"> The head moves in the X-axis upper direction (for type 1) or X-axis lower direction (for type 2) until the mark sensor turns on and stops. The head moves in the X-axis upper direction (for type 1) or X-axis lower direction (for type 2) by the distance of HM. The head moves in the X-axis lower direction (for type 1) or X-axis upper direction (for type 2) until the mark sensor turns on and stops. The plotter determines the center of the horizontal line based on the positions of "1" and "3". Finally the head moves in the X-axis upper direction by the distance of HM and terminates. 
6	Searching for vertical line of mark (TP3)	<ol style="list-style-type: none"> When the distances between the marks are known by the procedure for scale compensation with the setting value "BEFORE", the head moves in the X-axis upper direction by "Distance between marks -Length which is twice the mark size". The head moves in the Y-axis left direction until the mark sensor turns on and stops. The head moves in the Y-axis left direction by the distance of HM. The head moves in the Y-axis right direction until the mark sensor turns on and stops. The plotter determines the center of the vertical line based on the positions of "2" and "4". Finally the head moves in the Y-axis left direction (for type 1) or Y-axis right direction (for type 2) by the distance of HM and terminates. <ul style="list-style-type: none"> If the vertical line is not detected even after a search of the maximum printing range, [ERROR36-C MARK DETECT] appears.
7	Searching for horizontal line of mark (TP3)	<ol style="list-style-type: none"> The head moves in the X-axis upper direction (for type 1) or X-axis lower direction (for type 2) until the mark sensor turns on and stops. The head moves in the X-axis upper direction (for type 1) or X-axis lower direction (for type 2) by the distance of HM. The head moves in the X-axis lower direction (for type 1) or X-axis upper direction (for type 2) until the mark sensor turns on and stops. The plotter determines the center of the vertical line based on the positions of "1" and "3". Finally the head moves upward by HM of the horizontal line of TP3 and to the left (for type 1) or to the right (for type 2) by HM of the vertical line. <ul style="list-style-type: none"> If the horizontal line cannot be detected, the plotter determines that the vertical line detected above is not part of a mark and repeats the procedure from Step 6.
8	Searching for horizontal line of mark (TP4)	<ol style="list-style-type: none"> When the distances between the marks are known by the procedure for scale compensation with the setting value "BEFORE", the head moves in the X-axis upper direction by "Distance between marks -Length which is twice the mark size". The head moves in the X-axis upper direction until the mark sensor turns on and stops. The head moves in the X-axis upper direction by the distance of HM. The head moves in the X-axis lower direction until the mark sensor turns on and stops. The plotter determines the center of the horizontal line based on the positions of "2" and "4". Finally the head moves in the X-axis upper direction (for type 1) or X-axis lower direction (for type 2) by the distance of HM and terminates. <ul style="list-style-type: none"> If the horizontal line is not found even after a search of a range up to 5 m, [ERROR36-C MARK DETECT] appears. If "no media" is detected at the tail end detection position during a search for a horizontal line, the plotter performs the tail end detection of the media first and then continues horizontal line detection.
9	Searching for vertical line of mark (TP4)	<ol style="list-style-type: none"> The head moves in the Y-axis right direction (for type 1) or Y-axis left direction (for type 2) until the mark sensor turns on and stops. The head moves in the Y-axis right direction (for type 1) or Y-axis left direction (for type 2) by the distance of HM. The head moves in the Y-axis left direction (for type 1) or Y-axis right direction (for type 2) until the mark sensor turns on and stops. The plotter determines the center of the horizontal line based on the positions of "1" and "3". Finally the head moves in the Y-axis right direction by the distance of HM and terminates.

1

2

3

4

5

6

7

8

1.1.7 Mark Detection

■ Processing sequence ?3/3?

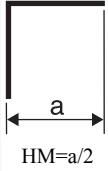
Step	Processing	Description
10	Searching for vertical line of mark (TP2)	<ol style="list-style-type: none"> When the distances between the marks are known by the procedure for scale compensation with the setting value "BEFORE", the head moves in the Y-axis right direction by "Distance between marks -Length which is twice the mark size". The head moves in the Y-axis right direction until the mark sensor turns on and stops. The head moves in the Y-axis right direction by the distance of HM. The head moves in the Y-axis left direction until the mark sensor turns on and stops. The plotter determines the center of the horizontal line based on the positions of "2" and "4". Finally the head moves in the Y-axis right direction (for type 1) or Y-axis left direction (for type 2) by the distance of HM and terminates. <ul style="list-style-type: none"> If the vertical line is not detected even after a search of the maximum printing range, [ERROR36-C MARK DETECT] appears. 
11	Searching for horizontal line of mark (TP2)	<ol style="list-style-type: none"> The head moves in the X-axis lower direction (for type 1) or X-axis upper direction (for type 2) until the mark sensor turns on and stops. The head moves in the X-axis lower direction (for type 1) or X-axis upper direction (for type 2) by the distance of HM. The head moves in the X-axis upper direction (for type 1) or X-axis lower direction (for type 2) until the mark sensor turns on and stops. The plotter determines the center of the vertical line based on the positions of "1" and "3". At the end of mark detection, the pen tip moves to the corner of TP1, which is the center of the vertical line and the center of the horizontal line of TP1. <ul style="list-style-type: none"> If the horizontal line cannot be detected, the plotter determines that the vertical line detected above is not part of a mark and repeats the procedure from Step 10.
12	The plotter completes registration mark detection	<ol style="list-style-type: none"> The corner of TP1 works as the origin from here on.

1

2

3

4

5

6

7

8

1.1.8 Main Switch Power OFF

■ Indication on LCD

① Display at sub switch power OFF

PLEASE WAIT
POWER OFF

1

■ Processing sequence

□ Processing during sub-power OFF

Step	Processing	Description	Indication on LCD
1	Hardware resources OFF	1. Turn off the heater, dry fan, exhaust fan, and vacuum fan. 2. Turn off the output of the COM waveform.	①
2	Stand by head connecting unit	1. Move the head connecting unit to the print head for connecting.	
3	Turning off solenoids	1. Turn off the Print head solenoid, clamp solenoid, and cartridge valve solenoid.	
4	Saving parameters	1. Save parameter values of system parameter, running parameter, etc. 2. Update head ID and Print head memory.	
5	Setting up sleeve start-up time	1. Set the start-up time of operations executed during sub-power OFF such as sleeve refresh, pump tube cleaning, and cleaning.	
6	Motor OFF	1. Turn off servo and drive motor power.	
7	Sub-power LED blinking	1. Indicates sub-power off by sub-power LED blinking.	
8	Power OFF		

2

3

4

5

□ Processing during main-power OFF

Step	Processing	Description
1	Saving parameters	1. Save the running parameter values.

6

 In service mode, the buzzer sounds when the parameter values have been stored successfully.

7



- Turn off sub-power to implement the sleeve operation for the prevention of the clogged ink during power OFF.
- When turning off main power, turn off sub-power first and then main power.

8

Operating Principle		
1.1 Basic Operation	1.2 Maintenance Function	1.3 Ink System
1.4 Print & Cut		

1
2
3
4
5
6
7
8

1.2.1 CARRIAGE OUT

■ Indication on LCD

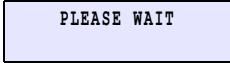
① Display during maintenance	② Display during initial operation
	

1

■ Processing sequence

Step	Processing	Description	Indication on LCD
1	Start	1. Taking the cap off 2. After moving the print head carriage to the maintenance location, the wiper moves to the wiping location and the servo motor is turned off.	
2	Maintenance	1. The unit does not operate during maintenance. 2. Waiting for the end of maintenance is displayed. It is terminated by [ENTER].	①
3	End	1. After the wiper moves to its origin, move the print head carriage, then perform the initial machine operation. See " 1.1.3 Initial Machine Operation ".	②

2

3

 Out of "Service mode", a warning beep sounds at an interval of 30 seconds during carriage out operation to prevent the nozzle surface and the inside of the cap from getting dry.

4

5

6

7

8

1.2.2 WIPER REPLACE

1.0

■ Indication on LCD

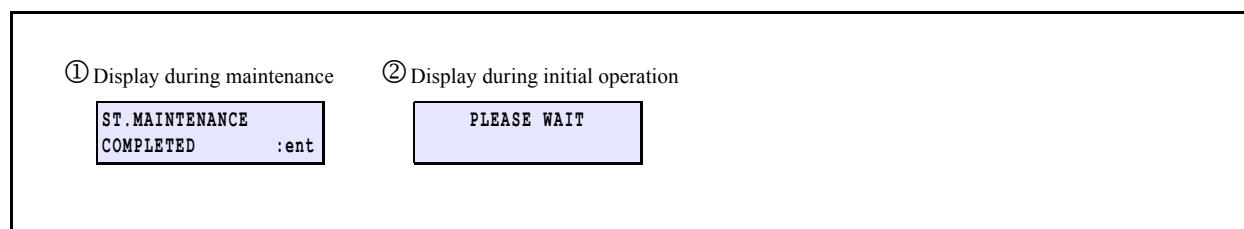

1

■ Processing sequence

Step	Processing	Description	Indication on LCD
1	Start	1. Taking the cap off 2. After moving the print head carriage to the maintenance location, the wiper moves to the wiping location and the servo motor is turned off.	
2	Maintenance	1. The unit does not operate during maintenance. 2. Waiting for the end of maintenance is displayed. It is terminated by [ENTER].	①
3	End	1. After the wiper moves to its origin, move the print head carriage, then perform the initial machine operation. See " 1.1.3 Initial Machine Operation ".	②

2

3



- After completion of this operation, clear the executed wiping count, one of the running parameters.
- Out of "Service mode", a warning beep sounds at an interval of 30 seconds during carriage out operation to prevent the nozzle surface and the inside of the cap from getting dry.

4

5

6

7

8

1.2.3 NOZZLE WASH

1.1

■ Indication on LCD

① Display during maintenance	② Display during maintenance	③ Display during maintenance	④ Display during initial operation
WIPER CLEANING COMPLETED (NEXT) :ent	Fill the liquid. COMPLETED (NEXT) :ent	ST.MAINTENANCE LEAVING TIME : 1min	PLEASE WAIT

■ Processing sequence

Step	Processing	Description	Indication on LCD
1	Start	<ol style="list-style-type: none"> Taking the cap off. After moving the print head carriage to the maintenance location, the wiper moves to the wiping location and the servo motor is turned off. Locking the pump tube. 	
2	Maintenance (Wiper)	<ol style="list-style-type: none"> The unit does not operate during maintenance. Waiting for the end of maintenance is displayed. (Waiting for [ENTER] input) 	①
3	Maintenance (Nozzle wash)	<ol style="list-style-type: none"> Turning the wiper off Lock the pump tube and display the message. (Waiting for [ENTER] input) Input the waiting time. (Waiting for [ENTER] input) Setting value: 1 - 99 min. (unit: 1 min.) After moving the print head carriage and performing “Initial machine operation (1.1.3)”, wait for the set time to elapse. Press [FUNCTION], and the maintenance washing liquid will be injected into the cap. 	② ③
4	End	<ol style="list-style-type: none"> Executing cleaning End 	



Out of “Service mode”, a warning beep sounds at an interval of 30 seconds during carriage out operation to prevent the nozzle surface and the inside of the cap from getting dry.

1

2

3

4

5

6

7

8

1.2.4 PUMP TUBE WASH

■ Indication on LCD

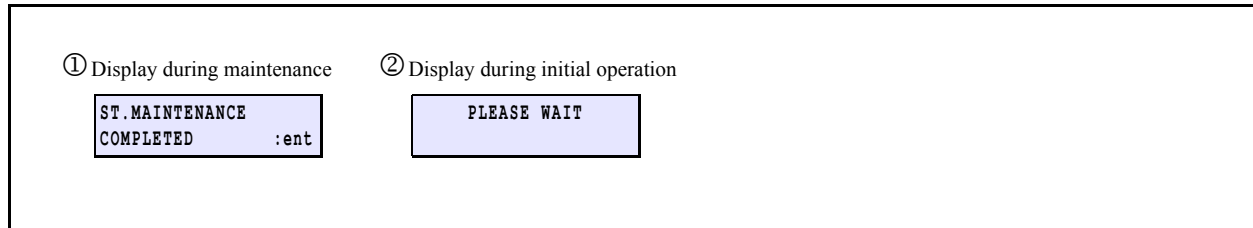

■ Processing sequence

Step	Processing	Description	Indication on LCD
1	Start	<ol style="list-style-type: none"> Taking the cap off After moving the print head carriage to the maintenance location, the wiper moves to the wiping location and the servo motor is turned off. 	
2	Maintenance (Pump tube wash)	<ol style="list-style-type: none"> Repeat the following operations until depressing [ENTER] key. <ul style="list-style-type: none"> Locking the pump tube No action for 10 seconds Dry suction for 5 seconds Maintenance washing liquid is poured into the cap by depressing the [FUNCTION] key. 	①
3	End	<ol style="list-style-type: none"> Dry suction for 20 seconds Initial Machine Operation (1.1.3) 	②



Out of “Service mode”, a warning beep sounds at an interval of 30 seconds during carriage out operation to prevent the nozzle surface and the inside of the cap from getting dry.

1

2

3

4

5

6

7

8

1.2.5 CR.MAINTENANCE

■ Indication on LCD

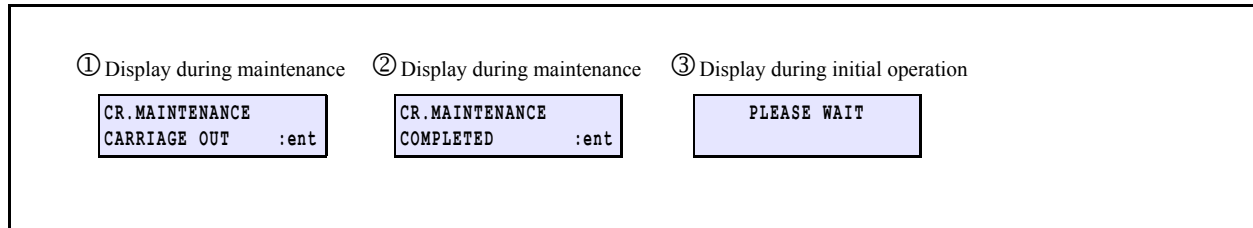

■ Processing sequence

Step	Processing	Description	Indication on LCD
1	Start	1. Taking the cap off 2. After moving the print head carriage to the maintenance location, the wiper moves to the wiping location and the servo motor is turned off.	
2	Maintenance	1. The unit does not operate during maintenance. 2. Waiting for the end of maintenance is displayed. It is terminated by [ENTER].	①
3	End	1. After moving the print head carriage, perform initial machine operation. See " 1.1.3 Initial Machine Operation ".	②



Out of "Service mode", a warning beep sounds at an interval of 30 seconds during carriage out operation to prevent the nozzle surface and the inside of the cap from getting dry.

1

2

3

4

5

6

7

8

1.2.6 FILL UP INK

■ Indication on LCD

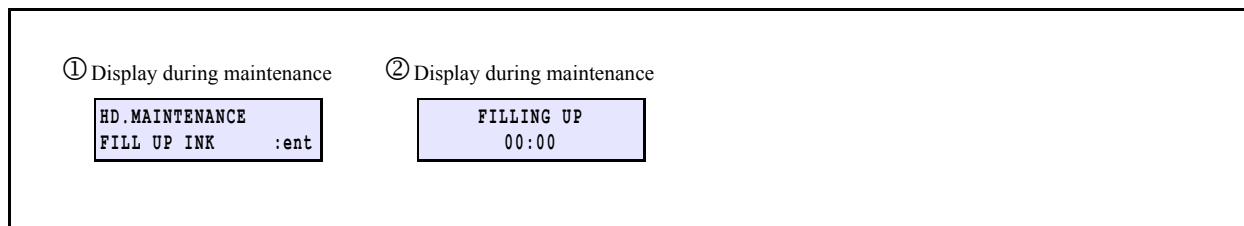

■ Processing sequence

Step	Processing	Description	Indication on LCD
1	Start	1. When a waste ink tank warning occurs, the warning message is displayed. • For details, see " 1.2.9 Waste Ink Tank Warning ".	
2	Filling	1. Opening the cartridge valve and starting the ink suction motor. 2. The filling operation is to be discontinued if a warning about the ink cartridge is detected. 3. The cartridge with less amount of remaining ink is used first. (Only for the 4-color ink set)	① ②
3	End	1. Stopping the pump motor	

1

2

3

4

5

6

7

8

1.2.7 DISCHARGE&WASH

1.0

■ Indication on LCD

① Display during maintenance Remove:InkCartridges MMCCYYKK	② Display during maintenance * DISCHARGE * 00:00	③ Display during maintenance Set:WashingCartridges 12345678	④ Display during maintenance * ABSORPTION * 00:00
⑤ Display during maintenance Remove:Cartridges 12345678	⑥ Display during maintenance SELECT: END< >Re-WASH	⑦ Display during maintenance Maint.WashLiquid END < >DISCHARGE	⑧ Display during maintenance Remove:Maint.Wash

■ Processing sequence

Step	Processing	Description	Indication on LCD
1	Ink discharging	<ol style="list-style-type: none"> Remove the ink cartridges (from all the slots). (*Monitored with cartridge sensors) Open the cartridge valve and drive the ink suction pump motor to discharge ink. When a waste ink tank warning occurs, the warning message is displayed. • For details, see "1.2.9 Waste Ink Tank Warning". 	① ②
2	Cleaning	<ol style="list-style-type: none"> Insert washing liquid cartridges (into all the slots). (*Monitored with cartridge sensors) Cleaning the inside of the tubes • Opening the cartridge valve and starting the ink suction pump motor When a waste ink tank warning occurs, the warning message is displayed. (For details, see "1.2.9 Waste Ink Tank Warning".) Performing head vibration operation (starting the Y-axis motor) 	③ ④
3	Discharging of washing liquid	<ol style="list-style-type: none"> Remove the washing liquid cartridges (from all the slots). (*Monitored with cartridge sensors) Open the cartridge valve and drive the ink suction pump motor to discharge washing liquid. When a waste ink tank warning occurs, the warning message is displayed. • For details, see "1.2.9 Waste Ink Tank Warning". 	⑤ ②
4	Repeating	<ol style="list-style-type: none"> Executing 2 to 3 again. 	
5	Operation selection	<ol style="list-style-type: none"> Select processing as below. [▶] Re-WASH : No. 3 → 4 are executed again [◀] END : to next step. 	⑥
6	Whether to discharge maintenance washing liquid	<ol style="list-style-type: none"> Select processing as below. [▶] DISCHARGE : to next step. [◀] END : to Step 9 (End) 	⑦
7	Maintenance washing liquid discharge	<ol style="list-style-type: none"> Discharge maintenance washing liquid. • For details, see "1.2.8 Maintenance Washing Liquid Filling and Discharge". 	⑧
8	End	<ol style="list-style-type: none"> (Once the ink discharge operation of this cleaning function is executed, the heads will be empty of ink.) 	



The washing liquid cartridge does not incorporate an IC chip.
Therefore, IC chip read error is recognized to be normal.

1

2

3

4

5

6

7

8

1.2.8 Maintenance Washing Liquid Filling and Discharge

1.0

■ Indication on LCD

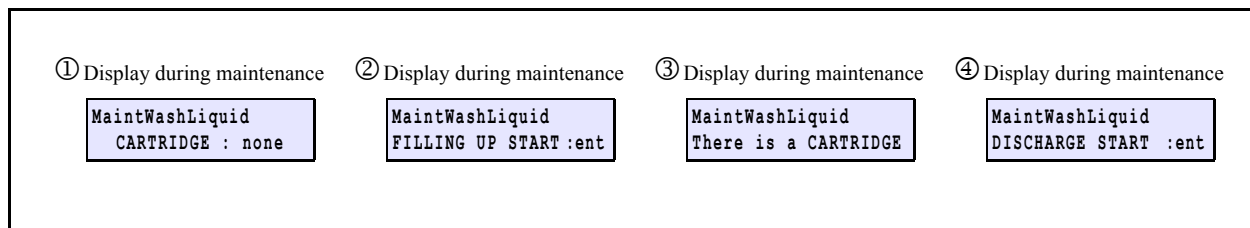

■ Washing liquid filling sequence

Step	Processing	Description	Indication on LCD
1	Start	1. Insert washing liquid cartridges. <ul style="list-style-type: none"> Filling will not be executed if a warning about the washing liquid cartridge is displayed. (Monitored with washing liquid cartridge sensors) When a waste ink tank warning occurs, the warning message is displayed. (For details, see "1.2.9 Waste Ink Tank Warning".) 	①
2	Filling	1. Run the pump. 2. Opening the cartridge valve. (until washing liquid fills the wiper cleaning valve) 3. Close the cartridge valve. 4. Stopping the pump	②

■ Washing liquid discharge sequence

Step	Processing	Description	Indication on LCD
1	Start	1. Remove the washing liquid cartridges from the printer. <ul style="list-style-type: none"> When a waste ink tank warning occurs, the warning message is displayed. (For details, see "1.2.9 Waste Ink Tank Warning".) 	③
2	Discharge	1. Run the pump. 2. Opening the cartridge valve. (until washing liquid fills the wiper cleaning valve) 3. Close the cartridge valve. 4. Stopping the pump.	④

1.2.9 Waste Ink Tank Warning

■ Indication on LCD

① Warning display in local mode ② Display when near full is reached ③ Display when full is reached

<LOCAL. 1> [#01]
!WASTE TANK

Confirm a waste tank
Continue< >Exchange

Confirm a waste tank
Exchange :ent

■ Outline

The counter in the machine monitors the amount of discharged ink. Depending on the status, the message is displayed on LCD to urge you to replace the waste ink tank before operations involving suction (cleaning, filling, and discharge).

■ Explanation of situation

No.	Status	Description	Indication on LCD
1	[!WASTE TANK] is displayed locally.	<ol style="list-style-type: none"> Is displayed when the counter in the machine reaches full or more. When it is displayed, sleep and routine operations (REFRESH, PUMP TUBE WASH, CLEANING) are not performed. When you cancel the warning message, be sure to replace the waste ink tank before executing [MAINTENANCE] -> [InkTankReplace]. The operation in "3" clears the counter in the machine. 	①
2	Waste ink tank reaches near full.	<ol style="list-style-type: none"> If you select "Continue", the present operation is continued. The warning message is displayed again during the next suction operation. If "REPLACE" is selected, the present operation is continued. The counter value in the firmware is cleared. 	②
3	Waste ink tank reaches full.	<ol style="list-style-type: none"> Replace the waste ink tank or dispose of ink. The present operation is continued by depressing [ENTER] key. The counter value the machine is cleared. 	③



- If you select "REPLACE" in the operation as above when the waste ink tank is near full or full, be sure to replace the waste ink tank or dispose of ink. If you continue to use the waste ink tank without replacing it, the waste ink may overflow before the confirmation message is displayed.
- The waste ink discharged when [NOZZLE WASH], [PUMP TUBE WASH] or [COSTODY WASH] of [ST.MAINTENANCE] is performed is not cumulatively counted in this unit. Before and after these operations, be sure to check the status of the waste ink tank.

1

2

3

4

5

6

7

8

1.2.10 Aqua->Sol EXCHG.

■ Functional Overview

The function is to replace aqueous pigmented ink with solvent ink on same machine.
Maintenance Open Mode is selectable while filling up aqueous pigmented ink
Menu :> FUNCTION>Maintenance>Aqua->Sol EXCHG.

■ Processing Sequence

“DISCHARGE & WASH” + “Initial Filling” performs when starting-up
Solvent ink becomes selectable with “Initial Filling” in this function.



- If normal “Discharge & Wash” is performed while using aqueous pigmented ink, solvent ink is not selectable when initial ink filling.

■ Requisite for this function

Head cleaning cartridge (cleaning cartridge for aqueous pigmented ink) SPC-188S
Solvent ink filling cartridge SPC-0475

1

2

3

4

5

6

7

8

Operating Principle

1.1 Basic Operation	1.2 Maintenance Function	1.3 Ink System
1.4 Print & Cut		

1

2

3

4

5

6

7

8

1.3.1 Configuration

■ Ink Supply Path Diagrammatic Illustration



When TPC is used, put Bl on C, and put Lbl on Lc below.

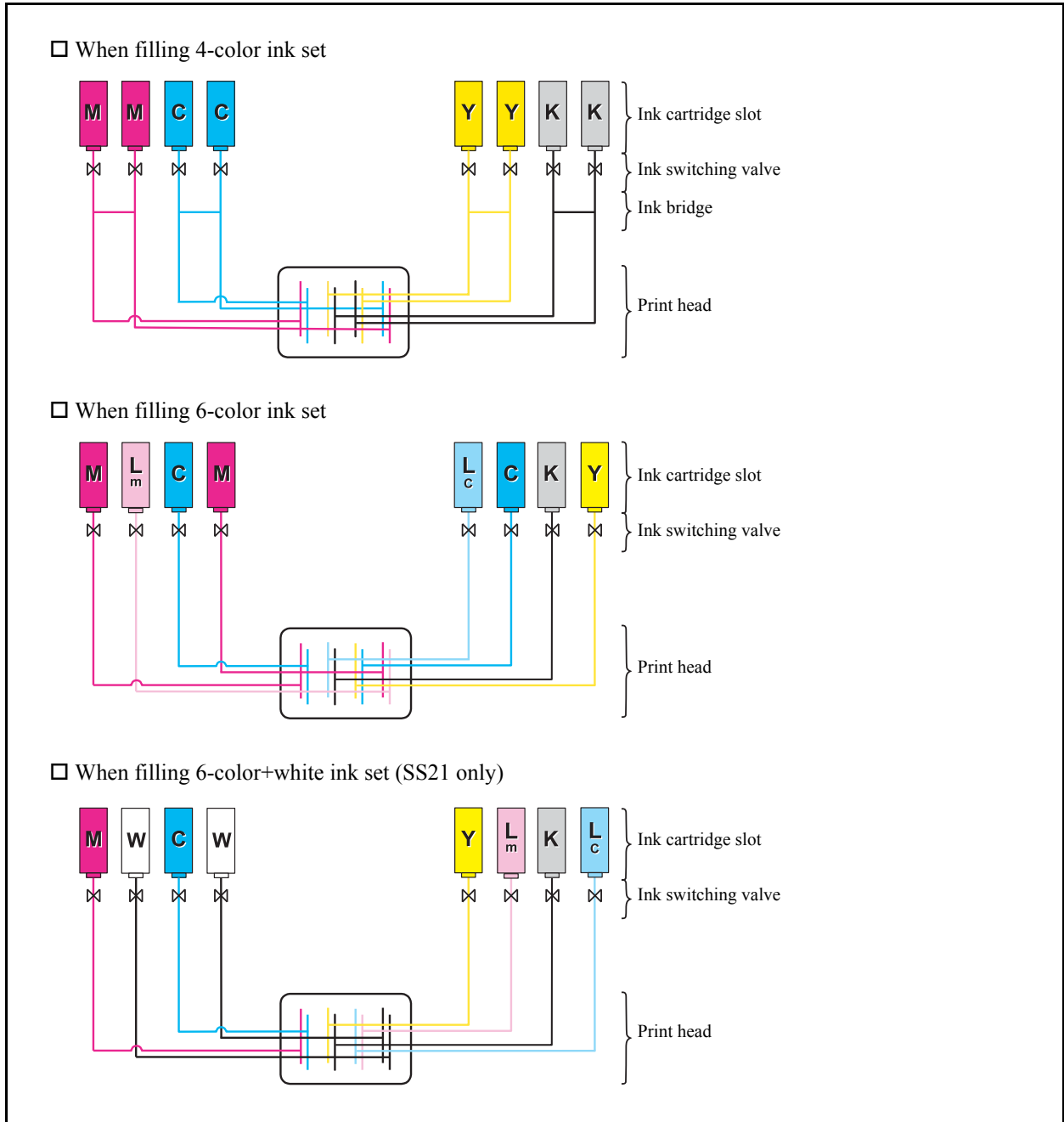

1

2

3

4

5

6

7

8

1.3.1 Configuration

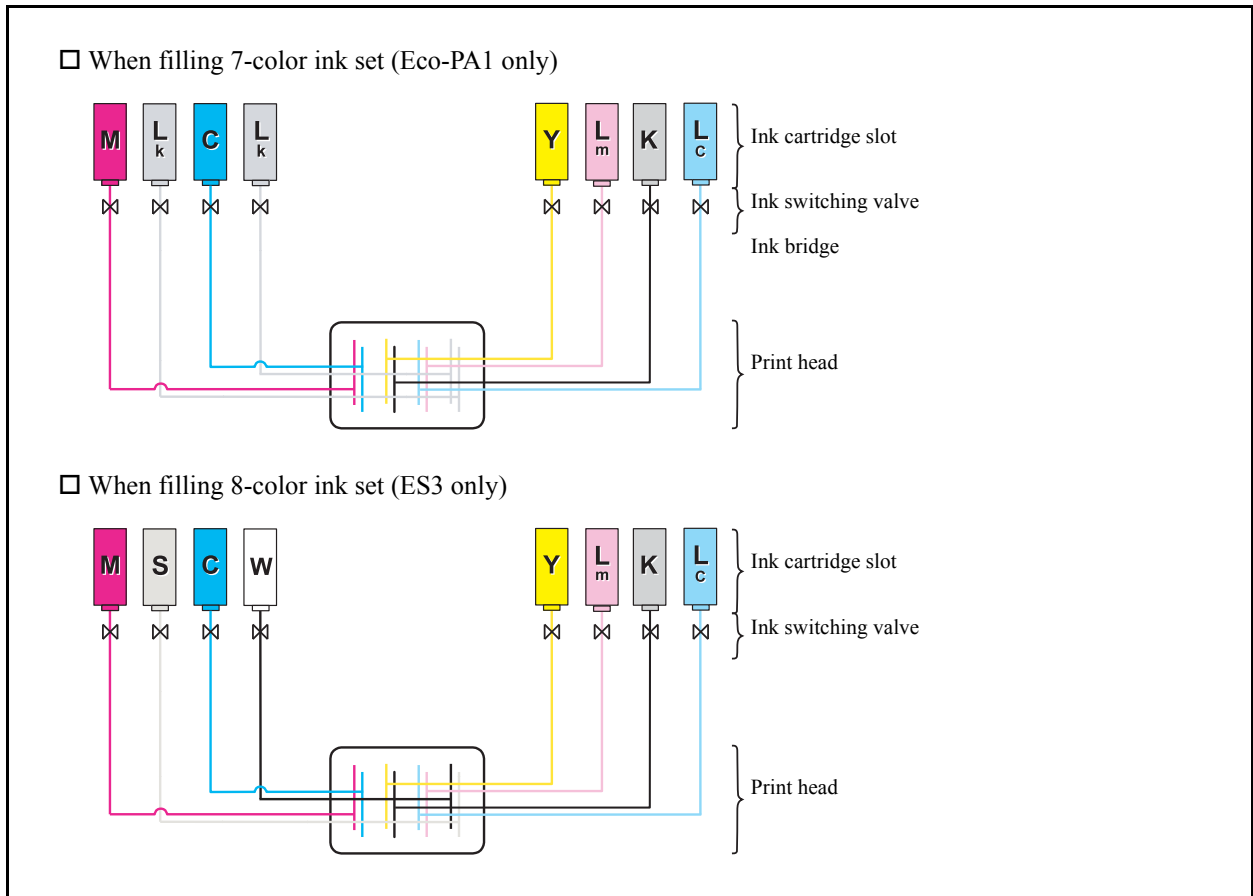

■ Flow of the ink supply control

No.	Item	Description
1	Monitoring of cartridge error	Monitors a cartridge error when ink is supplied. For details, see "1.3.2 Ink System Error Monitoring".
2	Control and selection of supply cartridge	Checks the status of the ink cartridge and selects the cartridge (for the 4-color ink set). For details, see "1.3.3 Supply Cartridge Control and Selection"
3	Updating of cartridge LED status	Updates the LED status depending on the status of ink supply and errors. For details, see "1.3.4 Cartridge LED Control"
4	Open/close supply valves	Open/close the ink supply valves depending on the control and selection of the ink supply cartridge. For details, see "1.3.5 Supply Valve Control"

1
2
3
4
5
6
7
8

1.3.1 Configuration

■ Ink system configuration

No.	Item	Description
1	When filling 4-color ink set	<ul style="list-style-type: none"> ◆ Two paths of the same color are linked shortly after the cartridge valves. ◆ Normally the valve of 1 cartridge per color is opened by toggle switching, supplying ink to a 2-nozzle row. ◆ Thereafter, the cartridge on the side with the open valve is referred to as the control cartridge, while the other is referred to as the sub cartridge. ◆ Longer consecutive drawing time than conventional products and replacement of cartridges during the drawing are allowed by toggle switching of 2 cartridges for 1 supply path.
2	When filling any ink set other than 4-color ink set (6-color ink set, 6-color + white ink set, 7-color ink set, 8-color ink set)	<ul style="list-style-type: none"> ◆ 1 cartridge is connected to a 1-nozzle row. No toggle is switched and all cartridges are control cartridges. ◆ Since 1 cartridge is assigned to 1 path, it cannot be replaced during printing.
3	Ink supply system	<ul style="list-style-type: none"> ◆ The ink filling method of CJV30 uses a suction system with a roller pump, and a pressure damper with a self-sealing valve. ◆ Ink is supplied with a siphon during printing. ◆ The damper sealing valve opens to supply ink when the discharge pressure drops, and the sealing valve closes when the damper ink chamber is filled. ◆ The sealing valve reduces the ink path pressure that reaches the head meniscus during the carriage motion.
4	Replacing ink cartridge	<ul style="list-style-type: none"> ◆ The warning message is displayed if the cartridge is not installed even after a lapse of 10 minutes to prevent the supply system from getting dry.
5	Ink supply valve	<ul style="list-style-type: none"> ◆ For each cartridge, a supply valve is provided to supply ink by opening it. ◆ The supply valve is normally closed and is opened only when ink supply is required. ◆ Ink supply is executed during discharge operation (for printing or flushing) and suction operation (for cleaning or filling). The supply valve for any cartridge that has developed an error does not open, thus does not allow ink supply.
6	Ink cartridge LED	<ul style="list-style-type: none"> ◆ For each cartridge, two LEDs (green: control LED; red: error LED) are used to allow the user to visually check the cartridge state. ◆ Since all 8 cartridges are control cartridges except when 4-color ink set is used, the green LED is on for cartridges where there is no error.
7	Ink use-up cleaning (Only for the 4-color ink set)	<ul style="list-style-type: none"> ◆ For cleaning, the printer switches the supply valve to the cartridge that has displayed [INK NEAR END] or [INK END] to use the cartridge with the smaller amount of residual ink first. For details, see "1.3.7 Use-up Cleaning".

1

2

3

4

5

6

7

8

1.3.2 Ink System Error Monitoring

■ Monitoring of cartridge error

No.	Item	Description
1	Cartridge error check	<ul style="list-style-type: none"> ◆ A cartridge error is periodically checked (every 30 ms). ◆ Select the supply cartridge in taking into account the error status and the amount of remaining ink.
2	LED control when an error occurs	<ul style="list-style-type: none"> ◆ The green LED lights up to indicate that the supply cartridge is now being controlled. ◆ The red LED lights up or blinks to indicate that the cartridge must or should be replaced.
3	Supply valve control when an error occurs	<ul style="list-style-type: none"> ◆ The valve for the cartridge where the green LED is lit opens when the instruction to open the valve is issued. ◆ When an error occurs in a supply cartridge while the valve is open (during printing or cleaning), the valve switches to the other cartridge which can supply ink, if any, to continue printer operation. If a supply cartridge is removed, printing or cleaning will be stopped and the printer will return to LOCAL mode.



Since all 8 cartridges are control cartridges except when the 4-color ink set is used, printing or cleaning is stopped when an error occurs and the printer returns to LOCAL mode.

■ Monitoring of ink system error

The ink system are checked for any error periodically (every 30 ms), and printer operation is limited according to the error, if detected. The table below shows the possible errors and the limitations on printer operation.

Priority	Ink system error	Execution status when an error occurs*2				Description of the error
		CL/ filling	Printing	Head cleaning	Pump cleaning	
1	Initial filling is not executed	X	X	X	X	Initial filling has not been executed.
2	INK END error	X	X	○	○	Errors occurred in both cartridges and printing & suction operation can not be executed.
3	INK NEAR END error	X	○	○	○	<ul style="list-style-type: none"> ◆ Waste ink tank is almost full. ◆ Printer returns to LOCAL mode every completion of printing one file.
4	Waste Ink Tank	X	X	X	X	When the amount of waste ink counted by the waste tank firmware increases to a certain amount after it displays near full.
5	NO CARTRIDGE	X	X	X	X	No cartridge has been installed.
6	Ink IC *1	X	X	X	X	<ul style="list-style-type: none"> ◆ An error related to the cartridge IC has occurred. ◆ Ink supply is impossible.
7	INK REMAIN ZERO (Only for the 4-color ink set)	X	X	X	○	<ul style="list-style-type: none"> ◆ Ink in the cartridge is used up. ◆ Ink supply is impossible.
8	Cartridge ink end	X	X	○	○	<ul style="list-style-type: none"> ◆ Ink in the cartridge has been used to the end level, with a predetermined small amount of ink remaining. ◆ Ink supply is impossible. (CL can be used)
9	Cartridge near end	○	○	○	○	<ul style="list-style-type: none"> ◆ The Near End sensor has detected the nearly ink end status. ◆ The cartridge can be used for printing or cleaning.
10	Expiration: 1 MONTH	○	○	○	○	One month has passed since the expiration date of the ink.
11	Notification of nozzle cleaning execution	○	○	○	○	Prompts the user to follow the nozzle cleaning procedure.
12	!Replace a WIPER	○	○	○	○	The wiper operation count has exceeded the number which requires the replacement the wiper.
13	!WashLiquidCart.NONE	○	○	○	X	No washing liquid cartridge has been installed.
14	!WRONG WASH CART.	○	○	○	X	Trouble with the ink washing liquid cartridge
15	!Wash Liquid END	○	○	○	X	The washing liquid cartridge is empty.
16	Expiration	○	○	○	○	Ink expiration has been reached.
17	!WASTE TANK	X	○	X	X	Waste ink tank is almost full. (counted by firmware)
18	REINSERT CARTRIDGE	X	X	X	X	INK NEAR END has been detected by mistake and the machine prompts you to reset ink cartridge.

*1 Ink IC: NON-ORIGINAL INK, WRONG INK IC, Kind of INK, Color of INK, WRONG CARTRIDGE, Expiration: 2MONTH

*2 ○: Executable X: Inexecutable

1.3.2 Ink System Error Monitoring

■ Errors related to the amount of remaining ink

- Calculate the number of ink shots by printing and flushing or the amount of ink sucked by cleaning and filling, and then the amount of consumed ink by subtraction of remaining ink.
- When the amount of remaining ink is updated, it is written into the ink IC chip.
- A cartridge error is issued according to the amount of remaining ink.

No.	Item	Description	
		Error detect timing	Limitations after error detection
1	Cartridge near end	The amount of remaining ink is detected on the near end detect PCB assy. The specified value of each cartridge is as follows: ◆ 220 cc cartridge: 20 cc ◆ 440 cc cartridge: 40 cc	Initial filling is not allowed, but printing and cleaning are allowed.
2	Cartridge ink end	Displayed when use of a certain amount of ink is detected after the near end detection.	Neither printing nor initial filling is allowed, but cleaning is allowed.
3	INK REMAIN ZERO (Only for the 4-color ink set)	◆ Displayed when the amount of remaining ink is detected to be 0 cc after the ink end detection. ◆ This error may be displayed only after completion of ink use-up cleaning.	None of printing, initial filling and cleaning is allowed.
4	WRONG CARTRIDGE	Occurs when the amount of consumed ink exceeds nearly double (220 cc cartridge: 400 cc, 440 cartridge: 800 cc or more) the ink cartridge capacity but the ink end is not displayed yet.	None of printing, initial filling and cleaning is allowed.

1

2

3

4

5

6

7

8

1.3.3 Supply Cartridge Control and Selection

■ Supply cartridge control

No.	Item	Description
1	For the 4-color ink set	<ul style="list-style-type: none"> ◆ The printer uses two ink cartridges for 1 supply system (1 nozzle row) and can mount 8 cartridges in total. ◆ 1 supply cartridge is assigned to 1 supply system. The cartridge with less amount of remaining ink is used first by toggle switching. ◆ Switching between cartridges for ink supply occurs under any of the following conditions: <ul style="list-style-type: none"> • “INK END” during printing • “INK NEAR END” during filling • Ink IC warning • When the cartridge is removed • When executing Ink use-up cleaning
2	Except for the 4-color ink set (filling 6-color, 6-color + white, 7-color, 8-color ink set)	<ul style="list-style-type: none"> ◆ Since there is 1 ink cartridge per supply system, all 8 cartridges are supply cartridges.

■ Cartridge status indicated by LEDs

LED	Status	Explanation
Green	Lit	Supply cartridge
Red	Blink	INK END, INK NEAR END, Expiration:1MONTH
	Lit	<ul style="list-style-type: none"> ◆ NO CARTRIDGE ◆ WRONG INK IC Errors related to PIC, namely, NON-ORIGINAL INK, WRONG INK IC, Kind of INK, Color of INK, WRONG CARTRIDGE and Expiration:2MONTH ◆ INK REMAIN ZERO A cartridge having no remaining ink after execution of ink use-up cleaning (only in 4-color use).

■ Selection and determination of the supply cartridge for the 4-color ink set

□ supply cartridge switching selection timing

- At power-on
- When an error occurs in the currently selected cartridge
- When a cartridge with higher priority than the currently selected cartridge is inserted
- Switching is not executed during printing or cleaning but executed when the printer has returned to LOCAL mode.

1.3.3 Supply Cartridge Control and Selection

1.2

- When there is more than one effective cartridge for 1-ink supply path

Priority	Cartridge status
1	Expired cartridge
2	The cartridge having the smaller amount of remaining ink is selected.
3	If there is no distinction at "2", the cartridge closer to the expiration date is selected.
4	If there is no distinction at "2" and "3", the cartridge in the smaller slot number is selected.*1

*1 with FUNCTION>MACHINE SETUP>CART. PRIORITY, the priority order of "2" and "3" is replaced.

Priority	Cartridge status (Before V1.30)
1	The cartridge having the smaller amount of remaining ink is selected.
2	If there is no distinction at "1", the cartridge closer to the expiration date is selected.
3	If there is no distinction at "1" and "2", the cartridge in the smaller slot number is selected.

■ The priority order of supply when using MBIS1 (FW Ver.2.00)

- When using MBIS1 in all slots

● Refer to the table above "When there is more than one effective cartridge for 1-ink supply path".

- When using MBIS1 and the ink cartridge as mixed loading through supply path of the same color

● Use MBIS1 cartridge by priority.

If MBIS1 is expired, the ink cartridge is switched to use by priority.

Also, the cartridge using by priority can be switched temporarily with the operation below.

1. Press [ENTER] key on Local or Remote.
2. Press [REMOTE] key. Select or change with the JOG key.

SS21INK	MMCCYYKK
REMAIN	99999999

[REMOTE]
->

BULK/CART SELECT
- B B B<

Supplying cartridge is displayed.
“-” Not mixed, “B” MBIS, “C” ink cartridge



- In the case of no mixed loading, the function above cannot be used.
- The setting is restored by taking out the ink cartridge selected or turning off the power. (Supplies from MBIS side.)

1

2

3

4

5

6

7

8

1.3.3 Supply Cartridge Control and Selection

When one cartridge for 1-supply path has an error

- The printer selects the other cartridge if available.
- The conditions for cartridge selection vary depending on the error type and ink supply timing. Ink supply is executed during discharge operation (for printing, flushing, etc.) or during suction operation (for cleaning or filling). The table below shows the conditions for cartridge selection.

No.	Cartridge status	Discharge operation* ²	Suction operation* ²
1	Normal cartridge	○	○
2	Cartridge near end	○	△
3	Cartridge ink end	X	△
4	Residual quantity 0 cartridge	X	X
5	No cartridge	X	X
6	Ink IC* ¹	X	X

*1 Ink IC: NON-ORIGINAL INK, WRONG INK IC, Kind of INK, Color of INK, WRONG CARTRIDGE, Expiration:2MONTH

*2 ○: Available for ink supply. X: Not available for ink supply
△: Available for ink supply when the other cartridge is normal

Availability of ink supply

Cartridge 1 \ Cartridge 2	Normal cartridge	Cartridge near end	Cartridge ink end	Residual quantity 0 cartridge	No cartridge Ink IC * ¹
	Normal cartridge	○	○	○	○
Cartridge near end	○	△	△	△	△
Cartridge ink end	○	△	X	X	X
Residual quantity 0 cartridge	○	△	X	X	X
No cartridge	○	△	X	X	X
Ink IC* ¹	○	△	X	X	X

*1 Ink IC: NON-ORIGINAL INK, WRONG INK IC, Kind of INK, Color of INK, WRONG CARTRIDGE, Expiration:2MONTH

○: Both discharge and suction are allowed. X: Neither discharge nor suction is allowed (Ink end error).
△: Discharge is allowed but suction not allowed (Ink near end error).

Conditions for changing the supply cartridge

Control cartridge \ Sub cartridge	Normal cartridge	Cartridge near end	Cartridge ink end	Residual quantity 0 cartridge	No cartridge Ink IC * ¹
	Normal cartridge	△	○	-	-
Cartridge near end	-	△	-	-	-
Cartridge ink end	○	○	-	-	-
Residual quantity 0 cartridge	○	○	-	-	-
No cartridge	○	○	-	-	-
Ink IC* ¹	○	○	-	-	-

*1 Ink IC: NON-ORIGINAL INK, WRONG INK IC, Kind of INK, Color of INK, WRONG CARTRIDGE, Expiration:2MONTH

○: Switched - : Not switched
△: Switched according to priority. (No operation by the condition as above during cleaning)

1

2

3

4

5

6

7

8

1.3.4 Cartridge LED Control

■ Condition of each cartridge LED indicated by its lighting and blinking

The two LEDs light up or blink to indicate the condition of the cartridge and help the user determine the time for replacing the cartridge.

LED		Cartridge status
Control LED (Green)	Not lit	No cartridge has been selected as the supply cartridge
	Blinking	–
	Lit	<ul style="list-style-type: none"> ◆ A cartridge has been selected as the supply cartridge (All cartridge LEDs are Lit for any other than the 4-color ink set except when an error occurs.) ◆ Ink use-up cleaning is now being performed For details, see "1.3.7 Use-up Cleaning".
Error LED (Red)	Not lit	The cartridge is normal
	Blinking	An error has occurred (Blinking signifies that one of the following errors has occurred) <ul style="list-style-type: none"> ◆ Cartridge near end ◆ Cartridge ink end ◆ One month has passed since the expiration date of the ink
	Lit	An error has occurred (Lighting signifies that one of the following errors has occurred) <ul style="list-style-type: none"> ◆ Residual quantity 0 cartridge ◆ No cartridge ◆ Ink IC*¹ ◆ REINSERT CARTRIDGE

*1 Ink IC: NON-ORIGINAL INK, WRONG INK IC, Kind of INK, Color of INK, WRONG CARTRIDGE, Expiration:2MONTH

■ LED operation pattern

Event	For the 4-color ink set				Except for the 4-color ink set	
	Cartridge 1		Cartridge 2		Cartridge 1	
	Control LED	Error LED	Control LED	Error LED	Control LED	Error LED
Online supply start ◆ Both cartridges free from problems ◆ Cartridge 1 is the control cartridge.	Lit	–	–	–	Lit	–
Cartridge 1 ◆ Cartridge near end	Lit	Blink	–	–	Lit	Blink
Cartridge 1 ◆ Cartridge ink end ◆ Cartridge 2 is the control cartridge.	–	Blink	Lit	–	–	Blink
Cartridge 2 ◆ Cartridge near end	–	Blink	Lit	Blink		
Cartridge 1 ◆ Removed for replacement	–	Lit	Lit	Blink	–	Lit
Cartridge 1 ◆ A normal cartridge has been set	–	–	Lit	Blink	Lit	–
Cartridge 2 ◆ Cartridge ink end ◆ Cartridge 1 is the control cartridge.	Lit	–	–	Blink		
Online printing has been completed ◆ All valves closed	Lit	–	–	Blink	Lit	–

1.3.5 Supply Valve Control

■ Cartridge switching operation

Event		For the 4-color ink set		Except for the 4-color ink set
		Cartridge 1 valve	Cartridge 2 valve	Cartridge 1 valve
1	Online supply start ♦ Both cartridges free from problems ♦ Cartridge 1 is the control cartridge.	OPEN	CLOSE	OPEN
2	Cartridge 1 ♦ Cartridge near end	No change	No change	No change
3	Cartridge 1 ♦ Cartridge ink end ♦ Cartridge 2 is the control cartridge.	CLOSE	OPEN	CLOSE
4	Cartridge 2 ♦ Cartridge near end	No change	No change	
5	Cartridge 1 ♦ Removed for replacement	No change	No change	CLOSE
6	Cartridge 1 ♦ A normal cartridge has been set	No change	No change	OPEN
7	Cartridge 2 ♦ Cartridge ink end ♦ Cartridge 1 is the control cartridge.	OPEN	CLOSE	
8	Online printing has been completed ♦ All valves closed	CLOSE	CLOSE	CLOSE

■ Timing to open/close the supply valve

The supply valves are usually closed and opened only when ink supply is required.

Timing to open/close the supply valves is shown below:

Timing to open/close the supply valves		Instruction to open/close the supply valve
Flushing	Before execution	OPEN
	After execution	CLOSE
Cleaning or filling	Before execution	OPEN
	After execution	CLOSE
Head wash	Before execution	OPEN
	After execution	CLOSE
Before printing operation		OPEN
Before capping operation		CLOSE
When changing the supply cartridge during ink supply		OPEN/CLOSE
At the occurrence of an system error		CLOSE
At power-off		CLOSE

1.3.6 Monitoring of the Amount of Remaining Ink

■ Outline

- The amount of remaining cartridge ink is calculated in such a way that the amount of ink consumed for the following operations is calculated by subtraction of remaining ink.
 - Number of ink shots by printing and flushing
 - Amount of ink suction by cleaning and filling
- When the amount of remaining ink is updated, it is written into the ink IC chip.
- A cartridge error is issued according to the amount of remaining ink.

■ Calculation of the amount of consumed ink

- Ink discharging during printing and flushing
 - The amount of ink consumed by ink discharging is calculated by counting the number of ink shots.
 - CJV30 counts ink shots for each row of nozzles and performs calculation by taking account of dot sizes (small, middle and large). Therefore, there will be a smaller error between the measured value and the calculated value, as compared with the conventional models.
- Ink suction during cleaning and filling

The table below shows the amount of ink consumed for various operations. (For the 4-color ink set)

Operation		Ink consumption through one supply path [cc]			
		CJV30-60	CJV30-100 / TPC-1000	CJV30-130	CJV30-160
SOFT cleaning		0.40			
NORMAL cleaning		1.20			
HARD cleaning		6.20			
Maintenance filling		14.00			
Initial filling (No replacement)	Main suction	31.30	36.10	42.80	42.80
	Cobble filling	4.70			
Initial filling (At replacement)	Main suction	31.30	36.10	42.80	42.80
	Cobble filling	4.70			

1

2

3

4

5

6

7

8

1.3.6 Monitoring of the Amount of Remaining Ink

1.2

(For the 6-color / 6-color + W / 8-color ink set)

Operation		Ink consumption through one supply path [cc]			
		CJV30-60	CJV30-100 / TPC-1000	CJV30-130	CJV30-160
SOFT cleaning		0.20			
NORMAL cleaning		0.60			
HARD cleaning		3.10			
Maintenance filling		7.00			
Initial filling (No replacement)	Main suction	17.70	20.40	24.60	24.60
Initial filling (At replacement)	Main suction	17.70	20.40	24.60	24.60
WHITE MAINT. Lv.1		3.70			
WHITE MAINT. Lv.2	White	6.70			
	Color	3.70			
WHITE MAINT. Lv.3	White	12.20	12.70	15.70	15.70
	Color	3.70			
Spot color maintenance	Color for performing maintenance	10.50	11.20	13.40	13.40
	Other colors	3.10			

■ Updating of the amount of remaining ink

The amount of remaining ink will be updated and written onto the ink IC chip at the timing shown below.

No.	Timing for updating	Execution conditions
1	At pre-capping operation	<ul style="list-style-type: none"> ◆ Ink has been used for printing or flushing. ◆ At capping chiefly after completion of printing.
2	At completion of cleaning and filling operation	<ul style="list-style-type: none"> ◆ Ink has been used for cleaning and filling. ◆ The amount of ink remaining in the cartridge used for the suction will be updated.
3	When any of the following events has occurred during printing, cleaning or filling: <ul style="list-style-type: none"> ◆ Cover OPEN ◆ Lever UP ◆ Media end 	<ul style="list-style-type: none"> ◆ Updated by the amount of ink consumed before the occurrence of any of the events shown at left.
4	When any of the following errors has occurred during printing: <ul style="list-style-type: none"> ◆ Cartridge near end ◆ Cartridge ink end ◆ Cartridge error 	<ul style="list-style-type: none"> ◆ Updated just after occurrence of the error, not waiting for writing at the capping pre-operation. ◆ Updated before replacing the cartridge during printing.

1

2

3

4

5

6

7

8

■ **As for Use-up cleaning**

- This function is available only for the 4-color ink set.
- This function is intended to use the remaining ink in the cartridge where “cartridge near end” or “cartridge ink end” occurs during cleaning with higher priority and prevent the ink of the normal cartridge from being consumed.
- When one cartridge is a normal one at the start of cleaning, ink is sucked from the cartridge with residual ink first and then switching to the normal cartridge takes place to continue cleaning.
- When the residual ink is used up (software counter), “INK REMAIN ZERO” error is displayed, disabling the cartridge.



Ink use-up cleaning control is only effective in NORMAL cleaning mode. It cannot be executed in any other cleaning mode or at initial filling.

1

2

3

4

5

6

7

8

1.3.8 Ink Suction and Discharge Control

■ Outline of Control

1. The ink suction and discharge mechanism is driven by roller pumps (ink suction pumps).
2. The amount of ink discharged to the waste ink tank is counted by the firmware, and warnings are issued depending on the level. They are displayed in sequences involving ink suction and discharge, or locally.
3. The printer is equipped with an automatic cleaning mechanism (pump tube cleaning) to prevent ink solidification in the waste ink tube connecting the inside of the cap to the waste ink tank.
4. Cleaning is performed by drawing washing liquid from the washing liquid cartridge to the cap using the siphon principle. It is performed periodically when power is turned on/off.

■ System configuration

The system configuration of the ink suction and discharge mechanism is as shown below.

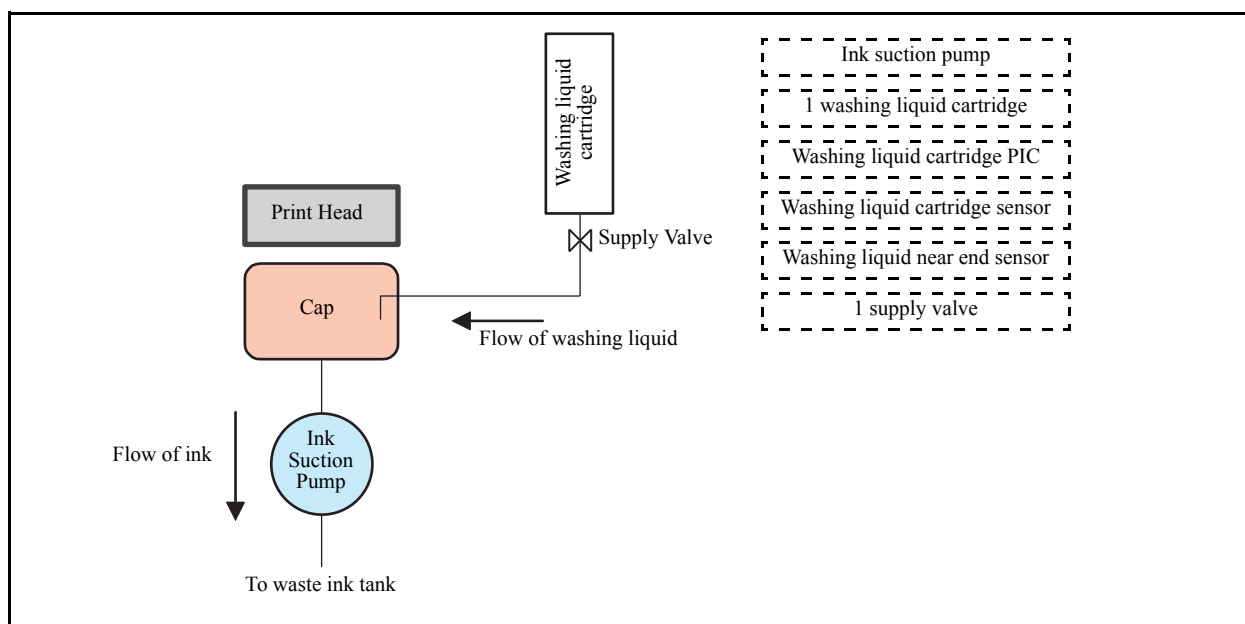

■ Outline flow



In initial filling for the 4-color ink set, to eject air completely from the ink paths, the suction is divided into 2 stages, (①) filling up to the coupler, and (②) filling up to the nozzle. Each uses the sub cartridge and control cartridge.

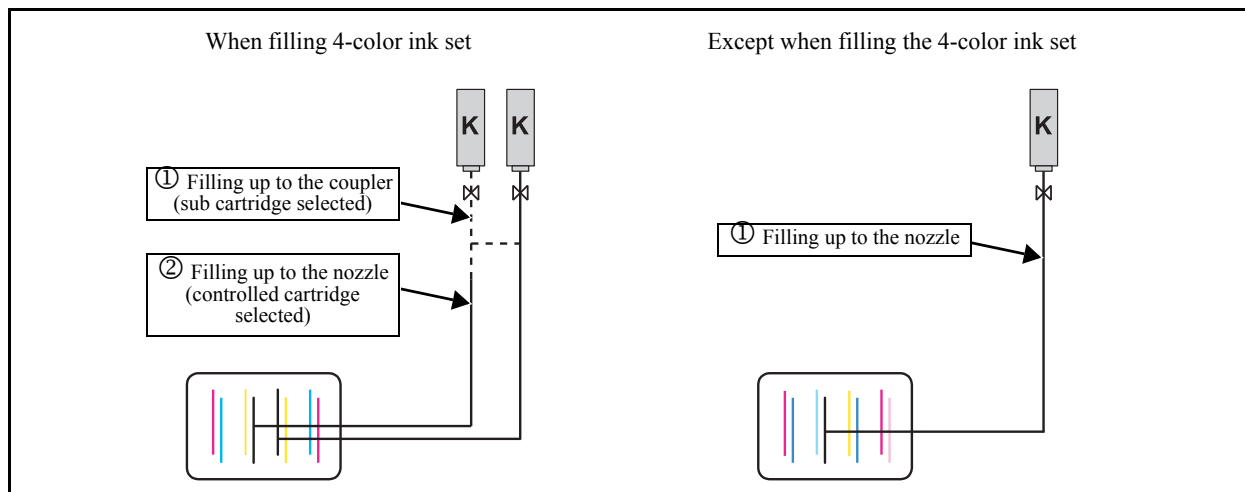

1

2

3

4

5

6

7

8

1.3.9 Initial Filling

■ Operation sequence for initial filling

The sequence of initial ink filling is shown below:

No.	Item	Description
1	Selection of ink type (ink type)	Select a set value shown below. Setting value: ES3 Sol, SS21 Sol
2	Selection of number of colors (ink set)	Select a set value shown below. Setting value: 4-Color (MMCCYYKK), 6-Color (MmCMcCKY), 6+W Color (MWCWYmKc) (Only when SS21 is selected) 8-Color (MSCWYmKc) (Only when ES3 is selected)
3	Preparing to fill the pre-fill up solution	Discharge the transportation liquid remaining in the ink path.
4	Filling of pre-fill up solution	Insert a pre-fill up solution cartridge in all slots to be sucked (all 8 cartridges). ♦ Suction will not be performed if a warning about any pre-fill up solution cartridge is displayed. (The pre-fill up solution cartridges do not incorporate an IC chip. Therefore, IC chip read error is recognized to be normal.) ♦ When a waste ink tank warning occurs, the warning message is displayed.
5	Discharging of the pre-fill up solution	Discharge the pre-fill up solution.
6	Ink filling	Insert the ink cartridges into all the slots and start ink filling. When filling the 4-color ink set: 1. Fill ink up to the coupler. Within the same supply system, open the carriage valves in the order of even columns → odd columns, and fill the ink up to the coupler. 2. Fill ink up to the damper (head) Except when filling the 4-color ink set: 1. Open all of the cartridge valves and fill the ink up to the damper (head). • Filling will not be executed if a warning about the ink cartridge is displayed. • When a waste ink tank warning occurs, the warning message is displayed. • If a cartridge warning is displayed after completion of filling ink up to the coupler and before completion of filling ink up to the damper (head), switching between the cartridges will take place and filling will be continued. (Only for filling the 4-color ink set) Filling will be discontinued if one supply system becomes unable to supply ink.
7	Washing liquid filling	♦ Fill the pump tube cleaning system with the dedicated washing liquid. ♦ Make sure that the washing liquid cartridge has been inserted into the slot, and then start supplying the solution. ♦ Filling will not be executed if a warning about the washing liquid cartridge is displayed. ♦ When a waste ink tank warning occurs, the warning message is displayed.



If filling any other than the 4-color ink set when this unit is installed, you have to change the coupler before initial filling.

1

2

3

4

5

6

7

8

1.3.10 Expiry month and extension of expiry month for ink

1.0

■ About ink expiry month

It can be useable by month after next month of the ink expiry date described on the ink cartridge.

Here is the handle of expired

Example: If expiry month of your ink cartridge is February 2009.

February	March	April	May or later	September or later
Printable continuously		Not Printable Continuously *1	Not printable (Unusable)	Not Printable(Unusable) / Not extend expiry month
		Red LED Blink	Led LED lights	Led LED lights
	Expiration	Expiration: 1M	Expiration: 2M	COMPLETELY EXPIRED

*1.the machine returns to local mode every completion of printing one file.

■ Extension of ink expiry date (F/W Ver2.00)

The ink, which can be normally unusable two months after normal expiry month, can be extended for 6 months from the expired month.

If the expired cartridge sets up, and also power is on with cartridge setting, the operation to confirm the extension runs.

① EXTEND EXPIRE DATE?
YES < :> NO ◇
Alternately
Displayed NOT RECOMENDED!!
YES < > NO

② EXPIRE DATE EXTENDED
PRESS [ENT] It is possible to press only [ENTER] key.

If the extended ink cartridge sets up, and also power is on with cartridge setting, the operation to confirm the extension runs.

It is possible to press only [ENTER] key. Get users to acknowledge the possibility of deteriorating image quality since the extended ink cartridge is in use.

EXPIRED INK IN USE
PRESS [ENT] ◇
Alternately
Displayed NOT RECOMENDED!!
PRESS [ENT]

LED blinks in green if the extended cartridge is in use.



- The setting is not changeable with the cartridge has been extended once
- Deteriorating image quality may be appeared such as color change and banding if the cartridge is extended. Get users to understand this.
- The ink, which is more than 2 months has been elapsed since the cartridge was expired, can not be useable for initial ink filling even though it can be extended.

1

2

3

4

5

6

7

8

1.3.11 Initial Filling

■ Replacing procedure

Current ink -> Target ink	Shipping status ES3 8-color	SS21 4-color -> ES3 8-color	SS21 6-color -> ES3 8-color	SS21 6- color+White -> ES3 8-color	ES3 4-color -> ES3 8-color	ES3 6-color -> ES3 8-color
Initial status	Shipping status	SS21 4-color	SS21 6-color	SS21 6- color+White	ES3 4-color	ES3 6-color
	↓	↓	↓	↓	↓	↓
Step1 Version check of F/W and RLP	Check that JV33 F/W = Ver.4.60, CJV30 F/W = Ver.2.50 and RLP5 = Ver.2.2. If they are not as above, perform version upgrade.					
	↓	↓	↓	↓	↓	↓
Step2 Head wash- ing	Turning ON the front power sup- ply -> discharge of solvent filling liquid (SPC- 0475)	Select "YES" to "Do you change an ink set?" from "#ADJUST"-> "HEAD WASH".	Select "NO" to "Do you change an ink set?" from "#ADJUST"-> "HEAD WASH".	Select "NO" to "Do you change an ink set?" from "#ADJUST"-> "HEAD WASH".	Select "YES" to "Do you change an ink set?" from "#ADJUST"-> "HEAD WASH".	Select "NO" to "Do you change an ink set?" from "#ADJUST"-> "HEAD WASH".
		↓	↓	↓	↓	↓
		MS washing liquid set -> washing				
Step3 Replacing UIS coupling	↓	Replacing 4-color with 8-color	↓	↓	Replacing 4-color with 8-color	↓
	↓	↓	↓	↓	↓	↓
Step4 Replacing damper	↓	Replace 7th damper only (white is filled). Do not replace other than that.	Replace 7th damper only (white is filled). Do not replace other than that.	Replace 7th and 8th dampers (white was filled). Do not replace other than those.	Replace 7th damper only (white is filled). Do not replace other than that.	Replace 7th damper only (white is filled). Do not replace other than that.
	↓	↓	↓	↓	↓	↓
Step 5 Ink Filling	↓	Select ES3 8-color for "Choose an ink type".				
	↓	↓	↓	↓	↓	↓
	ES3 8-Color -> Filling					
	↓	↓	↓	↓	↓	↓
Step 6 Nozzle Check	Nozzle check					
	↓	↓	↓	↓	↓	↓
	Good			If it is No Good, perform refilling until it becomes Good.		
	↓	↓	↓	↓	↓	↓
Step 7 Adjustment	Adjust					

1

2

3

4

5

6

7

8

1.3.11 Initial Filling

Current ink -> Target ink	ES3 8-color -> SS21 4-color	ES3 8-color -> SS21 6-color	ES3 8-color -> SS21 6- color+White	ES3 8-color -> ES3 4-color	ES3 8-color -> ES3 6-color
Initial status	ES3 6-color+ White+Silver	ES3 8-color	ES3 8-color	ES3 8-color	ES3 8-color
Step1 Version check of F/W and RLP	↓	↓	↓	↓	↓
Step2 Head wash- ing	Select "YES" to "Do you change an ink set?" from "#ADJUST"-> "HEAD WASH".	Select "NO" to "Do you change an ink set?" from "#ADJUST"-> "HEAD WASH".	Select "NO" to "Do you change an ink set?" from "#ADJUST"-> "HEAD WASH".	Select "YES" to "Do you change an ink set?" from "#ADJUST"-> "HEAD WASH".	Select "NO" to "Do you change an ink set?" from "#ADJUST"-> "HEAD WASH".
	↓	↓	↓	↓	↓
	MS washing liquid set -> washing				
	↓	↓	↓	↓	↓
Step3 Replacing UIS coupling	Replacing 8-color with 4-color	↓	↓	Replacing 8-color with 4-color	↓
	↓	↓	↓	↓	↓
Step4 Replacing damper	Replace 7th and 8th dampers (white and silver were filled). Do not replace other than those.				
	↓	↓	↓	↓	↓
Step 5 Ink Filling	Select ES3 8-color for "Choose an ink type".				
	↓	↓	↓	↓	↓
	SS21 4-color -> Filling	SS21 6-color -> Filling	SS21 6- color+White -> Filling	ES3 4-color -> Filling	ES3 6-color -> Filling
	↓	↓	↓	↓	↓
Step 6 Nozzle Check	Nozzle check				
	↓	↓	↓	↓	↓
	If it is No Good, perform refilling until it becomes Good.				
	↓	↓	↓	↓	↓
Step 7 Adjustment	Adjust				

1
2
3
4
5
6
7
8

Operating Principle

1

**1.1
Basic Operation**

**1.2
Maintenance Function**

**1.3
Ink System**

**1.4
Print & Cut**

2

3

4

5

6

7

8

1

2

3

4

5

6

7

8

Electrical Parts		
2.1 Block Diagram	2.2 Operating Description	2.3 Circuit Board Specifications

2.1.1 Connection Diagram Inside the Main Body

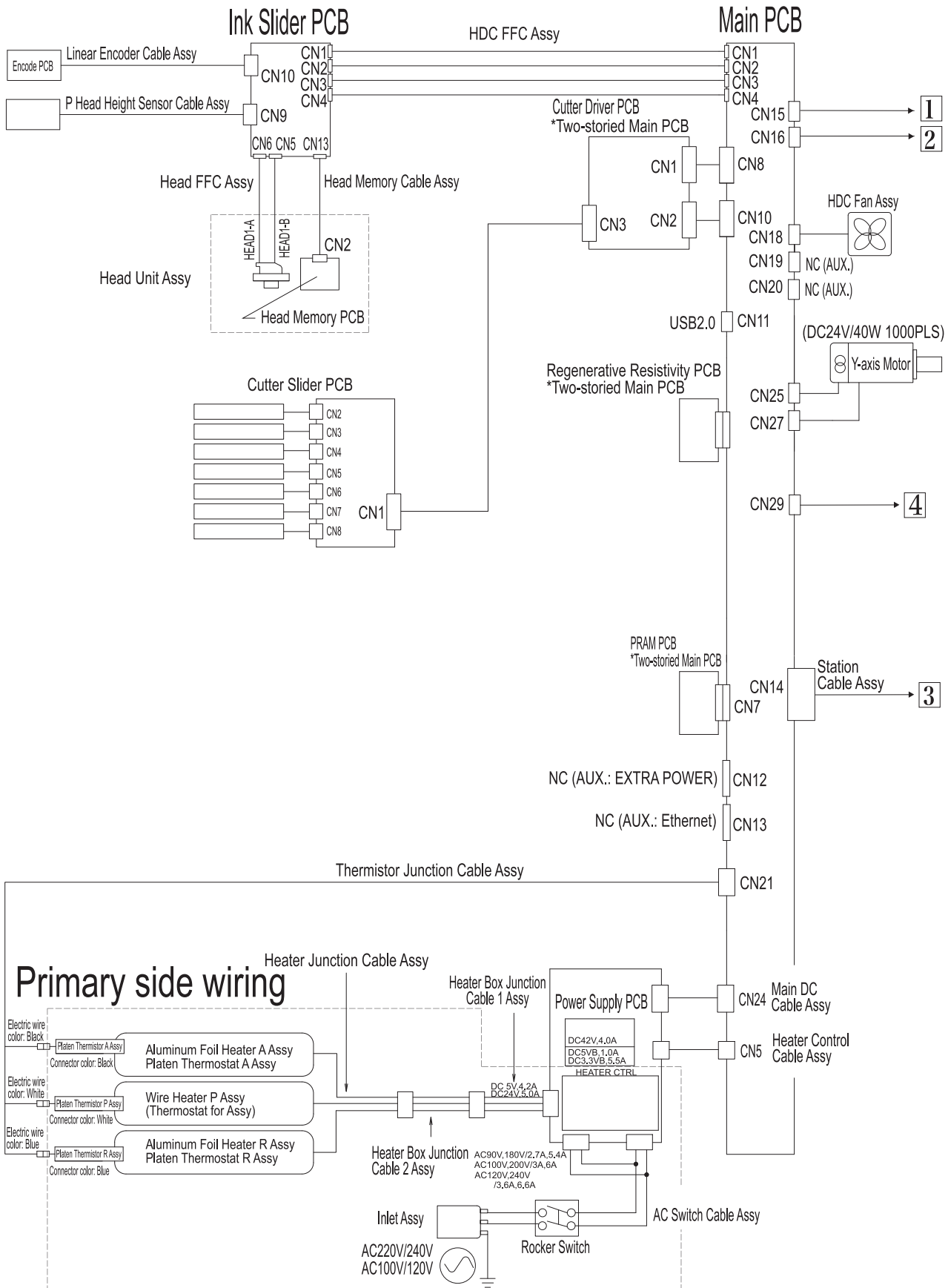

1
2
3
4
5
6
7
8

2.1.1 Connection Diagram Inside the Main Body

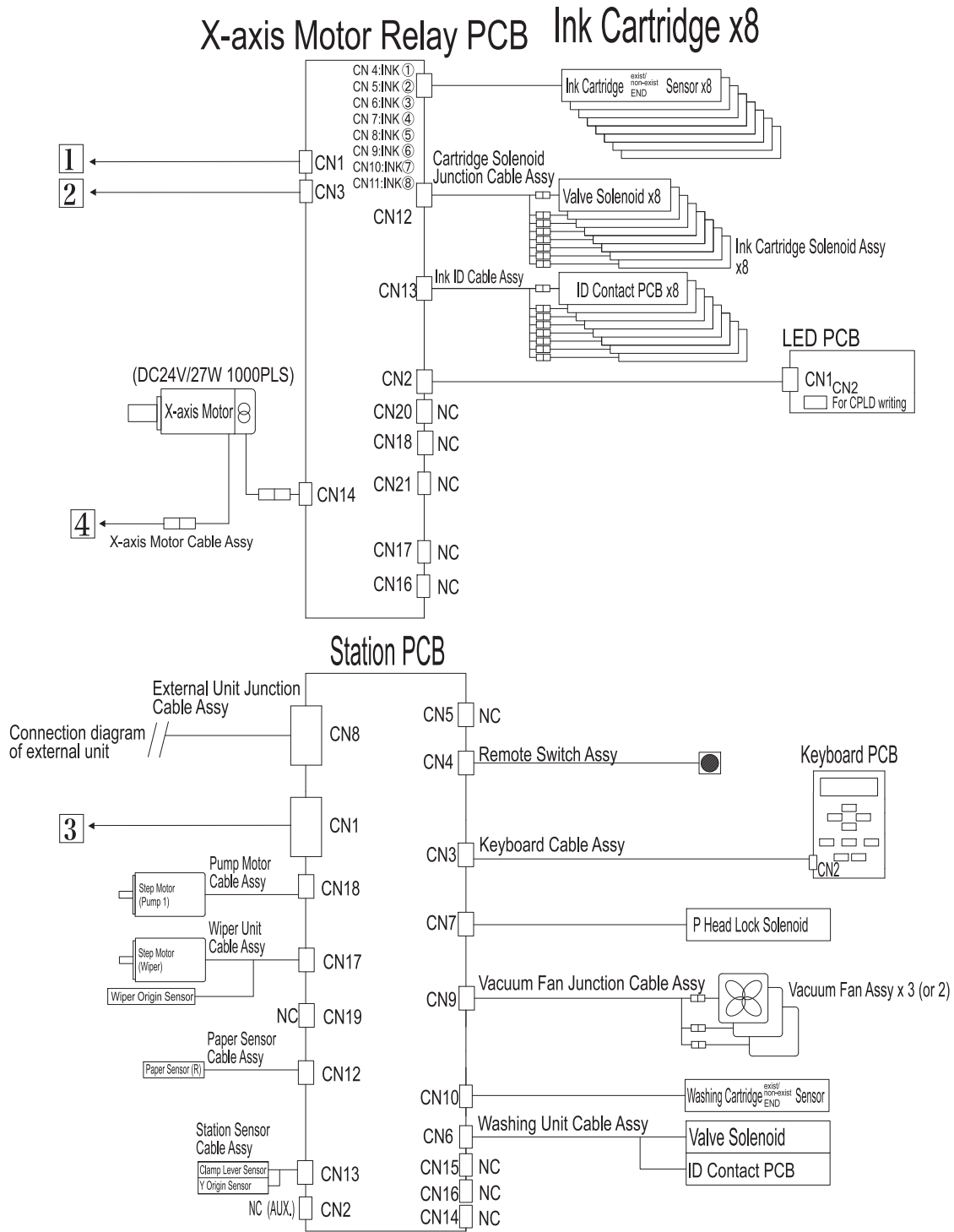

1

2

3

4

5

6

7

8

2.1.2 Connection Diagram Outside the Main Body

- 1
- 2
- 3
- 4
- 5
- 6
- 7
- 8

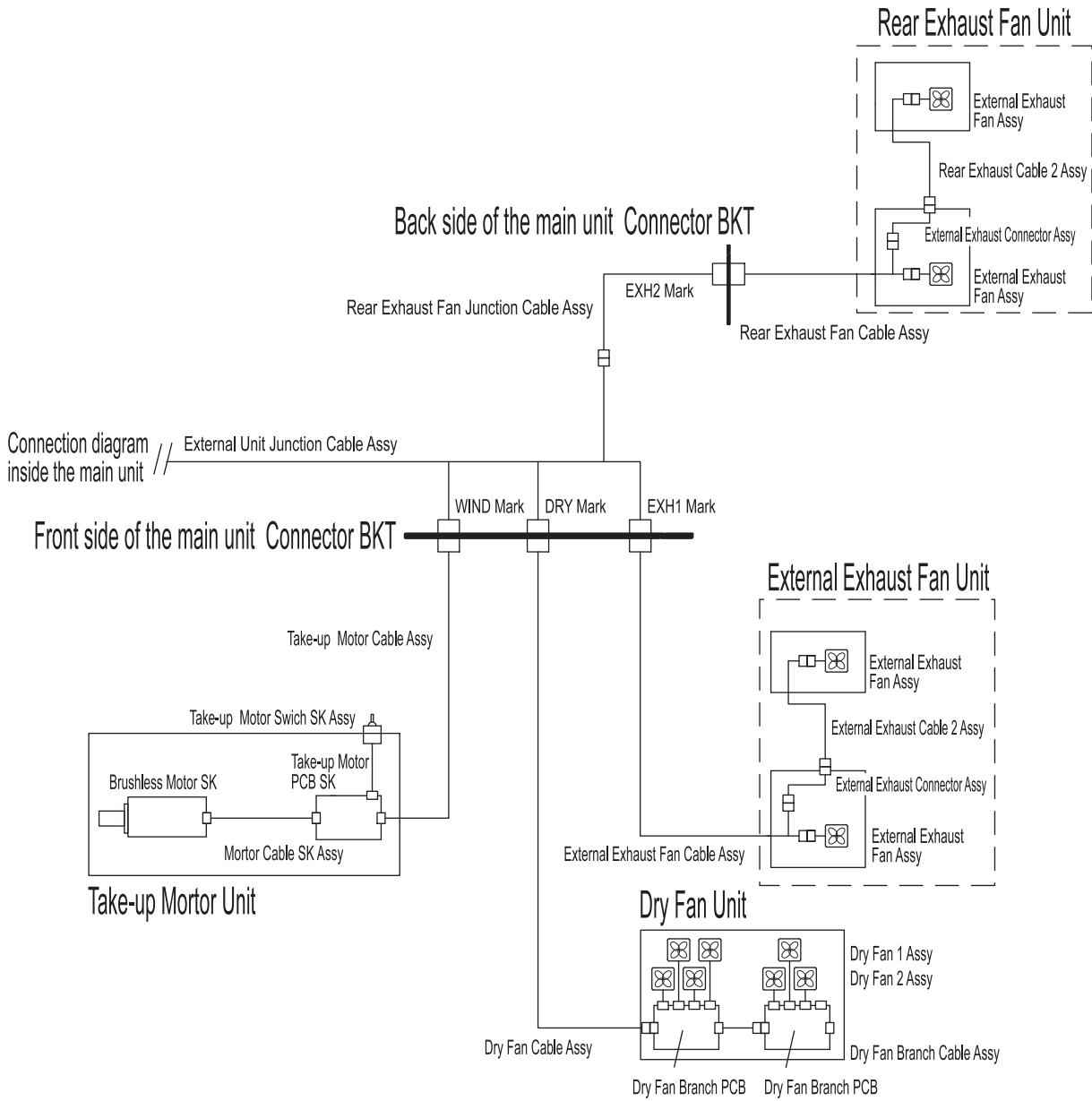

1

2

3

4

5

6

7

8

Electrical Parts		
2.1 Block Diagram	2.2 Operating Description	2.3 Circuit Board Specifications

2.2.1 Operation Explanation

1.2

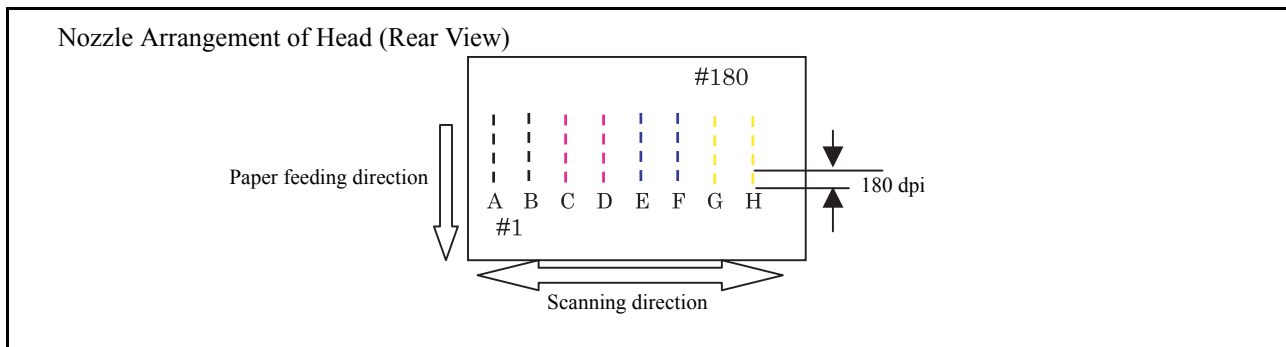

■ Outline

- This machine's print head carriage has one head with 180 nozzles (180 dpi) x 8 rows.
- Ink is ejected from the ink chamber by vibrating the piezoelectric elements of the heads. For this vibration waveform, the printer uses variable waveform which can permit 4-step expressions (L, M, S and none).
- The head is connected to the main PCB assy in the electrical box, and it is driven by a drive signal (COM waveform) applied to the piezo of one nozzle row for each of the eight rows of nozzles. FPGA (HDC) is mounted on the main PCB assy. The FPGA (HDC) applies the COM waveform in synchronization with the scale interval of the linear encoder scale and simultaneously sends the nozzle data to the head. In addition, the COM waveform is automatically corrected based on the registered head ID. It is also corrected based on the ID registered in the head memory, other information, and the ambient air temperature detected. (In case the head ID is not registered correctly, no ink may be ejected.)
- The main PCB assy has FPGA (PDC), which takes charge of image processing and controls the SDRAM picture memory (PRAM). PRAM is mounted on PRAM PCB assy and the PRAM PCB assy has a capacity of 128 MB. Of the data output from the host PC, the command part is analyzed by the CPU and the image part is transferred to the memory. The PRAM is a ring memory and when data for one scanning session has been accumulated, the heads start scanning. One scanning session creates images only in 180 dpi (6-colors / 6-colors+W / 7-colors / 8-colors) or in 360 dpi (4-colors) in the X direction. Therefore, the printer completes the image in the targeted resolution while feeding the media by a required distance.
- In case of printing by the use of pens and cutters, when the main PCB assy receives a command from I/F to implement printing, it buffers the command to a memory for exclusive use (32MB SDRAM) and starts printing by analyzing the command.
- This model is equipped with many I/Os such as step motors and sensors. If all of them were connected directly to the main PCB assy, routing the wiring and replacing the PCB would be difficult. To avoid this, a station PCB assy, X-axis motor relay PCB assy and head slider PCB assy are connected with the main PCB assy in series, reducing the number of signals exchanged. The signals are processed by the FPGA (IOC) mounted on the main PCB assy.

1

2

3

4

5

6

7

8

1

2

3

4

5

6

7

8

Electrical Parts		
2.1 Block Diagram	2.2 Operating Description	2.3 Circuit Board Specifications

2.3.1 Power Supply PCB Assy

1.1

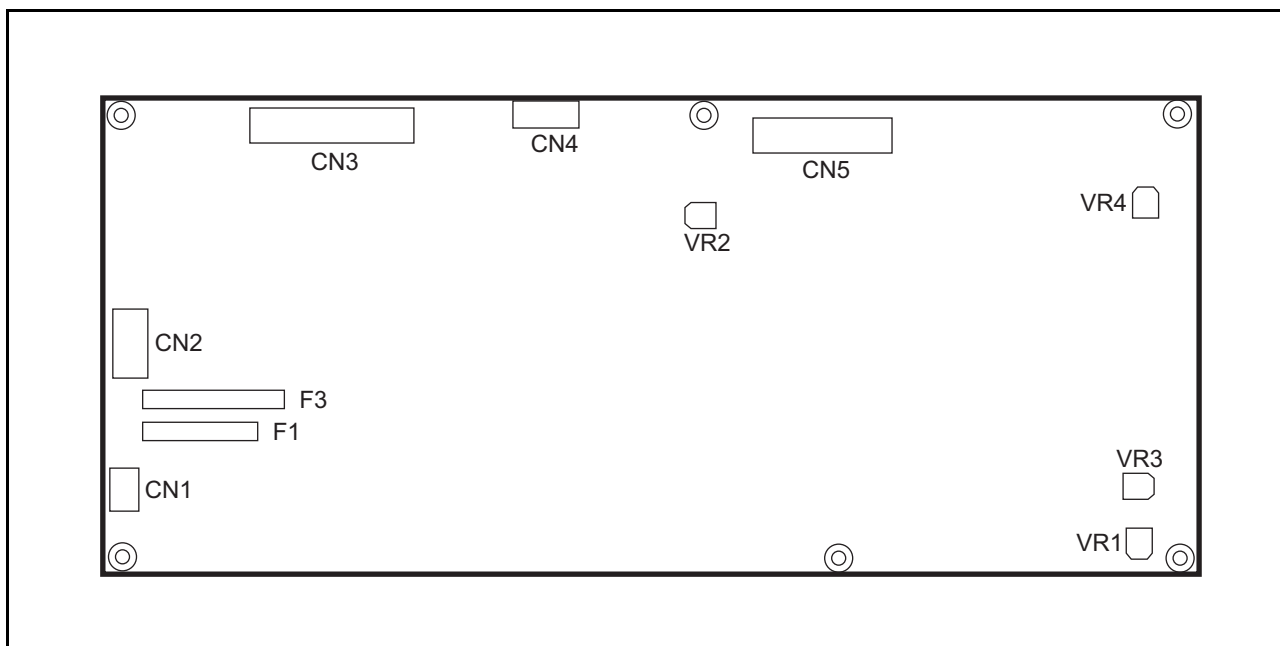

1

2

3

4

5

6

7

8

■ Outline

Board name: Power Supply PCB Assy

This PCB provides all the electrical power for controlling and driving functions.

■ Input and output of the power source

Input	AC100-120V, AC220-240, 50/60Hz
Output	+3.3SBV, 5.5A +5SBV, 1.0A +5V, 4.2A +24V, 5.0A +42V, 4.0A

■ Fuse rating

F1	T6.3AH/ 250V	φ5x20 mm	Input line to DC output circuit
F3	T15AH/ 250V	φ6.3x30 mm	Input line to heater

■ Connector specification

- CN1 AC input connector
Model number (JST): B2P3-VH (LF) (SN)

Pin	Terminal name	Type
1	AC-L	AC input supply
2	(NC)	(NC)
3	AC-N	AC input supply

- CN2 AC HEAT input connector
Model number (JST): B03P-VL *Media heater power input

Pin	Terminal name	Type
1	AC-L	AC input supply
2	(NC)	(NC)
3	AC-N	AC input supply

2.3.1 Power Supply PCB Assy

- CN3 Heater connector
Model number:

It is connected to the media heaters (Pre, Print, and After)

The element connection of the media heater is switched automatically according to the input voltage:

AC100-120V: Parallel connection

AC220-240V: Serial connection

Pin	Terminal name	Type	Pin	Terminal name	Type
1	HEAT3-1A	HEATER	12	HEAT3-1B	HEATER
2	HEAT3-2A	HEATER	13	HEAT3-2B	HEATER
3	HEAT3-3A	HEATER	14	HEAT3-3B	HEATER
4	HEAT3-4A	HEATER	15	HEAT3-4B	HEATER
5	HEAT3-THA	THERMAL	16	HEAT3-THB	THERMAL
6	HEAT2-1A	HEATER	17	HEAT2-1B	HEATER
7	HEAT2-2A	HEATER	18	HEAT2-2B	HEATER
8	HEAT2-THA	THERMAL	19	HEAT2-THB	THERMAL
9	HEAT1-1A	HEATER	20	HEAT1-1B	HEATER
10	HEAT1-2A	HEATER	21	HEAT1-2B	HEATER
11	HEAT1-THA	THERMAL	22	HEAT1-THB	THERMAL

- CN4 HEAT ON/OFF
Model number (MOLEX): B6B-XH-A(LF) (SN)

Pin	Terminal name	Type
1	HEAT1 ON	SIGNAL
2	0V	GND
3	HEAT2 ON	SIGNAL
4	0V	GND
5	HEAT3 ON	SIGNAL
6	0V	GND

- CN5 DC output connector
Model number (MOLEX): 5566-18A

Pin	Terminal name	Type	Pin	Terminal name	Type
1	+42V	DC power source	10	+42V	DC power source
2	+24V	DC power source	11	+24V	DC power source
3	0V	GND	12	0V	GND
4	0V	GND	13	0V	GND
5	+5V	DC power source	14	+5V	DC power source
6	+5SBV	DC power source	15	R/C(ON/OFF)	DC power source
7	+3.3SBV	DC power source	16	+3.3SBV	DC power source
8	0V	GND	17	0V	GND
9	0V	GND	18	0V	GND

Note: GND and FG are directly processed in the power supply (pattern).

■ Volume specification

Voltage	No	Adjustable range	Type
+3.3SBV	VR1	3.28 – 3.32	During standby or for main control
+5SBV	VR2	4.98 – 5.02	
+5V	VR4	4.98 – 5.02	For I/O control
+24V	–	–	
+42V	VR3	41.0 – 41.2	For discharge or motor drive

2.3.2 Main PCB Assy

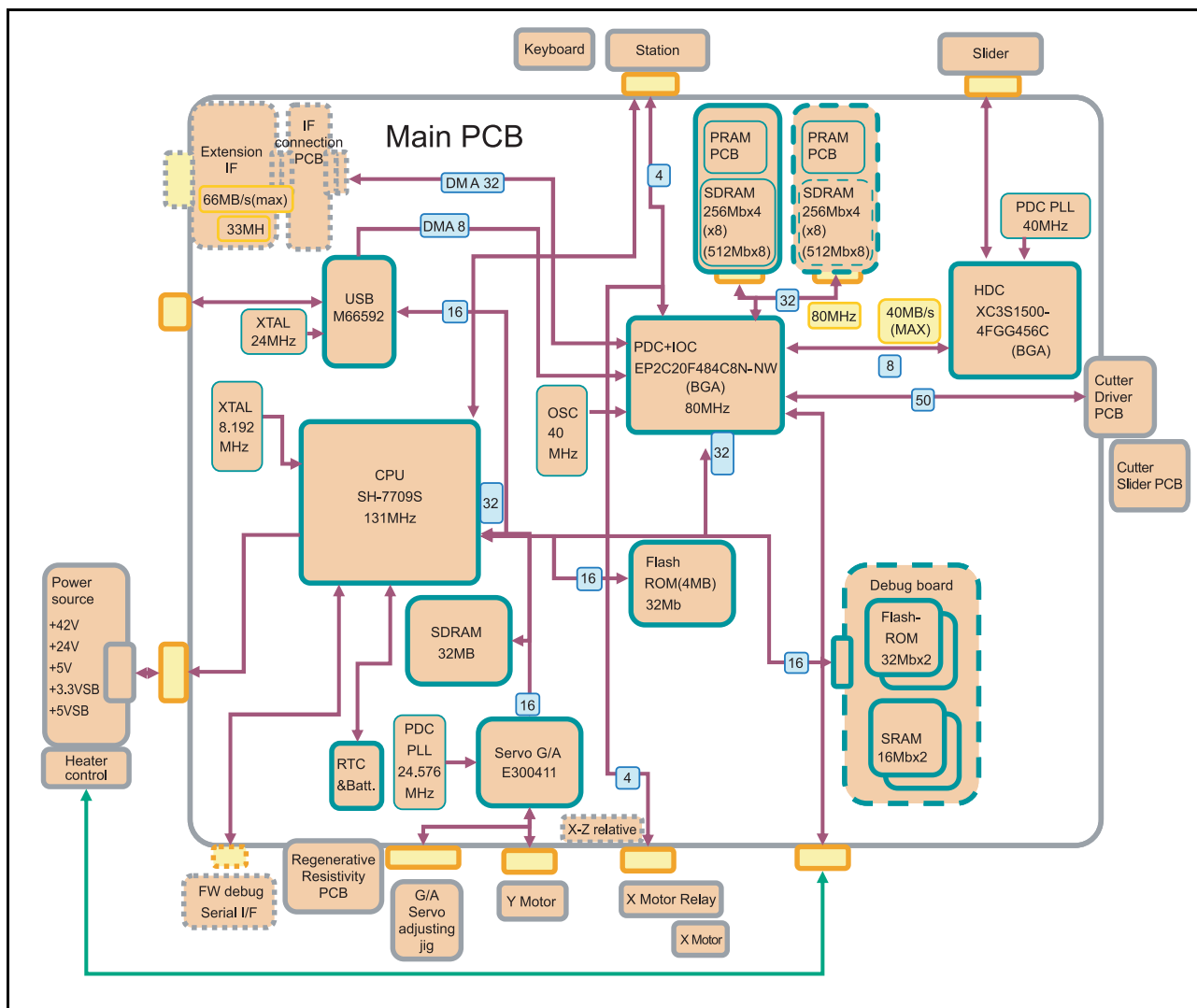

1

2

3

4

5

6

7

8

■ Outline

Board name: Main PCB Assy

The CPU used is SH-3 (RISC, 133MHz) made by Hitachi.

A program for the CPU is written in flash memory. Version up of this program is easily executed on site through I/F. The version up is carried out by downloading the program to PRAM through CPU and then by writing it in the flash memory.

When received data is read from I/F, the CPU writes the data in PRAM through PDC. Then the data, after being subjected to required processes by PDC-CTR, is transmitted to the HDC.

Receiving the data, the HDC creates head driving COM signals and nozzle data, and then transmits each data to the ink slider PCB Assy via HDC FFC cable.

In case of printing by the use of pens and cutters, when the main PCB Assy receives a command from I/F to implement printing, it buffers the command to a memory for exclusive use (32MB SDRAM) and starts printing by analyzing the command.

The main PCB Assy also has X, Y-axis motor driving circuit and other I/O control circuits.

2.3.2 Main PCB Assy

1.1

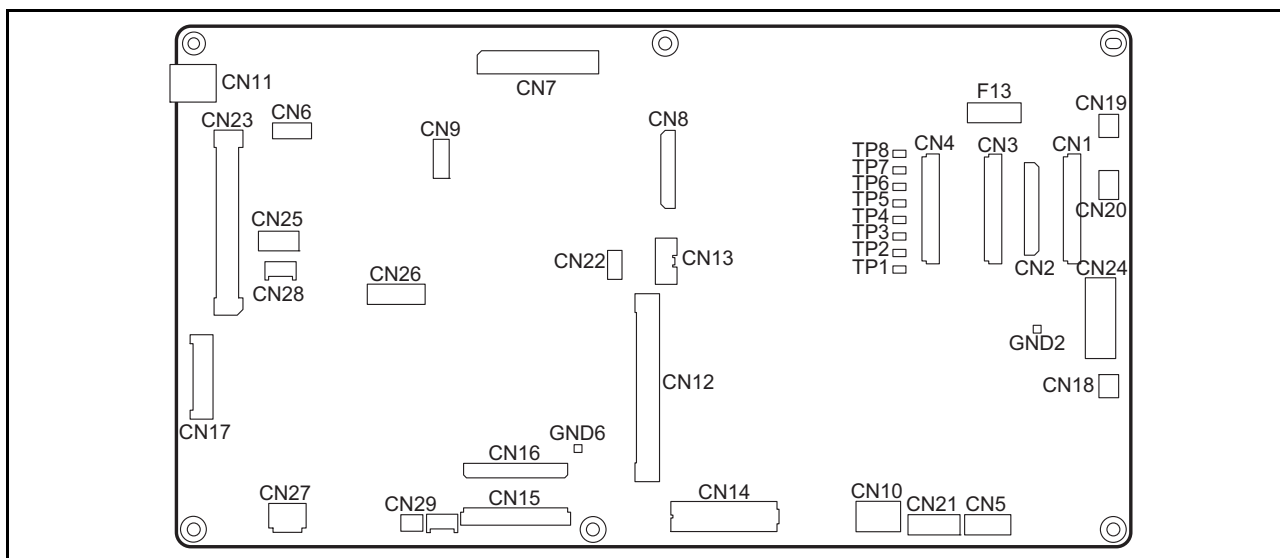

List of connectors

CN No	Pin	Connected to:	Remarks
CN1	30	Ink Slider PCB Assy	Head, IO signal
CN2	50	Ink Slider PCB Assy	Head signal
CN3	30	Ink Slider PCB Assy	Power source
CN4	30	Ink Slider PCB Assy	COM drive
CN5	6	Power Supply PCB Assy	Heater control
CN6	6	Debug Monitor	FPGA/CPLD writing
CN7	80	PRAM PCB Assy	
CN8	50	Cutter Driver PCB Assy	Control signal
CN9	6	Debug Monitor	FPGA
CN10	8	Cutter Driver PCB Assy	Power source
CN11	4	USB I/F	USB2.0
CN12	80	AUX.	Extension IF PCB Assy
CN13	5	AUX.	Extension IF PCB Assy
CN14	40	Station PCB Assy	
CN15	30	X-axis Motor Relay PCB Assy	
CN16	28	X-axis Motor Relay PCB Assy	
CN17	10	Regenerative Resistivity PCB Assy	
CN18	2	HDC Fan	
CN19	2	AUX.	AUX.
CN20	3	AUX.	
CN21	7	Thermistor	Media heater temperature detection
CN22	4	Serial Debug Monitor	AUX.
CN23	100	Debug Board	FW program writing
CN24	18	Power Supply PCB Assy	
CN25	5	Y-axis Motor Encoder	
CN26	8	G/A Debug Monitor	AUX.
CN27	3	Y-axis Motor	
CN28	4	Not used	
CN29	2	X-axis Motor	

Test point

Terminal name	Application
GND2, 6	GND
TP1-8	COM voltage (1-8)

Fuse rating

F13	0.375A/ 125V	42 V power supply for heads
-----	--------------	-----------------------------

1

2

3

4

5

6

7

8

2.3.3 PRAM PCB Assy

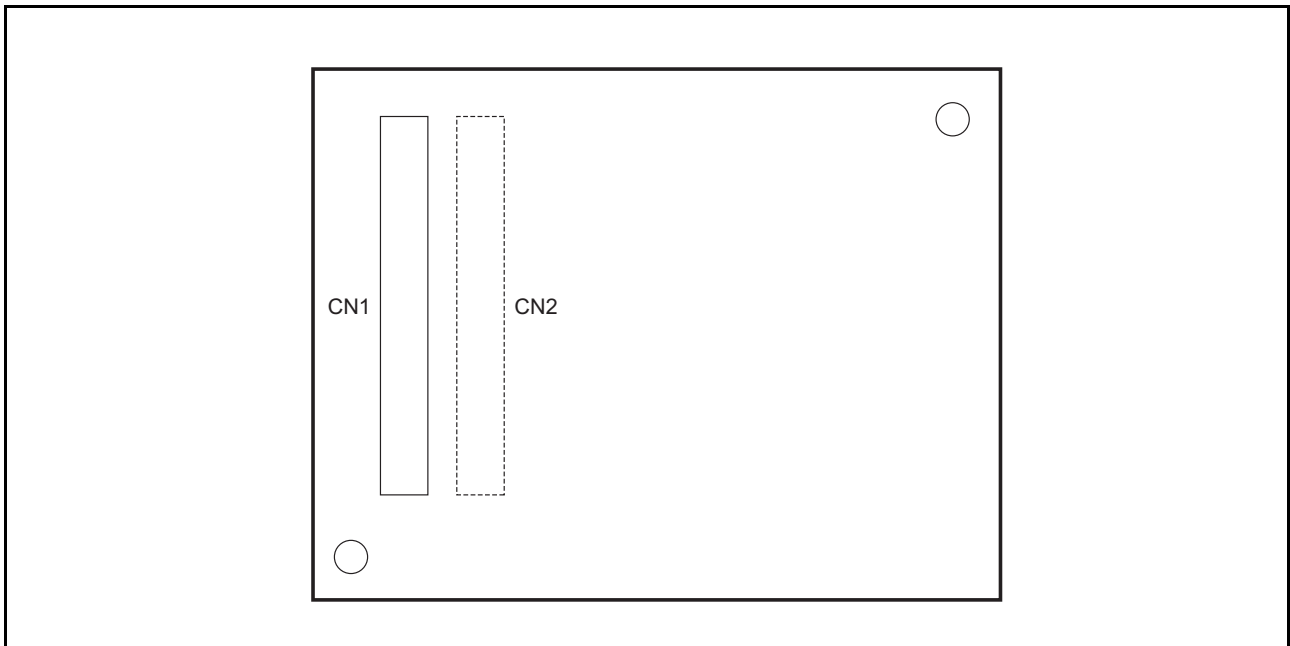

1

2

3

4

5

6

7

8

■ Outline

Board name: 128MB PRAM PCB Assy

Is located on the main PCB assy inside the electrical box.
128 MB picture memory is mounted.

■ List of connectors

CN No	Pin	Connected to:	Remarks
CN1	80	Main PCB Assy	
CN2	80	AUX.	

2.3.4 Regenerative Resistivity PCB Assy

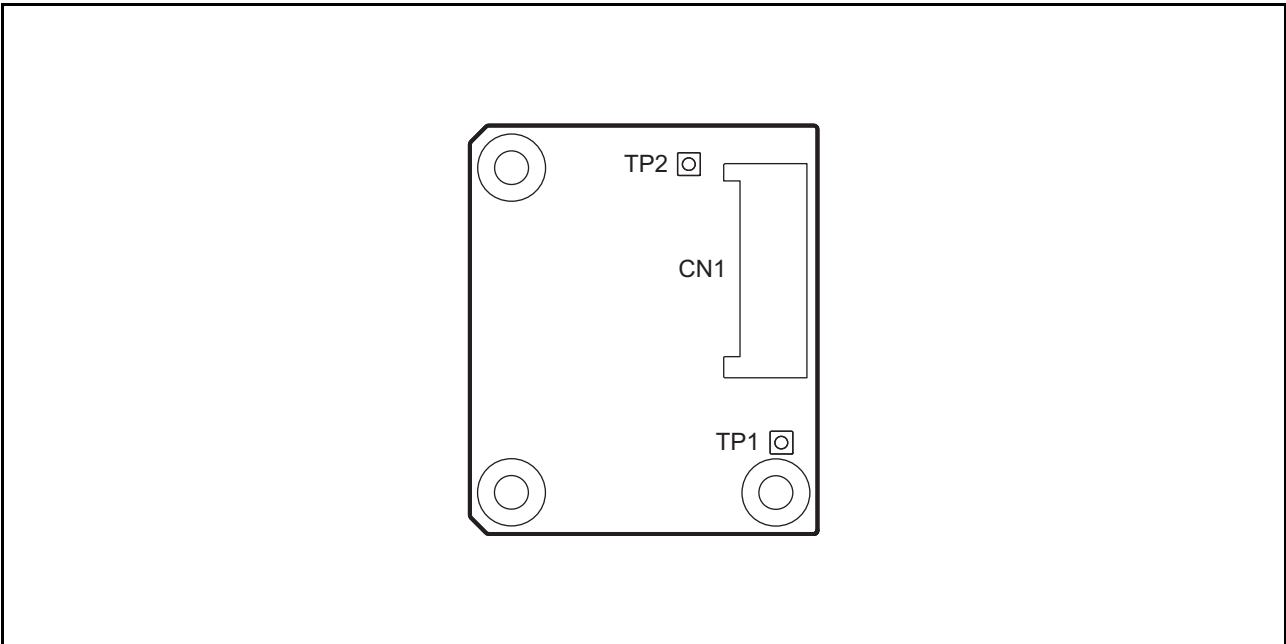

■ Outline

Board name: Regenerative Resistivity PCB Assy

Is located on the main PCB assy inside the electrical box.

Controls counter electromotive voltage by supplying the electrical power to the motor via this PCB.

■ List of connectors

CN No	Pin	Connected to:	Remarks
CN1	10	Main PCB Assy	Power supply to the X and Y-axis motors

■ Test point

Terminal name	Application
TP1	+42V
TP2	Power supply voltage of the motor

1

2

3

4

5

6

7

8

2.3.5 Cutter Driver PCB Assy

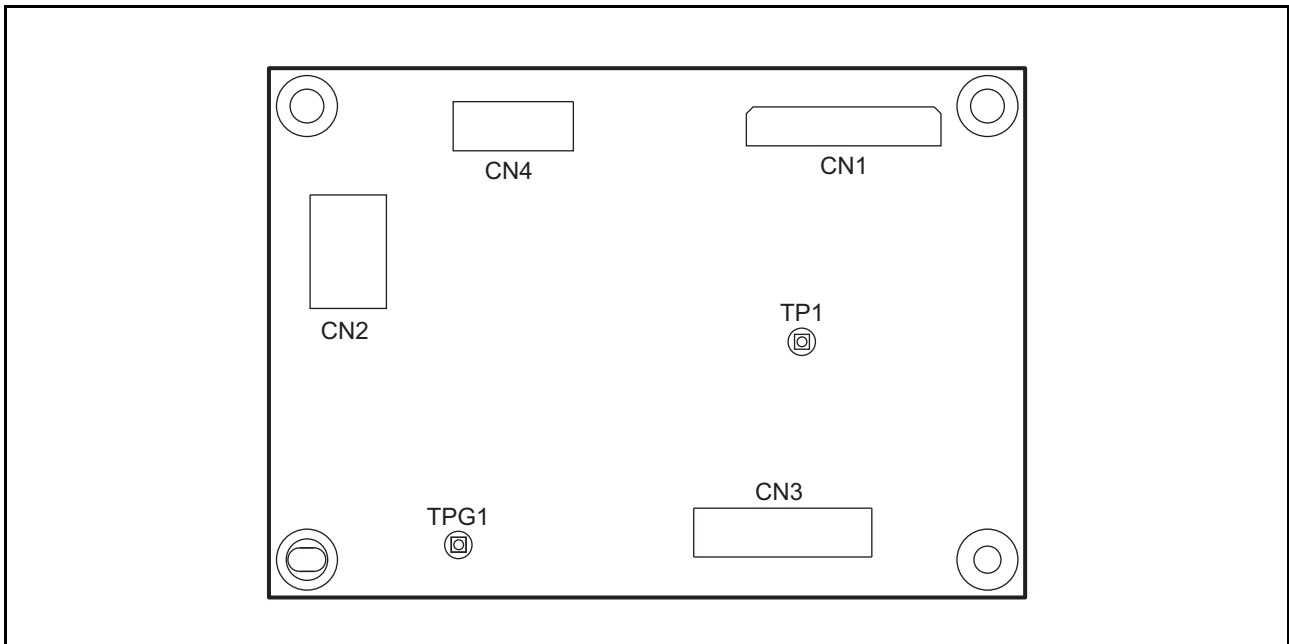

■ Outline

Board name: Cutter Driver PCB Assy

Is located on the main PCB Assy inside the electrical box.
Controls I/O for the pen head, mark sensor and PR sensor.

■ List of connectors

CN No	Pin	Connected to:	Remarks
CN1	50	Main PCB Assy	Control
CN2	8	Main PCB Assy	Power source (for solenoids)
CN3	17	Cutter Slider PCB Assy	Control / Power source

■ Test point

Terminal name	Application
TP1	Output voltage of mark sensor
TPG1	GND

1

2

3

4

5

6

7

8

2.3.6 Station PCB Assy

1.1

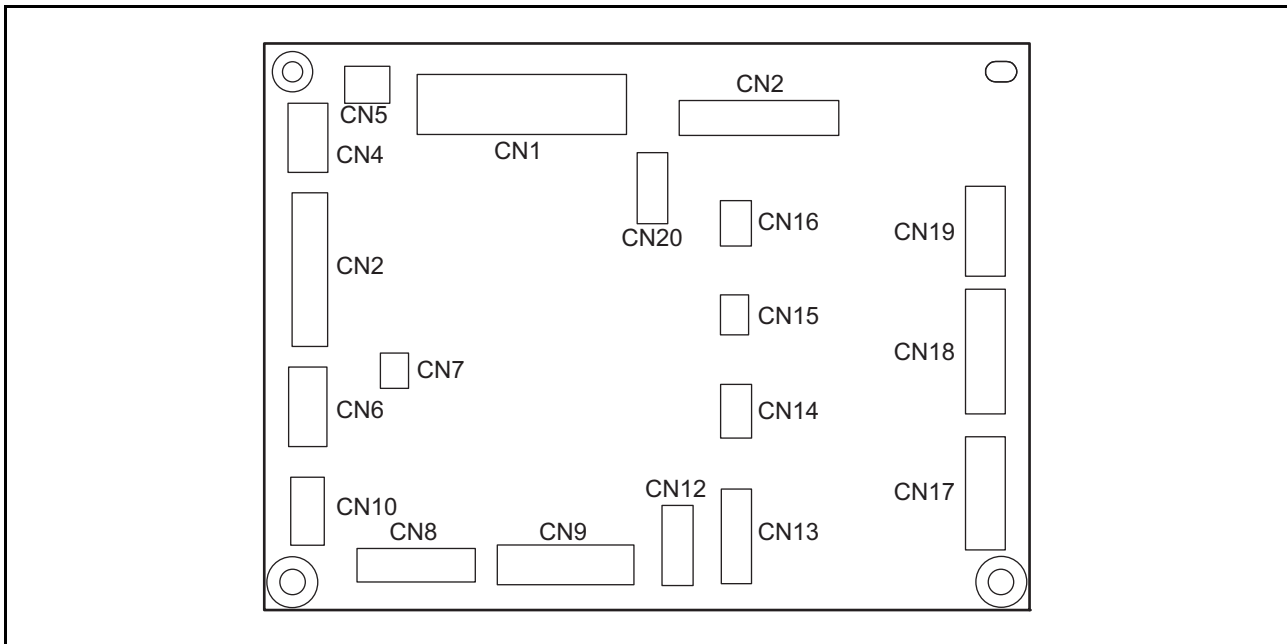

■ Outline

Board name: Station PCB Assy

Is located on the side panel inside the right cover.

The pump motor, vacuum fan, paper sensor, Y-origin sensor and other main body control I/Os are connected to this PCB.

■ List of connectors

CN No	Pin	Connected to:	Remarks
CN1	40	Main PCB Assy	
CN2	20	AUX.	
CN3	24	Keyboard	
CN4	4	Sleep Switch	
CN5	2	AUX.	
CN6	4	Washing Cartridge, ID Contact PCB Assy	
CN7	2	P Head Lock Solenoid	
CN8	18	External Unit Output	Take-up, Exhaust Fan, Dry Fan
CN9	10	Vacuum Fan	
CN10	4	Washing Cartridge Sensor	
CN11	-	Not used	
CN12	7	Paper Sensor (R)	
CN13	9	Clamp Sensor, Y-origin Sensor	
CN14	4	AUX.	
CN15	3	AUX.	
CN16	3	AUX.	
CN17	8	Wiper Unit	Wiper Motor, Wiper-origin
CN18	9	Pump Motor	
CN19	6	AUX.	

1

2

3

4

5

6

7

8

2.3.7 X-axis Motor Relay PCB Assy

1.1

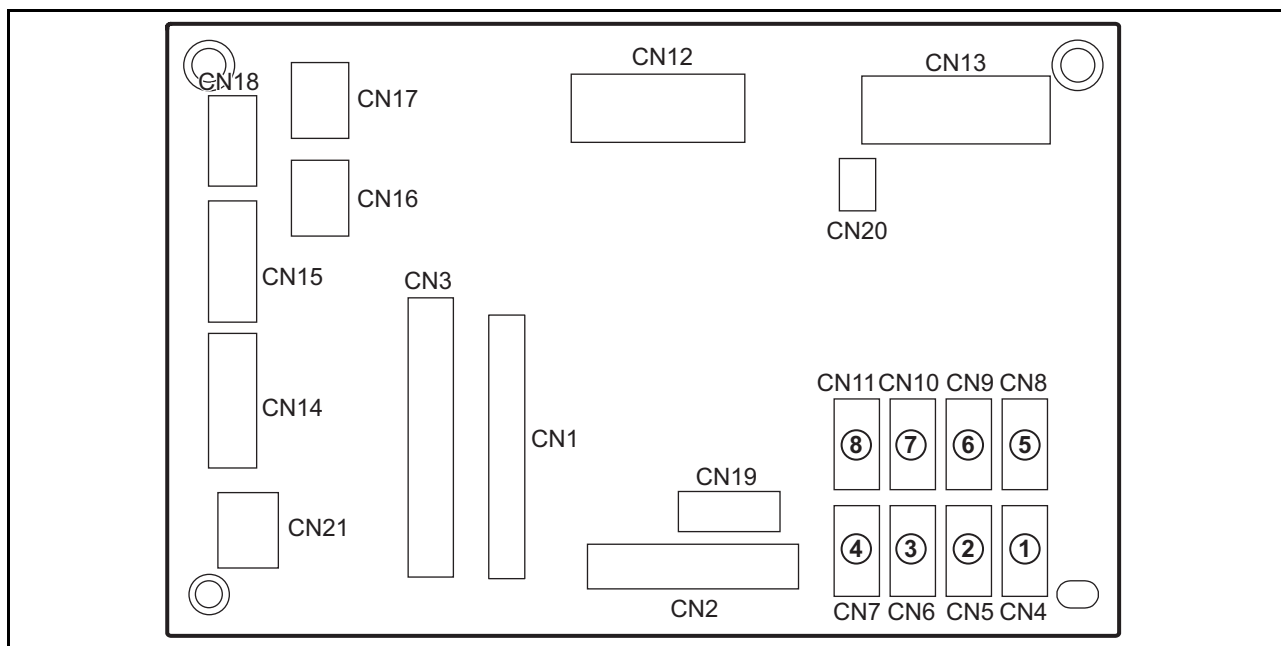

■ Outline

Board name: X-axis Motor Relay PCB Assy

Is located on the back of the ink cartridge unit inside the left cover.

The solenoids of the 8 ink cartridges, ID, ink near end sensor, cartridge sensor, LED PCB Assy, cover sensor, maintenance cover sensor, etc. are connected to it.

■ List of connectors

CN No	Pin	Connected to:	Remarks
CN1	28	Main PCB Assy	
CN2	20	LED PCB Assy	
CN3	30	Main PCB Assy	
CN4	4	Ink Cartridge 1	
CN5	4	Ink Cartridge 2	
CN6	4	Ink Cartridge 3	
CN7	4	Ink Cartridge 4	
CN8	4	Ink Cartridge 5	
CN9	4	Ink Cartridge 6	
CN10	4	Ink Cartridge 7	
CN11	4	Ink Cartridge 8	
CN12	16	Ink Solenoid (1-8)	
CN13	18	Ink ID (1-8)	
CN14	6	X-axis Motor Encoder	
CN15	5	Not equipped	AUX.
CN16	2	AUX.	
CN17	2	AUX.	
CN18	3	AUX.	AUX.
CN19	6	Not equipped	AUX.
CN20	2	AUX.	AUX.
CN21	2	AUX.	

1

2

3

4

5

6

7

8

2.3.8 Ink Slider PCB Assy

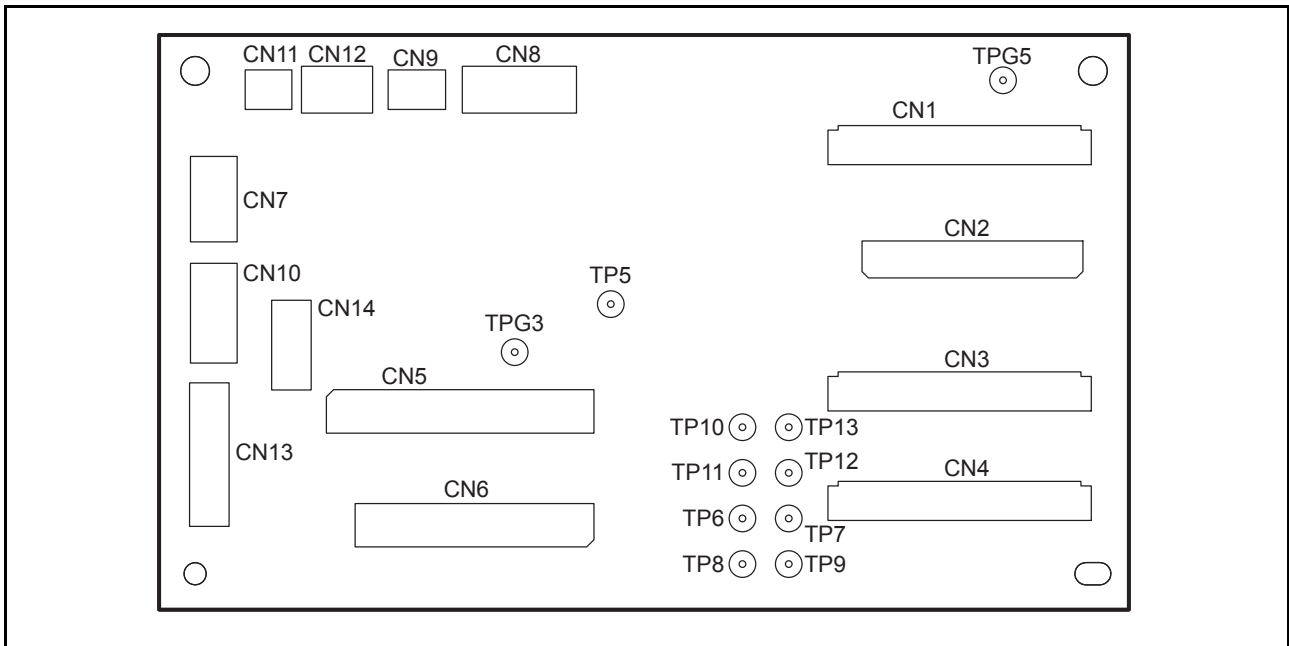

■ Outline

Board name: Ink Slider PCB Assy

Is located on the top of the print part slider.

FFC from main PCB Assy is connected to this PCB to relay signals to print head. In addition, the encoder PCB Assy, head height sensor, etc. are connected to this PCB.

■ List of connectors

CN No	Pin	Connected to:	Remarks
CN1	30	Main PCB Assy	IO control
CN2	50	Main PCB Assy	Head control
CN3	30	Main PCB Assy	Power source
CN4	30	Main PCB Assy	COM waveform
CN5	35	Print Head	
CN6	31	Print Head	
CN7	4	AUX.	
CN8	6	AUX.	
CN9	3	Head Height Sensor	
CN10	5	Linear Encoder PCB Assy	
CN11	2	AUX.	
CN12	3	AUX.	
CN13	11	Head Memory PCB Assy	Head memory
CN14	6	None	AUX.

■ Test point

Terminal name	Application
TP5	VBS (+8V)
TP6-13	COM1-8 (A-H)
TPG3, 5	GND

1

2

3

4

5

6

7

8

2.3.9 Cutter Slider PCB Assy

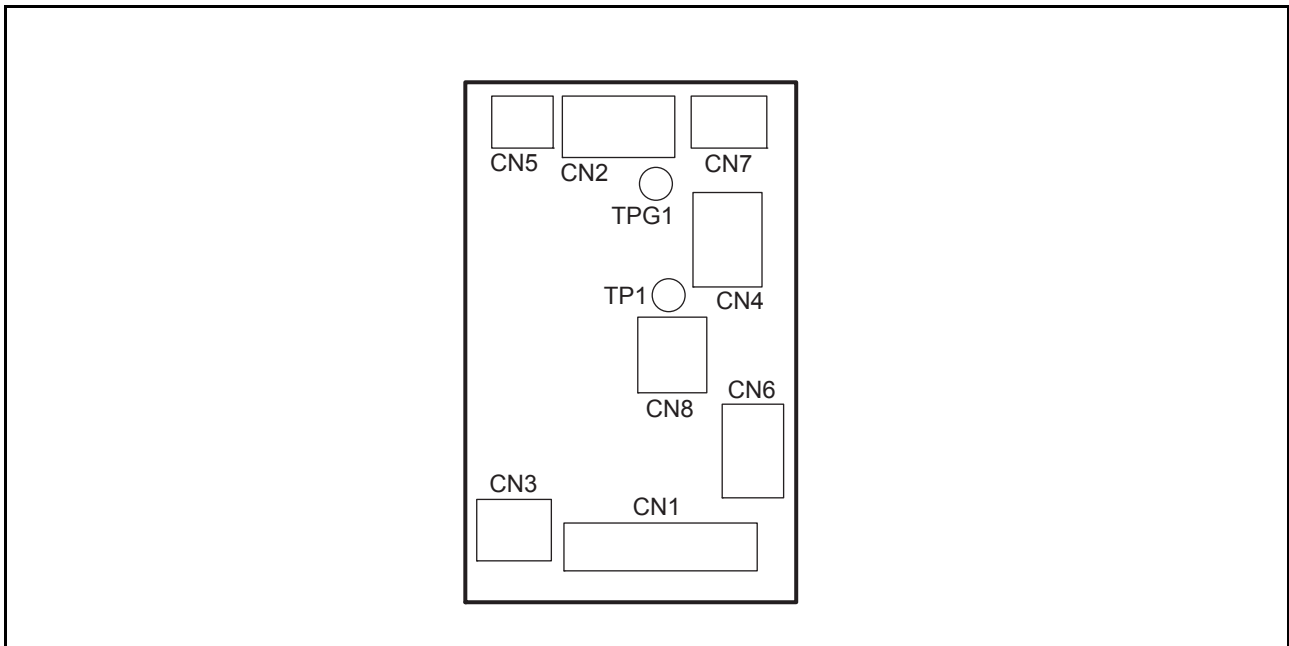

1

2

3

4

5

6

7

8

■ **Outline**

Board name: Cutter Slider PCB Assy

Is located on the top of the head part slider.

FFC from cutter driver PCB Assy is connected to this PCB to relay signals to pen head.

Connecting sensor, mark sensor, auto cutter blade, etc. are connected to this PCB.

■ **List of connectors**

CN No	Pin	Connected to:	Remarks
CN1	17	Cutter Driver PCB Assy	IO
CN2	4	Mark Sensor	
CN3	2	Pen Solenoid	
CN4	3	Connecting Sensor	
CN5	2	LED Pointer	
CN6	3	Auto Cutter Blade Solenoid	
CN7	3	PR Sensor	
CN8	2	PR Switch Solenoid	

■ **Test point**

Terminal name	Application
TP1	Output voltage of mark sensor
TPG1	GND

2.3.10 Head Memory PCB Assy

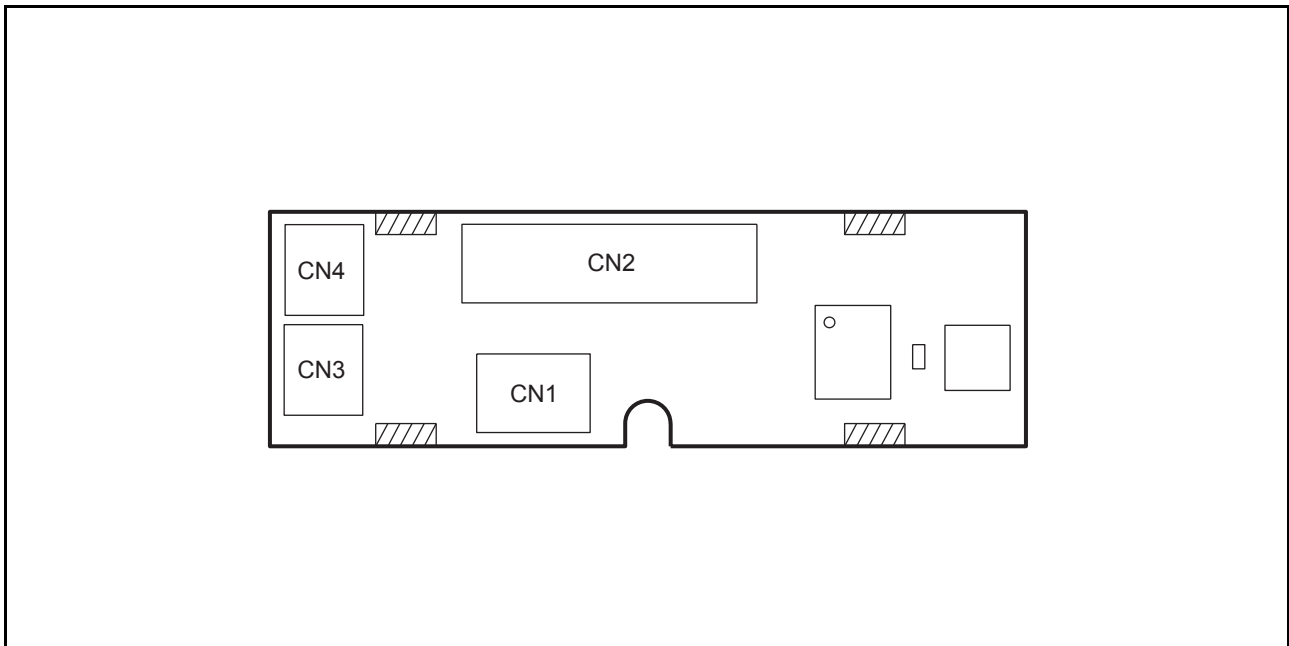

■ Outline

Board name: Head Memory PCB Assy

Stores Head ID information. Is provided together with the head(s), and does not operate independently.

■ List of connectors

CN No	Pin	Connected to:	Remarks
CN1	3	Head Heating Thermistor	Not used.
CN2	11	Ink Slider PCB Assy	
CN3	2	Head Heating Heater	Not used.
CN4	2	Head Heating Heater	Not used.

1

2

3

4

5

6

7

8

2.3.11 LED PCB Assy

1.1

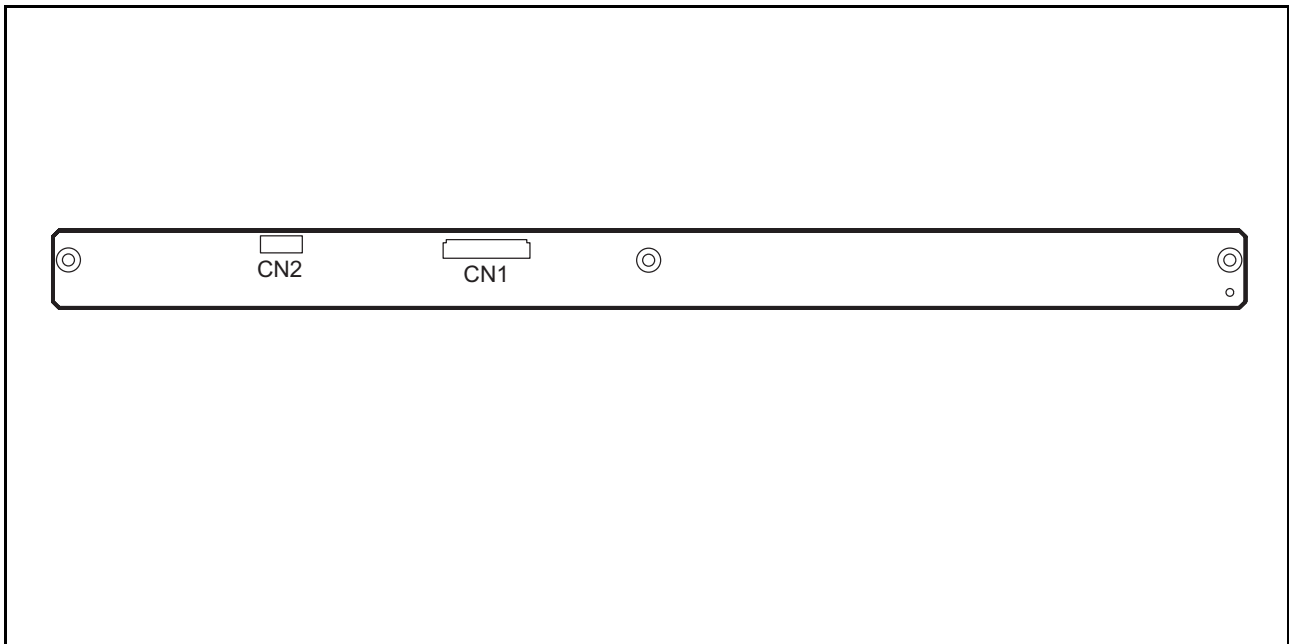

1

2

3

4

5

6

7

8

■ Outline

Board name: LED PCB Assy

Is located at the front of the ink cartridge unit inside the left cover.

The FFC from the X-axis relay PCB Assy is connected to this PCB. The LEDs (green, red) corresponding to each slot of the cartridge is displayed on the LED PCB Assy.

■ List of connectors

CN No	Pin	Connected to:	Remarks
CN1	20	X-axis Relay PCB Assy	
CN2	6	None	AUX.

2.3.12 Keyboard PCB Assy

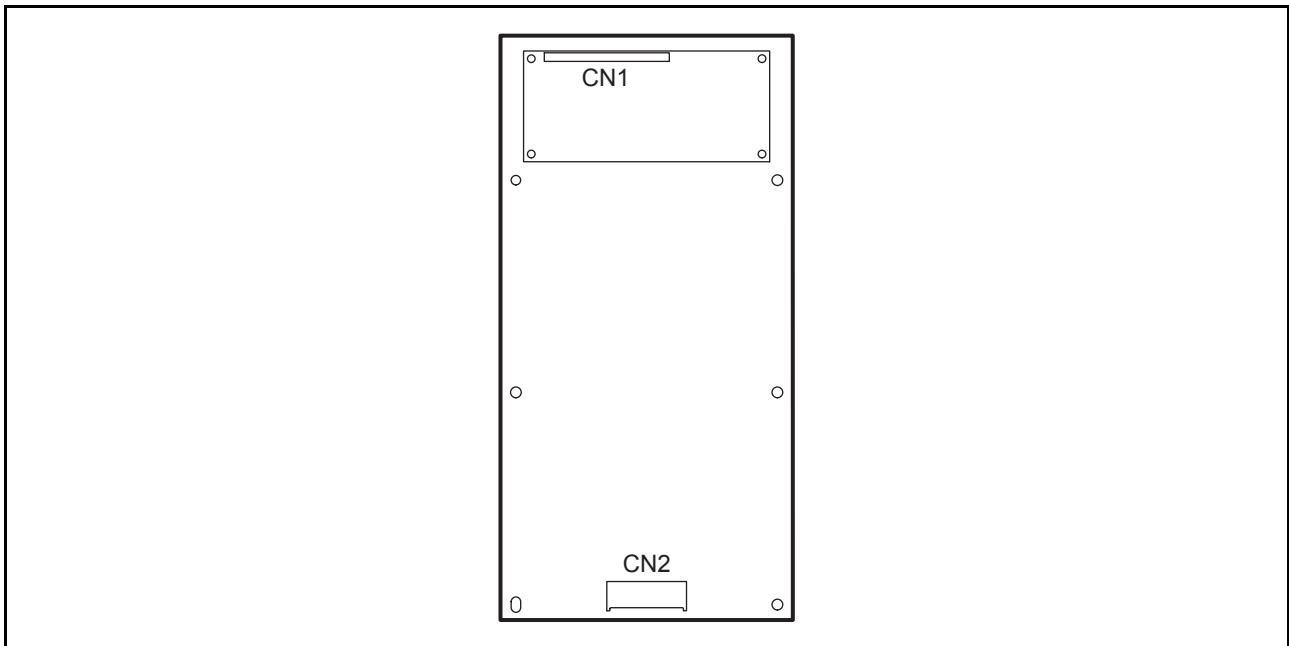

■ Outline

Board name: Keyboard PCB Assy

Has LCD with 2 lines of 20 characters and key switches. It is connected to the station PCB Assy with a keyboard cable.

■ List of connectors

CN No	Pin	Connected to:	Remarks
CN1	16	LCD PCB Assy	Control
CN2	24	Station PCB Assy	

1

2

3

4

5

6

7

8

2.3.13 Take-up PCB Assy

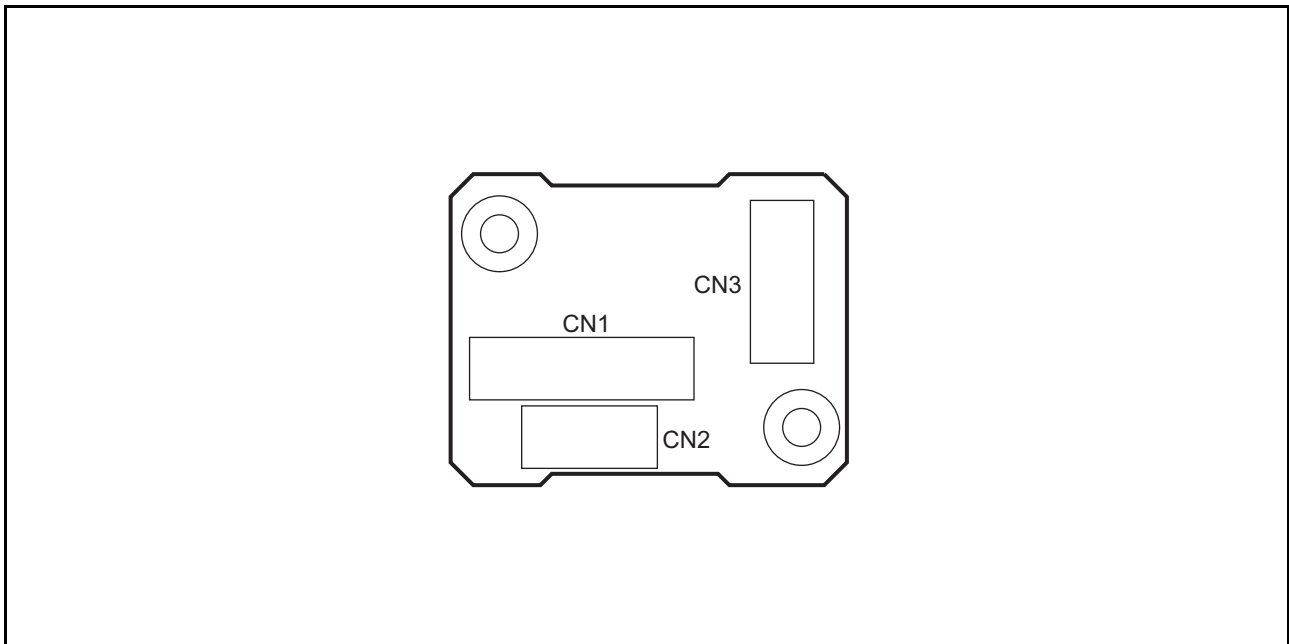

■ Outline

Board name: Take-up PCB SK Assy

This PCB is connected to the station PCB assy via external connector, which can be attached or removed by users. It is used inside the take-up motor unit, as a junction between the station PCB assy and take-up motor.

■ List of connectors

CN No	Pin	Connected to:	Remarks
CN1	9	External Connector Cable (Station PCB Assy)	Power source
CN2	5	Start, direction changing switch	
CN3	6	Take-up Motor	

1

2

3

4

5

6

7

8

1

2

3

4

5

6

7

8

Workflow		
3.1 Ink Related Parts	3.2 Cut Head Carriage	3.3 Driving Parts
3.4 Electrical Parts		

3.1.1 Replacement of the Head Unit

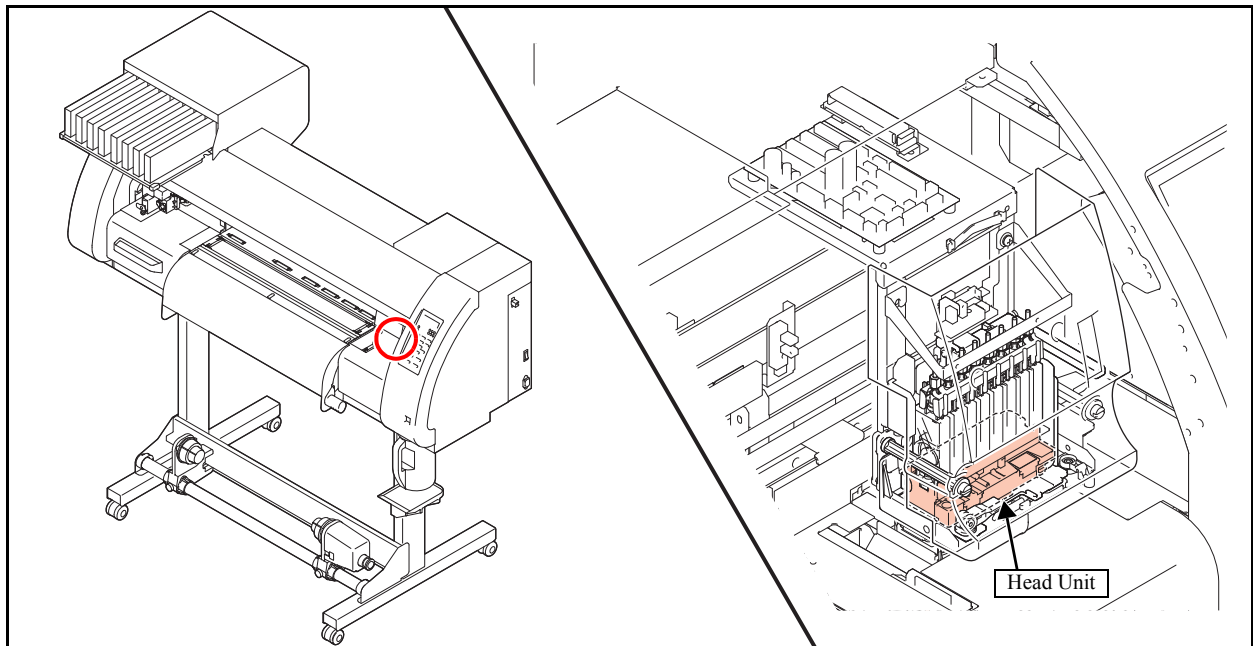

1

2

3

4

5

6

7

8

■ List of replacement procedures

Item	Work operation	Description	Ref.
Covers	1. <input type="checkbox"/> Removal of covers, etc.	Remove the front cover and print head cover.	6.1.1
Print Head Unit Assy	2. <input type="checkbox"/> Preparation of the new head and cleaning of its inside	Fill the head with the water-based transportation liquid (S-46) before shipment from the factory. If ink is charged while the head is in original state (the S-46 is inside the head), it reacts chemically with the solvent ink, with a precipitate being formed. Therefore, until a new head is installed, it is necessary to clean the head with the washing liquid (MS washing liquid) used exclusively when replacing the S head.	6.2.1
	3. <input type="checkbox"/> Removal of the head.	Remove the damper before removing the disused head.	6.2.2
	4. <input type="checkbox"/> Mounting of the head.	Mount the new head which has been cleaned.	6.2.3
	5. <input type="checkbox"/> Check of the head ID	Check the head ID and enter it manually when necessary. (Normally, manual entry is not necessary because writing is carried out automatically.)	4.2.6
Ink	6. <input type="checkbox"/> Ink charge into the head	Fill the head with ink and carry out test plotting. Check for any nozzle outs or flight deflection of ink droplets.	
Check	7. <input type="checkbox"/> Head slant adjustment	Mechanically adjust the replaced head.	4.2.1
	8. <input type="checkbox"/> Correction of dot position (Press the key [ADJUST])	Adjust dot locations.	4.2.2
	9. <input type="checkbox"/> Correction of dot position (Press the key [SET UP])	Make adjustment by (pressing the key) [DROP.POScorrect] of "user mode".	
Covers	10. <input type="checkbox"/> Mounting of the covers	Mount the covers that have been removed.	6.1.1



Be sure to wear protective glasses and working gloves during the operation. Ink may get into your eyes depending on the working condition, or hand skin may get rough if you touch the ink.

3.1.2 Replacement of the Cap Assy

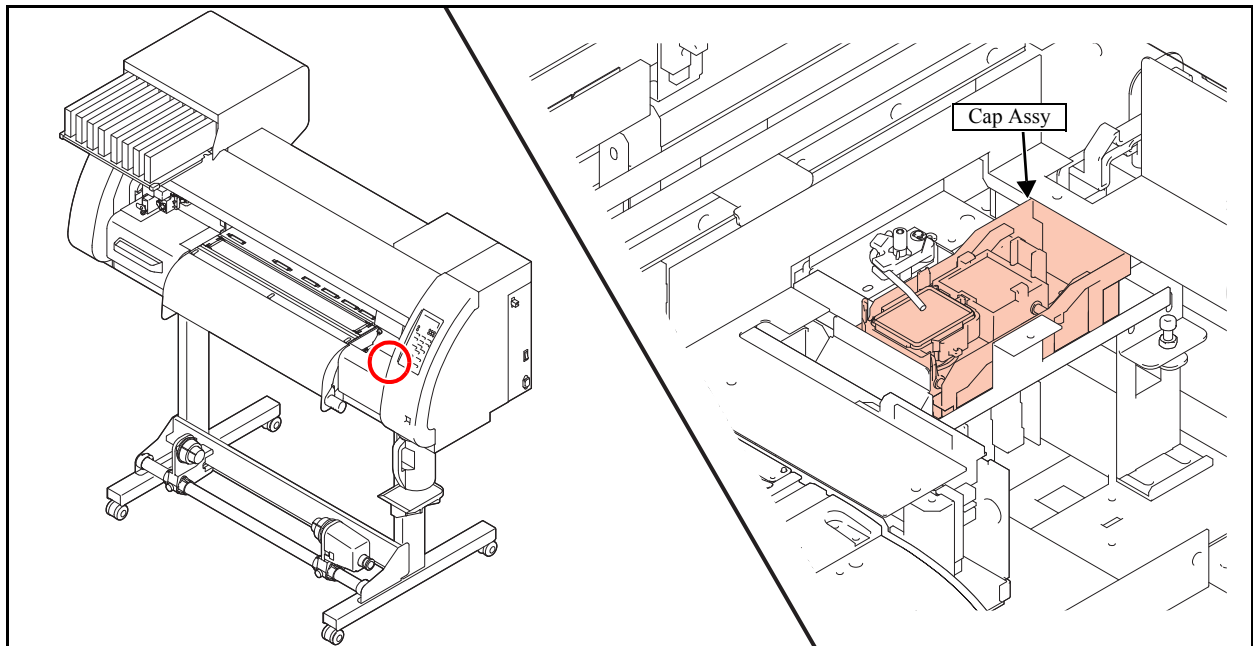

1

2

3

4

5

6

7

8

■ List of replacement procedures

Item	Work operation	Description	Ref.
Covers	1. <input type="checkbox"/> Removal of covers, etc.	Remove the station cover U, W ink guard and wiring cover.	6.1.1
Cap Assy	2. <input type="checkbox"/> Removal of the cap assy.	Remove the cap assy while pushing the PC pipes to the side.	6.2.6
	3. <input type="checkbox"/> Mounting of the cap assy.	Attach the cap assy while pushing it toward you.	6.2.6
	4. <input type="checkbox"/> Adjustment of the capping	Carry out "CAPPING" (by using the key) [# ADJUST]. CAPPING POS: 3 mm to the right from the uppermost position of the cap slider. AirPullPOS.: The point exactly where the head comes into contact with the cap (left end) FlushingPOS: Position of the head and the left end of the cap, which sets the clearance between them at 1 mm. WiperPOS(X): The point where the center of the wiper is aligned with the center of the head	4.2.5
Check	5. <input type="checkbox"/> Cleaning operation	Check whether each assembly and adjustment has been carried out properly by conducting [WIPER CLEANING] operation.	
Covers	6. <input type="checkbox"/> Mounting of the covers.	Mount the covers that have been removed.	6.1.1



Be sure to wear protective glasses and working gloves during the operation.
Ink may get into your eyes depending on the working condition, or hand skin may get rough if you touch the ink.

3.1.3 Replacement of the Cartridge Assy

1.1

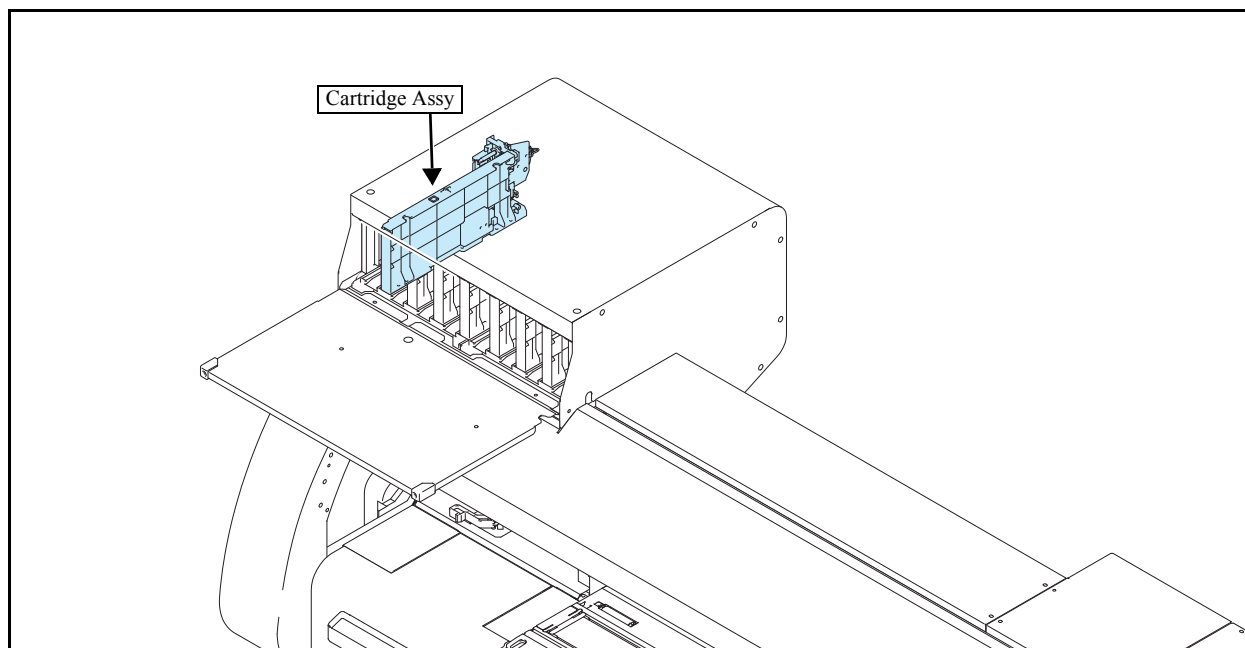

1

2

3

■ List of replacement procedures

Item	Work operation	Description	Ref.
Covers	1. <input type="checkbox"/> Removal of covers, etc.	Remove the ICU cover, cartridge holder B and cartridge base U.	6.1.1
Ink	2. <input type="checkbox"/> Ink discharging	Discharge ink by carrying out [HEAD WASH] of the maintenance function.	4.2.7
Cartridge Assy	3. <input type="checkbox"/> Removal of the joint.	Remove the joint from corresponding cartridge. Take care not to spill ink.	
	4. <input type="checkbox"/> Removal of the cartridge.	Disconnect the cables of corresponding cartridges from the connector to remove the cartridges.	
	5. <input type="checkbox"/> Mounting of the cartridge.	Mount the cartridge.	
	6. <input type="checkbox"/> Mounting of the joint.	Mount the joint which has been removed.	
Check	7. <input type="checkbox"/> Check on the sensors	Check whether the exist/non-exist sensor, the near end sensor and the contact PCB assy of corresponding cartridges function normally, by conducting ink cartridge test. It is preferable to conduct a check by actually using cartridges.	5.1.14
Ink	8. <input type="checkbox"/> Ink filling	Fill up the ink channels with ink. Check for any nozzle outs by conducting a test plotting.	
Covers	9. <input type="checkbox"/> Mounting of the covers.	Mount the covers that have been removed.	6.1.1

4

5

6

7



Be sure to wear protective glasses and working gloves during the operation. Ink may get into your eyes depending on the working condition, or hand skin may get rough if you touch the ink.

8

3.1.4 Replacement of the Wiper Unit

1.1

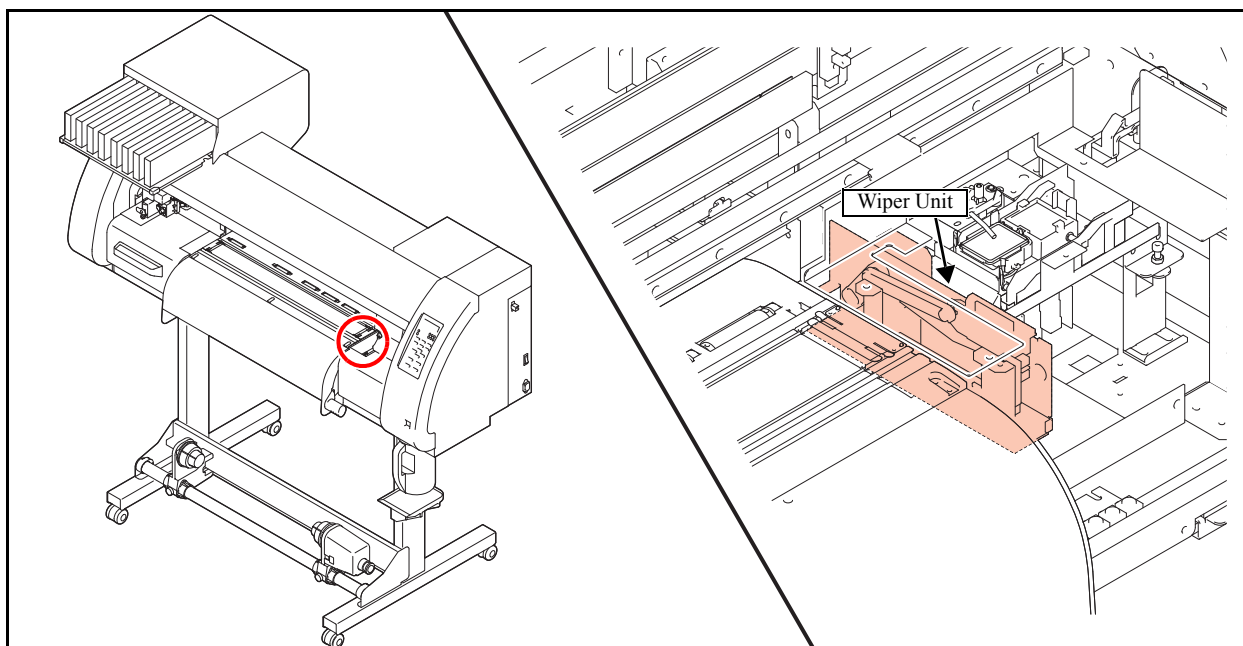

1

2

3

4

5

6

7

8

■ List of replacement procedures

Item	Work operation	Description	Ref.
Covers	1. <input type="checkbox"/> Removal of covers, etc.	Remove the station cover U and C station cover 2.	6.1.1
Wiper Unit	2. <input type="checkbox"/> Removal of the wiper unit.	Remove the wiper unit.	6.4.6
	3. <input type="checkbox"/> Mounting of the wiper unit	Mount the wiper unit. Check whether the wiper moves smoothly while the clearance between the motor pedestal and the wiper drive link is set at 0.5 mm.	6.4.6 4.3.7
	4. <input type="checkbox"/> Adjustment of wiper height	Make adjustment so that, while head height is set low, wiper units are kept parallel and wiper is in contact with the tip of the nozzle by 1.5 mm. Confirm that wiping operation is possible even when the head height is set high.	4.3.4
Adjustment	5. <input type="checkbox"/> Capping adjustment	Carry out [CAPPING] adjustment to confirm that each center of the wiper and the head is aligned.	4.2.5
Check	6. <input type="checkbox"/> Cleaning operation	Check whether each assembly and adjustment has been carried out properly by conducting [WIPER CLEANING] operation.	
Covers	7. <input type="checkbox"/> Mounting of the covers	Mount the covers that have been removed.	6.1.1



Be sure to wear protective glasses and working gloves during the operation.

Ink may get into your eyes depending on the working condition, or hand skin may get rough if you touch the ink.

1

2

3

4

5

6

7

8

Workflow		
3.1 Ink Related Parts	3.2 Cut Head Carriage	3.3 Driving Parts
3.4 Electrical Parts		

3.2.1 Replacement of the Pen Assy and LED Pointer

1.1

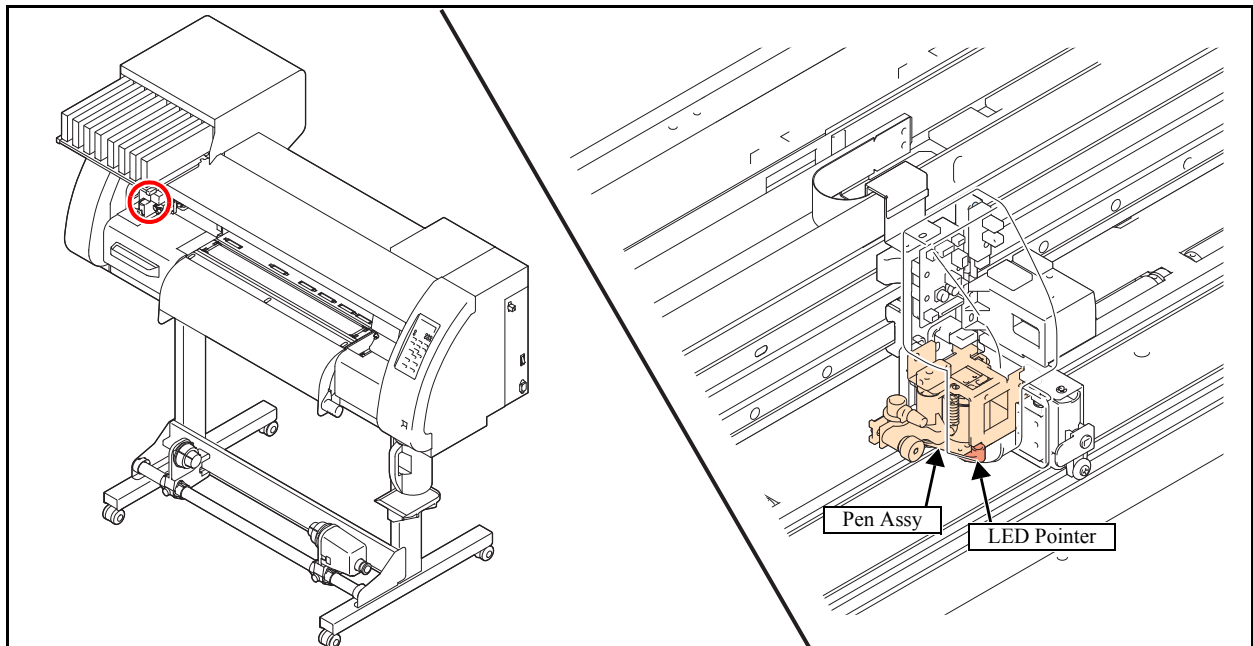

1

2

3

■ List of replacement procedures

Item	Work operation	Description	Ref.
Covers	1. <input type="checkbox"/> Removal of covers, etc.	Remove the C head cover, CY cover F and auto cutter assy. Be sure not to change the direction of the hook of the baffle SP. If its direction is changed, the pen pressure and landing are also changed.	6.1.1
Pen assy, LED pointer	2. <input type="checkbox"/> Removal of the pen assy.	Remove the pen assy.	6.3.1
	3. <input type="checkbox"/> Removal of the LED pointer.	Remove the LED pointer from the pen assy.	
	4. <input type="checkbox"/> Mounting of the LED pointer.	Mount the LED pointer to the pen assy. In installation, pay attention to harness treatment.	
	5. <input type="checkbox"/> Mounting of the pen assy.	Mount the pen assy.	
Adjustment	6. <input type="checkbox"/> Adjustment of the pen stroke	Adjust the pen stroke at 3 ± 0.3 mm.	
	7. <input type="checkbox"/> Adjustment of the mounting location of the cutter	Hold down the clamp lever and adjust the mounting location so that the distance between the auto cutter assy and the platen is set at 8.8 mm.	4.3.2
	8. <input type="checkbox"/> Adjustment of pen pressure and pen landing	Adjust the [PEN PRESSURE] and [LANDING].	4.2.9 4.2.10
	9. <input type="checkbox"/> Adjustment of photo sensor sensitivity	Corrects the output value of the MARK sensor automatically.	4.2.11
	10. <input type="checkbox"/> Adjustment of the position of the photo sensor	Adjust the [#PHOTOsens./POSITION] in [#ADJUST].	4.2.12
Check	11. <input type="checkbox"/> Check each performance	Check the [CUT PATTERN] and cutting position. Carry out "print & cut" online to confirm no misalignment is found.	
Covers	12. <input type="checkbox"/> Mounting of the covers	Mount the covers that have been removed.	6.1.1

4

5

6

7

8

3.2.2 Replacement of the Auto Cutter Assy

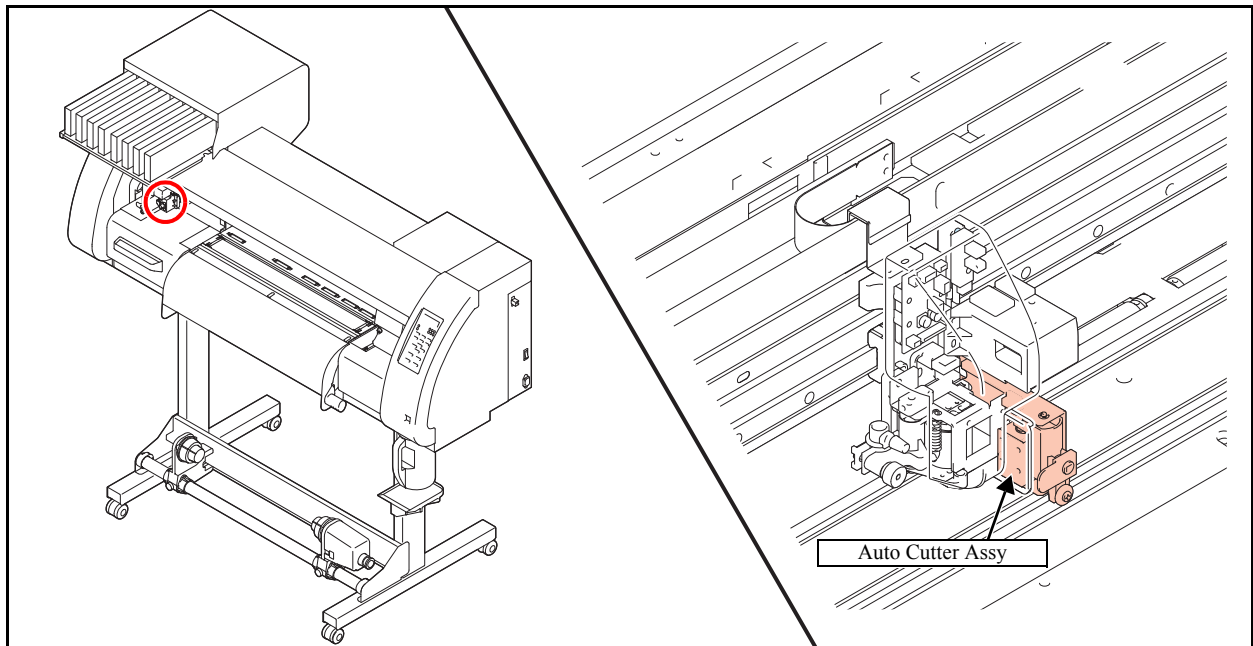

■ List of replacement procedures

Item	Work operation	Description	Ref.
Covers	1. <input type="checkbox"/> Removal of covers, etc.	Remove the C head cover, CY cover F and S guide.	6.1.1
Auto Cutter Assy	2. <input type="checkbox"/> Removal of the auto cutter assy.	Be sure not to change the direction of the hook of the baffle SP. If its direction is changed, the pen pressure and landing are also changed.	6.3.1
	3. <input type="checkbox"/> Mounting of the auto cutter assy.	Mount the auto cutter assy.	
Adjustment	4. <input type="checkbox"/> Adjustment of the mounting location of the cutter	Hold down the clamp lever and adjust the mounting location so that the distance between the auto cutter assy and the platen is set at 8.8 mm. (If necessary, check to see if the magnet catcher and magnet BKT are in contact with each other.)	4.3.2
Check	5. <input type="checkbox"/> Check the performance.	Check the cutting position.	
Covers	6. <input type="checkbox"/> Mounting of the covers	Mount the covers that have been removed. Install the S guide while pushing it to the left.	6.1.1

1

2

3

4

5

6

7

8

3.2.3 Replacement of the Mark Assy

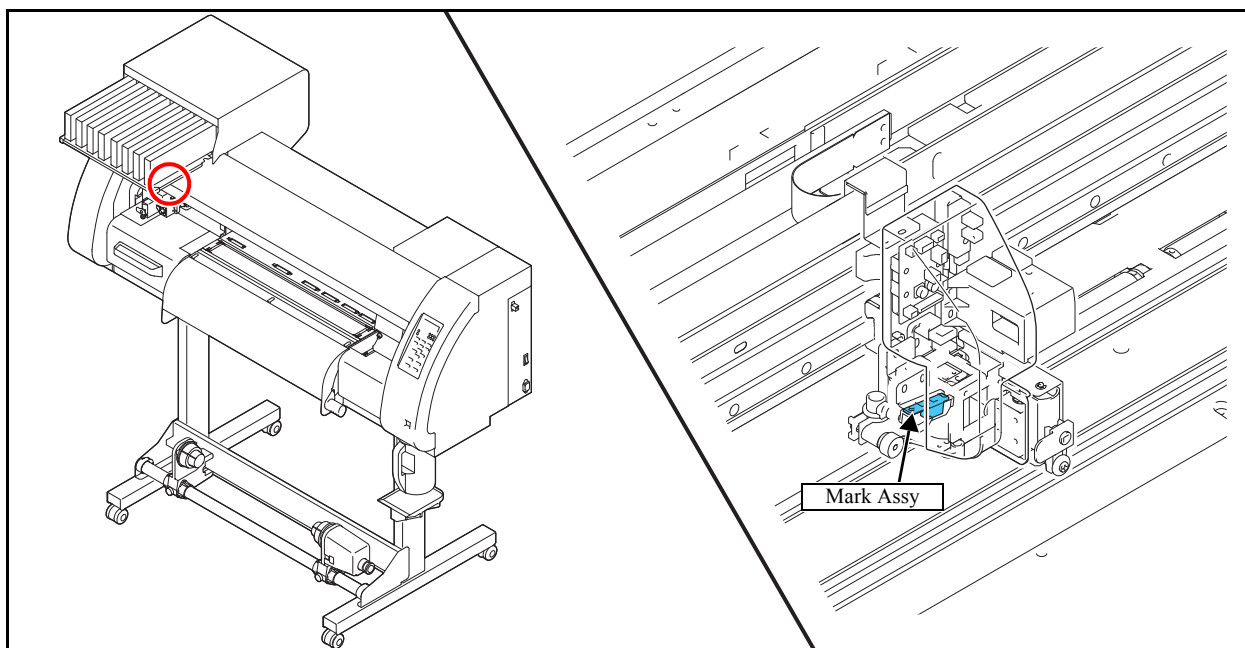

1
2
3
4
5
6
7
8

■ List of replacement procedures

Item	Work operation	Description	Ref.
Covers	1. <input type="checkbox"/> Removal of covers, etc.	Remove the C head cover and CY cover F.	6.1.1
Mark Assy	2. <input type="checkbox"/> Removal of the auto cutter assy and pen assy.	Be sure not to change the direction of the hook of the baffle SP. If its direction is changed, the pen pressure and landing are also changed.	6.3.1
	3. <input type="checkbox"/> Removal of the mark assy.	Remove the mark assy.	6.3.3
	4. <input type="checkbox"/> Mounting of the mark assy.	Mount the mark assy. Set the pressure of all the clamps to Middle, and clamp the assy. Then adjust so that the assy is positioned 2.5 mm above the platen on the right station side.	6.3.3
	5. <input type="checkbox"/> Mounting of the pen assy and auto cutter assy.	Mount the auto cutter assy.	6.3.1
	Adjustment	6. <input type="checkbox"/> Adjustment of the pen stroke.	Adjust so that the pen stroke is 3 ± 0.3 mm as measured from the pen point.
7. <input type="checkbox"/> Adjustment of the mounting location of the cutter.		Hold down the clamp lever and adjust the mounting location so that the distance between the auto cutter assy and the platen is set at 8.8 mm.	4.3.2
8. <input type="checkbox"/> Adjustment of the sensitivity of the photo sensor		Adjust the [#PHOTO SENS./ LV.] in [#ADJUST].	4.2.11
9. <input type="checkbox"/> Adjustment of the position of the photo sensor		Adjust the position of the photo sensor in [#ADJUST].	4.2.12
10. <input type="checkbox"/> Adjustment of pen pressure and pen landing		Adjust the [PEN PRESSURE] and [LANDING].	4.2.9 4.2.10
11. <input type="checkbox"/> Pointer offset			
12. <input type="checkbox"/> Print / Cut			
Check	13. <input type="checkbox"/> Check each performance	Check the [CUT PATTERN] and cutting position. Carry out "print & cut" online to confirm no misalignment is found.	
Covers	14. <input type="checkbox"/> Mounting of the covers	Mount the covers that have been removed. In installation, pay attention to harness treatment.	6.1.1



Once the S guide is removed, reinstall it while pushing the solenoid outward.

1

2

3

4

5

6

7

8

Workflow		
3.1 Ink Related Parts	3.2 Cut Head Carriage	3.3 Driving Parts
3.4 Electrical Parts		

3.3.1 Replacement of the X-axis Motor

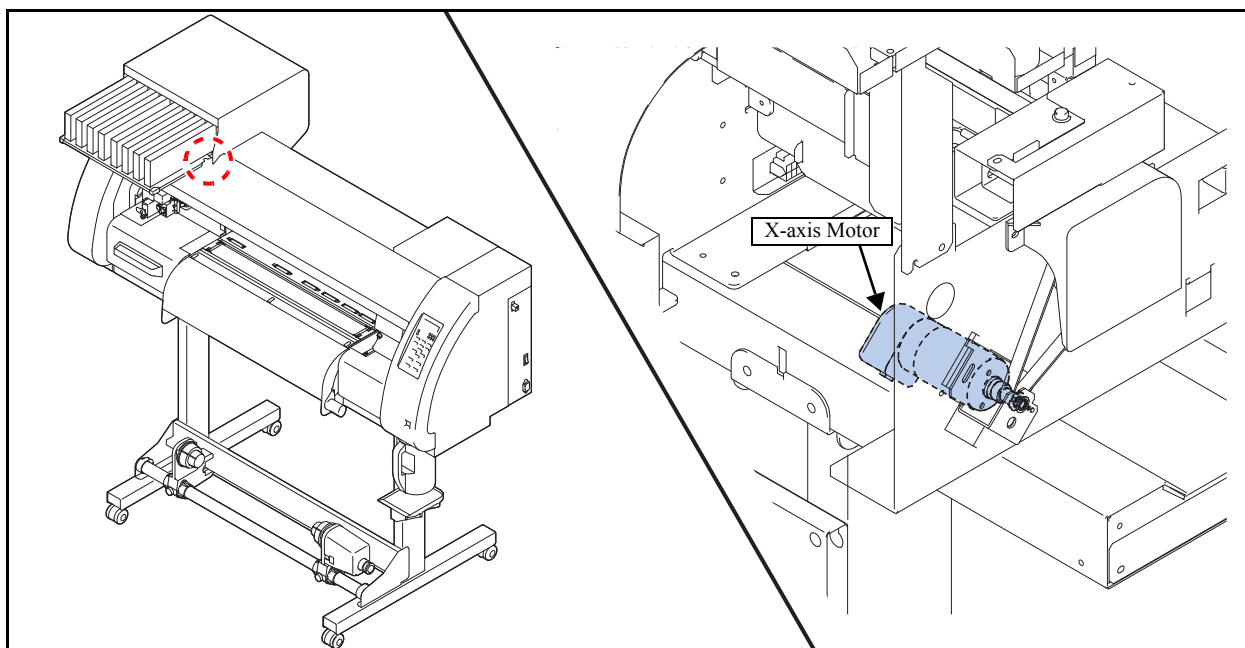

1

2

3

4

5

6

7

8

■ List of replacement procedures

Item	Work operation	Description	Ref.
Covers	1. <input type="checkbox"/> Removal of covers, etc.	Remove the maintenance cover L, cartridge cover and left cover.	6.1.1
X-axis Motor	2. <input type="checkbox"/> Removal of the X-axis motor.	Remove the X-axis motor.	6.4.1
	3. <input type="checkbox"/> Mounting of the X-axis motor.	Mount the X-axis motor.	
Adjustment	4. <input type="checkbox"/> Adjustment of the motor current	If a hunting noise occurs while the motor is being driven, adjust the X-axis motor current.	4.2.14
Covers	5. <input type="checkbox"/> Mounting of the covers	Mount the covers that have been removed.	6.1.1



Be sure to wear protective glasses and working gloves during the operation.
Ink may get into your eyes depending on the working condition, or hand skin may get rough if you touch the ink.

3.3.2 Replacement of the Y-axis Motor

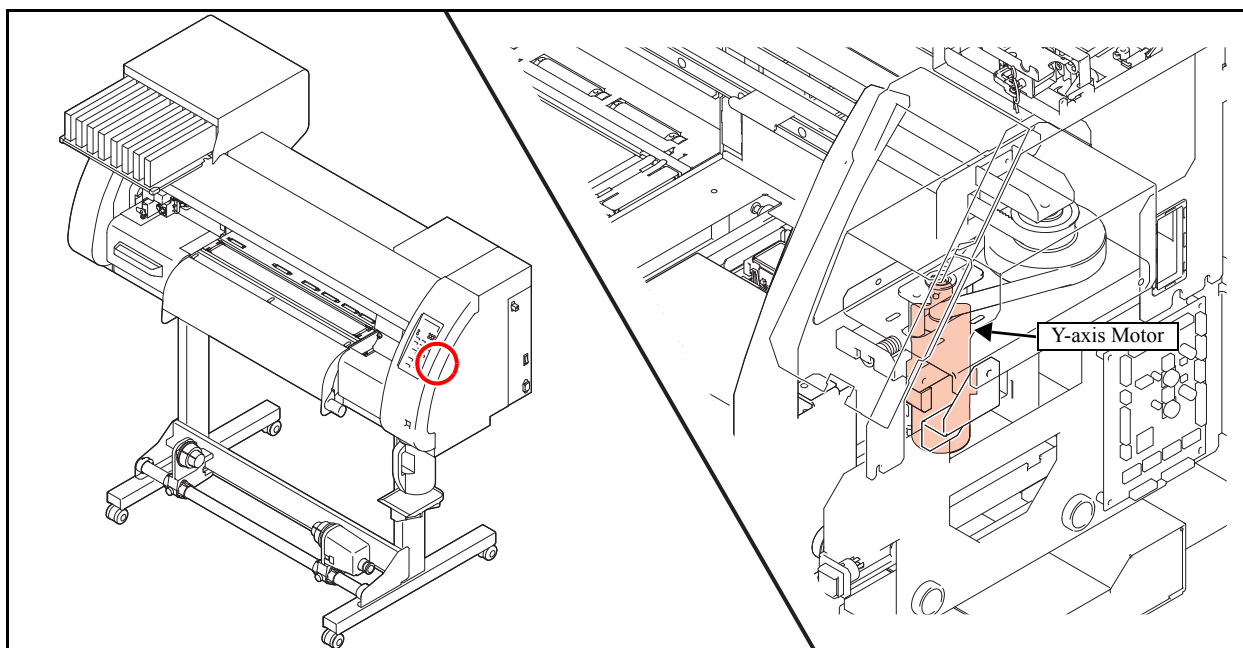

1

2

3

4

5

6

7

8

■ List of replacement procedures

Item	Work operation	Description	Ref.
Covers	1. <input type="checkbox"/> Removal of covers, etc.	Remove the CY cover F, KB cover, right cover and D BKT cover.	6.1.1
Y-axis Motor	2. <input type="checkbox"/> Removal of the Y-axis motor.	Remove the Y-axis motor.	6.4.2
	3. <input type="checkbox"/> Mounting of the Y-axis motor.	Mount the Y-axis motor.	
Adjustment	4. <input type="checkbox"/> Adjustment of the motor current	If a hunting noise occurs while the motor is being driven, adjust the Y-axis motor current.	4.2.14
Covers	5. <input type="checkbox"/> Mounting of the covers	Mount the covers that have been removed.	6.1.1



Be sure to wear protective glasses and working gloves during the operation.
Ink may get into your eyes depending on the working condition, or hand skin may get rough if you touch the ink.

3.3.3 Replacement of the Y Drive Belt

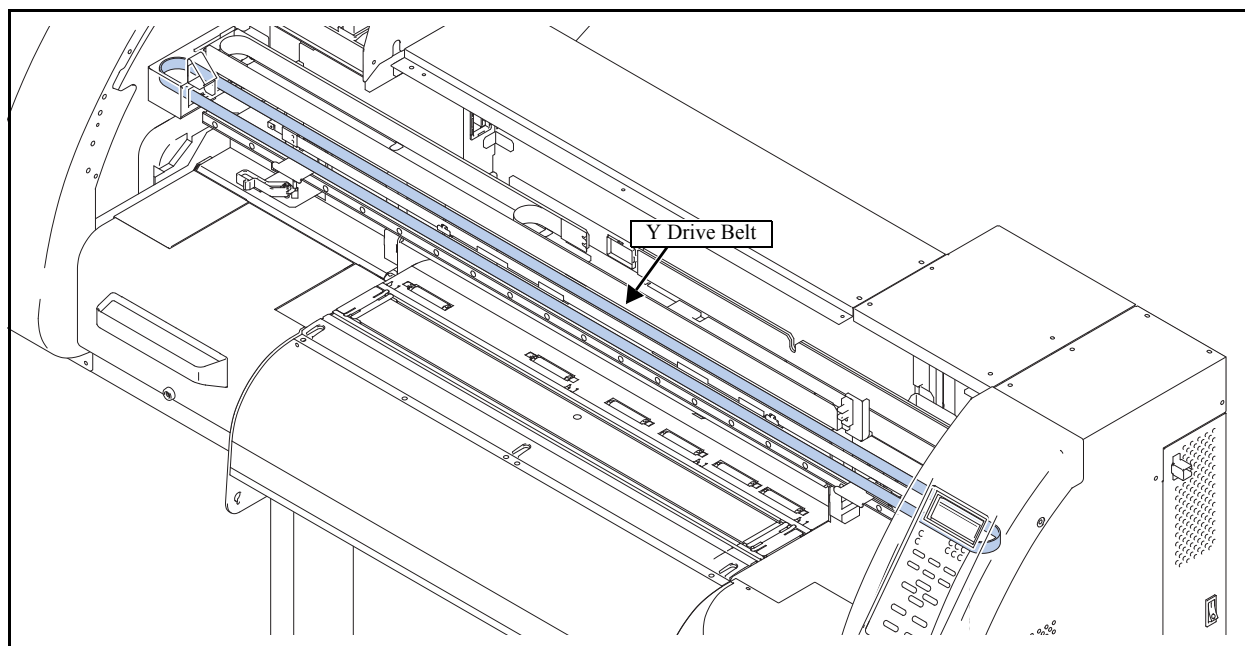

1

2

3

4

5

6

7

8

■ List of replacement procedures

Item	Work operation	Description	Ref.
Covers	1. <input type="checkbox"/> Removal of covers, etc.	Remove the CY cover F, KB cover and right cover.	6.1.1
Y Drive Belt	2. <input type="checkbox"/> Removal of the Y drive belt.	Remove the Y drive belt.	6.4.4
	3. <input type="checkbox"/> Mounting of the Y drive belt.	Mount the Y drive belt.	
Covers	4. <input type="checkbox"/> Mounting of the covers	Mount the covers that have been removed.	6.1.1



Be sure to wear protective glasses and working gloves during the operation. Ink may get into your eyes depending on the working condition, or hand skin may get rough if you touch the ink.

3.3.4 Replacement of the Linear Encoder Scale

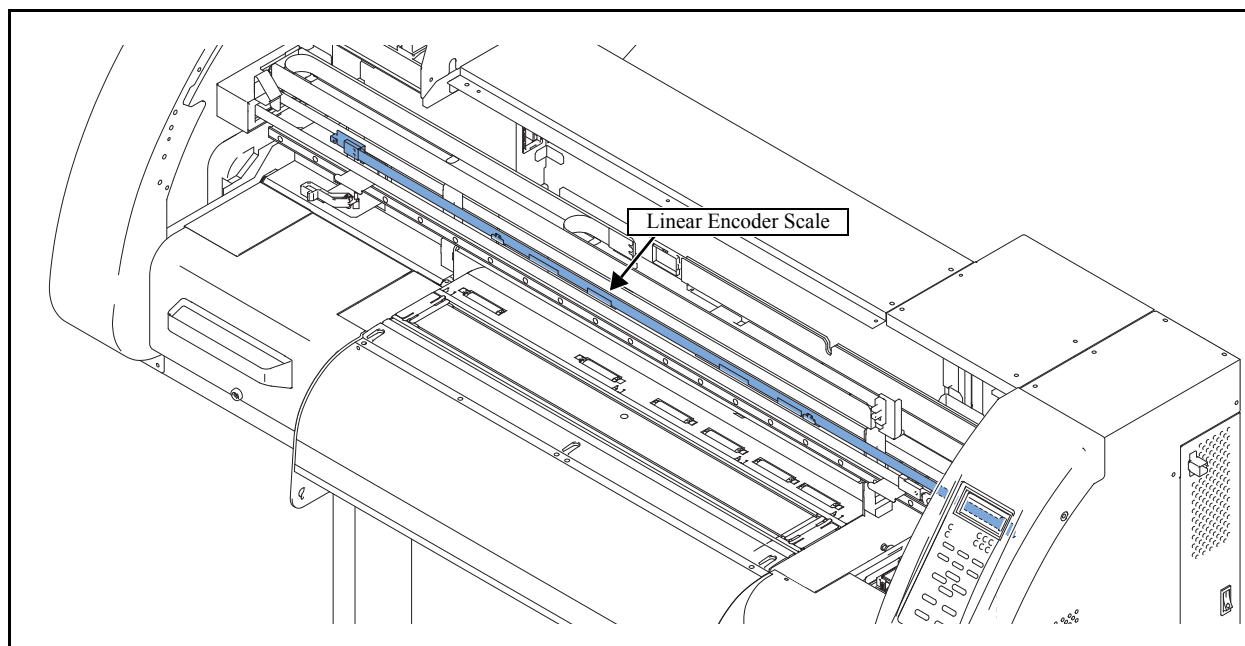

1

2

3

4

5

6

7

8

■ List of replacement procedures

Item	Work operation	Description	Ref.
Covers	1. <input type="checkbox"/> Removal of covers, etc.	Remove the CY cover F and head cover.	6.1.1
Linear Encoder Scale	2. <input type="checkbox"/> Removal of the linear encoder scale.	Remove the linear encoder scale.	6.4.5
	3. <input type="checkbox"/> Removal of the protective film	Peel off the protective film from the encoder.	
	4. <input type="checkbox"/> Mounting of the linear encoder scale.	Mount the linear encoder scale. Pay attention to the location of the encoder PCB assy.	4.3.5 5.1.26
	5. <input type="checkbox"/> Encoder check	Carry out the encoder check to confirm it functions normally.	
Covers	6. <input type="checkbox"/> Mounting of the covers	Mount the covers that have been removed.	6.1.1



Be sure to wear protective glasses and working gloves during the operation.
Ink may get into your eyes depending on the working condition, or hand skin may get rough if you touch the ink.

3.3.5 Replacement the GR Roller Assy

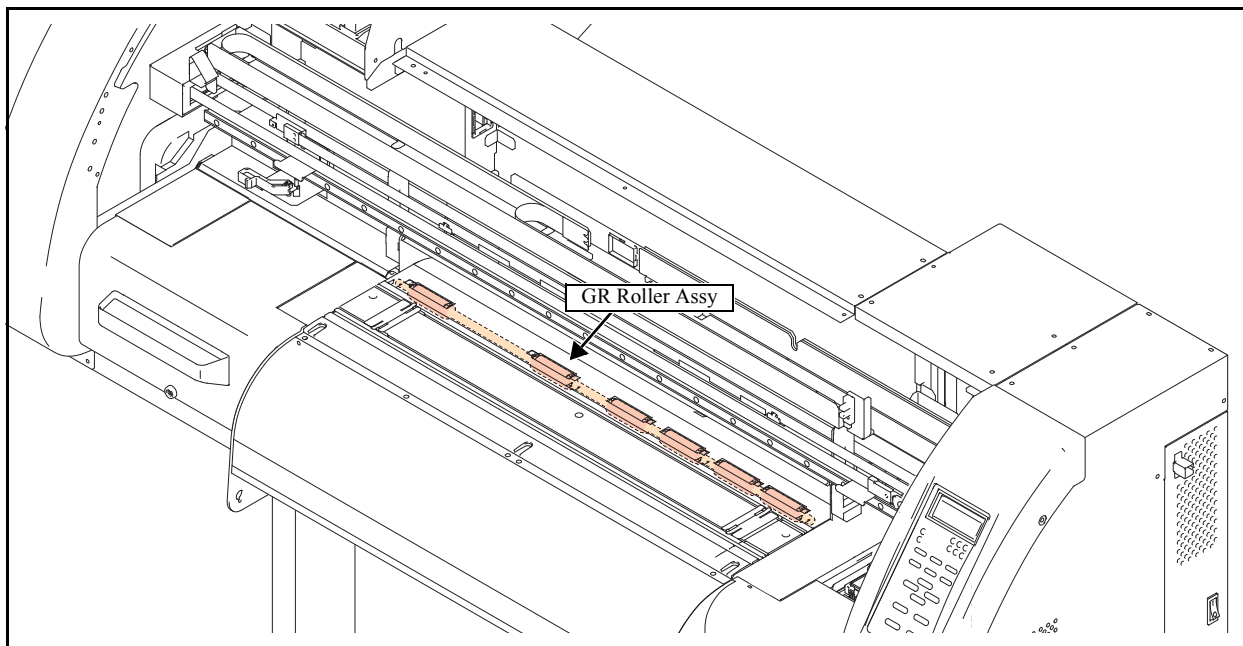

1
2
3
4
5
6
7
8

■ List of replacement procedures

Item	Work operation	Description	Ref.
Covers	1. <input type="checkbox"/> Removal of covers, etc.	Remove the CY cover F, cartridge cover, maintenance cover L, left cover, left station cover, heater connector cover, MS cover 2 and MS cover 1.	6.1.1
GR Roller Assy	2. <input type="checkbox"/> Removal of the GR roller assy.	Remove the GR roller assy.	6.4.7
	3. <input type="checkbox"/> Mounting of the GR roller assy.	Move the BR holder 30 until it reaches the near side and stops, and then mount the GR roller assy.	
Check	4. <input type="checkbox"/> Check on the surface of the platen	When the clearance between the head and the platen is not stabilized and printed image is affected by that, adjust the flatness of the platen.	
Adjustment	5. <input type="checkbox"/> GR/PR adjustment	Make the machine recognize the positional relationship between the grid rollers and pinch rollers.	4.2.13
Covers	6. <input type="checkbox"/> Mounting of the covers	Mount the covers that have been removed. Install all the covers temporarily first and then secure them in order, starting with the one nearest one end. Install the covers while pushing the pre-heater down. (To ensure the space for the pick up chamber and to prevent the covers from rising above the grid rollers)	6.1.1



Be sure to wear protective glasses and working gloves during the operation.
Ink may get into your eyes depending on the working condition, or hand skin may get rough if you touch the ink.

1

2

3

4

5

6

7

8

Workflow		
3.1 Ink Related Parts	3.2 Cut Head Carriage	3.3 Driving Parts
3.4 Electrical Parts		

3.4.1 Replacement of the Main PCB Assy

1.1

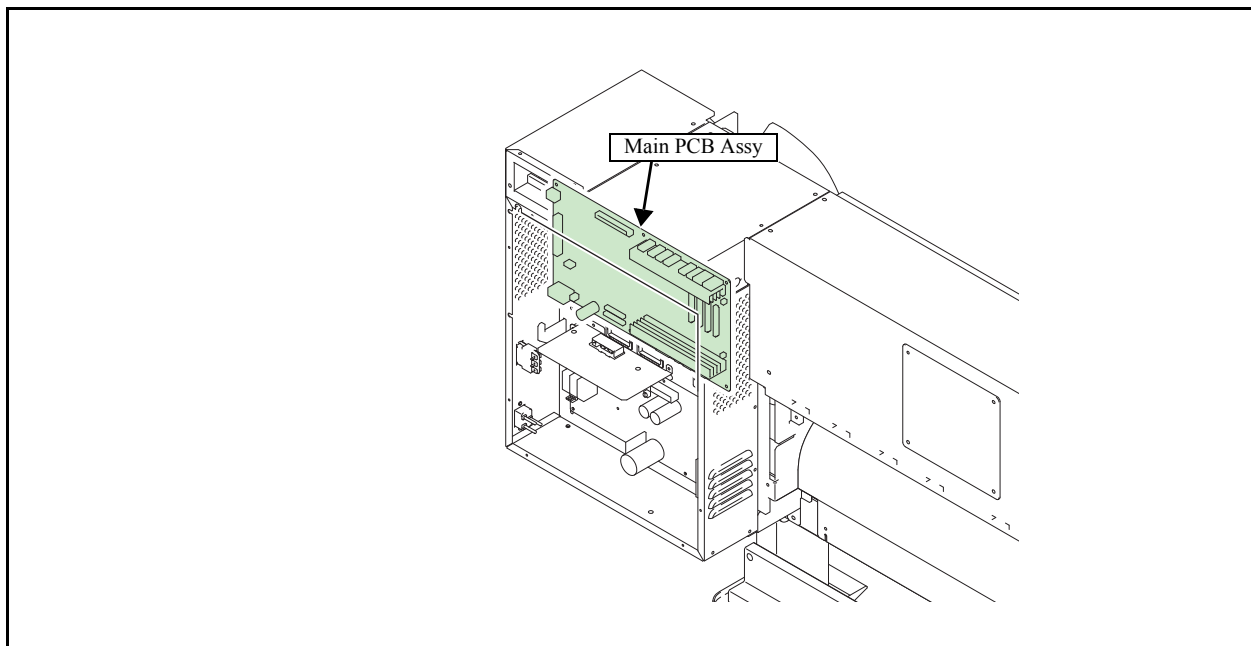

1

2

3

■ List of replacement procedures

Item	Work operation	Description	Ref.
Advance preparation	1. <input type="checkbox"/> Parameter upload	Before the printed-circuit board is replaced, upload its parameter to the PC.	
Covers	2. <input type="checkbox"/> Removal of covers, etc.	Remove the electrical box cover.	6.1.1
Main PCB Assy	3. <input type="checkbox"/> Removal of the main PCB Assy.	Remove the main PCB Assy.	6.4.7
	4. <input type="checkbox"/> Mounting of the main PCB Assy.	Mount the main PCB Assy.	
Check	5. <input type="checkbox"/> Parameter download	Download the parameter which has been uploaded in the operation "1".	
	6. <input type="checkbox"/> Adjustment of the motor current	Adjust motor current in case a hunting noise occurs.	4.2.14
Covers	7. <input type="checkbox"/> Mounting of the cover.	Mount the cover that have been removed.	6.1.1

4

5

6

7

8

1

2

3

Adjustment Items

**4.1
Operation Matrix**

**4.2
Adjustment Function**

**4.3
Mechanical Adjustment**

4

5

6

7

8

4.1.1 Matrix of Operations and Adjustments

When dealing with malfunctions, see “Troubleshooting”.

Adjustment item	Uploading of Parameters	Downloading of Parameters	Adjustment of the motor current (4.2.14)	Adjustment of the pen stroke (4.2.11)	Adjustment of the pen pressure (4.2.9)	Adjustment of the pen landing (4.2.10)	Adjustment of the cutter landing	Distance accuracy/Right angle adjustment (4.2.8)	Adjusting the location of mark sensor (photo sensor) (4.3.1)	Adjusting the sensitivity of mark sensor (photo sensor) (4.2.11)	Adjusting the position of mark sensor (4.2.12)	Auto cutter blade position adjustment (4.3.2)	Adjustment of output voltage	Sensor test (5.1.14)	Slant adjustment (4.2.1)	Drop position adjustment (4.2.2)	Adjustment of Capping	Registration of part replacement (4.2.19)	Adjustment of the wiper height (4.3.4)
Work contents																			
Firmware update*1, *2					①	②		③		④	⑤								
Pen assy removal or replacement				①	②	③	④				⑤								
Auto cutter assy removal or replacement												①							
Mark assy removal or replacement									①	②	③								
Head PCB assy replacement										①									
Main PCB replacement	① *1	②	③		④	⑤				⑥									
X-axis motor assy removal or replacement			①																
Y-axis motor assy removal or replacement			①																
Power supply unit													①						
Head removal or replacement															①	②			
Cap replacement																	①	②	
Pump replacement																		①	
Damper																		①	
Auto cutter blade removal or replacement												①							
Wiper assy removal or replacement																			①

*1 Be sure to make adjustment before replacing the main PCB assy.

*2 See “Chapter 4, Technical Information” of “Service Documents”.

1
2
3
4
5
6
7
8

1

2

3

Adjustment Items

4.1
Operation Matrix

4.2
Adjustment Function

4.3
Mechanical Adjustment

4

5

6

7

8

4.2.1 [HEAD ADJUST] SLANT ADJUST

■ Function

Makes mechanical adjustment of print head slant while checking the pattern. Make this adjustment when replacing the head.

■ Procedure

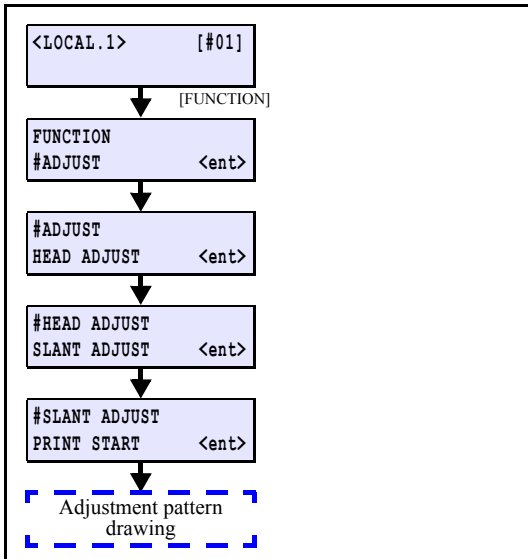

1. Select [SLANT ADJUST] from the operation menu to execute adjustment pattern drawing.
2. Move the head over the platen using the JOG key.

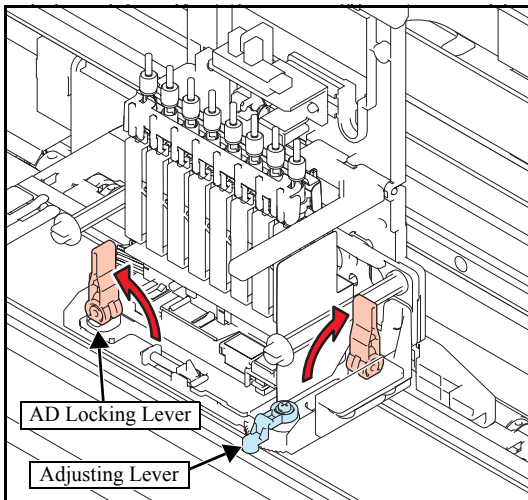

3. Lift up the two AD locking levers to release the lock, and move the adjusting lever to adjust the slant of the head.

 Movement per one scale of the adjusting lever: 40 μm

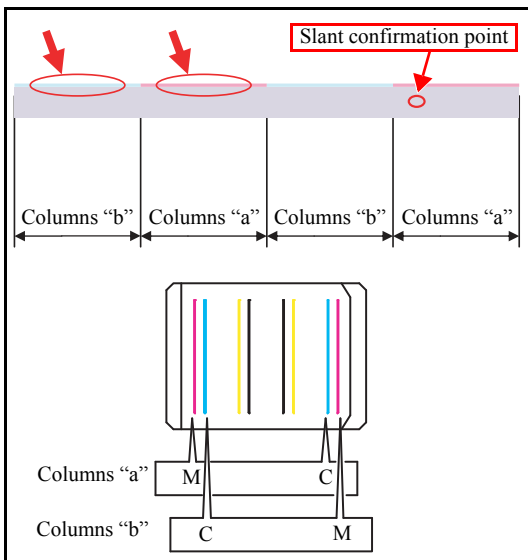

4. Carry out the slant adjustment through the following procedures. As shown in the diagram on the left, patterns of columns "a" and columns "b" are printed alternately at a pitch width of approximately 100 mm. The discrimination between columns "a" and columns "b" is performed by the magenta and cyan strips (indicated by the thick red arrows in the diagram on the left) printed over the respective patterns at the top of head 1. These strips indicate that magenta is column "a" and cyan is column "b".

1

2

3

4

5

6

7

8

4.2.1 [HEAD ADJUST] SLANT ADJUST

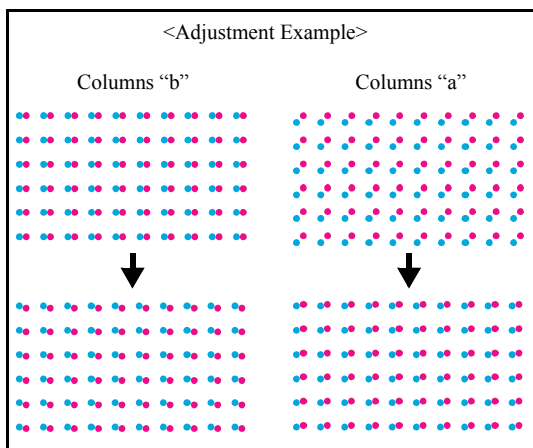
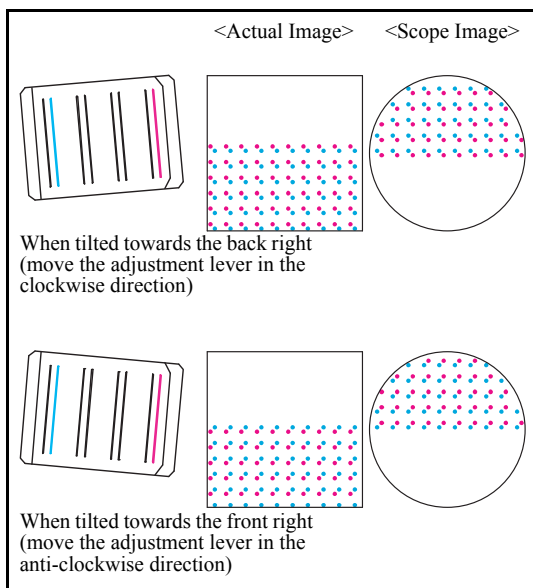

① Check the slant of each column.

For the columns "b", the relationship between the points of impact and the slant of the head is as shown in the diagram on the left.

For the columns "a", the pattern is reversed.

② Perform an averaging adjustment.

The standard color for each column is M for columns "a" and c for columns "b".

Move the adjustment lever and adjust the slant.

In the diagram on the left, the columns "b" are aligned while the columns "a" are misaligned. In this case, move "b" columns slightly so that the degrees of scattering of "a" and "b" columns are equal. (=Intermediate adjustment)

1

2

3

4

5

6

7

8

4.2.2 [HEAD ADJUST] DROP.POS ADJUST

Function

Adjusts the location of impact points during to-and-fro movement of printing operation. Provides a baseline value for user compensation value.

Is used when modifying ink type or making strict adjustment during installation.

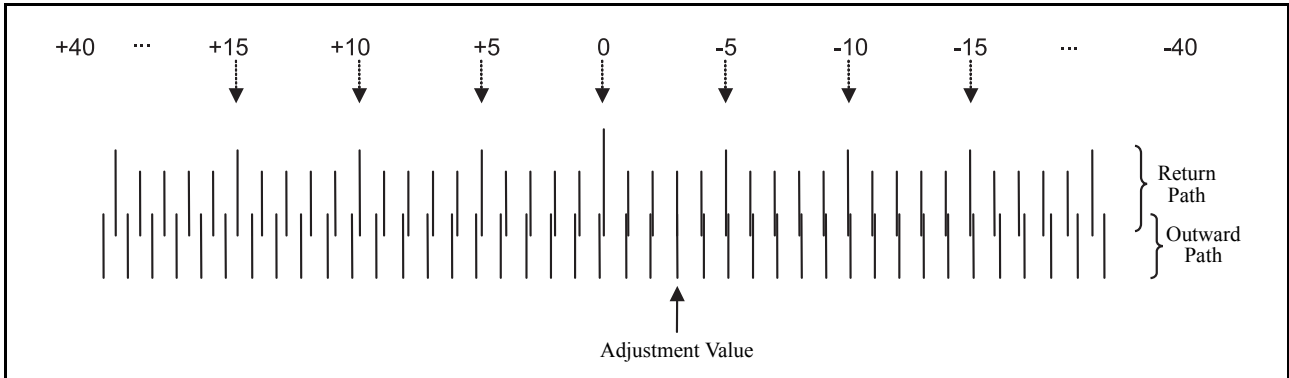

1

2

3

4

5

6

7

8

Procedure

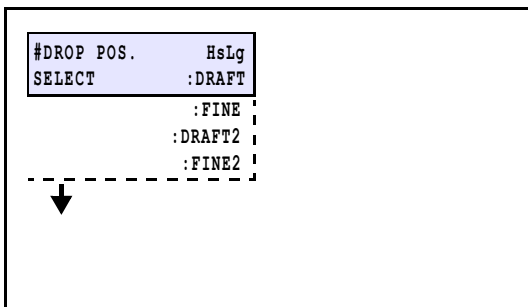
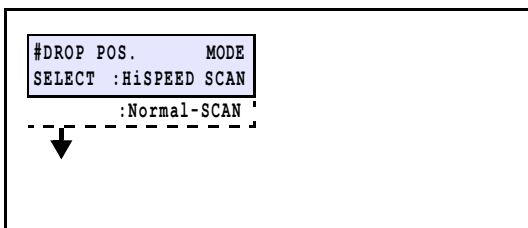
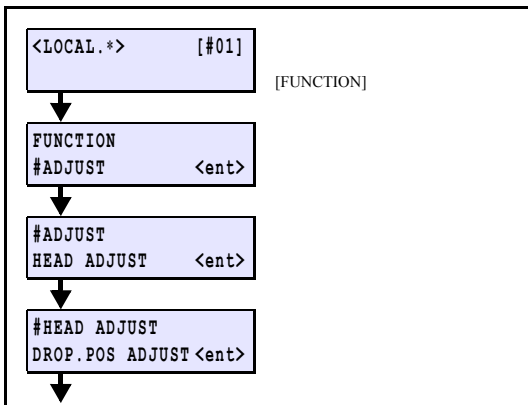

1. Select "DROP POS." from the operation menu.



Make sure to check the [HEAD HEIGHT]. Head height is adjusted at [Thin] before shipment. Since only an alternative adjustment value is prepared, the baseline is also adjusted at [Thick] by adjusting at [Thick].

2. Select a scan speed to be used as a standard.

Selection item: Normal/HiSPEED (*Initial setting: HiSPEED)



The same adjusted value is applied to both scan speeds. Therefore, there is no need of making adjustment for each speed. (Make adjustment only for one speed.)

[▲]/[▼]: Switches scan speed.

[ENTER]: Finalizes (To Next)

3. Select a resolution to be used as a standard.

Selection item: DRAFT (540dpi)/ FINE (720dpi)

[▲]/[▼]: Switches Resolution.

[ENTER]: Finalizes (To Next)



Adjusts all of DRAFT, FINE, DRAFT2, and FINE2.

4.2.2 [HEAD ADJUST] DROP.POS ADJUST

1.0

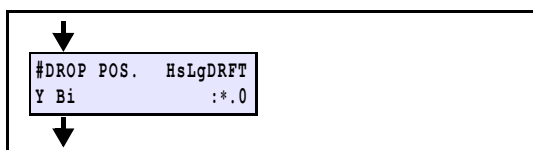
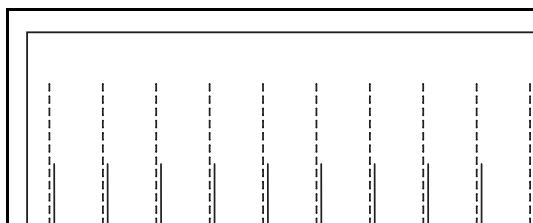
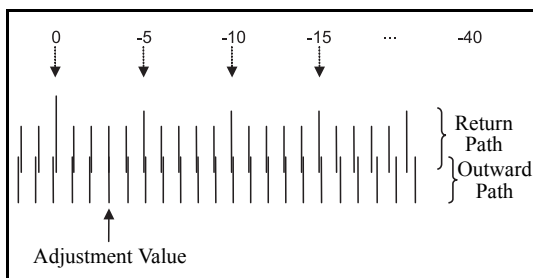
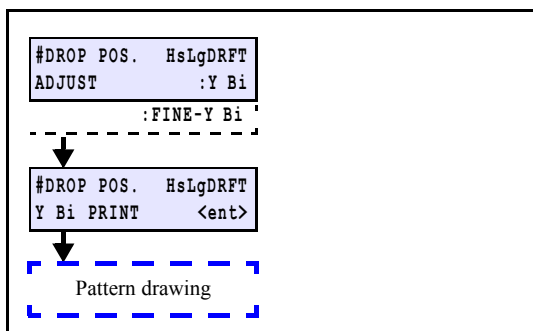

4. Carry out printing in order of [Y Bi] and [FINE-Y Bi].

After adjusting the Y return (Y Bi), perform fine adjustment of the fine Y return (FINE-Y Bi).

[▲]/[▼]: Switches

5. Check the pattern.

■ Y Bi

Check the overlapping parts of the patterns of the outward and return paths.

■ FINE-Y Bi

Only the raw D is used for drawing the pattern. Adjust the pattern until the two lines overlap, using the scope.

Adjusting value: -50.0 to 50.0 dot (unit: 0.1 dot)

6. Enter the adjustment value.

 When this adjustment has been made, previously adjusted value of [DROP.POScorrect] is cleared.

1

2

3

4

5

6

7

8

4.2.3 EDGE ADJUST

1.1

■ Function

Adjust the width of the each dead space of the right and left ends of the media.

Since media detection is carried out by the pinch roller, make adjustment so that location of patterns is inside both ends of the pinch roller, which is the usable plot area.

Is used when the system parameter has been initialized or the (plot areas at both ends) are not in the right place.

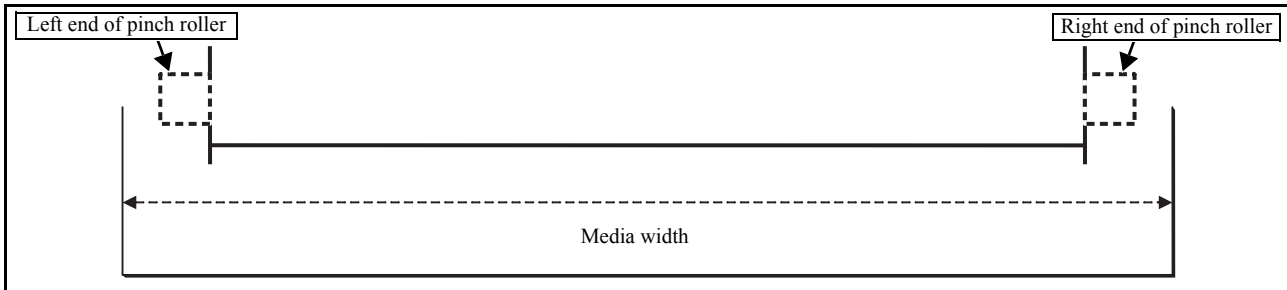

■ Procedure

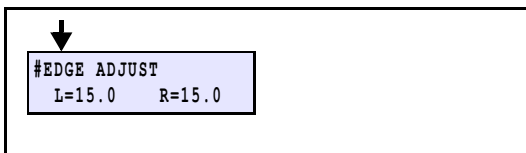
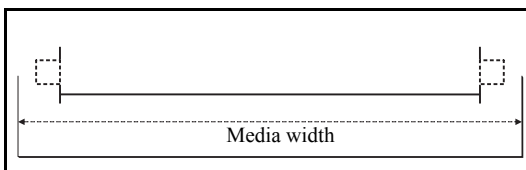
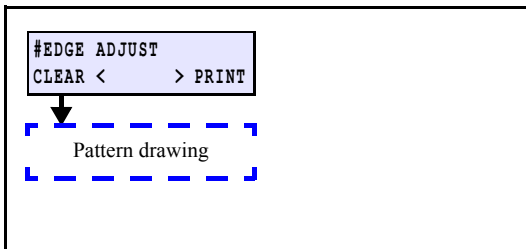
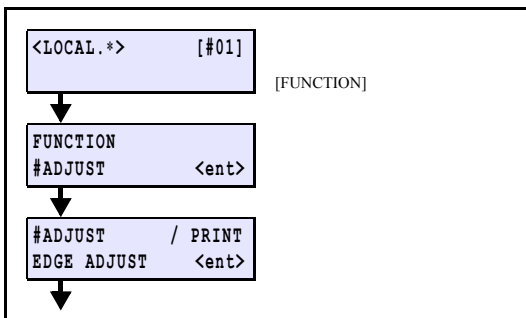

1. Select [EDGE ADJUST] from the operation menu.



Make adjustment with [EXPANDS] of [COMMON SETUP] turned OFF.

2. Draw an adjustment pattern.

[◀]: Set adjust values of L and R to default (0.0 mm).

[▶]: Execute media width detection to draw an adjustment pattern.

[▲]: To the screen for adjustment (Without drawing)

3. Check the adjustment pattern.

4. Enter the adjustment value.

For adjustment, input actual values obtained by measuring from the inner end of the pinch roller to the pattern.

Adjusting value: 0.0 to 35.0 mm (unit: 0.1 mm)

(Use the inside of pinch roller as a positive (+). The backlash of the pinch roller may produce an error of approx. ± 0.5 mm.

[▲]/[▼]: Changes adjustment values.

[END]: Cancellation of input



- The set value is saved in the system parameter No.2 R GRIP and No.3 L GRIP.

4.2.4 MEDIA COMP.2

1.0

■ Function

Compensates basic feeding amount of media. (Provides a baseline value for user compensation value.)

Is used to adjust the media feed amount when the parameter has been initialized or user compensation value is too large.

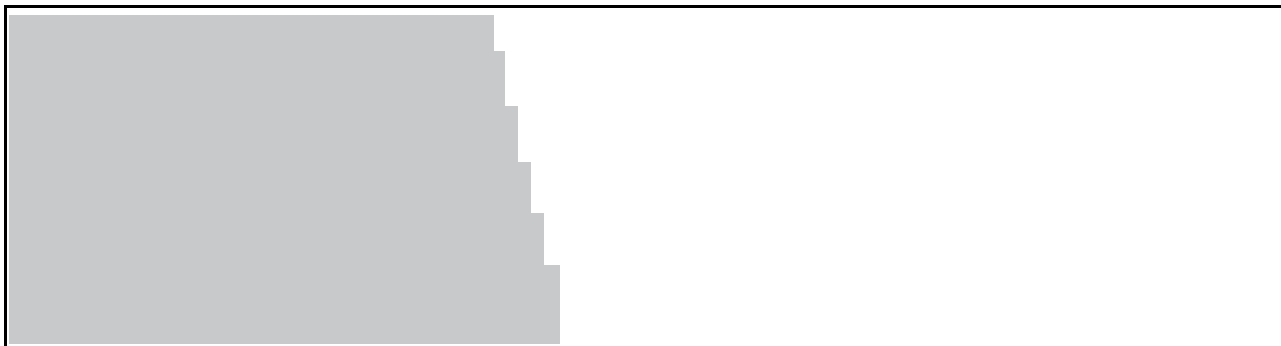

1

2

3

4

5

6

7

8

■ Procedure

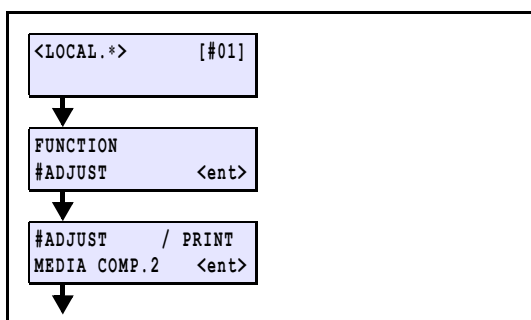

1. Select [MEDIA COMP.2] from the operation menu.

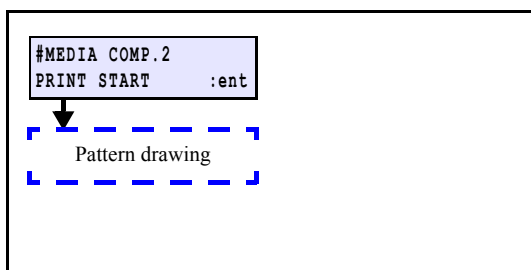

2. Draw an adjustment pattern.

[ENTER]: Executes drawing.

[▶]: To the screen for adjustment
(Without drawing)

[END]: Completes drawing and inputs compensation value.



Patterns are plotted repeatedly.
(Click [END] to end plotting.)

3. Check the adjustment pattern.

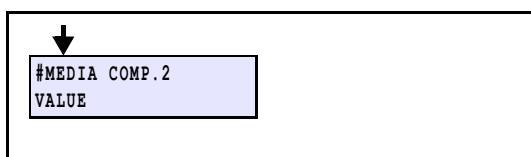
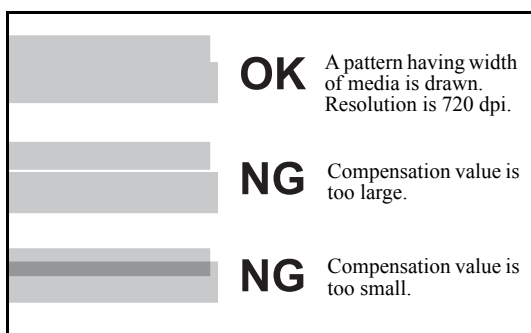

4. Enter the compensation value.

Compensation value: -500 to 500

[▲]/[▼]: Changes adjustment values.

[END]: Cancellation of input



In actual feeding amount compensation, compensation value for each media set in the SETUP function are added to this compensation value.

4.2.5 CAPPING

■ Outline

Adjusts the location for capping and wiper. Adjusted value is saved in the system parameter.
Basically, it is not necessary to make adjustment even when cap (and the like) has been replaced.

■ Adjustment procedure

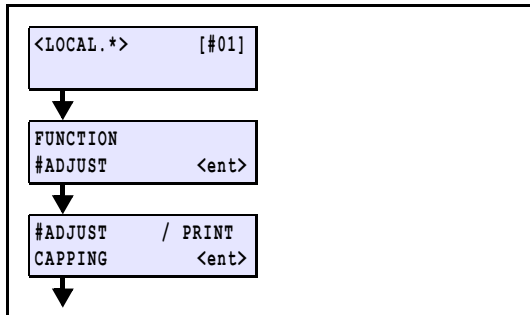

1. Select [CAPPING] from the operation menu.

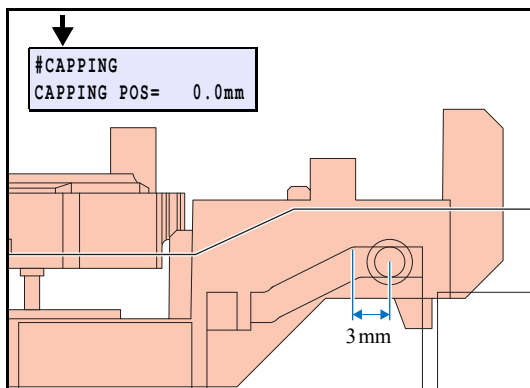

2. Make adjustment so that the cap slider is located at 3 mm to the right from the uppermost point it has reached on the cap base.

[◀]/[▶]: Horizontally shifts the cap.
[ENTER]: Finalizes (To Next)

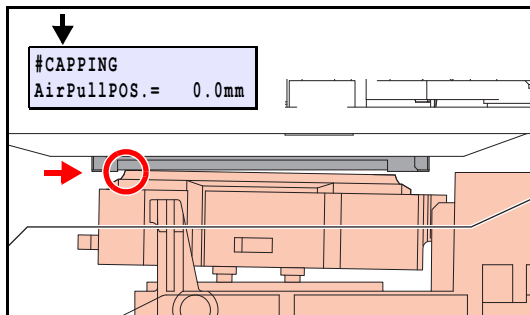

3. Make adjustment so that the head is located exactly at the point where the head is in contact with rubber portion (left end) of the cap head.

[▲]/[▼]: Shifts the cap.
[ENTER]: Finalizes (To Next)

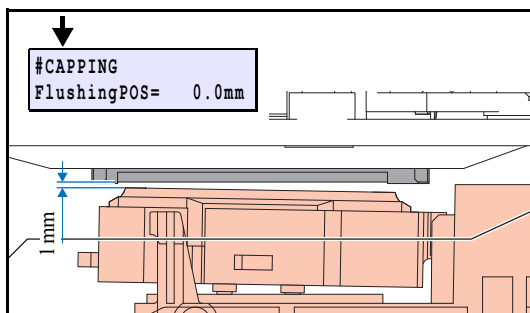

4. Make adjustment so that the clearance between the head and left end of the cap is set at 1 mm.

[◀]/[▶]: Shifts the cap.
[ENTER]: Finalizes (To Next)

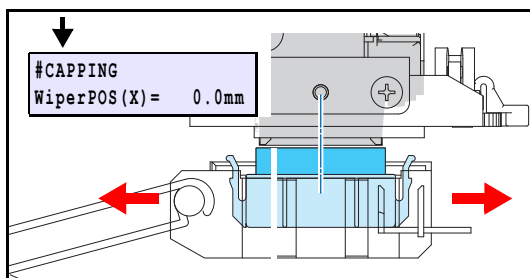

5. Make adjustment so that each center of the wiper and the head coincides.

[◀]/[▶]: Horizontally shifts the wiper.
[ENTER]: Finalizes
[END]: Completes

4.2.6 HEAD ID

■ Function

Head ID input of this machine is automatically executed by the printer side.

The head memory PCB Assy is mounted on the head unit Assy, and the ID information is written in the head memory PCB Assy.



Head ID is for compensating differences of discharge amount of ink among each head. A label on which a compensation value (ID: in 24 digits) is written is attached on a head at the factory shipment. Storing this ID in the Parameter of this machine makes print quality constant.



Manual input of the ID information is required in the following cases.

- In a case that the ID information is not stored in the head memory PCB Assy: [HEAD ID Un input] is displayed on the panel (at power on)
- Pay attention when replacing PCB, because even if the head ID is not identical to the ID information in the memory PCB Assy (a PCB of another head is placed, for example), the error is not displayed on the panel. Manual input of ID is recommended if there is a doubt on the agreement between the ID of a head and the ID information in the memory PCB Assy.

■ Procedure (In case of manual input)

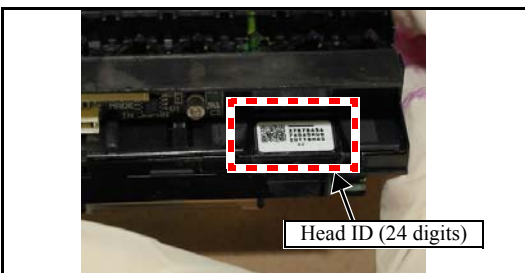

1. Prepare a head ID.

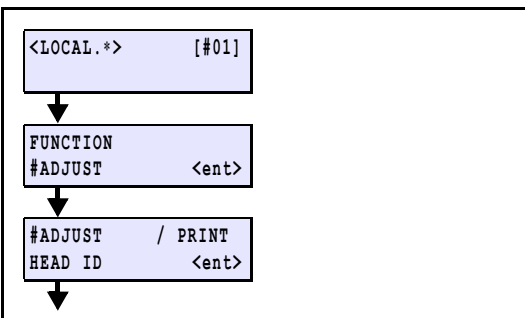

2. Select [HEAD ID] from the operation menu.

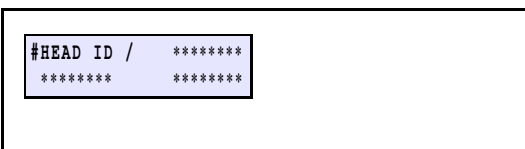

3. Enter the head ID.

[ENTER]: Determines and saves.



If the ID, which has been input, is incorrect, operation error (ERROR 30) is displayed.

1

2

3

4

5

6

7

8

4.2.7 HEAD WASH

■ Function

Cleans the ink channels inside the head, damper and tube.

When modifying ink type or ink set, empties the ink out of the channel and cleans the inside using the washing liquid.



- During the cleaning sequence, the cartridge sensor in the printer monitors the insertion and removal of each cartridge. When the sensor detects the cartridge specified on the screen (or when the sensor detects no cartridge), the printer automatically carries out absorbing and discharging operations (The ink suction pump motor is activated). Note that the washing liquid cartridge will be recognized as normal even when the cartridge sensor fails to read IC chip information, because the cartridge is not equipped with the IC chip.
- As non-filling state remains after the completion of cleaning, the Initial Filling or filling of corresponding head is required.

■ Procedure

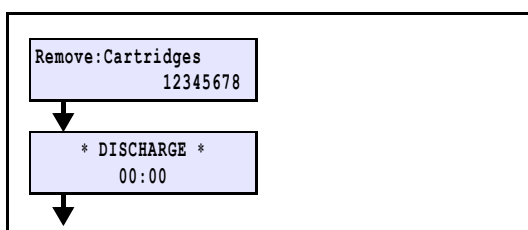
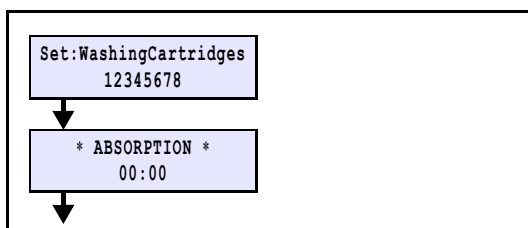
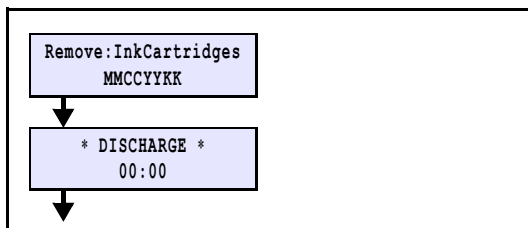
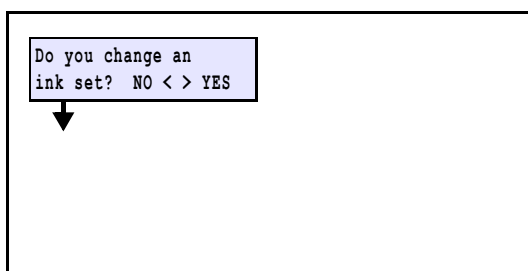
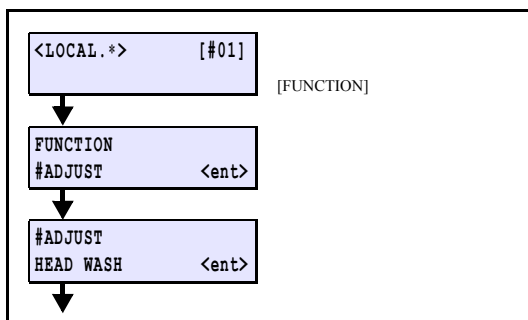

1. Select [HEAD WASH] from the operation menu.

2. During the initial filling after cleaning the head, select “Yes” if you change the ink set.
(The ink set can be changed only at the factory shipment, because change of the coupler is also needed.)

[◀]: Head wash (normal)

[▶]: Head wash that accompanies ink-set change.

3. Remove all the ink cartridges and then discharge the ink inside.
Carry out the discharge after the confirmation of display when a waste ink tank warning occurs.

4. Insert the washing-liquid cartridges into all the slots, clean the inside of the tube, and then carry out head vibration.

5. Remove all the washing-liquid cartridges and then discharge the liquid inside.

1

2

3

4

5

6

7

8

4.2.7 HEAD WASH

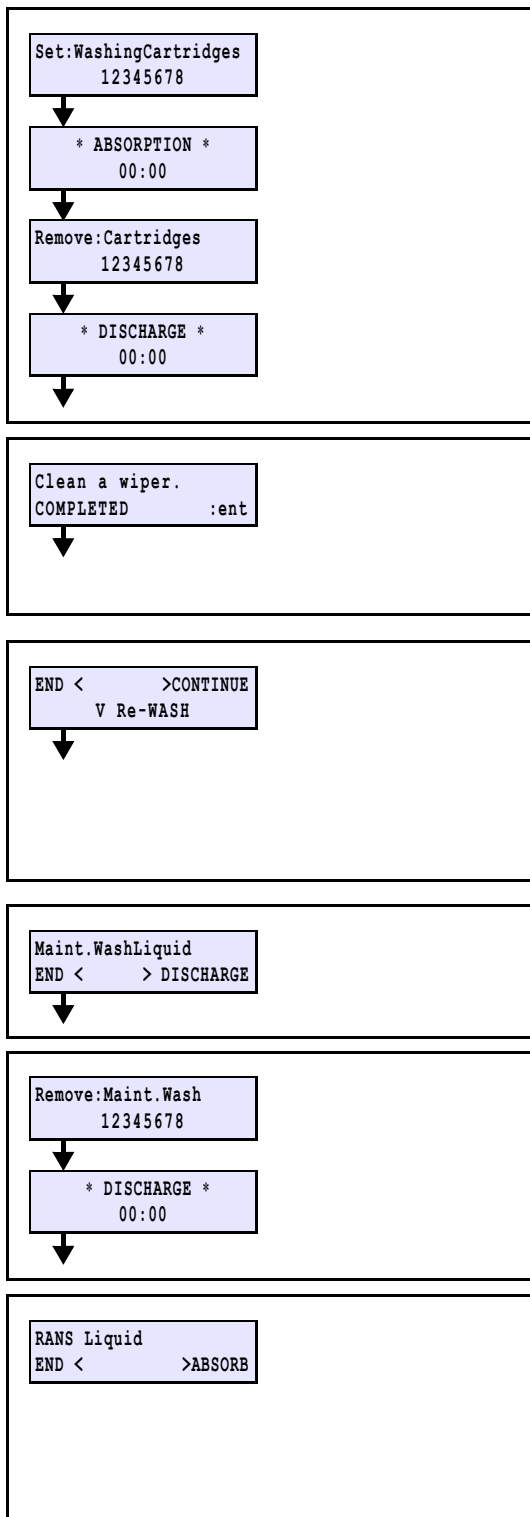

6. Clean inside the ink channels using washing liquid one more time.

7. "Cap OFF" is carried out automatically and the print head carriages move to the maintenance position. Then "Wiper ON" is carried out automatically and the wipers are cleaned.

[ENTER]: To the next operation

8. Select the next operation.

[◀]: To the screen displaying the next operation selection. (Step 9.)

[▶]: Filling of the transportation liquid (Only at the factory shipment)

[▼]: Additional cleaning (Step 4.)

9. Select the next operation.

[◀]: Head-wash completed (in this sequence)

[▶]: Discharge of the maintenance washing liquid (To the next operation)

10. Remove the maintenance washing liquid cartridges and discharge the liquid inside.

11. Select [END] to end the operation.

[◀]: Head-wash completed (in this sequence)

[▶]: Discharge of the maintenance washing liquid (Only at the factory shipment)

1

2

3

4

5

6

7

8

4.2.8 500mm SQUARE

1.1

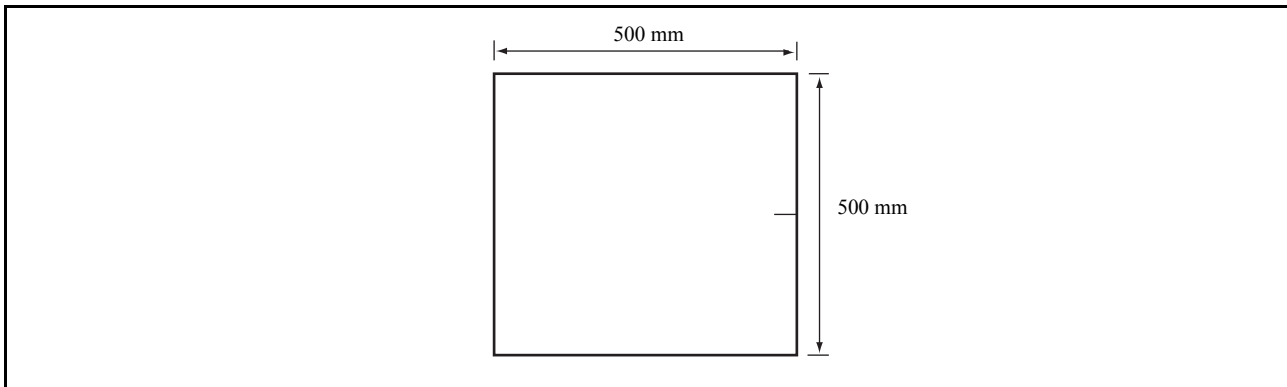

■ Function

Adjusts the working distance in the X direction in cutting operation.

Is used to check the distance when the parameter has been initialized, when the position aberration of the feed direction has occurred during cutting operation, or when plotting cannot be carried out in accordance with the specified distance.

■ Procedure

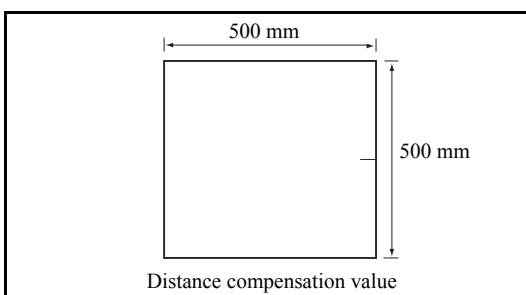
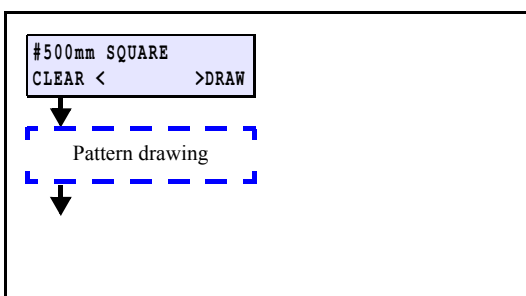
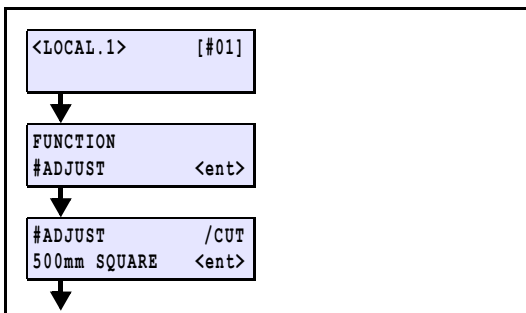
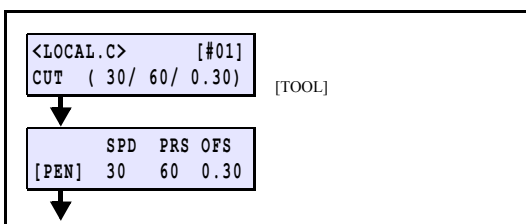

1. Set media, and attach the supplied pen to the cut head carriage.

2. Press [TOOL] with CUT MODE <Local> to set to [PEN].

3. Select [500mm SQUARE] from the operation menu.

4. Plot a square pattern.

[◀]: Compensation value is cleared.

[▶]: Pattern drawing

[▲]: To the screen for compensating

*If there is not enough space for the plotting on the media, Step 6 is displayed and the plotting is not performed.

5. Measure the length of X (feed direction), and work out a compensation value.

Equation: Measured value (mm) - 500 (mm)

= Compensation value (Input value)

*unit: 0.1 (mm)



Y (scan direction) can be displayed on LCD, but it cannot be input.

4.2.8 500mm SQUARE

1.1

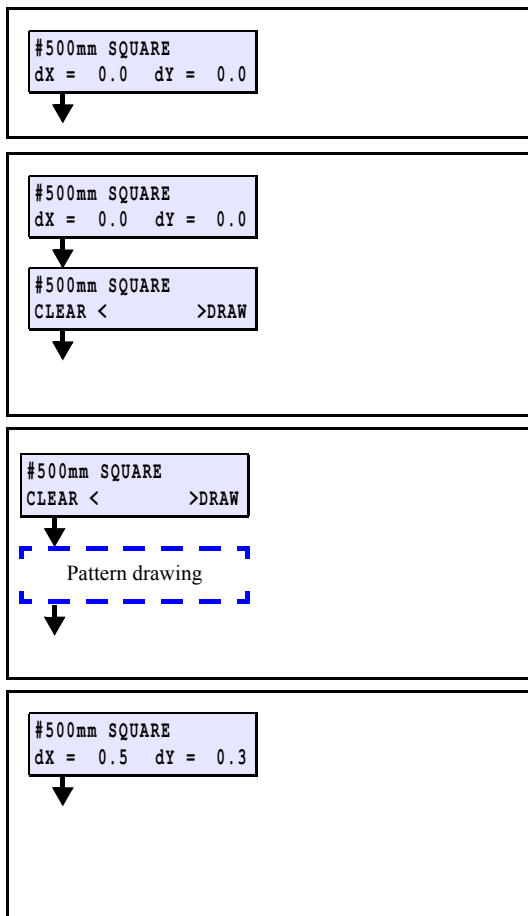

6. Compare a compensation value gained by an actual measurement with the one displayed by LCD. If these values are not the same, enter a compensation value through the following procedures.

7. Press [ENTER] twice, then press [◀] to clear the system parameter values (No.0, 1, 2).

[ENTER]: Back to the previous screen.

[◀]: Compensation value is cleared.

[▶]: Pattern drawing

[▲]: To the screen for compensating

8. Plot a square again, and measure the lengths.

*If there is not enough space for the plotting on the media, Step 6 is displayed and the plotting is not performed.

[◀]:

[▶]: Pattern drawing

[▲]: To the compensation screen

9. Input the compensation value of X (feed direction).

Equation: Measured value (mm) - 500 (mm)

= Compensation value (Input value)

*unit: 0.1 (mm)

[▲]/[▼]: Modifies the compensation value.

[ENTER]: Finalizes

1

2

3

4

5

6

7

8

4.2.9 PEN PRESSURE

■ Function

- Makes adjustment so that pen (cut) pressure can be controlled as / specified).
The adjusted values are registered as system parameters (No.13, 14, 15, 16, 17 and 18).
- Make the adjustment for the following six values:
0g, 30g, 60g, 100g, 200g, 350g

■ Procedure

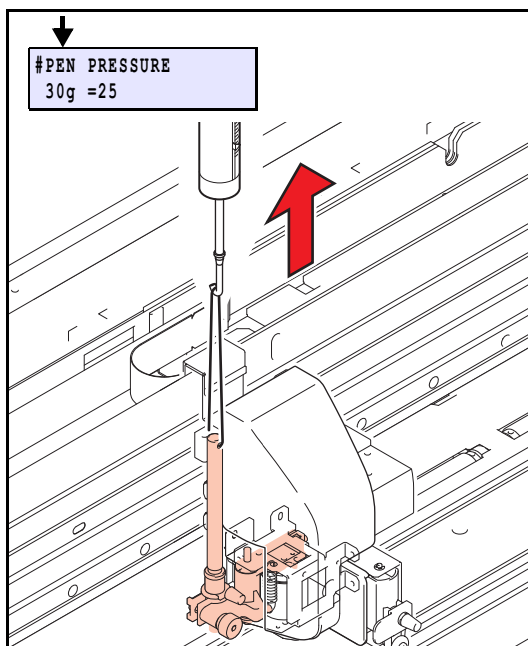
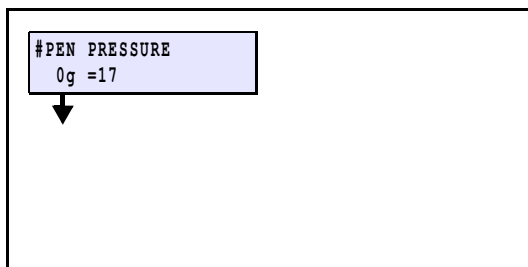
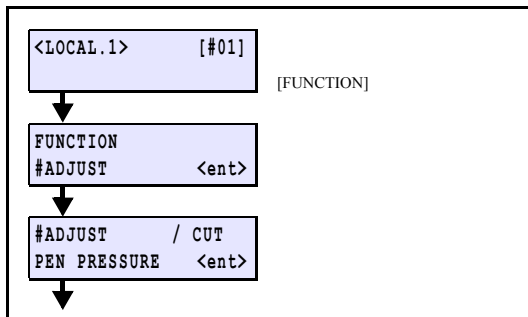
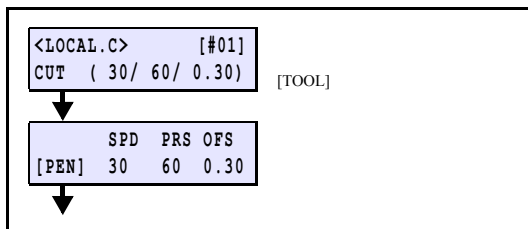

1. Set media, and set the adjustment pen on the cut head carriage.
2. Press [TOOL] with CUT MODE <Local> to set to "PEN".

3. Select [PEN PRESSURE] from the operation menu.

4. Input the value when the pen tip comes in close contact with the media and finalize the entry. (0g adjustment)

[▲]/[▼]: Modifies the compensation value.

[ENTER]: Finalizes (To the next compensation screen)



Select a little higher value so that the pen tip will be in close contact with the sheet.

5. Pull up the adjustment pen with a tension gauge at 30 g, repeat up and down several times and input the value when the pen tip starts leaving the sheet. (30g adjustment)

[▲]/[▼]: Modifies the compensation value.

[ENTER]: Finalizes (To the next compensation screen)

1

2

3

4

5

6

7

8

4.2.9 PEN PRESSURE

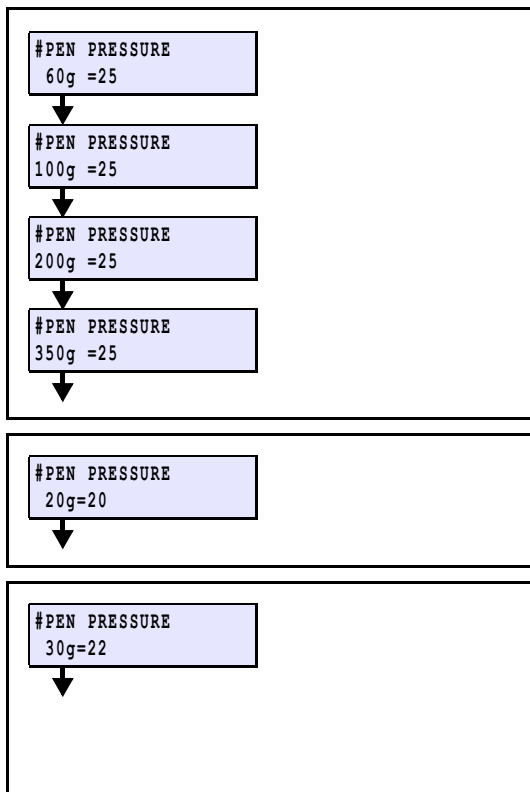

6. Carry out each adjustment by up to 350 g following the methods described above. (60, 100, 200, 350g)

7. Check the pen pressure using the tension gauge as necessary.

[FUNCTION]: Indicates the pen pressure

8. Check the pen pressure (10-350g) at appropriate pressure levels before completing all the adjustments. (in 2 g steps)

[▲]/[▼]: Selects a pen pressure level

[END]: Completes

1

2

3

4

5

6

7

8

4.2.10 LANDING

1.2

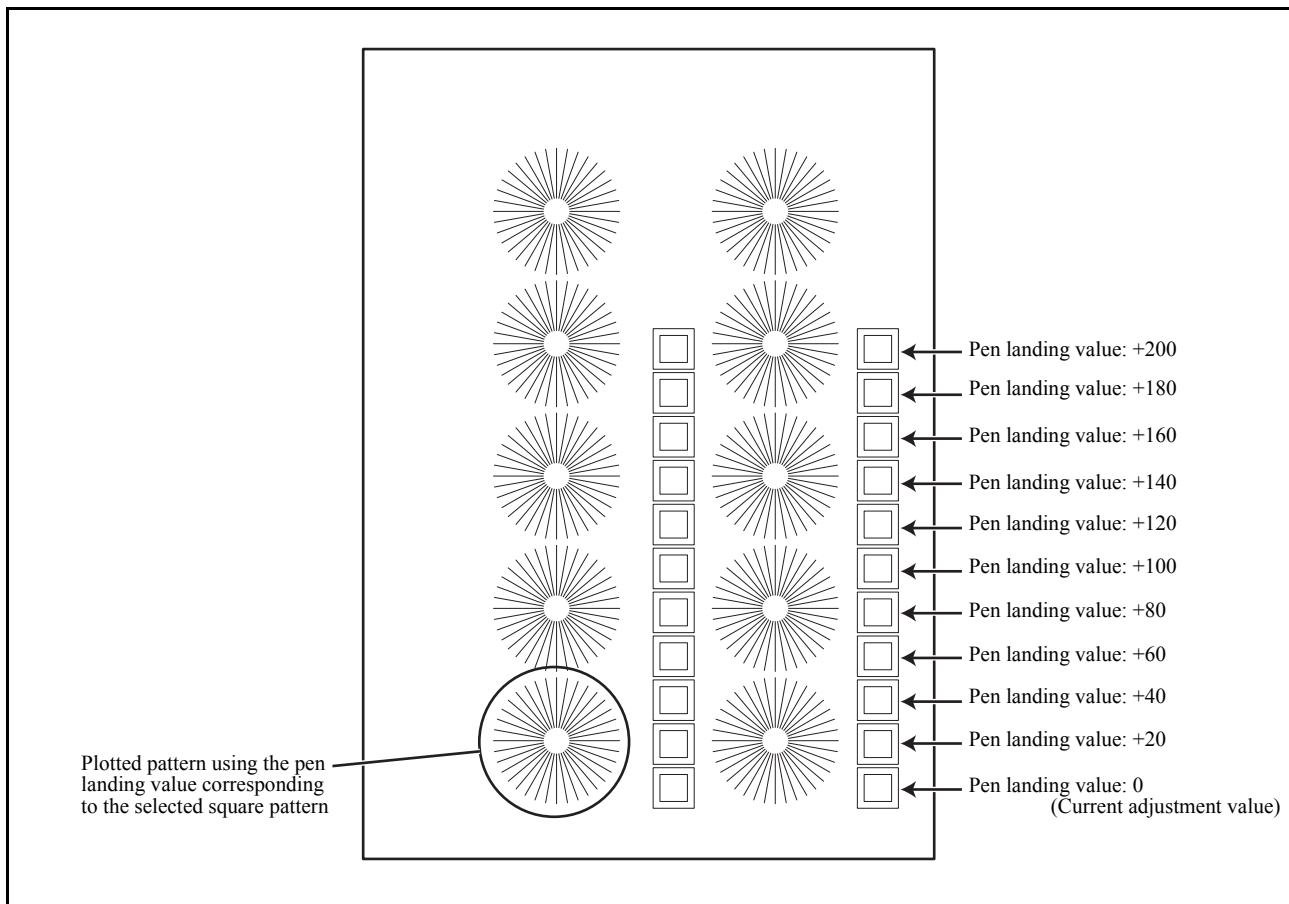

1

2

3

4

5

6

7

8

■ Function

- Make this adjustment after completing the pen pressure adjustment.
(Use the following four different adjustment patterns.)

[REMOTE]: Plots 11 square patterns at the positions of different pen landing values in steps of 20, starting at the first pen landing point.
Plots the square patterns in two rows (near the right end and the center of the media) using the same set of landing values.

[FUNCTION]: Plots a radial pattern using the pen landing value selected based on the square patterns, four radial patterns using the pen landing values one to four larger than the selected value, and five radial patterns using the values one to five smaller. (4 steps)

[◀]: Plots four square patterns and 32 4-mm straight lines.

[▶]: Plots a broken line between pinch rollers.

- The adjusted values are registered as system parameters (No.7 and 9).
- The content of adjustment is as follows:
 - #LANDING UP POSITION
 - Pen landing
 - Cutter landing

4.2.10 LANDING

■ Procedure

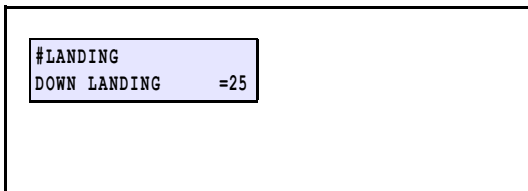
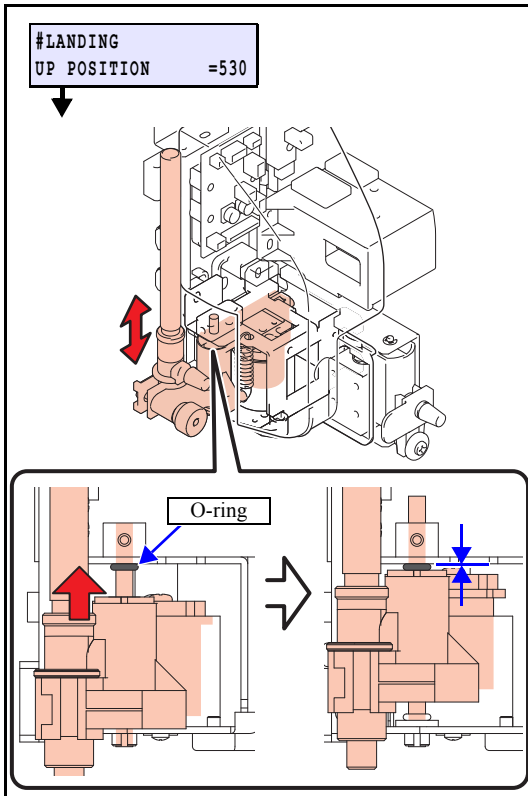
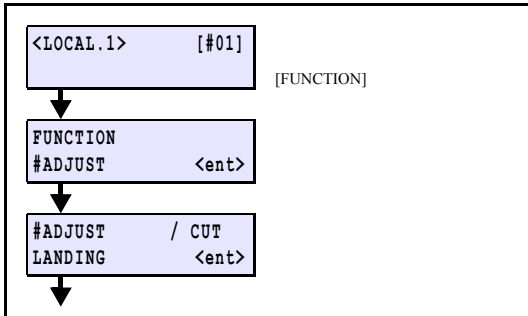
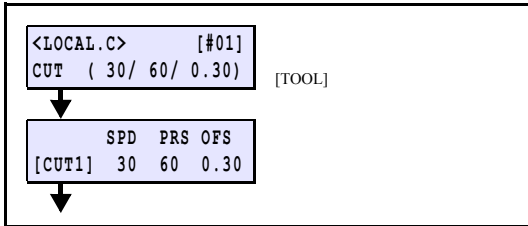

1. Set media, and attach the supplied pen to the cut head carriage.

2. Select [LANDING] from the operation menu.

3. Move the pen shaft up or down with the JOG key until the O-ring comes in contact with the bushing holder.

[▲]/[▼]: Up or down motion (in steps of 1 press)



If the O-ring is already in contact with the bushing holder before adjustment, move the pen shaft down once with the JOG key and then start adjusting the position.

4. Press [FUNCTION], and the pen will descend and ascend. At the up position, check to see that the top surface is in contact with O-ring.



The pen repeats down and up motion every 20 seconds.

5. Press [ENTER] to store the setting value and move to [DOWN LANDING].

6. Select one of the following drawing patterns and draw the pattern. (Generally, the square at the next step)

[◀]: Draws a square and straight line.

[▶]: Draws a broken line.

[FUNCTION]: Draws radial lines consecutively.

[REMOTE]: Draws squares consecutively.

[FEED]: Moves to Cut landing adjustment.

1

2

3

4

5

6

7

8

4.2.10 LANDING

1.2

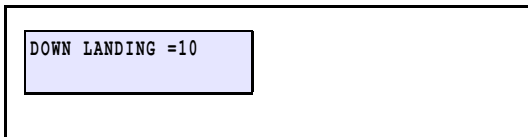
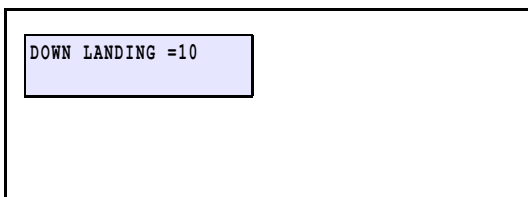
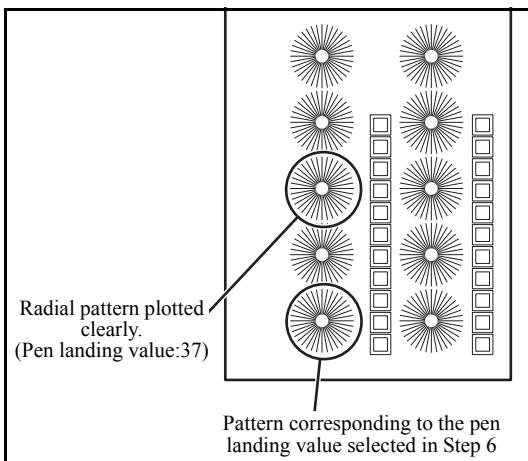
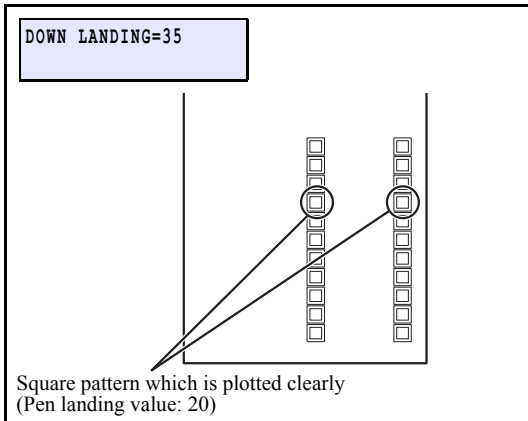
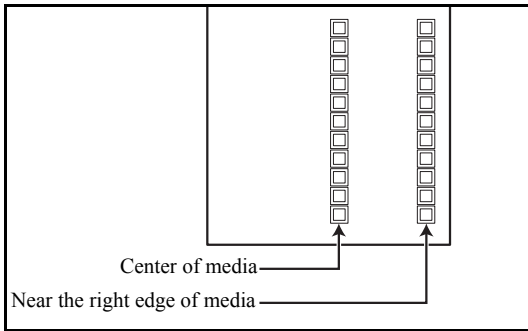

7. Plots 11 square patterns using different pen landing values in steps of 20, starting with the currently set pen landing value.

[REMOTE] : Plots square patterns.

[END] : Stops plotting.

8. Input the value corresponding to the square pattern which meets the following criterion:

Criterion: The first square pattern whose lines are uniform in thickness found by checking that is to be started from pen landing value "0".

[▲]/[▼]: Modifies the compensation value.

9. Plot radial patterns to find out the best pen landing value.

Plot 10 radial patterns using the pen landing values from -20 to +16 based on the pen landing value registered in Step 5. (4 steps)

[SHEET SET]: Plots radial patterns.

[END]: Stops plotting.

10. Input the value corresponding to the radial pattern which meets the following criterion.

Criterion: The middle one of the radial patterns whose lines are uniform in thickness.

[▲]/[▼]: Modifies the compensation value.

11. Register the input value.

[ENTER]: Registers



- If a satisfactory pattern cannot be obtained only by pen landing adjustment, change the end pressure value and pen up value. (After changing the values, be sure to perform pen landing adjustment again.)

- Adjust the up landing and the end press by clicking [USER TYPE / TOOL].

1

2

3

4

5

6

7

8

4.2.10 LANDING

1.1

■ Cutter landing adjustment procedure

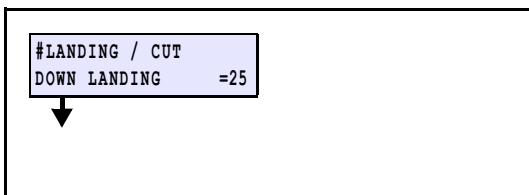

1. Select [SPEN LANDING].

The LCD indicates the present pen landing value and the pen moves up and down repeatedly.

[CLEANING/FEED]: Selects

2. Select [CUT LANDING].

The LCD indicates the present cut landing value and the pen moves up and down repeatedly.

[CLEANING/FEED]: Selects

3. Register the input value.

[ENTER]: Registers



Basically, the value of pen landing and cut landing can be the same.

An adjusted value of pen landing is automatically reflected in a cut landing value in the CJV series. If a value of cut landing is modified independently, such a modification is not reflected in the value of pen landing.

1

2

3

4

5

6

7

8

4.2.11 [PHOTO SENSOR] SENSOR LV.

1.2

■ Function

Carries out automatic compensation of output value so that the mark sensor on the cut head carriage can perform read operation correctly.

This operation is carried out in the case where the read operation by the mark sensor is unworkable. (“User menu” also has the same function.)



- The registration mark detection can not be achieved correctly under such conditions that there is any print or stain in the area scanned by the sensor. To avoid such problem, use unprinted or unstained white paper under the sensor.
- Set the media used, or lay and set three sheets of copy paper on top of another. Set unstained white paper (as specified above).

■ Procedure

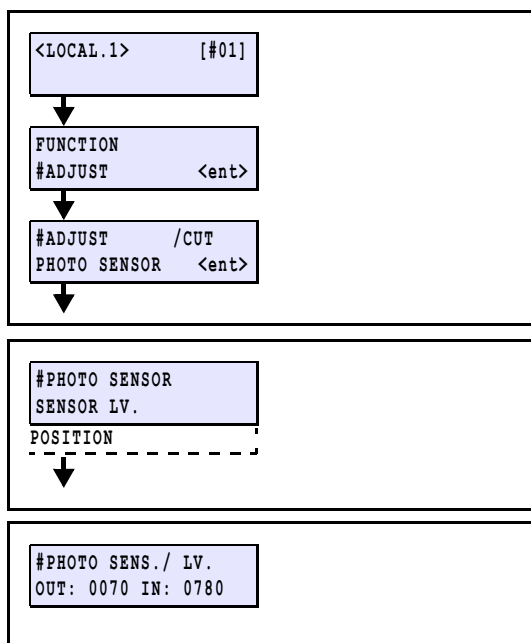

1. Set media mentioned above directly below the mark sensor, and set the media clamp to “HIGH”.

2. Select [#PHOTO SENSOR] from the operation menu.

3. Select the [SENSOR LV.] and press [ENTER].

[▲]/[▼]: Changes items

[ENTER]: Finalizes (To the next compensation screen)

4. Register an optimum value (automatically displayed).

CJV30 will automatically select an optimum value.

Therefore, wait until the display shows a fixed value and then enter the value.

[ENTER]: Registers



- The display may not become so steady that it keeps showing only one fixed number. In that case, press the [ENTER] key when the value of the high-order digit on the display is fixed.
- Pressing [FUNCTION] will release the heads from the drive.

1

2

3

4

5

6

7

8

4.2.12 [PHOTO SENSOR] POSITION

1.1

■ Function

Correct the mechanical misalignment between the pen tip and the mark sensor by automatic compensation.
Checks the position when the parameter has been initialized or the misalignment occurs during cutting operation with the mark sensor being activated.



- Perform this adjustment after the completion of adjusting the location of mark sensor and adjusting the sensitivity of mark sensor.
- Do not use commercially available pens other than the specified ones.
Since the pen tip is not aligned with the center of the pen holder, adjustment is not made correctly.
- Do not use the attached pen adapter (M601251).
- To perform this adjustment, use the dedicated pen holder (M006474).

■ Procedure

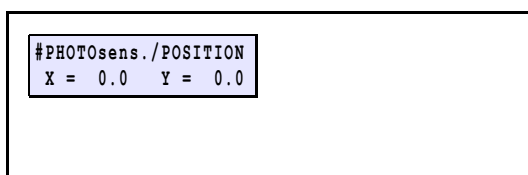
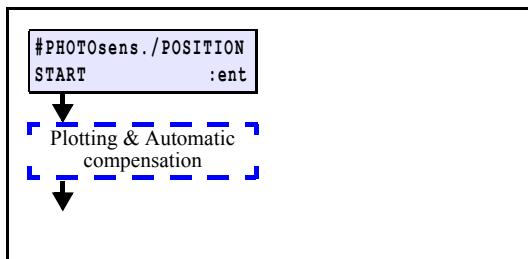
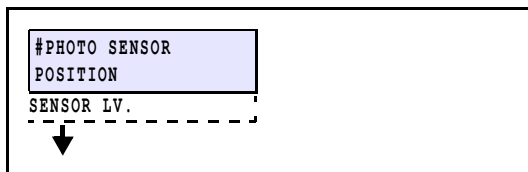
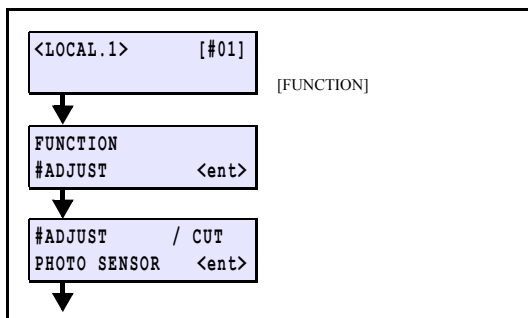
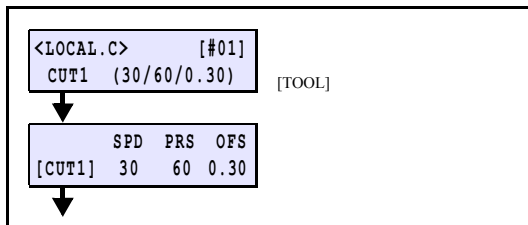

1. Set media, and attach the pen to the cut head carriage.



When no media is set: the plotter waits for input of a compensation value without plotting.

2. Press [TOOL] with CUT MODE <Local> to set to “PEN”.

3. Select [PHOTO SENSOR] from the operation menu.

4. Select the “POSITION” and press [ENTER].

[▲]/[▼]: Changes items

[ENTER]: Finalizes (To the next compensation screen)

5. Carry out plotting of the pattern by pressing [ENTER]. If the pen tip is not in alignment with the sensor, the plotter plots the adjustment pattern again.



Readjust “SENSOR LV” (4.2.11) if read operation by mark sensor fails.

6. Check the compensation value.

[ENTER]: Checks.

1

2

3

4

5

6

7

8

4.2.13 GR/PR POSITION

1.1

■ Outline

Makes the printer recognize the positional relation between the grid roller and the pinch roller.

Readjusts the position of grind roller and the pinch roller when the parameter has been initialized or when an error occurs even if the position of the pinch roller is within an acceptable range upon media detection, and compensates mechanical errors.

■ Procedure

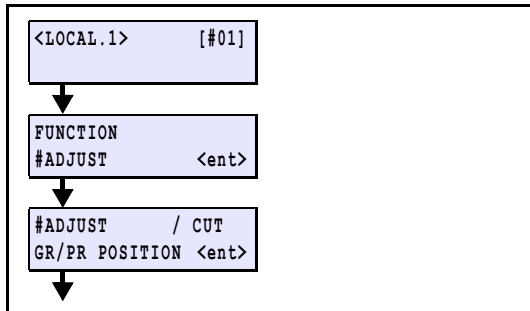

1. Select [GR/PR POSITION] from the operation menu.

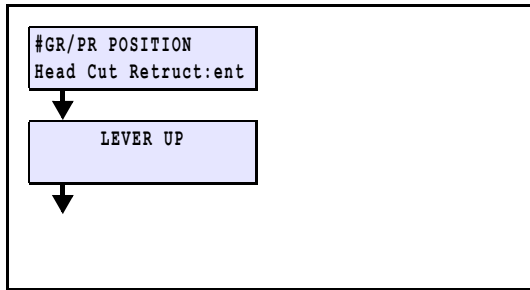

2. Check the location of the cutter, and if it is not in the parking position, move it to that position.
(If it has been parked in that position already, proceed to the next screen.)

[ENTER]: Cutter moves to the parking position.

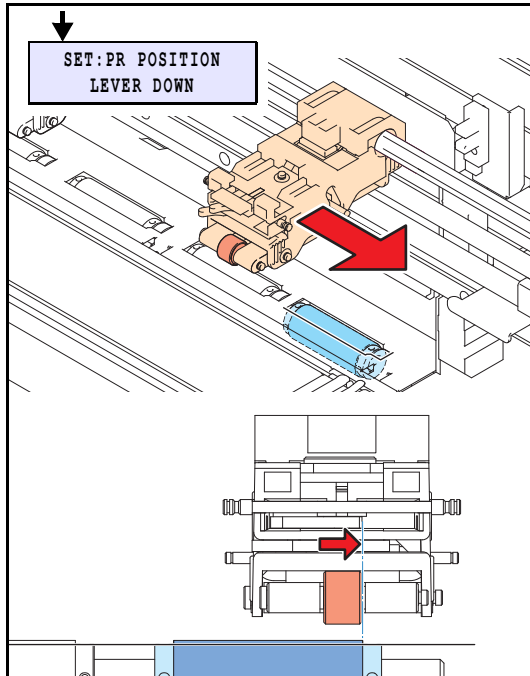

3. Hold up the clamp lever.
(If it has been held up already, proceed to the next screen.)

4. Align the both right ends of the rightmost pinch roller and the rightmost grid roller, and hold the lever down.

(Margin of error: within ± 0.5 mm)

[◀]/[▶]:

[ENTER]: Finalizes (To the next compensation screen)

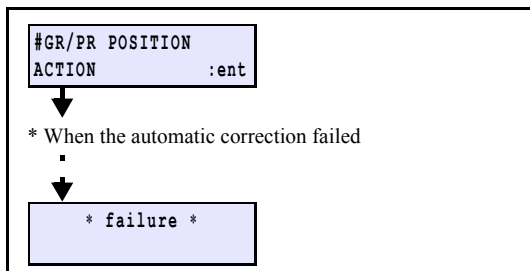

5. Carry out automatic compensation by clicking [ENTER].
After the automatic compensation is completed, return to "main menu" by clicking [END].



In case automatic compensation fails, a screen for Step 3 is displayed.

4.2.14 MOTOR CURRENT

■ Function

If hunting occurs or a hunting noise is heard when the X-axis motor and/or Y-axis motor are driven after replacing the main PCB assy, adjust the supply current to minimize the hunting.

Carries out the supply current adjustment while the cutter head is connected. The adjusted value is stored in the control system parameters.

Adjustment items are as follows.

STOP ADJUST	: Adjustment during the resting state
X MOVING ADJUT	: Adjustment during the X motor is being activated.
Y MOVING ADJUT	: Adjustment during the Y motor is being activated.

■ Procedures for STOP ADJUST

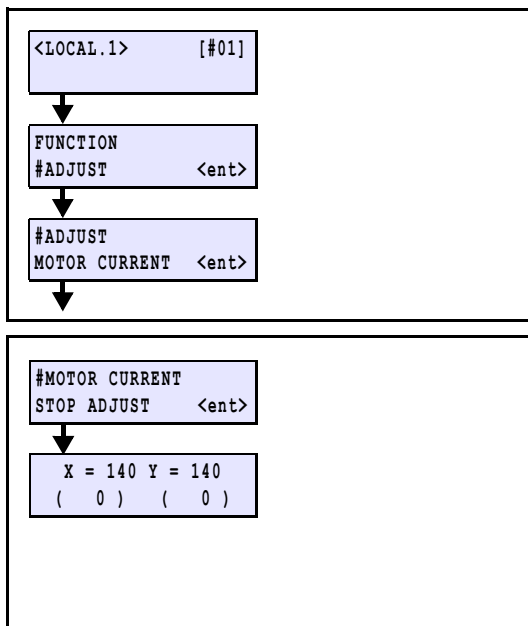

1. Select [MOTOR CURRENT] from the operation menu.

2. Carry out the [STOP ADJUST] and adjust the current value so that the hunting noises at the X and Y-axis motors are as minimized as possible.

[◀]/[▶]: Motor changeover
 [▲]/[▼]: Modification of D/A value
 [ENTER]: Executes
 [END]: Returns

■ Procedures for X MOVING ADJUT

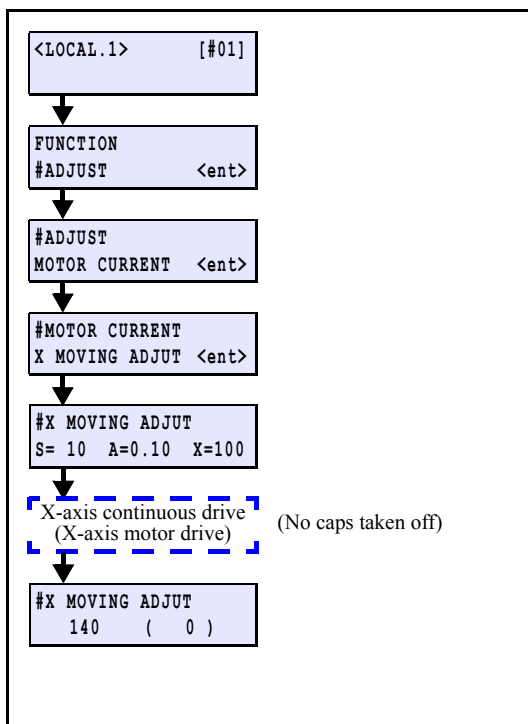

1. Select [MOTOR CURRENT] -> [X MOVING ADJUT] from the operation menu.

[▲]/[▼]: Changes items
 [ENTER]: Finalizes (To the next compensation screen)

2. Input the following test conditions and execute the function.

Speed (S): 5 to 10 mm/s
 Acceleration (A): 0.2 G
 Length (X): About 50 to 100 mm

3. Adjust the value so that the hunting sound during the X motor running is minimized.
 Check the hunting sound of the X motor at rear left.

4. Press [END] several times to complete the X-axis motor current adjustment.

[▲]/[▼]: Changes the value
 [◀]/[▶]: Moves
 [ENTER]: Executes
 [END]: Returns

4.2.14 MOTOR CURRENT

■ Procedures for Y MOVING ADJUT

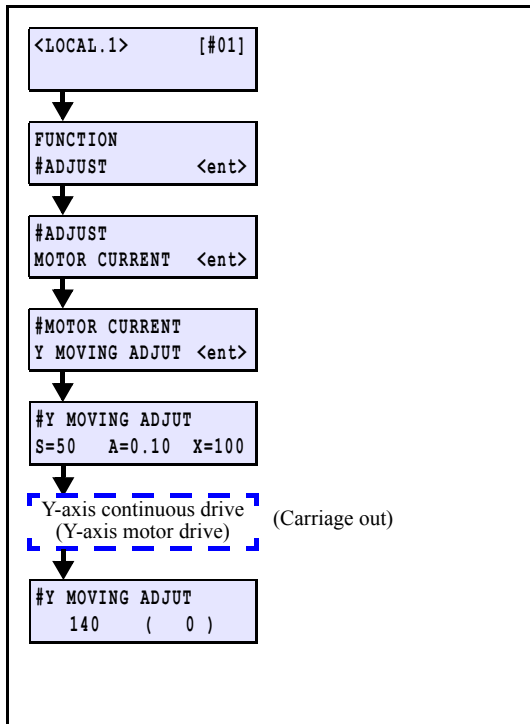

1. Select [MOTOR CURRENT] -> [Y MOVING ADJUT] from the operation menu.

[▲]/[▼]: Changes items

[ENTER]: Finalizes (To the next compensation screen)

2. Input the following test conditions and execute the function.

Speed (S): 5 to 10 mm/s

Acceleration (A): 1.0 G

Length (X): About 50 to 100 mm

3. Adjust the value so that the hunting sound during the Y motor running is minimized.

Check the hunting sound of the Y motor at right side.

4. Press [END] several times to complete the Y-axis motor current adjustment.

[▲]/[▼]: Changes the value

[◀]/[▶]: Moves

[ENTER]: Executes

[END]: Returns



To check the hunting sound, return to LOCAL mode by pressing [END] and operate a JOG key.



Hunting noise remains on rare occasions after adjustment.

Follow procedures below to rough identification of X-axis with hunting noise and review the adjusted value.

- 1 In LOCAL, press [▲][▼][◀][▶] KEY to change to the origin setting mode.

- 2 Confirm X-axis hunting noise in origin setting mode.

Press [▲][▼] KEY for several times in turn.

If hunting noise continues after motor is stop, adjustment value is not set properly.

Perform [X MOVING ADJUST] to re-adjust the current value.

- 3 Confirm Y-axis hunting noise in origin setting mode.

Press [◀][▶]KEY for several times in turn.

If hunting noise continues after motor is stop, adjustment value is not set properly.

Perform [Y MOVING ADJUST] to re-adjust the current value.

- Standard current set value is 125-150.

1

2

3

4

5

6

7

8

4.2.15 PRINT/CUT POS.

1.1

■ Outline

Correct the mechanical position aberration of the print head and the nozzle, and raise the precision of printing and cutting while the mark sensor is not used.

The machine draws registration marks with the print head and cut head, reads the positions of the marks with the mark sensor and corrects the position error automatically.

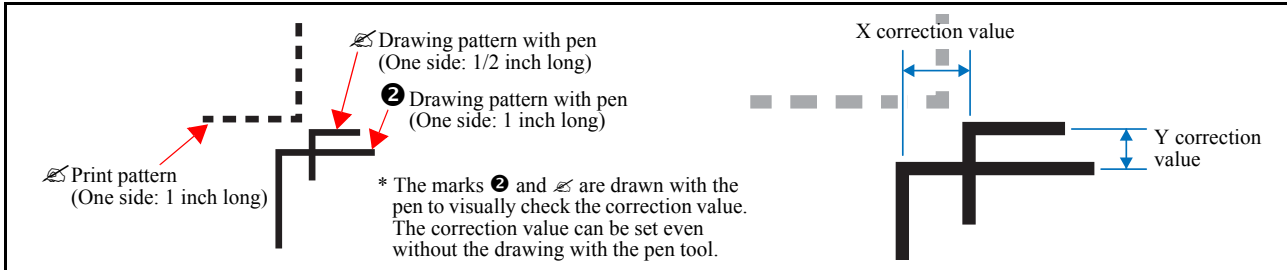

■ Procedure

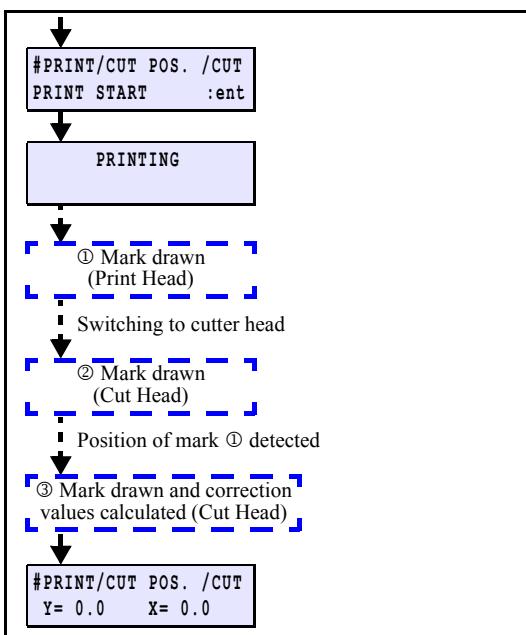
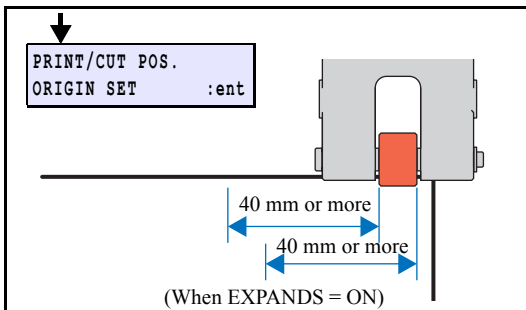
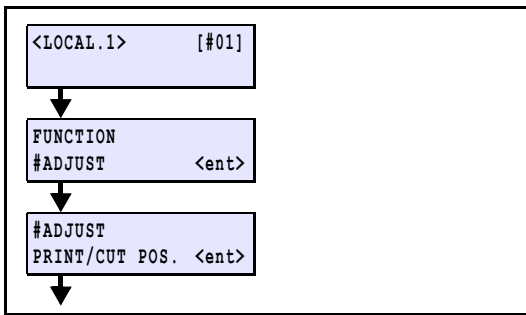

1. Select [PRINT/CUT POS.] from the operation menu.



Before starting the adjustment, check to see that the connection unit is connected to the printing head.

2. Set the origin at the distance of 40 mm or more from the inner edge of the rightmost pinch roller and press [ENTER].



When EXPANDS is set to ON, set the origin 40 mm or more away from the outer edge of the pinch roller.



The adjustment is not made precisely unless the origin is set properly.

3. Press [ENTER] to start the adjustment.



If a mark detection error occurs, execute “4.2.11 [PHOTO SENSOR] SENSOR LV.” and perform this adjustment again.

The correction values are determined from the positional difference between the mark ①, which is drawn at the corner of ③, and the mark ②.

4. Check the correction values on the LCD and then press [ENTER] to register correction values and complete the adjustment.



Pressing [END] will terminate the adjustment without registering the correction values.

4.2.16 SERIAL No.

■ Function

Confirms and sets the serial number. 8 characters of alphabet and numeral (0-9, A-Z) can be input.

Because the serial number is input before shipment, field entry is impossible. Reenter the parameter only if it has been initialized.

■ Procedure

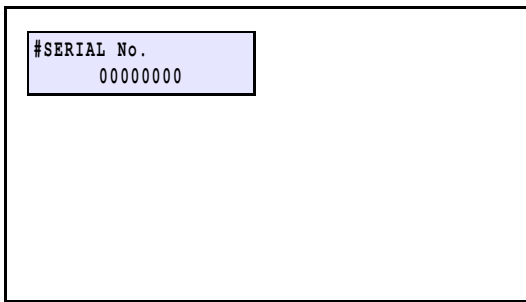
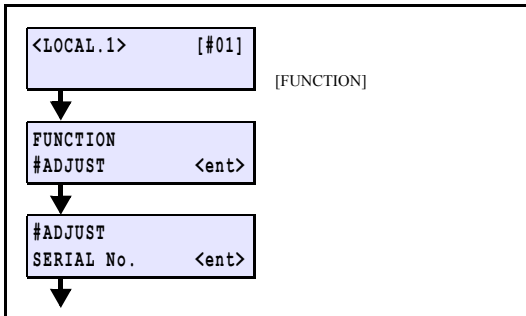

1. Select [SERIAL No.] from the operation menu.

2. Enter (Confirm) the serial number.

[▲]/[▼]: Change the numerals.

[◀]/[▶]: Moves the cursor.
(When the cursor is in the left or the right end, key input does not work.)

[ENTER]: Finalizes

[END]: Cancellation of input



If the serial number has been set, it cannot be changed.

1

2

3

4

5

6

7

8

4.2.17 DEALER No.

■ Function

Confirms and sets the dealer number. 8 characters of alphabet and numeral (0-9, A-Z) can be input.

■ Procedure

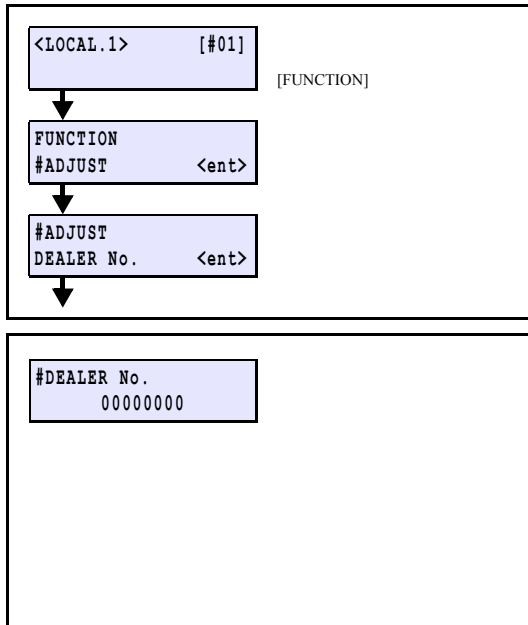

1. Select [DEALER No.] from the operation menu.

2. Enter (Confirm) the dealer number.

[▲]/[▼]: Change the numerals.

[◀]/[▶]: Moves the cursor.
(When the cursor is in the left or the right end,
key input does not work.)

[ENTER]: Finalizes

[END]: Cancellation of input

1

2

3

4

5

6

7

8

4.2.18 DEFAULT SET

■ Function

Sets the selected parameters to the initial values.

No.	Item	Operation	Remarks
1	SETUP PARAMETER	1. Initialize the user operation setting value. 2. Sets user No. to 1. 3. Initialize the language to be used. 4. Initialize the user dot position compensation value. 5. Sets to maintenance close.	Always selectable
2	MAINTENANCEparameter	Initialize the parameter in question.	
3	CUSTOMIZE PARAMETER	Initialize the parameter in question.	
4	RUNNING PARAMETER	Initialize the parameter in question.	
5	EXCHANGE PARAMETER	Initialize the parameter in question.	
6	INK-SYSTEM PARAMETER	Initialize the parameter in question.	

■ Procedure

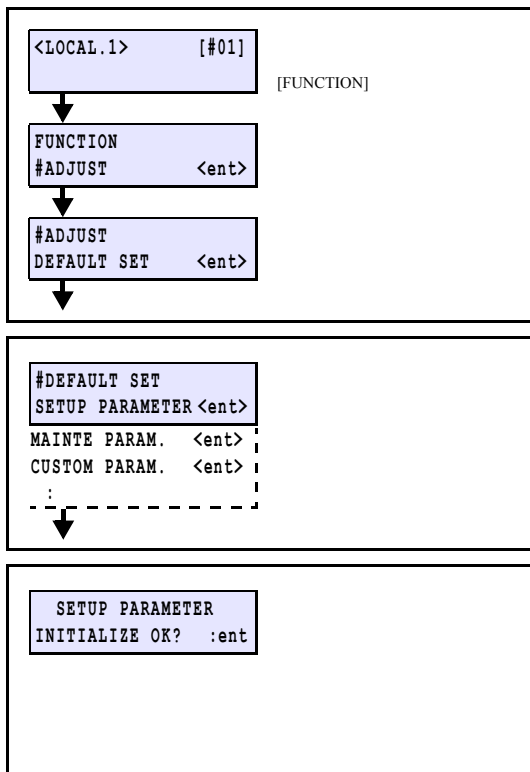

1. Select [DEFAULT SET] from the operation menu.

2. Select items to be initialized.

[▲]/[▼]: Switches the parameter item display.

[ENTER]: Finalizes

3. Initialize the selected parameter.

[ENTER]: Executes the initialization.

1

2

3

4

5

6

7

8

4.2.19 REPLACE PARTS

■ Function

Displays the replacement history of the following parts/unit or registers replacement date thereof.



In this machine, the timing for replacement of parts is determined based on this item. When a part in question is replaced, never forget to register the replacement date.

■ Parts subject to the replacement

Type	Part number
PUMP	Enter the date only. (Do not input the number.)
CAP	Enter the date only. (Do not input the number.)
DUMPER	Registration of A to H (nozzle number)
Print Head	*As for a head, since the replacement date is automatically recorded at start-up after replacement, the registration is not required. (Confirmation of history is possible.)

■ Registration procedure

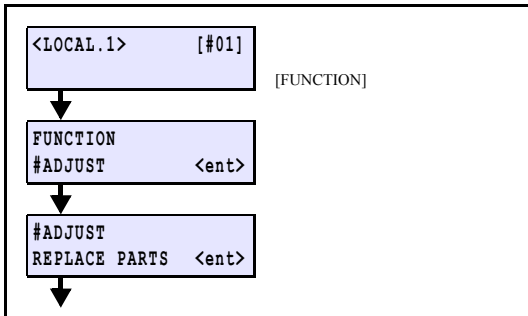

1. Select [REPLACE PARTS] from the operation menu.

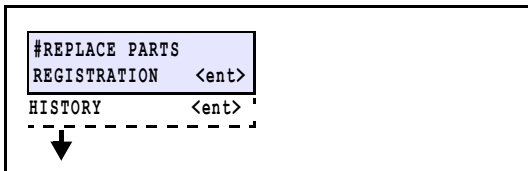

2. Select [REGISTRATION].

[▲]/[▼]: Changes items

[ENTER]: Finalizes (To the next screen.)

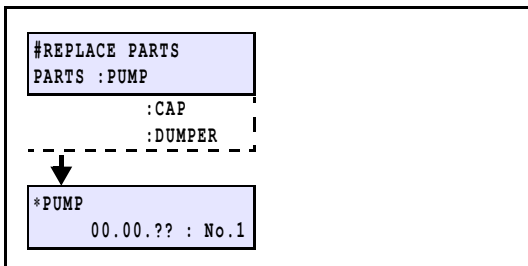

3. Select the parts replaced and register the date and the part number referring to the list shown above.

[▲]/[▼]: Switches the names of parts.

[ENTER]: Finalizes (To the next screen.)

■ Example of displaying the part-replacement history

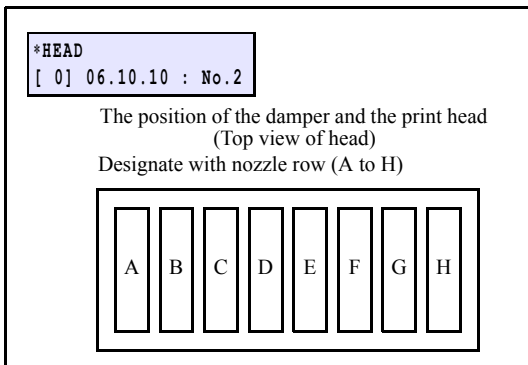

To see the part-replacement history, select [HISTORY] in Step 2 and make the appropriate part displayed.

[▲]/[▼]: Switches the display of the parts.

1

2

3

4

5

6

7

8

1

2

3

Adjustment Items

4.1

Operation Matrix

4.2

Adjustment Function

4.3

Mechanical Adjustment

4

5

6

7

8

4.3.1 Adjusting the Location of Mark Sensor

1.1

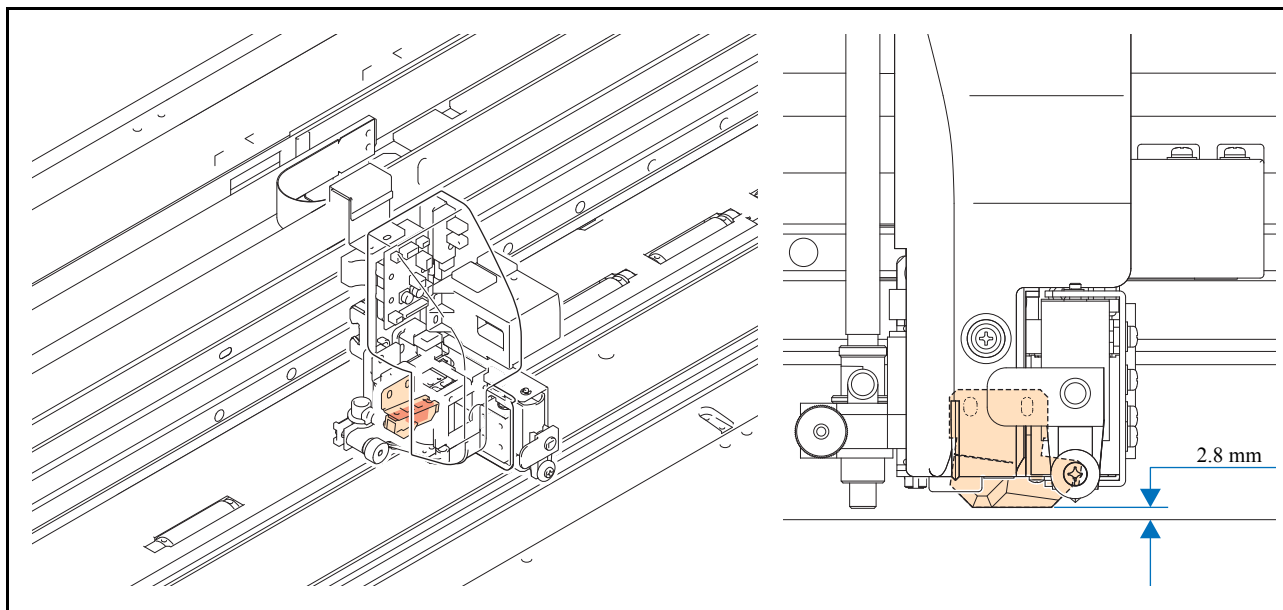

Function

Adjust the distance between the mark sensor (photo sensor) and the platen to the specified value.



- Set the pressure of all the clamps to Middle, and make the adjustment on the right station side.
- This adjustment is to be made mechanically without using any [#ADJUST] item. After completion of this adjustment, however, make the adjustments of [PHOTO SENSOR] among the [#ADJUST] items.

Procedure

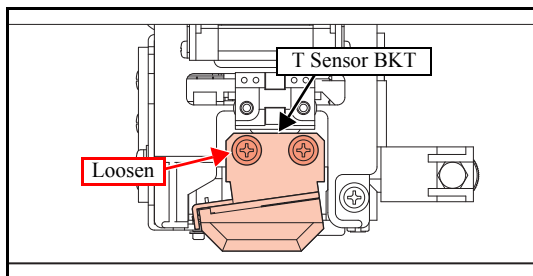

1. From the back side of the printer, loosen the screws that hold the T sensor BKT.



When no sheet is set: the plotter waits for input of a compensation value without plotting.

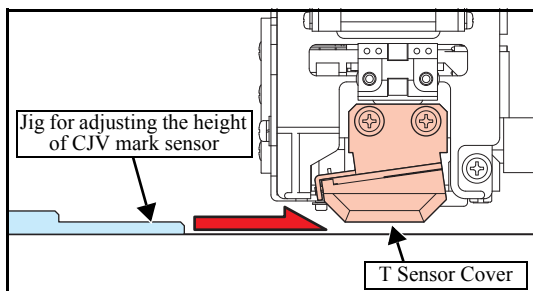

2. Insert the clearance gauge between the pen line film and the bottom surface of the T sensor cover.

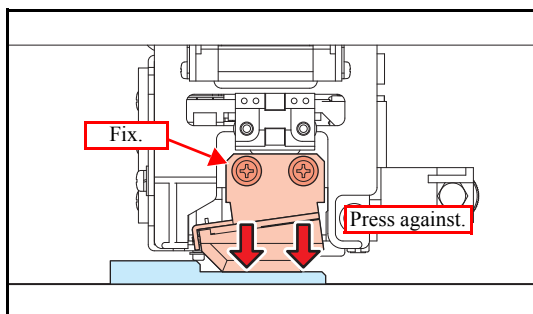

3. Check whether the right and left T sensor covers are fixed under the conditions that each of them is in close contact with the clearance gauge, then tighten up the screws.

1

2

3

4

5

6

7

8

4.3.2 Adjustment of the Mounting Location for the Cutter

1.1

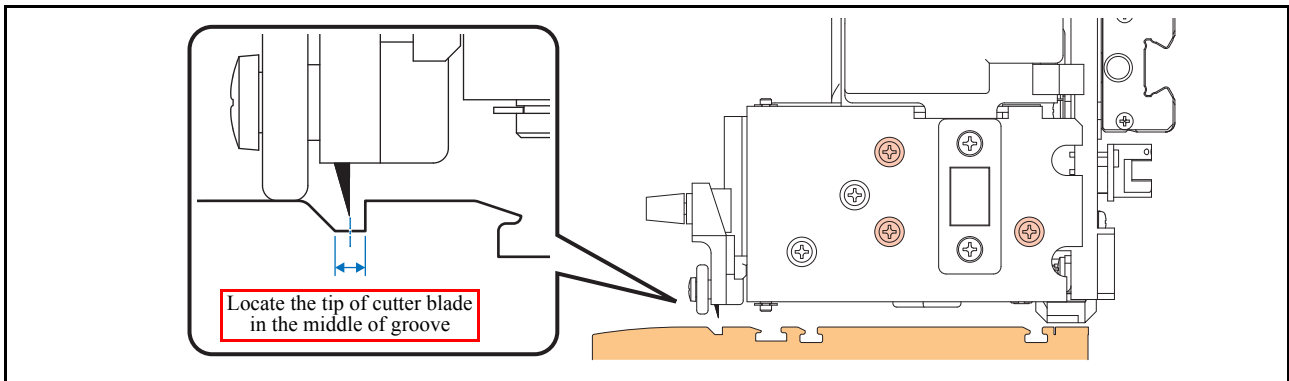

Function

Adjust the cutter location in the back-and-forth direction by moving the cutter unit back and forth while visually checking the location.

Procedure

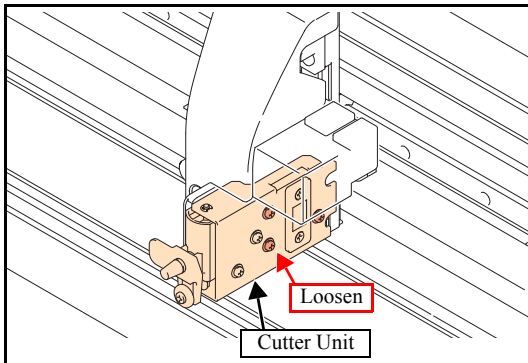

1. Loosen the screws shown in the diagram to the degree whereby the cutter unit can be held loosely.
2. Push down the clamp lever.



Be sure to make the adjustment while the clamp lever is lowered.

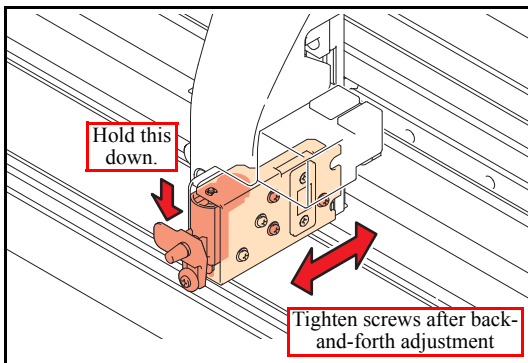

3. Push down the cutter blade and adjust the back-and-forth location of the unit so that the tip of the cutter blade is located in the middle of the groove. Then tighten the loosened screws.

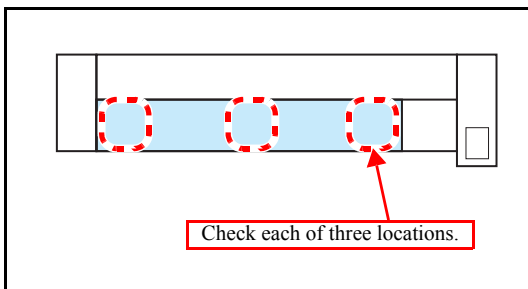

4. Move the head unit manually and push down the cutter blade assy at each right, center and left end on the platen, to check back-front positioning.



On rare occasions, the blade comes out of the slot because of assembly errors or fluctuation in part accuracies. In such a case, adjust again to the back-front optimum position where the blade is always in whole slot on the platen.

1

2

3

4

5

6

7

8

4.3.3 Adjustment of the Station Height

■ Outline

■ Procedure

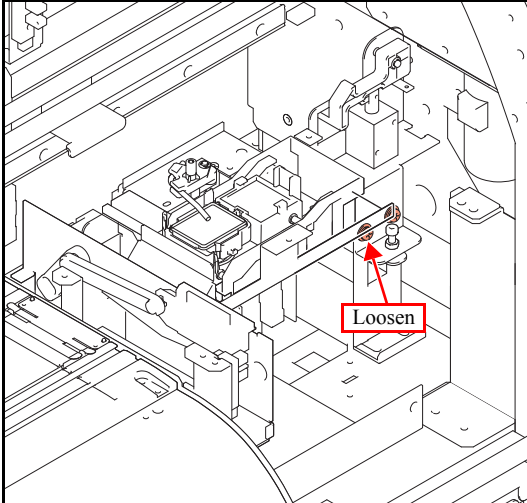

1. Loosen the two screws used for station-base adjustment.

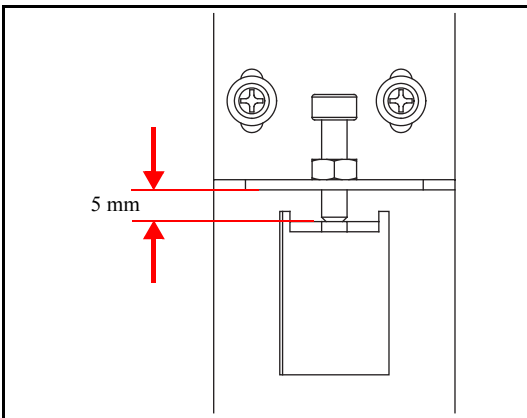

2. Loosen the hexagon socket head screws and make an adjustment to set their thickness gauge at 5 mm, then tighten the nuts.

3. Tighten up two loosened screws used for station-base adjustment and fix them at 5 mm in thickness gauge.

1

2

3

4

5

6

7

8

4.3.4 Adjustment of the Wiper Height

■ Outline

■ Procedure

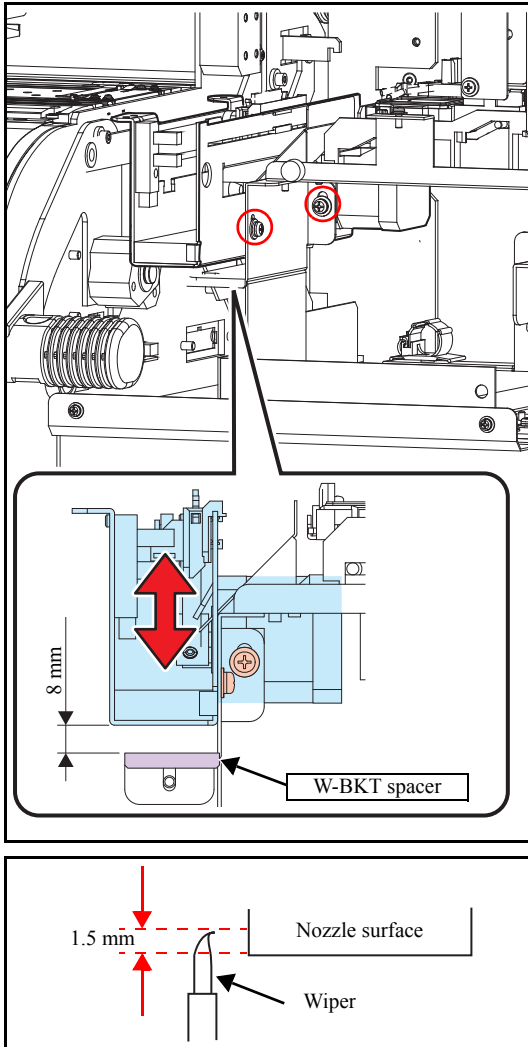

1. Loosen the wiper height adjusting screws (x2), and temporarily adjust the screws until the thickness gauge is 8mm.
2. Loosen the screws (x2) on the head cover front, and then tighten the screws while holding the height adjustment lever in the lowest position to fix the head in place.

3. Move the head, and adjust the wiper so that there is approximately 1.5 mm from the nozzle surface.

1

2

3

4

5

6

7

8

4.3.5 Positioning of the Encoder Sensor

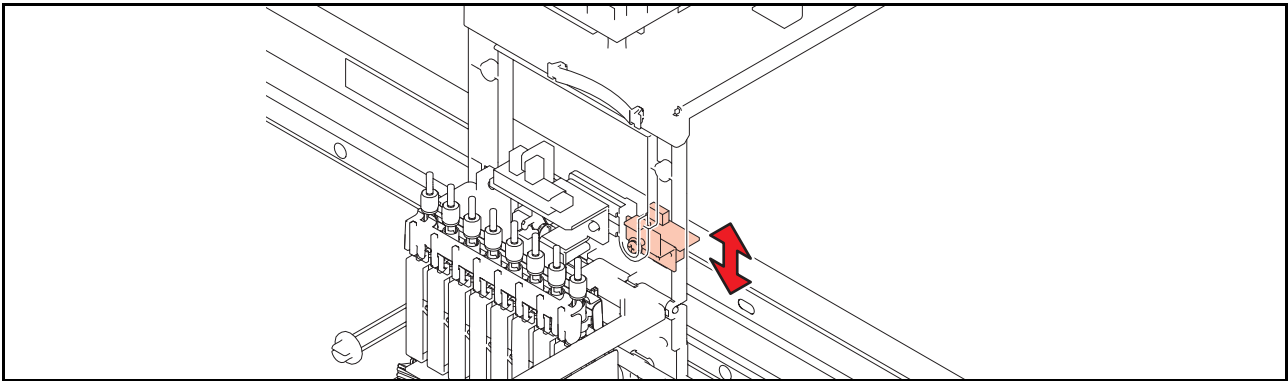

■ Function

■ Procedure

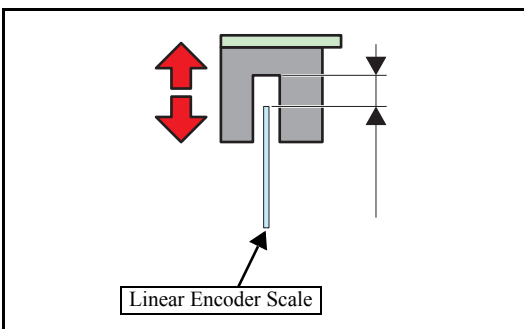

1. Loosen the screws on the L sensor BKT.

Refer to [6.5.12 Encoder PCB Assy](#) for details concerning its assembly and disassembly.

2. Adjust the height of the encoder PCB Assy and fix it with screws.

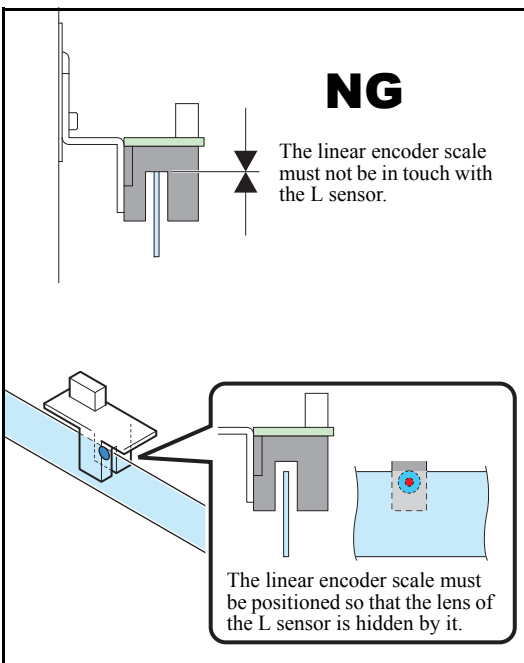

3. Check the following two items when moving the print head carriage manually from the right end to the left end on the main body.

- The upper part of the linear encoder scale is not in touch with the L sensor.
- The exposed lens of the L sensor is not over the height of the linear encoder scale.



After fixing the L sensor BKT, check whether no abnormality is found by conducting the following [#TEST].

- [5.1.26 LINEAR ENCODER](#)

1

2

3

4

5

6

7

8

4.3.6 Centering of the Roll Holder

■ Outline

Carry out centering so that the axes of roller holder (axis of both feeding side and take-up side) are aligned, by positioning them face-to-face.

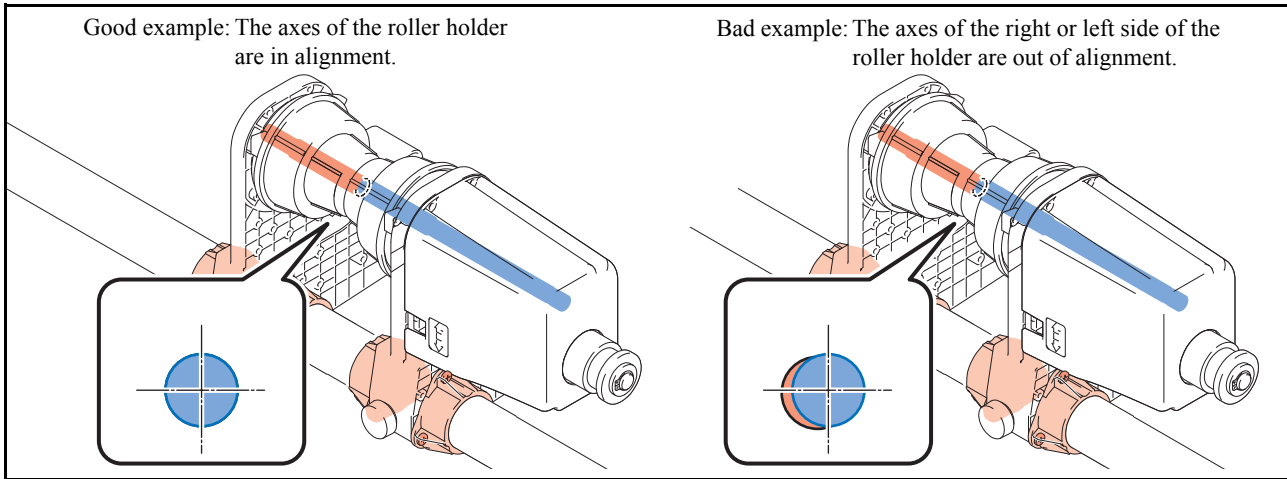

■ Adjustment procedure

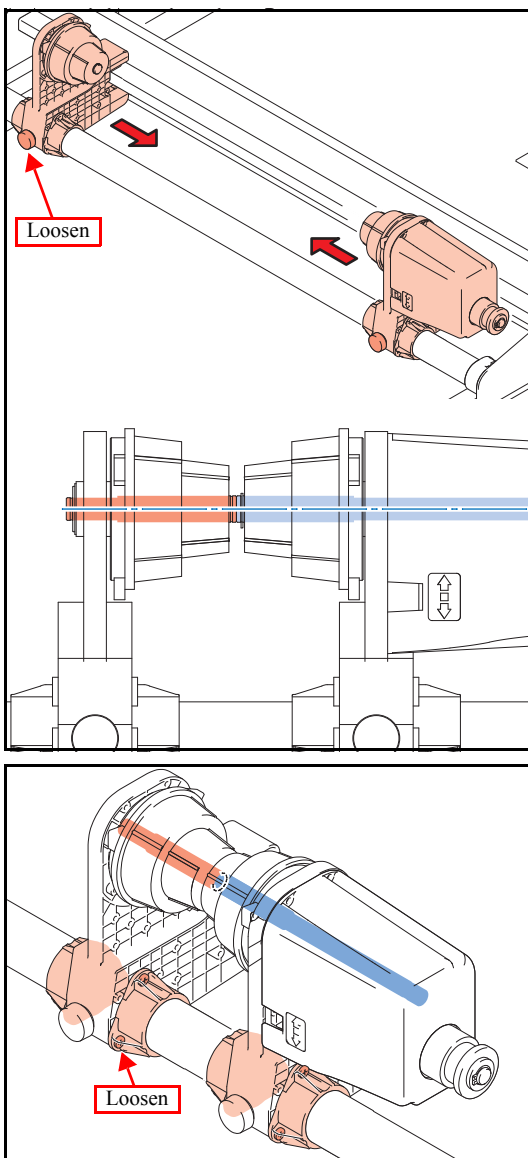

1. Carry out centering so that the axes of roller holder are aligned by positioning the feeding side and the take-up side face-to-face.

2. In case their axes are not aligned, make adjustment after loosening the screws of the bushing.

3. After the both axes have been aligned, tighten up screws and check for any misalignment of axis at the right, left and central part of the main body.

1

2

3

4

5

6

7

8

4.3.7 Positioning of the Wiper Drive Link

■ Outline

■ Procedure

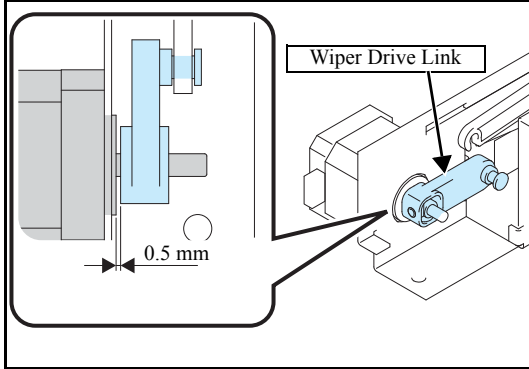

1. After setting the clearance between the motor base and the wiper drive link at 0.5 mm, check whether the wiper moves smoothly.

1

2

3

4

5

6

7

8

1

2

3

4

Test Items

**5.1
Test Function**

**5.2
Other Test**

5

6

7

8

5.1.1 [CHECK PATTERN] PATTERN

1.3

■ Operation Procedures

Step	Item	Description																														
1	Density selection	ALL, 100%, 50%, 25%, 12.5%, 6.25%																														
2	Resolution selection	360x360, 540x720, 540x900, 540x1080, 720x540, 720x720, 720x1080, 720x1440, 1440x1440																														
3	Scan direction selection	Bi-D, Uni-D																														
4	Pass No. selection	<table border="1"> <thead> <tr> <th>Resolution</th> <th>Passes (4-color)</th> <th>Passes (6-color/6-color+W/7-color/8-color)</th> </tr> </thead> <tbody> <tr> <td>360x360:</td> <td>1, 2, 4, 8</td> <td>2, 4, 8, 16</td> </tr> <tr> <td>540x720:</td> <td>2, 4, 8, 16</td> <td>4, 8, 16, 32</td> </tr> <tr> <td>540x900:</td> <td>5, 10, 20, 40</td> <td>5, 10, 20, 40</td> </tr> <tr> <td>540x1080:</td> <td>3, 6, 12, 24</td> <td>6, 12, 24, 48</td> </tr> <tr> <td>720x540:</td> <td>3, 6, 12, 24</td> <td>3, 6, 12, 24</td> </tr> <tr> <td>720x720:</td> <td>2, 4, 8, 16</td> <td>4, 8, 16, 32</td> </tr> <tr> <td>720x1080:</td> <td>3, 6, 12, 24</td> <td>6, 12, 24, 48</td> </tr> <tr> <td>720x1440:</td> <td>4, 8, 16, 32</td> <td>8, 16, 32, 64</td> </tr> <tr> <td>1440x1440:</td> <td>8, 16, 32</td> <td>16, 32, 64</td> </tr> </tbody> </table>	Resolution	Passes (4-color)	Passes (6-color/6-color+W/7-color/8-color)	360x360:	1, 2, 4, 8	2, 4, 8, 16	540x720:	2, 4, 8, 16	4, 8, 16, 32	540x900:	5, 10, 20, 40	5, 10, 20, 40	540x1080:	3, 6, 12, 24	6, 12, 24, 48	720x540:	3, 6, 12, 24	3, 6, 12, 24	720x720:	2, 4, 8, 16	4, 8, 16, 32	720x1080:	3, 6, 12, 24	6, 12, 24, 48	720x1440:	4, 8, 16, 32	8, 16, 32, 64	1440x1440:	8, 16, 32	16, 32, 64
Resolution	Passes (4-color)	Passes (6-color/6-color+W/7-color/8-color)																														
360x360:	1, 2, 4, 8	2, 4, 8, 16																														
540x720:	2, 4, 8, 16	4, 8, 16, 32																														
540x900:	5, 10, 20, 40	5, 10, 20, 40																														
540x1080:	3, 6, 12, 24	6, 12, 24, 48																														
720x540:	3, 6, 12, 24	3, 6, 12, 24																														
720x720:	2, 4, 8, 16	4, 8, 16, 32																														
720x1080:	3, 6, 12, 24	6, 12, 24, 48																														
720x1440:	4, 8, 16, 32	8, 16, 32, 64																														
1440x1440:	8, 16, 32	16, 32, 64																														
5	Drawing size selection	X size: 10mm – media length (unit: 10 mm) * Roll paper: 500000 mm Y size: 10mm – media width (unit: 10 mm)																														
6	Drawing color selection	4 colors: M, C, Y, K (M, B, Y, K with Sb51, Sb52 ink) 6 colors: M, C, Y, K, c, m (M, B, Y, K, b, m with Sb51, Sb52 ink) 6 colors+White: M, C, Y, K, c, m, W, W 7 colors: M, k, C, k, Y, m, K, c 8 colors: M, S, C, W, Y, m, K, c																														
7	Start of drawing (Waiting for key input)	[ENTER]: Starts drawing. [TEST]: Executes test drawing. [(JOG)]: Sets JOG operation mode. (Press [ENTER] to start drawing with the current position as the origin.) [REMOTE]: Switches between high speed scanning ON and OFF. [END]: Completes drawing.																														

1

2

3

4

5

6

7

8

5.1.2 [CHECK PATTERN] COLOR CHART

1.3

■ Operation Procedures

Step	Item	Description																														
1	Density selection	ALL, 100%, 50%, 25%, 12.5%, 6.25%																														
2	Resolution selection	360x360, 540x720, 540x900, 540x1080, 720x540, 720x720, 720x1080, 720x1440, 1440x1440																														
3	Scan direction selection	Bi-D, Uni-D																														
4	Pass No. selection	<table border="1"> <thead> <tr> <th>Resolution</th> <th>Passes (4-color)</th> <th>Passes (6-color/6-color+W/7-color/8-color)</th> </tr> </thead> <tbody> <tr> <td>360x360:</td> <td>1, 2, 4, 8</td> <td>2, 4, 8, 16</td> </tr> <tr> <td>540x720:</td> <td>2, 4, 8, 16</td> <td>4, 8, 16, 32</td> </tr> <tr> <td>540x900:</td> <td>5, 10, 20, 40</td> <td>5, 10, 20, 40</td> </tr> <tr> <td>540x1080:</td> <td>3, 6, 12, 24</td> <td>6, 12, 24, 48</td> </tr> <tr> <td>720x540:</td> <td>3, 6, 12, 24</td> <td>3, 6, 12, 24</td> </tr> <tr> <td>720x720:</td> <td>2, 4, 8, 16</td> <td>4, 8, 16, 32</td> </tr> <tr> <td>720x1080:</td> <td>3, 6, 12, 24</td> <td>6, 12, 24, 48</td> </tr> <tr> <td>720x1440:</td> <td>4, 8, 16, 32</td> <td>8, 16, 32, 64</td> </tr> <tr> <td>1440x1440:</td> <td>8, 16, 32</td> <td>16, 32, 64</td> </tr> </tbody> </table>	Resolution	Passes (4-color)	Passes (6-color/6-color+W/7-color/8-color)	360x360:	1, 2, 4, 8	2, 4, 8, 16	540x720:	2, 4, 8, 16	4, 8, 16, 32	540x900:	5, 10, 20, 40	5, 10, 20, 40	540x1080:	3, 6, 12, 24	6, 12, 24, 48	720x540:	3, 6, 12, 24	3, 6, 12, 24	720x720:	2, 4, 8, 16	4, 8, 16, 32	720x1080:	3, 6, 12, 24	6, 12, 24, 48	720x1440:	4, 8, 16, 32	8, 16, 32, 64	1440x1440:	8, 16, 32	16, 32, 64
Resolution	Passes (4-color)	Passes (6-color/6-color+W/7-color/8-color)																														
360x360:	1, 2, 4, 8	2, 4, 8, 16																														
540x720:	2, 4, 8, 16	4, 8, 16, 32																														
540x900:	5, 10, 20, 40	5, 10, 20, 40																														
540x1080:	3, 6, 12, 24	6, 12, 24, 48																														
720x540:	3, 6, 12, 24	3, 6, 12, 24																														
720x720:	2, 4, 8, 16	4, 8, 16, 32																														
720x1080:	3, 6, 12, 24	6, 12, 24, 48																														
720x1440:	4, 8, 16, 32	8, 16, 32, 64																														
1440x1440:	8, 16, 32	16, 32, 64																														
5	Drawing size selection	X size: 10mm – media length (unit: 10 mm) * Roll paper: 500000 mm Y size: 10mm – media width (unit: 10 mm)																														
6	Start of drawing (Waiting for key input)	[ENTER]: Starts drawing. [TEST]: Executes test drawing. [(JOG)]: Sets JOG operation mode. (Press [ENTER] to start drawing with the current position as the origin.) [REMOTE]: Switches between high speed scanning ON and OFF. [END]: Completes drawing.																														

1

2

3

4

5

6

7

8

5.1.3 [CHECK PATTERN] DROP.POS CHK

1.2

■ Drawing pattern

<Example of DROP.POS CHK pattern printing>

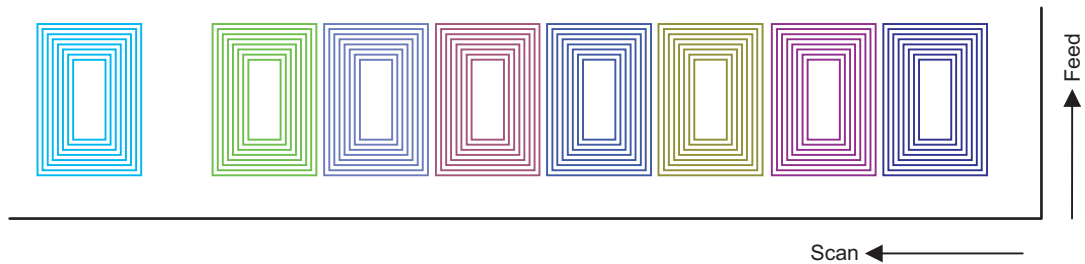
**■ Operation Procedures**

Step	Item	Description																											
1	Resolution selection	540x720, 540x900, 540x1080, 720x540, 720x720, 720x1080, 720x1440, 1440x1440																											
2	Scan direction selection	Bi-D, Uni-D																											
3	Pass No. selection	<table border="1"> <thead> <tr> <th>Resolution</th> <th>Passes (4-color)</th> <th>Passes (6-color/6-color+W/7-color/8-color)</th> </tr> </thead> <tbody> <tr> <td>540x720:</td> <td>2,4,8,16</td> <td>4,8,16,32</td> </tr> <tr> <td>540x900:</td> <td>5,10,20,40</td> <td>5,10,20,40</td> </tr> <tr> <td>540x1080:</td> <td>3,6,12,24</td> <td>6,12,24,48</td> </tr> <tr> <td>720x540:</td> <td>3,6,12,24</td> <td>3,6,12,24</td> </tr> <tr> <td>720x720:</td> <td>2,4,8,16</td> <td>4,8,16,32</td> </tr> <tr> <td>720x1080:</td> <td>3,6,12,24</td> <td>6,12,24,48</td> </tr> <tr> <td>720x1440:</td> <td>4,8,16,32</td> <td>8,16,32,64</td> </tr> <tr> <td>1440x1440:</td> <td>8,16,32</td> <td>16,32,64</td> </tr> </tbody> </table>	Resolution	Passes (4-color)	Passes (6-color/6-color+W/7-color/8-color)	540x720:	2,4,8,16	4,8,16,32	540x900:	5,10,20,40	5,10,20,40	540x1080:	3,6,12,24	6,12,24,48	720x540:	3,6,12,24	3,6,12,24	720x720:	2,4,8,16	4,8,16,32	720x1080:	3,6,12,24	6,12,24,48	720x1440:	4,8,16,32	8,16,32,64	1440x1440:	8,16,32	16,32,64
Resolution	Passes (4-color)	Passes (6-color/6-color+W/7-color/8-color)																											
540x720:	2,4,8,16	4,8,16,32																											
540x900:	5,10,20,40	5,10,20,40																											
540x1080:	3,6,12,24	6,12,24,48																											
720x540:	3,6,12,24	3,6,12,24																											
720x720:	2,4,8,16	4,8,16,32																											
720x1080:	3,6,12,24	6,12,24,48																											
720x1440:	4,8,16,32	8,16,32,64																											
1440x1440:	8,16,32	16,32,64																											
4	Drawing size selection	X size: 10mm – media length (unit: 10 mm) * Roll paper: 500000 mm Y size: 10mm – media width (unit: 10 mm)																											
5	Start of drawing (Waiting for key input)	[ENTER]: Starts drawing. [TEST]: Executes test drawing. [(JOG)]: Sets JOG operation mode. (Press [ENTER] to start drawing with the current position as the origin.) [REMOTE]: Switches between high speed scanning ON and OFF. [END]: Completes drawing.																											

1

2

3

4

5

6

7

8

5.1.4 ALL PATTERN

■ Function

The following check patterns are drawn in the block.

Check pattern	Reference page
Slant adjusting pattern	
Y-impact position adjusting pattern (DRAFT to FINE, FINE2:Four patterns in total)	

1

2

3

4

5

6

7

8

5.1.5 [MOTOR TEST] X SERVO MOTOR

1.2

■ Function

Operation test of X-axis motor is executed.

■ Operation Procedures

Step	Item	Description	Remarks
1	Speed designation	[▲], [▼]: Selects speed. Set value: 1 – 500 mm/s (unit: 1 mm/s)	[◀], [▶]: Selection of item 2 – 4
2	Acceleration designation	[▲], [▼]: Selects acceleration. Set value: 0.01 – 2.00 G (unit: 0.01 G)	
3	Moving amount designation	[▲], [▼]: Selects moving amount. Set value: 1 mm – media length (width) (unit: 1 mm) When media is not detected: 1 mm – Mechanical limit size	
4	Test start	[ENTER]: Repeats reciprocating motion in the X direction with designated conditions.	
5	End	[END]: Returns to the motion starting position and executes capping to end the test.	



During the test, heater temperature control is allowed. (When [HEATER] key is effective)

1

2

3

4

5

6

7

8

5.1.6 [MOTOR TEST] Y SERVO MOTOR

1.1

■ Function

Operation test of Y-axis motor is executed.

■ Operation Procedures

Step	Item	Description	Remarks
1	Speed designation	[▲], [▼]: Selects speed. Set value: 1 – 1500 mm/s (unit: 1 mm/s)	[◀], [▶]: Selection of item 2 – 4
2	Acceleration designation	[▲], [▼]: Selects acceleration. Set value: 0.05 – 2.00 G (unit: 0.05 G)	
3	Moving amount designation	[▲], [▼]: Selects moving amount. Set value: 1 mm – media length (width) (unit: 1 mm)	
4	Cap OFF		(Only after media detection)
5	Test start	[ENTER]: Repeats reciprocating motion in the Y direction with designated conditions.	
6	End	[END]: Returns to the motion starting position and executes capping to end the test.	



During the test, heater temperature control is allowed. (When [HEATER] key is effective)

1

2

3

4

5

6

7

8

5.1.7 [MOTOR TEST] XY SERVO MOTOR**■ Function**

Operation test of XY-axis motor is executed.

■ Operation Procedures

Step	Item	Description	Remarks
1	X speed designation	[▲], [▼]: Selects speed. Set value: 1 – 500 mm/s (unit: 1 mm/s)	[◀], [▶]: Selection of item 1 – 3
2	X acceleration designation	[▲], [▼]: Selects acceleration. Set value: 0.01 – 2.00 G (unit: 0.01 G)	[ENTER]: Transits to the Y direction setting (5 –).
3	X moving amount designation	[▲], [▼]: Selects moving amount. Set value: 1 mm – media length (unit: 1 mm) When media is not detected: 1 mm – Mechanical limit size Press [ENTER] to start Y-axis motor setting.	
4	Y speed designation	[▲], [▼]: Selects speed. Set value: 1 – 1500 mm/s (unit: 1 mm/s)	[◀], [▶]: Selection of item 4 – 6
5	Y acceleration designation	[▲], [▼]: Selects acceleration. Set value: 0.05 – 2.00 G (unit: 0.05 G)	[ENTER]: Transits to the following step.
6	Y moving amount designation	[▲], [▼]: Selects moving amount. Set value: 1 mm – media width (unit: 1 mm) When media is not detected: 1 mm – Mechanical limit size	[END]: Transits to the X direction setting (2 –).
7	Cap OFF		Only after media detection
8	Test start	[ENTER]: Repeats the following motion with the designated conditions. (During the motion, No. of Y reciprocation is displayed.) a) Moves by Y designated distance. b) Moves by X designated distance, and moves to Y starting position.	
9	End	[END]: Returns to the motion starting position and executes capping to end the test.	



During the test, heater temperature control is allowed. (When [HEATER] key is effective)

1

2

3

4

5

6

7

8

5.1.8 [MOTOR TEST] WIPER MOTOR

1.0

■ Function

Operation test of wiper motor is executed.

■ Operation Procedures

Step	Item	Description	Remarks
1	Driving speed designation	[▲], [▼]: Selects driving speed of the motor. Set value: 100 – 4000 pps (unit: 100 pps)	[◀], [▶]: Selection of item 1 – 3
2	WAIT designation	[▲], [▼]: Designates operation interval. Set value: 0 – 60 sec. (unit: 1 sec.)	
3	Count designation	[▲], [▼]: Designates No. of operation. Set value: CONTINUE, 1 – 1000 count (unit: 1 count)	
4	Test start	[ENTER]: Drives the motor with designated conditions. When CONTINUE is selected in count setting, press [END] to finish the test.	
5	End	Return the wiper to the original position.	

1**2****3****4****5****6****7****8**

5.1.9 [MOTOR TEST] PUMP MOTOR**■ Function**

Operation test of pump motor is executed.

■ Operation Procedures

Step	Item	Description	Remarks
1	Pump selection	[◀], [▶]: Selects pump by moving the cursor. [▲], [▼]: Selects operation.	[◀], [▶]: Selection of item 1-3
2	Rotation direction designation	[▲], [▼]: Selects pump rotation direction. Set value: FORWARD, REVERSE	
3	Driving speed designation	[▲], [▼]: Selects driving speed. Set value: 100-4000pps (unit: 100pps)	
4	Carriage/Motor state selection	[FUNCTION]: Carriage/motor state at test selection menu is displayed. <Carriage> IN: Executes at cap position. OUT: Executes after carriage out. <MOTOR> ON: Executes with Y-axis motor ON. OFF: Executes with Y-axis motor OFF.	
5	Test start	[ENTER]: Removes the cap and moves the carriage to maintenance position. Drives the pump motor with designated conditions. [END]: Ends the test.	During operation, open/close the cartridge valve with [FUNCTION].
6	End	Test is completed.	



Note that executing (FORWARD) while the cap is on causes vacuum suction.

1

2

3

4

5

6

7

8

■ **Function**

Operation test of take-up motor is executed.

■ **Operation Procedures**

Step	Item	Description	Remarks
1	Test start	[ENTER]: Drives take-up motor. (SW of winding device enables switching of winding direction or operation stop)	
2	Test end	[END]: Completes the test.	

1
2
3
4
5
6
7
8

5.1.11 [HEATER TEST] TEMPERATURE**■ Function**

Temperature tests of the media heater are executed.

■ Operation Procedures

Step	Item	Description	Remarks
1	Temperature setting	Sets temperature of Pre, Print, and After Heater to control the heater. Set value (Celsius): OFF, 20 – 50 °C (unit: 1°C) Set value (Fahrenheit): OFF, 68 – 122 °F (as converted from Celsius, unit is not °F)	
2	Temperature display	[ENTER]: Returns to temperature setting.	



- Temperature is displayed with a unit selected in the [UNIT SETUP] of the [MACHINE SETUP] function.
- A/D conversion value is also displayed.

1**2****3****4****5****6****7****8**

■ **Function**

ON/OFF test of heater is executed.

■ **Operation Procedures**

Step	Item	Description	Remarks
1	ON/OFF setting	Designates ON/OFF of Pre, Print and After Heater.	Temperature is not controlled.
2	ON/OFF display	[FUNCTION]:Returns to setting screen.	

	<ul style="list-style-type: none"> ● Temperature is displayed with a unit selected in the [UNIT SETUP] of the [MACHINE SETUP] function. ● A/D conversion value is also displayed.
---	---

1
2
3
4
5
6
7
8

5.1.13 ACTION TEST**■ Function**

Checks the operation of movable parts alone of the unit printer.

■ List of test items

Item	Description
VACUUM FAN	Description: Operation test of vacuum fan motor. Set value: L.L, LOW, MID, HIGH, OFF
Y-CUTTER	Description: Operation test of media cutter. Set value: UP, DOWN [FUNCTION]: Sets operation interval of Y-cutter. [▲], [▼]: Sets operation interval. Set value: 0 – 7200 sec. (unit: 1 sec) [ENTER]: Repeats UP and Down at the set interval. Number count is displayed during the execution.
LED POINTER	Description: Operation test of LED pointer. Set value: ON, OFF
HDC FAN	Description: Operation test of HDC fan. Set value: ON, OFF
DRY FAN & DEOD. FAN	Description: Optional operation test of dry/exhaust fan motor. (option) Set value: ON, OFF
PR SOLENOID	Description: The operation test of the solenoid that operates the clamp pressure changeover lever. Set value: ON, OFF (Carry out the test by connecting the cutter unit to connection unit. When the menu is initiated, the connection unit connects with the print head. Therefore, manually connect the cutter head with connection unit before starting the test.)
P.HEAD SOLENOID	Description: The operation test of the solenoid that retains the print head at the cap position. Set value: ON,OFF

1

2

3

4

5

6

7

8

5.1.14 SENSOR TEST

■ Purpose

To check if the each sensor of the instruments printer functions normally.

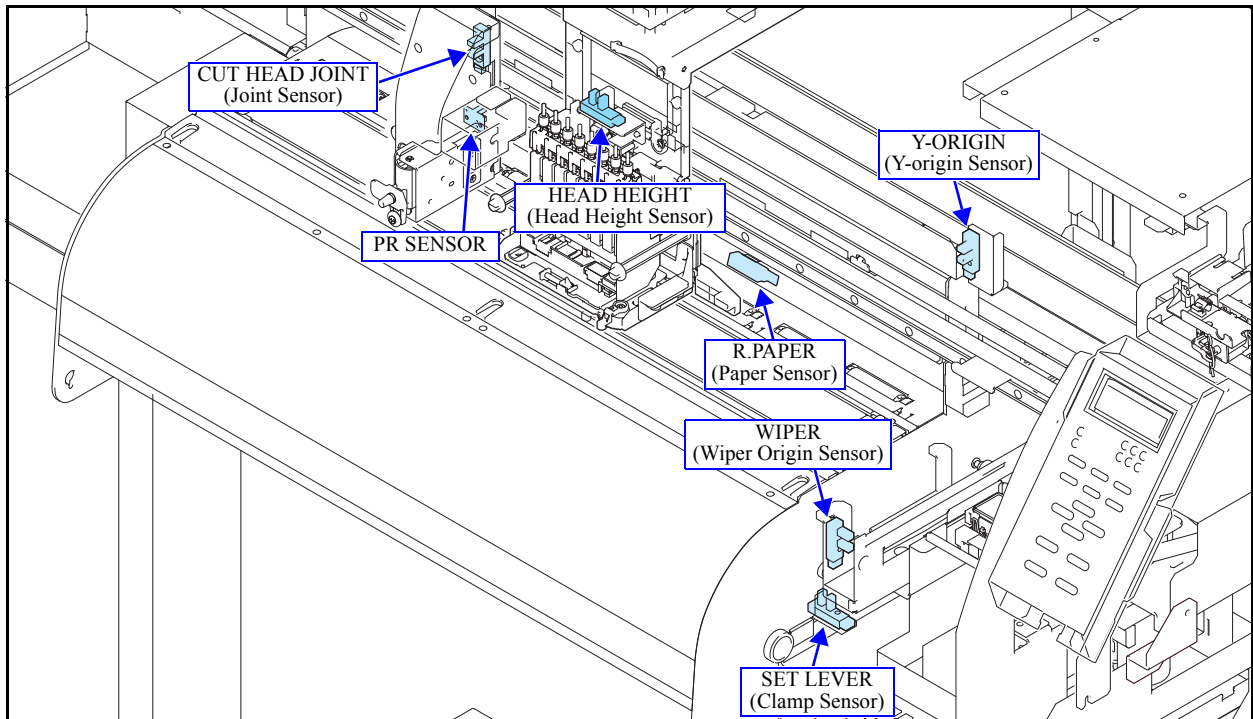

■ Function

Various sensors are tested. Before starting the test, the servomotor and stepping motor are turned off. After finishing the test, initial movement of original position detection is executed.

■ List of sensor test

No.	Item	Description	LCD display
1	SET LEVER	State display of clamp lever sensor	ON/OFF
2	R.PAPER	State display of rear paper sensor	ON/OFF
3	Y-ORIGIN	State display of Y origin sensor	ON/OFF
4	WIPER	State display of wiper sensor	ON/OFF
5	HEAD HEIGHT	State display of head height sensor	ON/OFF
6	PR SENSOR	Detects the position of the pinch roller.	ON/OFF
7	CUT HEAD JOINT	Checks the connection between the cut head carriage and connection unit.	ON/OFF
8	Main PCB ID	Judges the main PCB ID dedicated to CJV.	800 or more
9	Head Voltage	Measures the head voltage. If it is less than 800, there is a possibility of the malfunction of the head, leading to lowered voltage or fuse blowout.	800 or more



The condition of all the sensors is displayed on the screen by depressing [FUNCTION] during the time when the sensor test is selected.

(It is possible to display this screen by changing over any other screens.)

L=0 P=0 Y=x W=x C=0
H=0 PR=x CJ=x

Displayed in order of sensor test menu. ON=0. OFF=x
L: SET LEVER P: R.PAPER Y: Y-ORIGIN W: WIPER
H: HEAD HEIGHT PR: PR SENSOR CJ: CUT HEAD JOINT

1

2

3

4

5

6

7

8

5.1.15 OPTION

■ Function

Connection of all optional devices is checked.

“OFF” is displayed when not connected, and “ON” is displayed when the respective device is connected in the correct location.

■ List of options

LCD display	Options
REEL	Take-up device
EXH.	Exhaust fan
DRY	Dry fan



Since the shape of all the connectors is the same, they can be connected to any optional devices. However, if they are connected to the wrong devices, the devices will not work.

1

2

3

4

5

6

7

8

5.1.16 KEYBOARD LED

■ Function

ON/OFF test of the keyboard LEDs is executed.
The LEDs are controlled according to the ON/OFF designation.

■ List of LEDs

LED	Kinds
HEAT LED	Pre, Print, and After heat LEDs, Constant LED
PRINT MODE	Print mode LED
CUT MODE	Cut mode LED

1

2

3

4

5

6

7

8

5.1.17 KEYBOARD TEST

■ Function

Panel SW is tested.

When a panel SW is pressed, name of the SW is displayed on LCD.

When no key is pressed, "NONE" is displayed.

When [END] is pressed, "END TEST" is displayed and the keyboard test ends.

1**2****3****4****5****6****7****8**

Maintenance Manual > Test Items > Test Function > LCD TEST								Rev.
Model	CJV30/TPC	Issued	2008.08.04	Revised		F/W ver.	1.00	
5.1.18 LCD TEST								1.0

■ **Function**

Characters are displayed on LCD.

When the LCD Test is started, scrolling of character code of 0x21 – 0xFF in one line is repeated.
The test is completed by pressing [END].

1
2
3
4
5
6
7
8

5.1.19 TIMER CHECK

■ Function

Date and time of the device are confirmed or set.

Past date/time to be input is allowed max. 8 hours back from present time.

Inputting of other date/time becomes an error.

*Machine setting R Same as the time setting

Set value :20YY.MM.DD HH:MM:00

YY : 00 – 50

MM : 01 – 12

DD : 01 – 31

HH : 00 – 23

MM : 00 – 59

Returning to the last setting is allowed by pressing [FUNCTION] in the Date, Time Display State (not the Entering State). (However, the time elapsed after the setting change is added.)

1

2

3

4

5

6

7

8

5.1.20 MEMORY CHECK

■ Function

Variety of memory of the device is checked.

The memory check requires the following time. (1 count)

MAIN.SDRAM	: Approx. 12 min.
MAIN.F-ROM	: 1 Sec.
HEAD.EEPROM	: Approx. 22 sec.
32M SDRAM	: Approx. 120 sec.

■ List of memory checks

Item	Description
MAIN.SDRAM* ¹	<p>Read/Write check of SDRAM</p> <p>Select insert/not insert of wait time (30sec) between write and read of the data.</p> <p>In the checking, the following process is counted as 1 and is repeated until [END] is input.</p> <ol style="list-style-type: none"> 1. Write 00000000h onto all area of SDRAM starting from address 0. 2. Read vacant data starting from address 0 to all area of SDRAM sequentially to confirm that the readings meet the writing data. 3. Write FFFFFFFFh onto all area of SDRAM starting from address 0. 4. Read vacant data from address 0 to all area of SDRAM sequentially to confirm that the readings meet the writing data. 5. Write increment data of 00010203h, 04050607h, ... FCFDFE00h onto all area of SDRAM starting from address 0. 6. Read vacant data from address 0 to all area of SDRAM sequentially to confirm that the readings meet the writing data.
MAIN.F-ROM	<p>Hash check of F-ROM.</p> <p>In the checking, confirm that long word size SUM value from address 0 of F-ROM is 0001f000H*², that is counted as 1, and repeat the process until [END] is input.</p> <p>If the SUM value is not 0001f000H, the check process is discontinued and an error is displayed.</p>
HEAD.EEPROM* ¹	<p>Read/Write check of HEAD.EEPROM</p> <p>Select a head unit to be checked.</p> <p>Before starting the checking, save contents of EEPROM in S-RAM (head unit parameter area).</p> <p>In the checking, the following process is counted as 1 and is repeated until [END] is input.</p> <ol style="list-style-type: none"> 1. Write 00h onto HEAD.EEPROM starting from address 0 to confirm that read value is 00h 2. Write FFh onto HEAD.EEPROM starting from address 0 to confirm that read value is FFh. 3. Write increment data of 00h, 01h, 02h, ..., FDh, FEh, 00h, ... onto HEAD.EEPROM starting address 0 to confirm that read value agrees.
32M SDRAM	<p>Checking the write/read of SDRAM for receiving the cut data.</p> <p>Select insert/not insert of wait time (30sec) between write and read of the data.</p> <p>In the checking, the following process is counted as 1 and is repeated until [END] is input.</p> <ol style="list-style-type: none"> 1. Write 00000000h onto all area of SDRAM starting from address 0. 2. Read vacant data starting from address 0 to all area of SDRAM sequentially to confirm that the readings meet the writing data. 3. Write FFFFFFFFh onto all area of SDRAM starting from address 0. 4. Read vacant data from address 0 to all area of SDRAM sequentially to confirm that the readings meet the writing data. 5. Write increment data of 00010203h, 04050607h, ... FCFDFE00h onto all area of SDRAM starting from address 0. 6. Read vacant data from address 0 to all area of SDRAM sequentially to confirm that the readings meet the writing data.

Note: No. of counts is displayed during the check.

*1: When data does not agree, the check process is discontinued and memory address, write/read data at occurrence of the error are displayed.

*2: As sector 1 – 10 used by parameter are passed, SUM value is not 0.

1

2

3

4

5

6

7

8

■ **Function**

Skewing of media is checked.
When media is not detected, an OPERATION ERROR (ERROR30) is displayed.

Feed distance is designated to execute feeding.
Feed distance: 1–500 m (unit: 1 m)

During the feeding, remaining of feed distance is displayed with unit of 10 mm.

[END]: Aborts feeding, [ENTER]: Restarts feeding.

■ **Cut jig function**

After the Skew check starts (feed distance is not designated), the following operation starts the cut jig function.
[REMOTE] -> [FUNCTION]

The cut jig function repeats media cut → feed in feed distance and number of cut times designated.

Number of cut times is displayed in count down during cut.

Feed distance : 10–10000 mm (unit: 10mm, Default 500 mm)
Number of cut times : 1–1000 count (unit: 1count, Default 25 count)

1
2
3
4
5
6
7
8

Maintenance Manual > Test Items > Test Function > [TEMP.CHECK] HEAD TEMP.							Rev.
Model	CJV30/TPC	Issued	2008.08.04	Revised	F/W ver.	1.00	
5.1.22 [TEMP.CHECK] HEAD TEMP.							1.0

■ **Function**

Environment temperature of head is displayed (A/D value is also displayed).

A unit selected in the [UNIT SETUP] of the [MACHINE SETUP] is used in the display of head temperature.

1
2
3
4
5
6
7
8

Maintenance Manual > Test Items > Test Function > [TEMP.CHECK] NOZZLE TEMP.							Rev.
Model	CJV30/TPC	Issued	2008.08.04	Revised	F/W ver.	1.00	
5.1.23 [TEMP.CHECK] NOZZLE TEMP.							1.0

■ **Function**

Nozzle temperature error check is executed.

At Normal: OK is displayed.

At error: NG is displayed.

1

2

3

4

5

6

7

8

Maintenance Manual > Test Items > Test Function > [TEMP.CHECK] HEAT SINK TEMP.							Rev.
Model	CJV30/TPC	Issued	2008.08.04	Revised	F/W ver.	1.00	
5.1.24 [TEMP.CHECK] HEAT SINK TEMP.							1.0

■ **Function**

Temperature of HDC board heat sink is displayed (A/D value is also displayed).

A unit selected in the [UNIT SETUP] of the [MACHINE SETUP] is used in the display of heat sink temperature.

1
2
3
4
5
6
7
8

5.1.25 [TEMP.CHECK] SLIDER TEMP.

■ Function

Temperature read from the thermistor on the ink slider PCB assy is displayed (A/D value is also displayed).

1

2

3

4

5

6

7

8

5.1.26 LINEAR ENCODER

■ Function

Linear encoder scale and linear sensor are tested.

Move a carriage by the designated distance (3 reciprocations) to display the difference between linear encoder value and Y-axis motor encoder value. If an error arises during the operation, discontinue the test.

Moving distance: 100 mm – Maximum actual operation limit (unit: 100 mm)

LCD display is as follows:

(M*: Y-axis motor encoder, E*: linear encoder)

- Moving distance : M=****.* E=****.* (unit: 0.1 mm)
- Difference in encoder values between before and after moving : Mc=****.* Ec=****.* (unit: 0.1 mm)
- Encoder values before movement : Ms=***** Es=*****
- Encoder values after movement : Mm=***** Em=*****
- Encoder values after having moved by designated distance : Mr=***** Er=*****



Be careful about the carriage which moves in high speed to execute the scan.

1

2

3

4

5

6

7

8

5.1.27 [INK CARTRIDGE] PACK&END SENSOR

■ Function

The state of cartridge exist/non-exist sensor and end sensor is displayed.

A slot number on which an error (NO CARTRIDGE, INK NEAR END) is found is displayed.

(Example of LCD display)

PACK	1234 5678
END	1234 5678

1

2

3

4

5

6

7

8

Maintenance Manual > Test Items > Test Function > [INK CARTRIDGE] CARTRIDGE VALVE							Rev.
Model	CJV30/TPC	Issued	2008.08.04	Revised	F/W ver.	1.00	
5.1.28 [INK CARTRIDGE] CARTRIDGE VALVE							1.0

■ **Function**

Open/close of cartridge valve is checked.
 Executes all OPEN/all CLOSE of valves by depressing [FUNCTION] key.

1
2
3
4
5
6
7
8

5.1.29 [INK CARTRIDGE] INK-IC CHECK

■ Function

Ink cartridge IC is checked.

IC chip data is read and the number of error occurrence at each cartridge is displayed.

1

2

3

4

5

6

7

8

Maintenance Manual > Test Items > Test Function > [INK CARTRIDGE] CARTRIDGE LED								Rev.
Model	CJV30/TPC	Issued	2008.08.04	Revised	2008.09.17	F/W ver.	1.20	
5.1.30 [INK CARTRIDGE] CARTRIDGE LED								1.1

■ **Function**

On/Off of cartridge LED is tested.

Use [FUNCTION] to move the cursor in ERROR or ACTIVE status.

1

2

3

4

5

6

7

8

5.1.31 [WASH CARTRIDGE] PACK&END SENSOR

■ Function

The state of cartridge exist/non-exist sensor and end sensor is displayed.

(Example of LCD display)

```
#PACK&END SENSOR
PACK :ON      END:OFF
```

1

2

3

4

5

6

7

8

5.1.32 [WASH CARTRIDGE] CARTRIDGE VALVE

■ Function

Open/close of cartridge valve is checked.

1
2
3
4
5
6
7
8

Maintenance Manual > Test Items > Test Function > [WASH CARTRIDGE] IC CHECK							Rev.
Model	CJV30/TPC	Issued	2008.08.04	Revised	F/W ver.	1.00	
5.1.33 [WASH CARTRIDGE] IC CHECK							1.0

■ **Function**

Maintenance washing liquid cartridge IC is checked.

IC chip data is read and the number of error occurrence is displayed.

1
2
3
4
5
6
7
8

5.1.34 HEAD JOINT

■ Purpose

To test if the connection to the print head or the cutter head is normal

Check the operation by repeating the connection operation.

If an error occurs during the connection operation, carry out the test to find out the cause of the error.

■ Operation sequence of HEAD JOINT test

No.	Item	Description	Remarks
1	Test start	The connection/release operation of the cutter head or the print head is repeated according to the connection unit that moves right and left. In this case, ON/OFF operation of this head clamp is also executed. The connection and lock of the unit is judged by the following: The right side of main body: Linear encoder The left side of main body: Light shut-off plate The number of connections is expressed by COUNT=n.	
2	Test end		

■ Relevant errors

Error	Description	Parts to be checked
C-LOCK Error	Abnormal standby position of the cutter head	<ul style="list-style-type: none"> • P, C Solenoid • PR Sensor
P-LOCK Error	Abnormal standby position of the print head	<ul style="list-style-type: none"> • P, C Solenoid • PR Sensor
HEAD JOINT Error	Abnormal connection of C head	Joint Sensor

1

2

3

4

5

6

7

8

5.1.35 PINCH ROLLER**■ Purpose**

To check the changeover operation of the clamping pressure

■ Operation sequence of PINCH ROLLER test

No.	Item	Description	Remarks
1	Test start	[ENTER]:Starting the PINCH ROLLER test	
2	Selecting the clamping pressure and the order of changeover	Example of panel display: L>0>L>M>L>H [◀], [▶]: Selects the order of clamping pressure changeover. [▲], [▼]: Selects the clamping pressure (Applied to all the pinch rollers) Set value: H, M, L, O	
3	Selecting the number of pinch roller until which the clamping pressure is changed over.	Example of panel display: PINCH ROLLER No.7	
4	Start of test operation	[ENTER]: Starts operation.	
5	Test end	[END]: Test is completed.	

1**2****3****4****5****6****7****8**

5.1.36 [CUT PATTERN] TEST

Function

Plots the test patterns for plotting evaluation.
The size of the plots is automatically adjusted to the size of the media that is set.

Tests repeatability, paper slippage, etc.

Execute this function after having detected the media by the leaf.
Also, set the tool to "PEN".

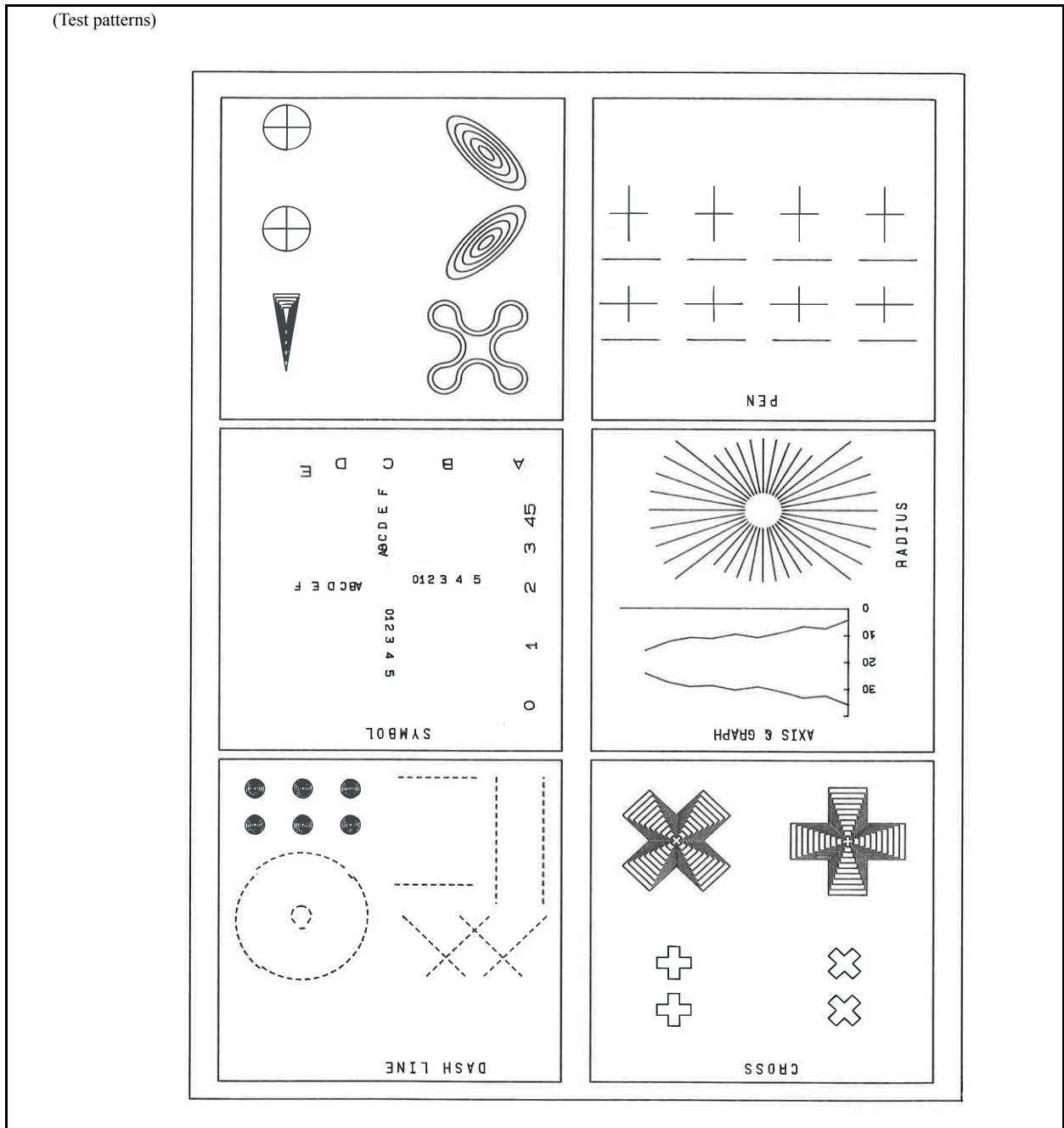

- 1
- 2
- 3
- 4
- 5
- 6
- 7
- 8

Set value

Number of Times: 0 to 99 (0 is for limitless loop)

5.1.37 [CUT PATTERN] 2m

■ Function

Cut a test pattern (2m /10m), and check for slippage, skew, etc. which can occur when a long sheet is fed.

Cutting conditions:

- Speed: 20 cm/s or more
- Pressure: 100 g or less
- Offset: 0.30 mm

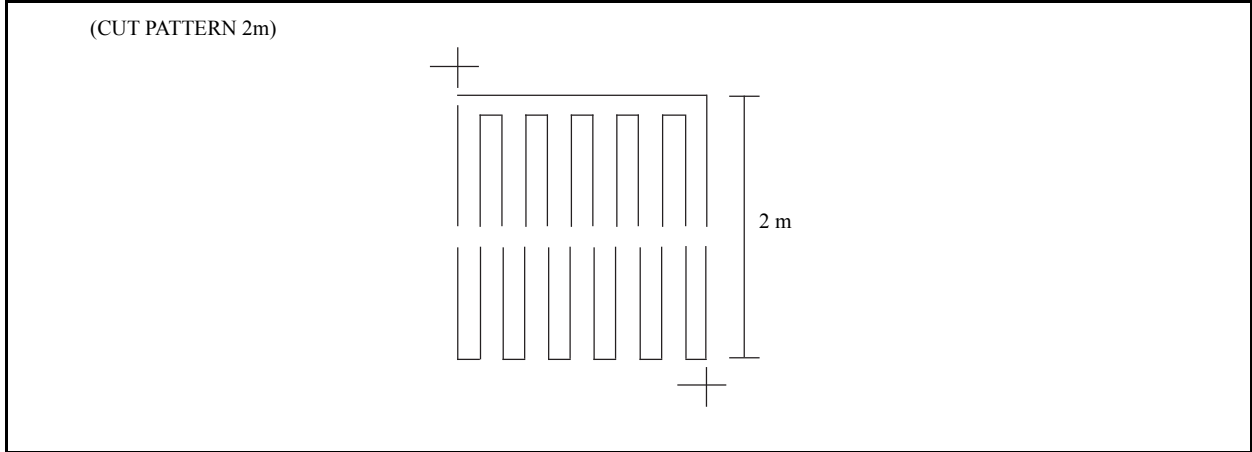

1

2

3

4

5

6

7

8

5.1.38 [CUT PATTERN] 10m**■ Function**

Cut a test pattern (10 m), and check for slippage, skew, etc. which can occur when a long sheet is fed.

Cutting conditions:

- Speed: 20 cm/s or more
- Pressure: 100 g or less
- Offset: 0.30 mm

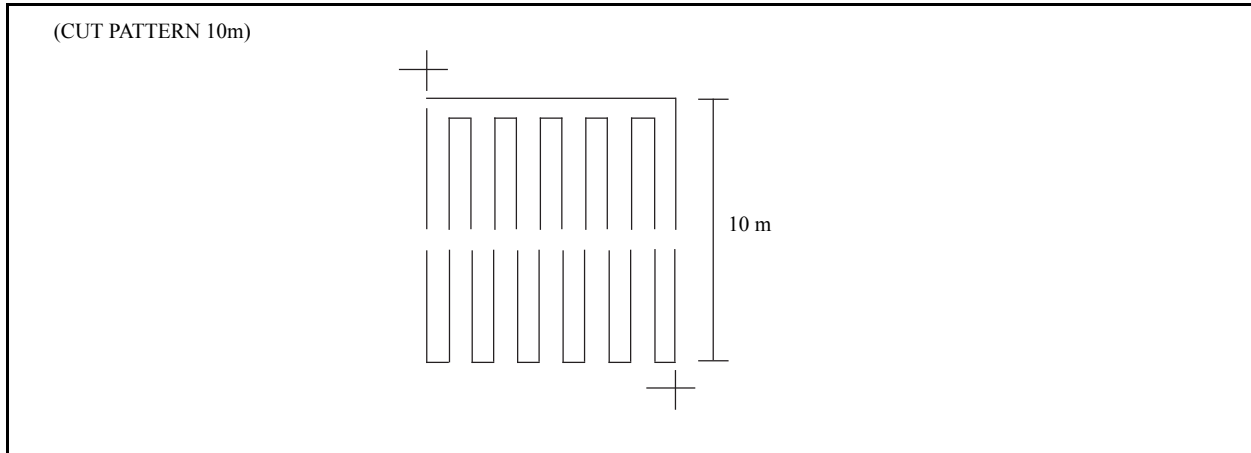
**1****2****3****4****5****6****7****8**

5.1.39 [CUT PATTERN] QUALITY

■ Function

Draws patterns to check the cut quality.

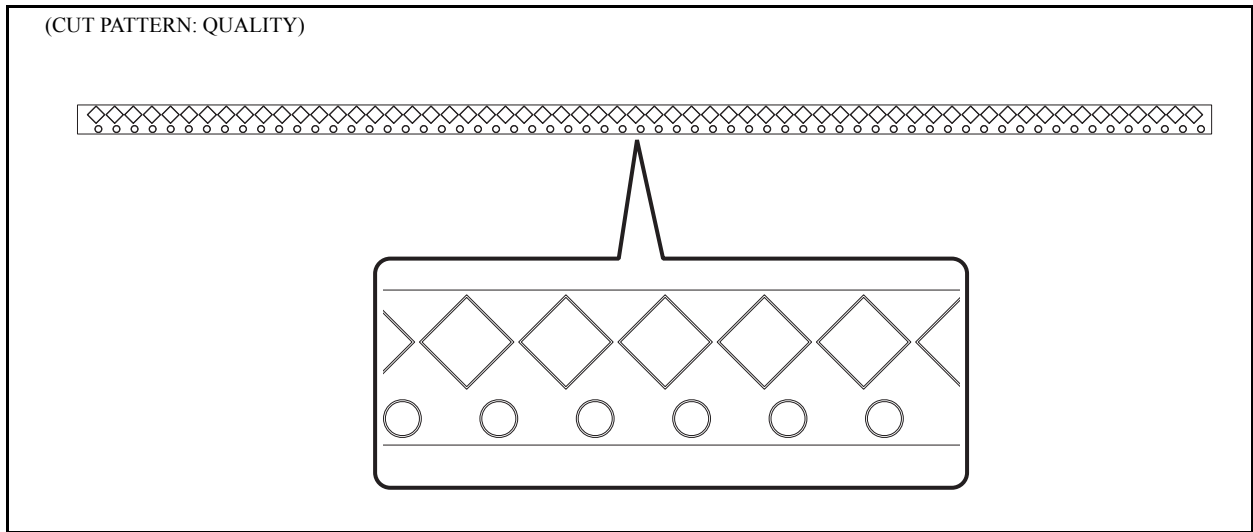

1

2

3

4

5

6

7

8

5.1.40 [CUT PATTERN] SQUARE

■ Function

Checks the cut quality.

The size and number of drawing can be changed.

Set value: 1 to 999 times

**1****2****3****4****5****6****7****8**

1

2

3

4

Test Items

**5.1
Test Function**

**5.2
Other Test**

5

6

7

8

5.2.1 Determining COM short circuit

■ Outline

Check whether the COM circuit generating part has electrical trouble or not.



After turning off the sub and main power switches in order, unplug the power code.

Check if no electric charge is remaining in the PCB.

Refer to the "4.5.2 Electric charge checking when replace the Electrical Parts"

It is very dangerous if sleep mode functions mistakenly during the operation.

Moreover, the PCB may be damaged in case electric charge still remains inside.

Also there is a possibility of electric shock because of high power voltage applied the high-pressure part of the power supply PCB assy. Take care to avoid contact with it.

■ Procedure

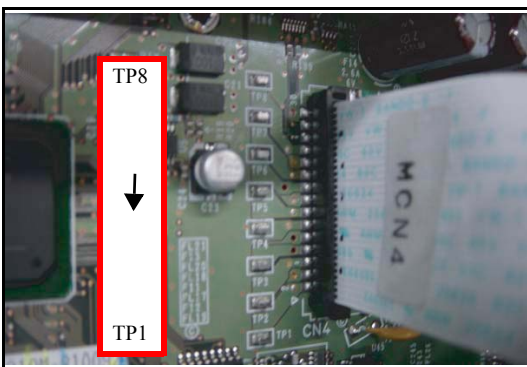

1. Measure a resistance between the test pin TP1 to TP8 and GND on the main PCB ASSY to determine the COM circuit condition. Connect the negative terminal of the tester to the GND test pin (GND1 to 9) and measure the resistance by getting the positive terminal touch to TP1 to 8.

Measured value of each test pin should be in the range of 17K ohms to 18K ohms.



If the machine cannot be turned on, it is highly possibility of impedance anomaly of the COM circuit and short circuit between 42V and GND in the main PCB. If all the measured value of the TP is shown in the abnormal range, compare with the measured value of the normal circuit board since it may be variation of the tester.

1

2

3

4

5

6

7

8

5.2.2 Checking Damage of the Print Heads

■ Outline

Check whether the COM line between the print head and the slider PCB has trouble or not.



After turning off the sub and main power switches in order, unplug the power code.

Check if no electric charge is remaining in the PCB.

Refer to the "4.5.2 Electric charge checking when replace the Electrical Parts"

It is very dangerous if sleep mode functions mistakenly during the operation.

Moreover, the PCB may be damaged in case electric charge still remains inside.

Also there is a possibility of electric shock because of high power voltage applied the high-pressure part of the power supply PCB assy. Take care to avoid contact with it.

■ Procedure

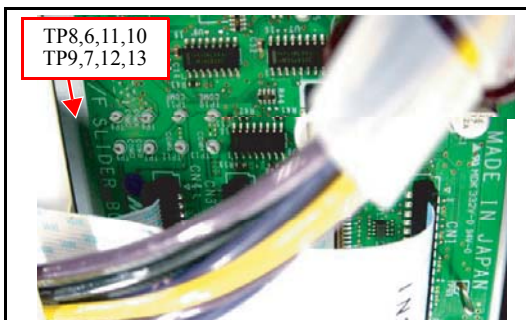
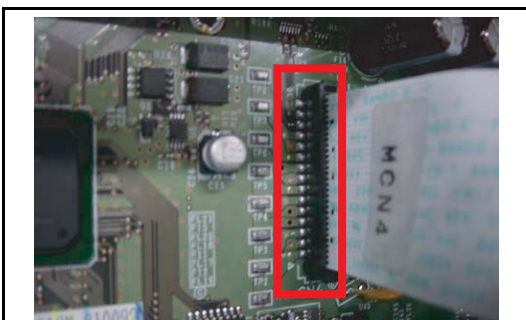

1. Release the locks on both sides of the HDC_FFC ASSY connected to CN1 to CN4 on the main PCB ASSY. And then pull out the HDC_FFC ASSY.

2. Measure a resistance between the test pin TP6 to 13 and GND on the ink slider PCB to determine the value. Connect the negative terminal of the tester to the GND test pin (TPG 1 to 5) and measure the resistance by getting the positive terminal touch to TP6 to 13.

Measured value of each test pin should be more than 10M ohms.



If any of the head COM line defect is found, the print head may be broken. Replace the print heads first. Connecting the normal main PCB without replacing the broken head will break the PCB continuously.

1

2

3

4

5

6

7

8

5.2.3 Checking Damage of the Main PCB ASSY

■ Outline

Check whether the COM circuit on the main PCB ASSY has trouble or not.



After turning off the sub and main power switches in order, unplug the power code.

Check if no electric charge is remaining in the PCB.

Refer to the "4.5.2 Electric charge checking when replace the Electrical Parts"

It is very dangerous if sleep mode functions mistakenly during the operation.

Moreover, the PCB may be damaged in case electric charge still remains inside.

Also there is a possibility of electric shock because of high power voltage applied the high-pressure part of the power supply PCB assy. Take care to avoid contact with it.

■ Procedure

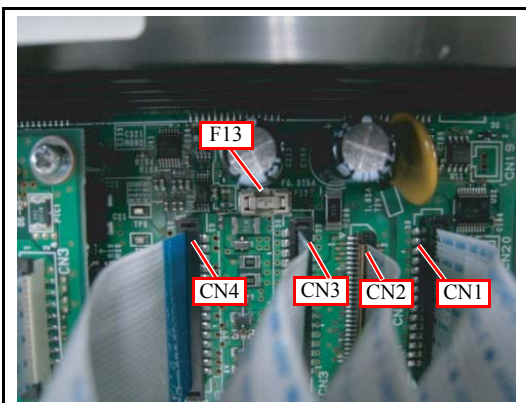

1. Release the locks on both sides of the connector for HDC_FFC ASSY connected to CN1 to CN4 on the main PCB ASSY. And then pull out the HDC_FFC ASSY.

2. Check the COM circuit referring to [5.2.1].

3. Measure the resistance on both ends of F13 (fuse) to check the blown fuse.

Measured value of the fuse should be less than 5 ohms.



If ERROR 205 [47V HEAD VOLTAGE] occurs, F13 (fuse) may be blown.

1

2

3

4

5

6

7

8

5.2.4 Checking Damage of the Ink Slider PCB

■ Outline

Check whether the IC on the ink slider PCB has electrical trouble or not.



After turning off the sub and main power switches in order, unplug the power code.

Check if no electric charge is remaining in the PCB.

Refer to the "4.5.2 Electric charge checking when replace the Electrical Parts"

It is very dangerous if sleep mode functions mistakenly during the operation.

Moreover, the PCB may be damaged in case electric charge still remains inside.

Also there is a possibility of electric shock because of high power voltage applied the high-pressure part of the power supply PCB assy. Take care to avoid contact with it.

■ Procedure

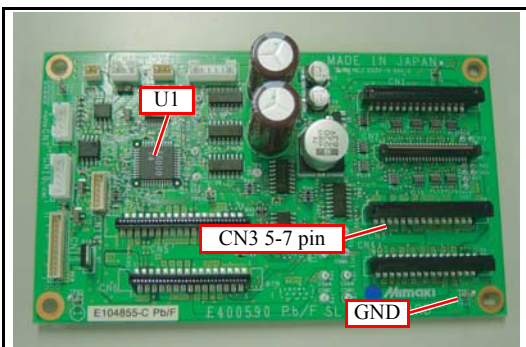

1. Remove the six FFCs at CN1 to CN6 on the ink slider PCB.

2. Measure a resistance between 3.3V pattern and GND pattern on the ink slider PCB to determine the condition. Connect the negative terminal of the tester to the GND test pin (TPG1 to 4) and measure the resistance by getting the positive terminal touch to 5-7 pin of CN3.

Measured value of each test pin should be more than 5K ohms.



If ERROR 200 or ERROR 50 occurs after the print heads replaced, U1 (CPLD, E600074) of the ink slider PCB may be damaged.

1

2

3

4

5

6

7

8

5.2.5 Checking Conduction of HDC FFC COM Line

■ Outline

Check whether the HDC FFC COM line has disconnection or poor contact or not.



After turning off the sub and main power switches in order, unplug the power code. Check if no electric charge is remaining in the PCB. Refer to the "4.5.2 Electric charge checking when replace the Electrical Parts" It is very dangerous if sleep mode functions mistakenly during the operation. Moreover, the PCB may be damaged in case electric charge still remains inside. Also there is a possibility of electric shock because of high power voltage applied the high-pressure part of the power supply PCB assy. Take care to avoid contact with it.

Signal	Test pin on the ink slider PCB	Test pin on the main PCB	Normal conduction	Nozzle line
COM-A	TP6	TP1	Less than 3 ohms	A*
COM-B	TP7	TP2	Less than 3 ohms	B*
COM-C	TP8	TP3	Less than 3 ohms	C*
COM-D	TP9	TP4	Less than 3 ohms	D*
COM-E	TP10	TP5	Less than 3 ohms	E*
COM-F	TP11	TP6	Less than 3 ohms	F*
COM-G	TP12	TP7	Less than 3 ohms	G*
COM-H	TP13	TP8	Less than 3 ohms	H*

* See below about nozzle lines.

■ 4-color ink set

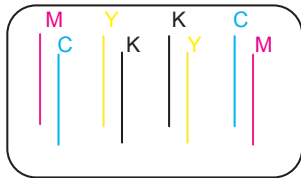

A line C line E line G line
B line D line F line H line

■ 6-color ink set

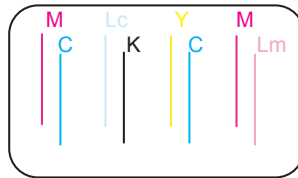

A line C line E line G line
B line D line F line H line

■ 6-color + white ink set

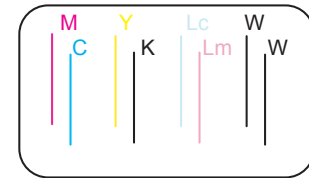

A line C line E line G line
B line D line F line H line

■ 7-color ink set

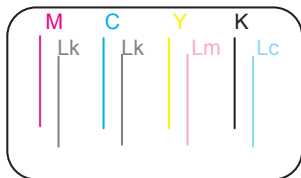

A line C line E line G line
B line D line F line H line

■ 8-color ink set

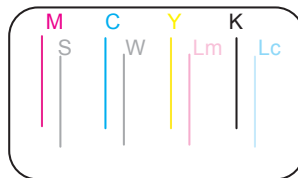

A line C line E line G line
B line D line F line H line

1

2

3

4

5

6

7

8

5.2.5 Checking Conduction of HDC FFC COM Line

■ Procedure

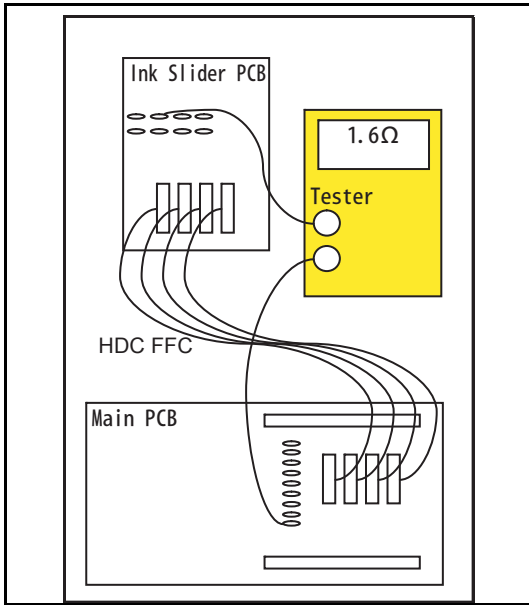

1. Check the conduction of HDC FFC COM line as the figure on the left.



The resistance undergoes a little bit change with the probe location or temperature.

1

2

3

4

5

6

7

8

5.2.6 Checking Conduction of HDC FFC Data Line

1.1

■ Outline

Check whether the HDC FFC data line has disconnection or poor contact or not.



After turning off the sub and main power switches in order, unplug the power code.

Check if no electric charge is remaining in the PCB.

Refer to the "4.5.2 Electric charge checking when replace the Electrical Parts"

It is very dangerous if sleep mode functions mistakenly during the operation.

Moreover, the PCB may be damaged in case electric charge still remains inside.

Also there is a possibility of electric shock because of high power voltage applied the high-pressure part of the power supply PCB assy. Take care to avoid contact with it.

Signal	IC pin on the ink slider PCB	IC pin on the main PCB	Normal conduction	Nozzle line
SID1+	U8-(10)	U46-(2)	Less than 22ohms	A*
SID1-	U8-(9)	U46-(3)	Less than 22ohms	
SID2+	U8-(14)	U46-(6)	Less than 22ohms	B*
SID2-	U8-(15)	U46-(5)	Less than 22ohms	
SID3+	U8-(2)	U46-(10)	Less than 22ohms	C*
SID3-	U8-(1)	U46-(11)	Less than 22ohms	
SID4+	U8-(6)	U46-(14)	Less than 22ohms	D*
SID4-	U8-(7)	U46-(13)	Less than 22ohms	
SID5+	U9-(10)	U47-(2)	Less than 22ohms	E*
SID5-	U9-(9)	U47-(3)	Less than 22ohms	
SID6+	U9-(14)	U47-(6)	Less than 22ohms	F*
SID6-	U9-(15)	U47-(5)	Less than 22ohms	
SID7+	U9-(2)	U47-(10)	Less than 22ohms	G*
SID7-	U9-(1)	U47-(11)	Less than 22ohms	
SID8+	U9-(6)	U47-(14)	Less than 22ohms	H*
SID8-	U9-(7)	U47-(13)	Less than 22ohms	

*See below about nozzle lines.

■ 4-color ink set

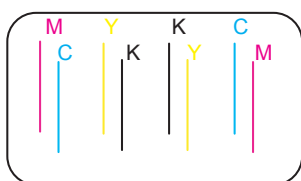

A line C line E line G line
B line D line F line H line

■ 6-color ink set

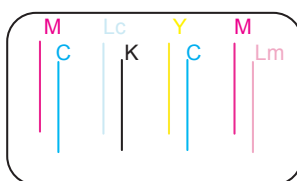

A line C line E line G line
B line D line F line H line

■ 6-color + white ink set

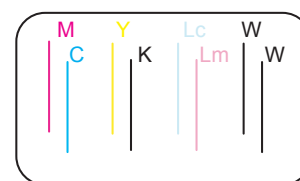

A line C line E line G line
B line D line F line H line

■ 7-color ink set

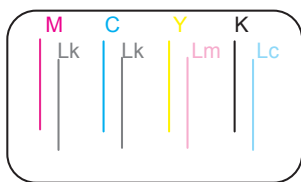

A line C line E line G line
B line D line F line H line

■ 8-color ink set

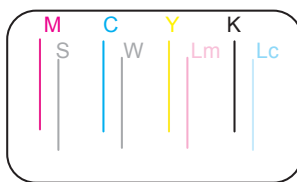

A line C line E line G line
B line D line F line H line

1

2

3

4

5

6

7

8

5.2.6 Checking Conduction of HDC FFC Data Line

■ Procedure

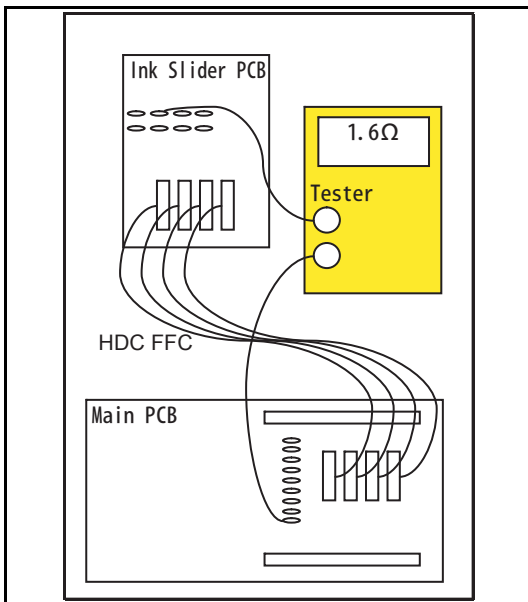

1. Check the conduction of HDC FFC data line as the figure on the left.



The resistance undergoes a little bit change with the probe location or temperature.

1

2

3

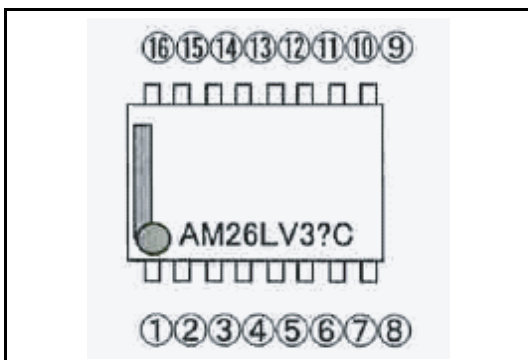

2. See the figure on the left for the IC pin number. The mark side is the start of the number.

4

5

6

7

8

1

2

3

4

5

Disassembly and Reassembly

6

**6.1
Covers**

**6.2
Ink-related Parts**

**6.3
Cut Head Carriage**

**6.4
Drive System**

**6.5
Electrical Parts**

**6.6
Sensors**

7

8

6.1.1 Cover Layout

■ Printer Front

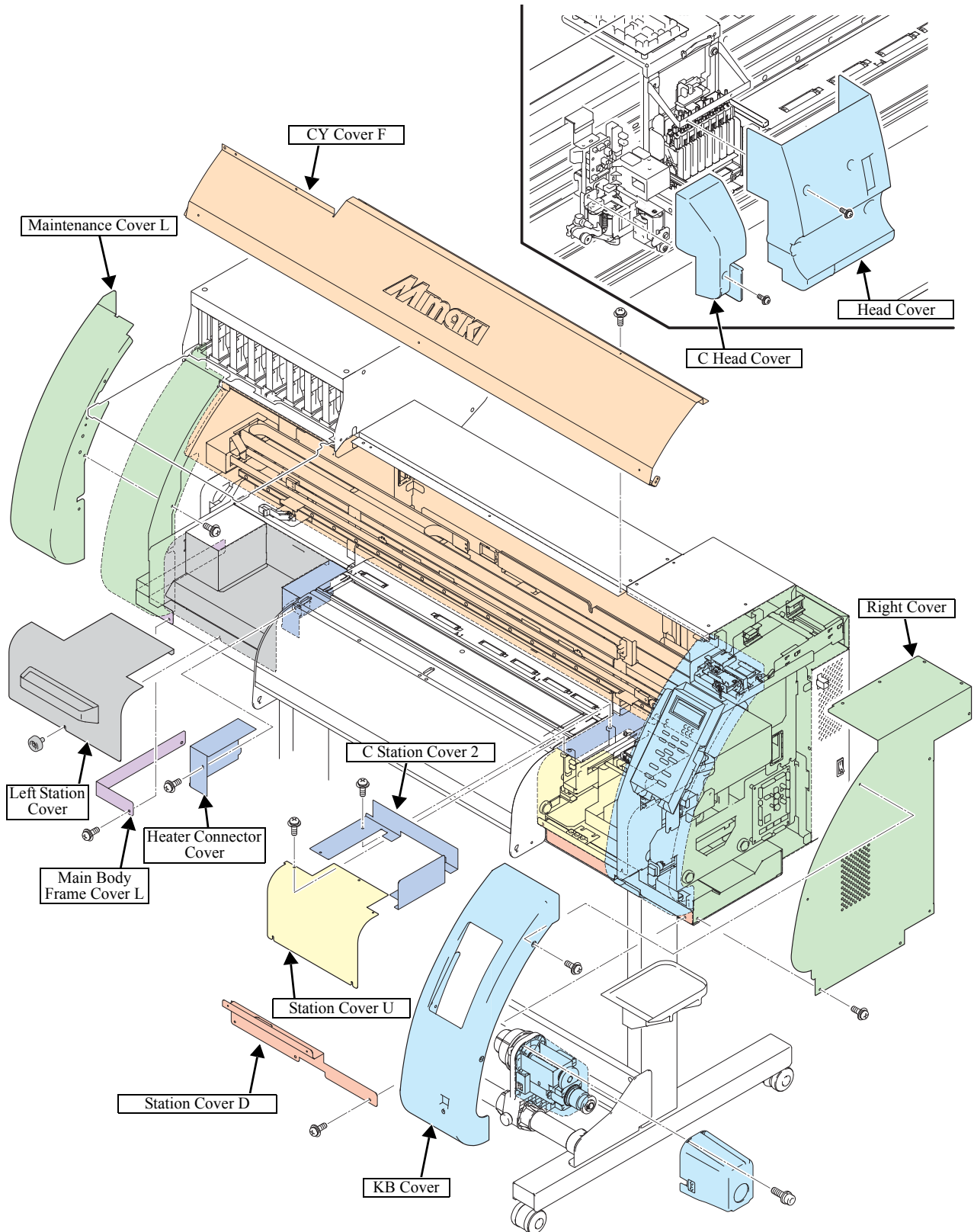

1

2

3

4

5

6

7

8

6.1.1 Cover Layout

■ Printer Rear

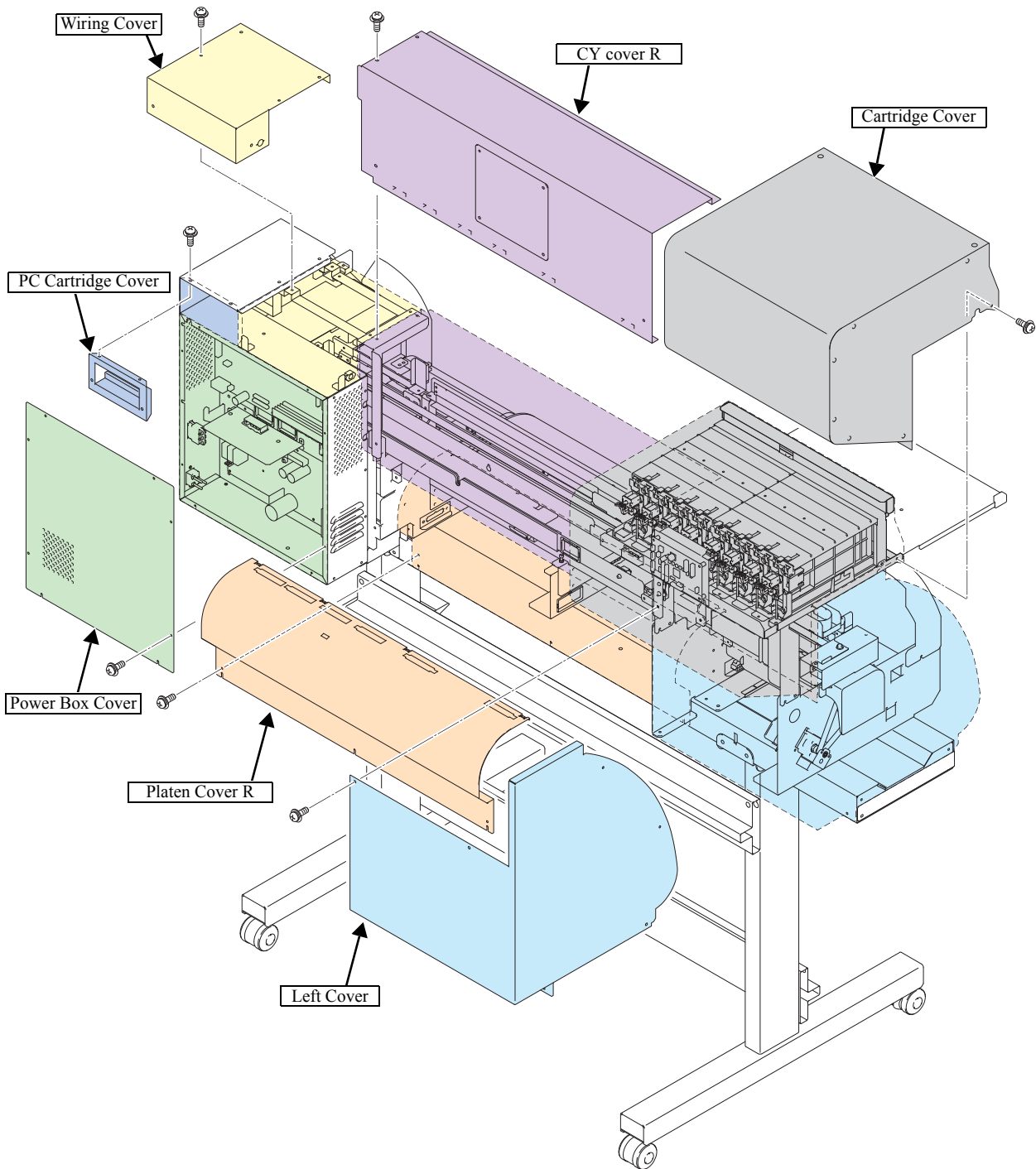

1

2

3

4

5

6

7

8



When fixing the cover, put it inside of the washer of loosened screw and tighten the screw.



Good example:

The washer of the screw is outside of the cover.



Bad example:

The washer of the screw is inside of the cover.

1

2

3

4

5

Disassembly and Reassembly

6

6.1 Covers	6.2 Ink-related Parts	6.3 Cut Head Carriage
6.4 Drive System	6.5 Electrical Parts	6.6 Sensors

7

8

6.2.1 Cleaning the inside of Head Unit

■ Outline

Since a water-based transportation liquid (S-46) is contained in the head on factory shipment, this will react with the solvent ink to form a precipitate.

Therefore, cleaning the inside of head unit with the solvent-washing liquid (MS washing liquid) is necessary before a new head is installed.



Use protection glasses and gloves during works.

Depending on the working condition, ink may reach your eyes or your skin may be roughed due to ink.

■ Work procedures



1. Remove **damper assy** from cleaning Jig in the head.
2. Charge Syringe with 12-16 cc of the washing liquid exclusively used when replacing the S head.

Types of wash

The washing liquid exclusively used when replacing the S head:
M005026



3. Fit **S-damper assy** again with syringe.
4. Insert it into Damper Connector on Head.



Be careful of the washing liquid, used for replacing the S head (M005026), dripping when taking out and putting in the damper. Especially, dripping on the FPC connector may damage the head.

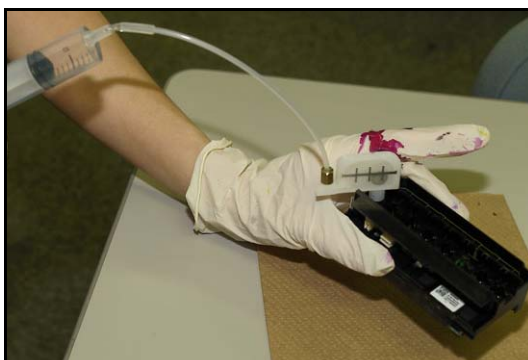

5. Slowly pour the washing liquid.

Pour 3 to 4 CD of the MS washing liquid into each nozzle in about 30 seconds.



Pour the washing liquid slowly, or the Head may be damaged.

6. Use waste cloth to hold the liquid that spills out of nozzle.



Do not touch the waste cloth to the nozzle surface, nor rub it with the waste cloth. Both may cause discharge failure.

* Conduct the aboves for every nozzle (x8).

(Charge the syringe with washing liquid through each inlet of 4 nozzles.)

6.2.2 Removing of Head Unit

■ Work procedures



1. Pull out the **head FFC assy** and **head memory cable assy** from the **ink slider PCB assy** through the top where the wiring cover removed.

2. Move the print head carriage onto the platen to make your work easy.

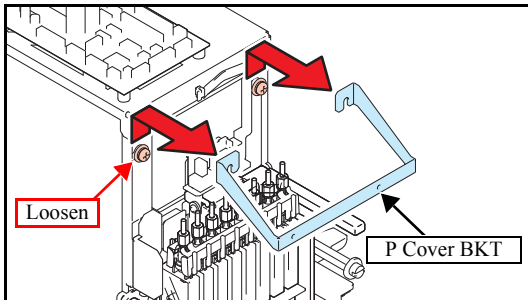

3. Loosen the screws at two locations on the right and left to remove the **P cover BKT**.

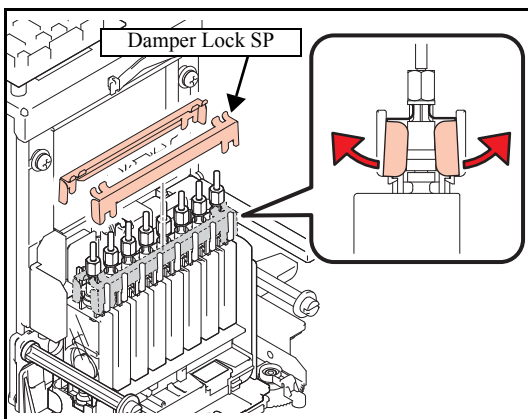

4. Remove **damper lock SPs**.

Near side: Rotate right and left edges towards you and remove them.

Rear side: Rotate right and left edges to the rear and remove them.

5. Place the waste cloth around the head unit so as not to contaminate the platen.

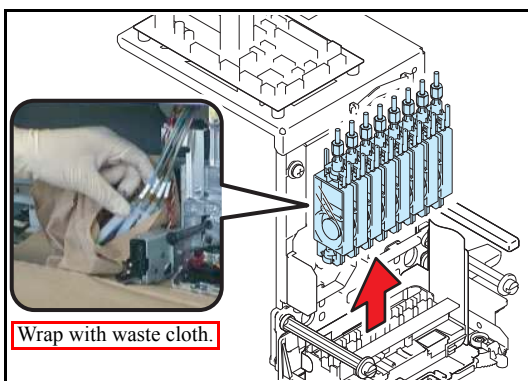

6. Pull out all **pressure damper SP assys** from the print head carriage and wrap them with the waste cloth so as not to contaminate their surroundings.



Do not touch the film of the damper assy.

1

2

3

4

5

6

7

8

6.2.2 Removing of Head Unit

1.0

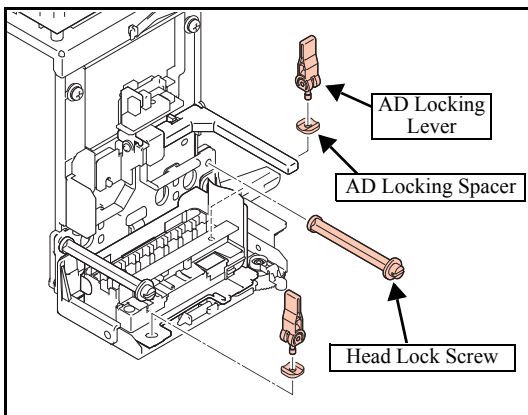

7. Unscrew the right **head lock screw**, and remove the **AD locking levers** located on the near left towards you and at the right recess.

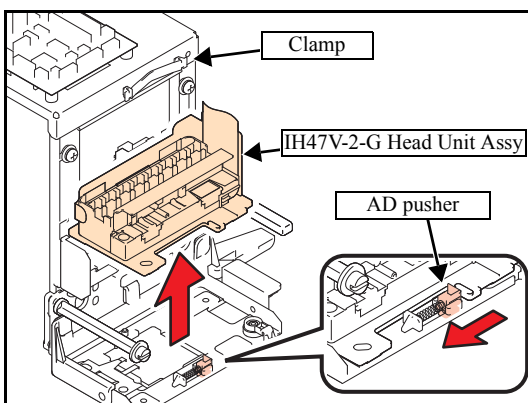

8. Remove the clamp of the **head FFC assy**. While moving the AD pusher to the left, pull directly up the **IH47V-2-G head unit assy** and remove it.

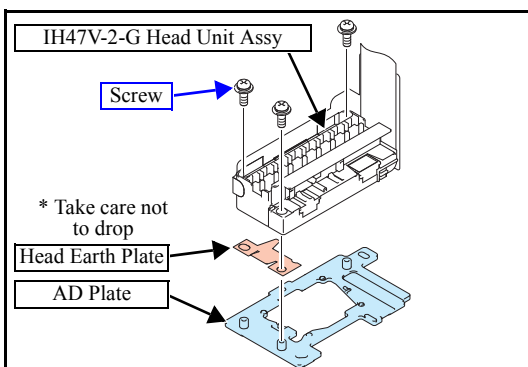

9. Remove the screws and then the **AD plate** from the **IH47V-2-G head unit assy**.



Take care for the head earth plate not to drop between the print head and the AD plate.

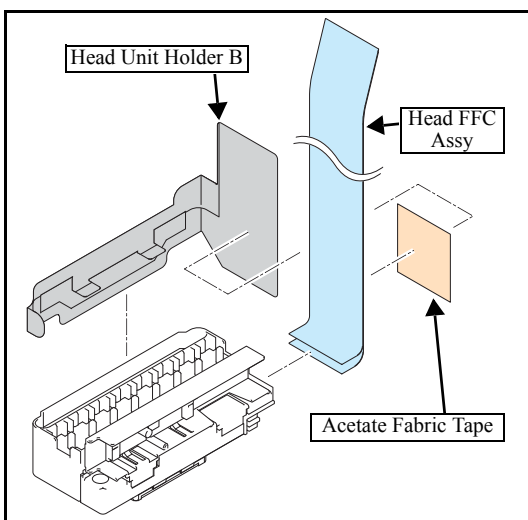

10. Remove **head unit holder B** and then the FFC and the head memory cable from the connector.

6.2.3 Mounting of Head Unit

■ Work procedures

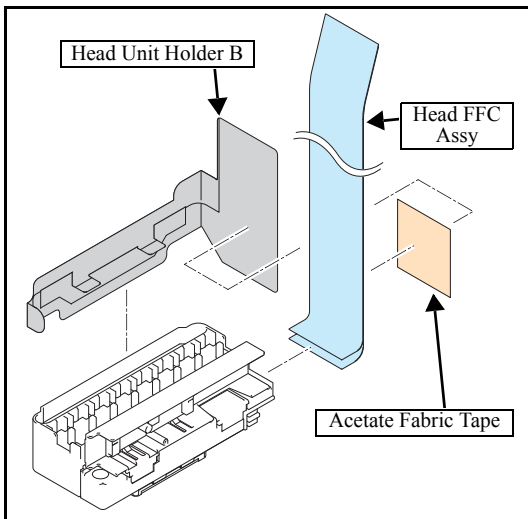

If entering the head ID manually, note it in advance. (Normally, you do not need to do it because of automatic writing.)

1. Bond the **head unit holder B** with the **head FFC assy** and the **head memory cable** together using the **acetate fabric tape** and mount it on **IH47V-2-G head unit assy**.



Since it is difficult to mount the head memory cable after FFC has been already taped, tape the head memory cable and FFC together.

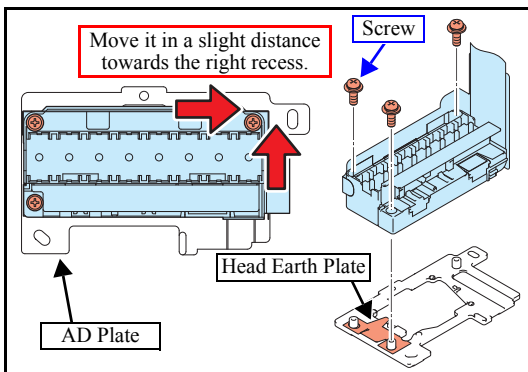

2. Insert the **head earth plate** in the **AD plate** and clamp three screws under the condition of lightly pushing the **IH47V-2-G head unit assy** towards the right recess.



- Do not touch the nozzle surface.
- The washing liquid must not attach to the head FFC.
- Do not push the head strongly because it becomes distorted to influence printing quality.

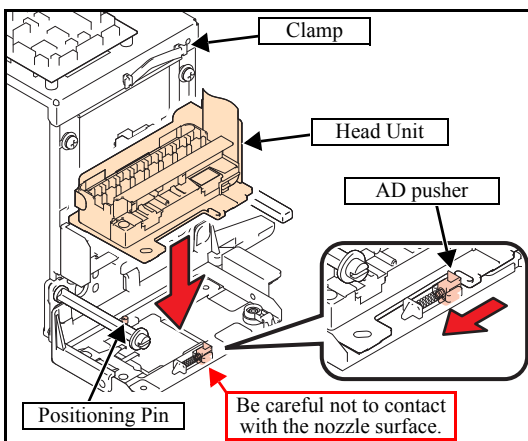

3. Position the **IH47V-2-G head unit assy** using the **positioning pin** at a recess, **AD pusher** on the near side towards you, and tilt adjusting jig, and mount the unit assy on the slider.



Take care for the nozzle surface not to touch the AD pusher.

4. Hold the **head FFC assy** and the **head memory cable** and cable with a clamp.

1

2

3

4

5

6

7

8

6.2.3 Mounting of Head Unit

1.0

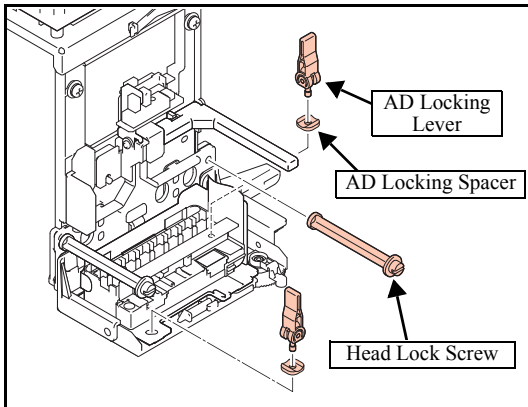

5. Pay attention to the direction of the **AD locking spacer** and tighten the left and right **AD locking levers**.

Left: Set the depression towards the front.

Right: Set the depression sideways.



Tighten the AD locking lever to a certain degree and go it down for locking.
At this time, if tightened too weakly, the lever cannot be locked, and if it is tightened too strongly, the AD locking spacer may crack. Proceed carefully with work.

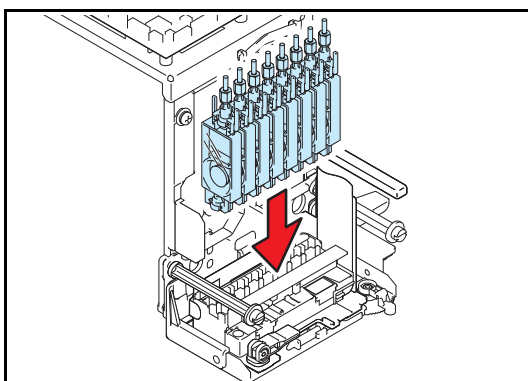

6. Mount the right **head lock screw**.

7. Insert the **pressure damper SP assy** in the order described on the tab.

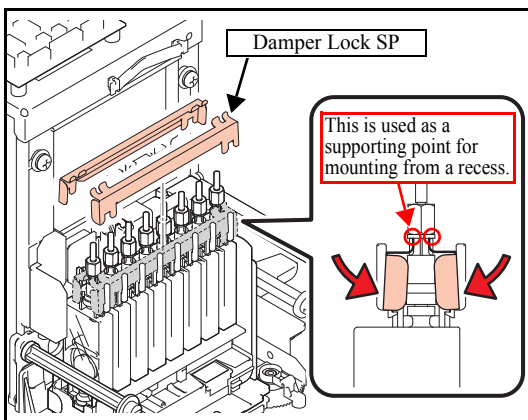

8. Mount the **damper lock SP** from a recess.



If the connection of the damper is loosened, the damper lock will not work. Make sure that no loose connection exists.

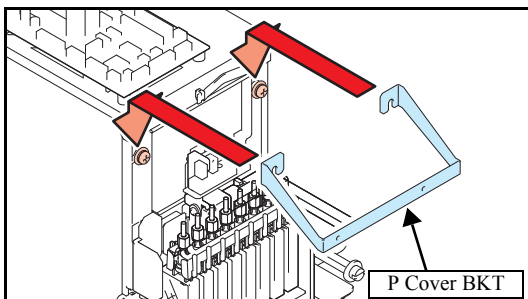

9. Mount the **P cover BKT** and tighten the right and left screws.

10. Connect the head FFC assy and head memory cable assy to the **ink slider PCB assy**.

1

2

3

4

5

6

7

8

6.2.4 Pump Motor

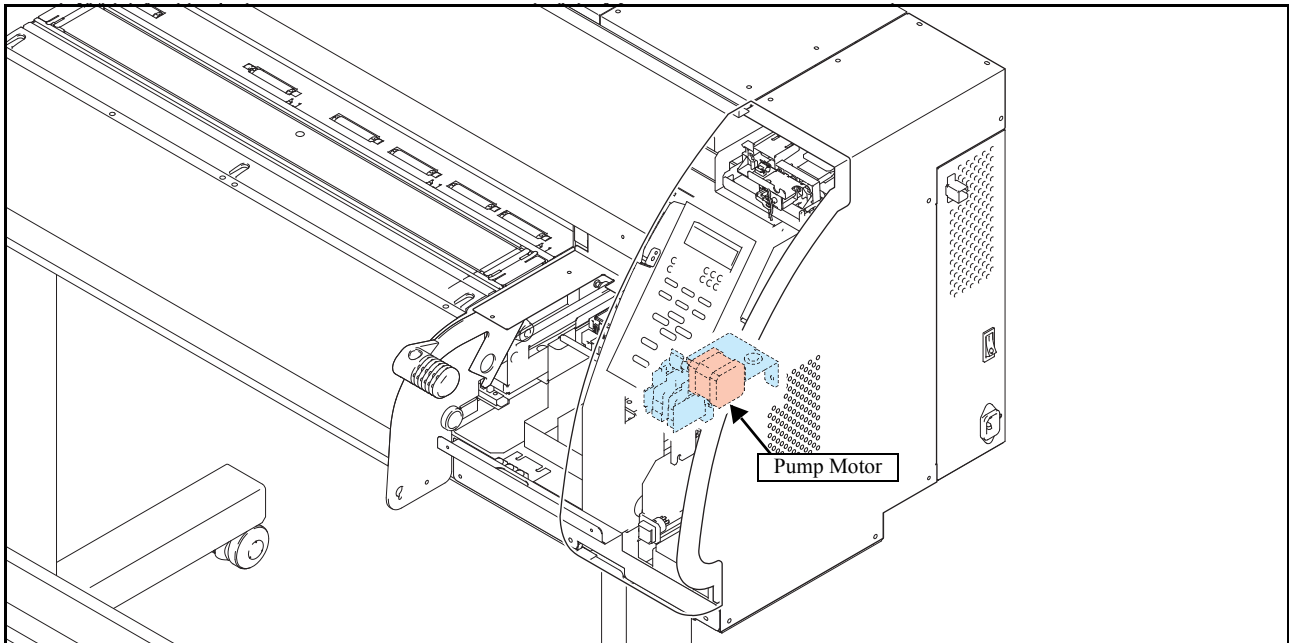

1

2

3

■ Work procedures

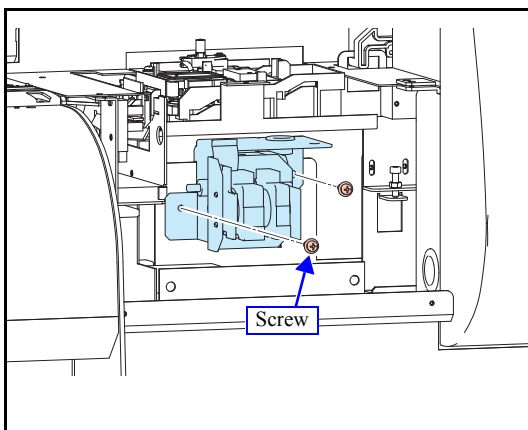

1. Remove the **station cover U**.
2. Remove the pump tube connected to the cap head.



Take care not to pollute the surroundings with waste ink or washing liquid.

4

3. Remove the pump motor assy connector and then **stepping motor assy** together with the **pump assy**.

5

4. Remove the **stepping motor**.

6

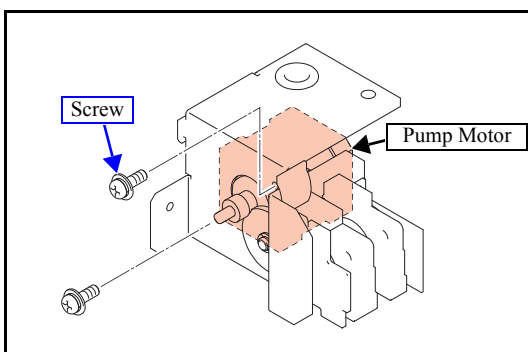

7

5. Reverse the disassembly procedure for reassembly.
Protrude the pump tube of the discharge side from tube end by 5 to 9 mm.

8

6.2.5 Pump Assy

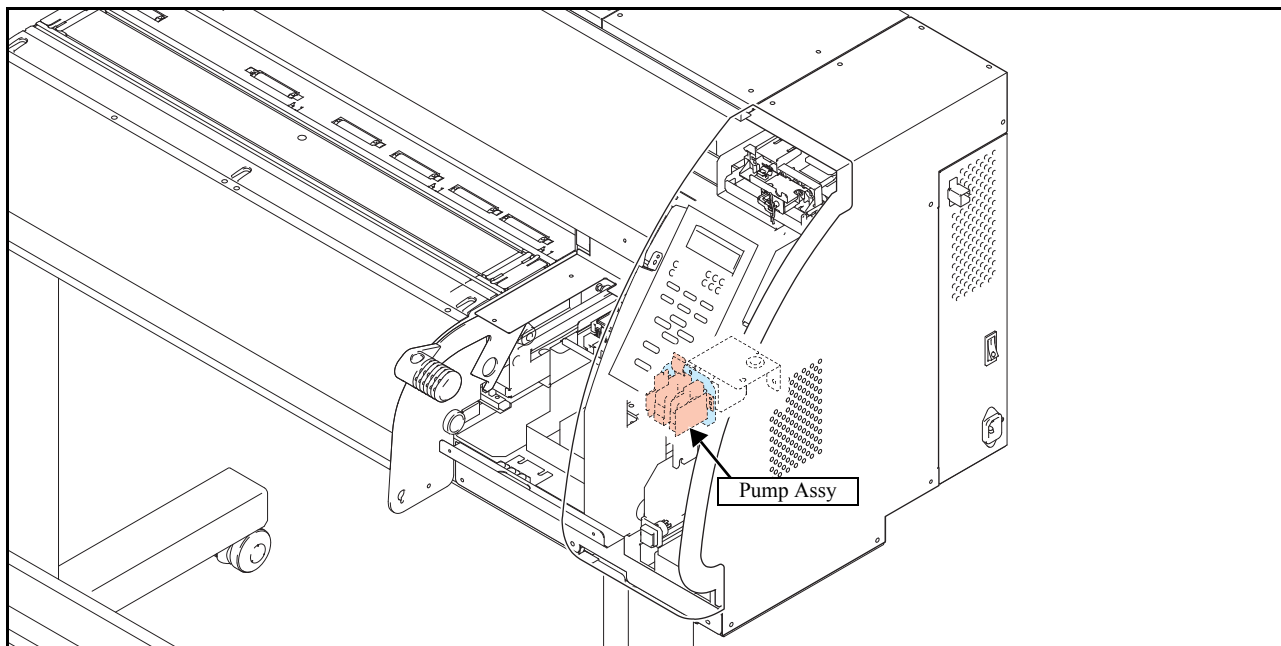

■ Work procedures

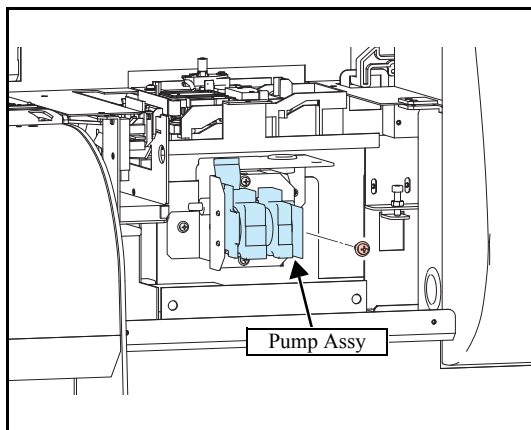

1. Remove the **station cover U**.
2. Remove the pump tube connected to the CP coupler.



Take care not to pollute the surroundings with waste ink or washing liquid.

3. Remove the **pump assy** from the **pump BKT**.

4. Reverse the disassembly procedure for reassembly.
Protrude the pump tube of the discharge side from tube end by 5 to 9 mm.

1

2

3

4

5

6

7

8

6.2.6 Cap Assy

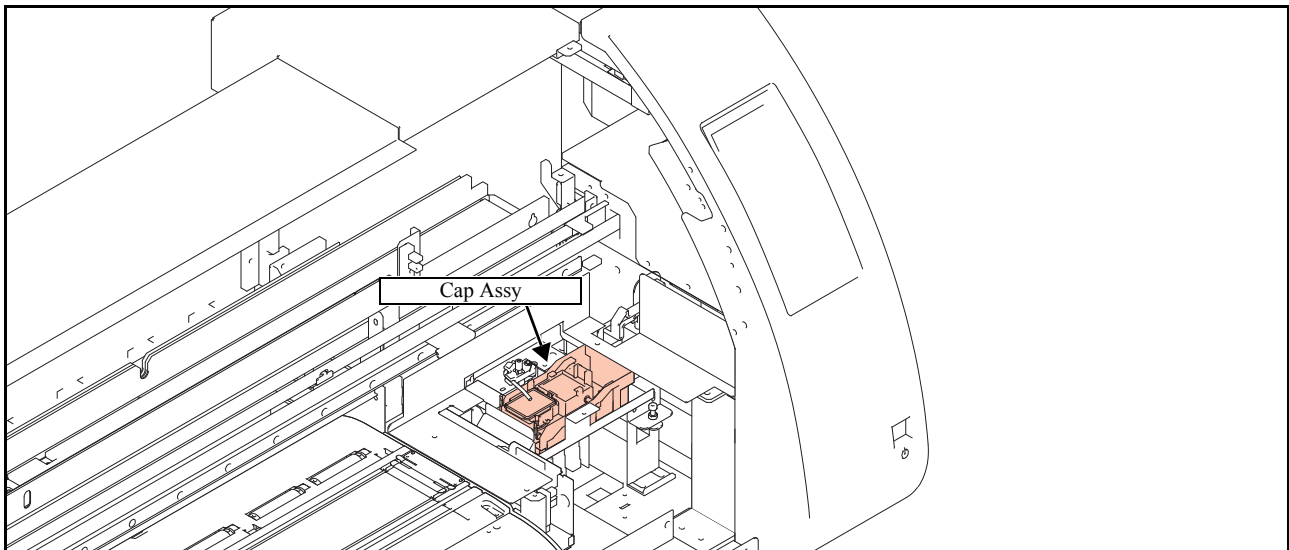

1

2

3

4

5

6

7

8

Work procedures



Be sure to turn off the main circuit breaker to prevent unexpected movements of the printer.

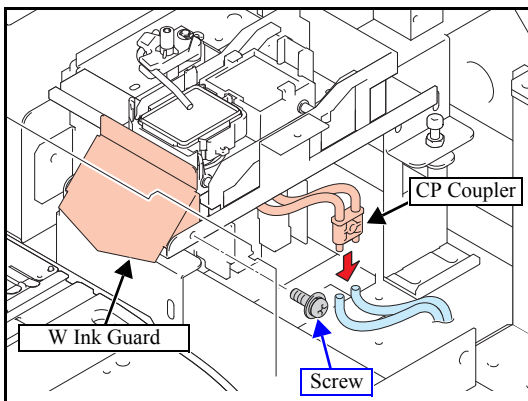

1. Turn off the main power supply of the printer.
2. Manually move the head unit over the platen.
3. Remove the following covers.
 - Station Cover U
 - Wiring Cover
4. Remove the **W ink guard**.
5. Remove two tubes from the **CP coupler**.

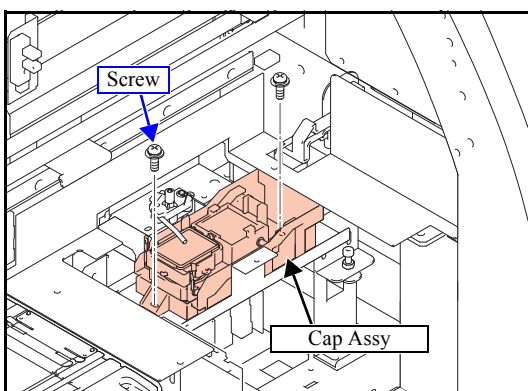

6. Remove the screws, and then remove the **cap assy** while turning back the PC pipe.
7. Reverse the disassembly procedure for reassembly.



At the time of assembly, screw up the cap assy while striking it against a recess.

6.2.7 Cap Head Assy

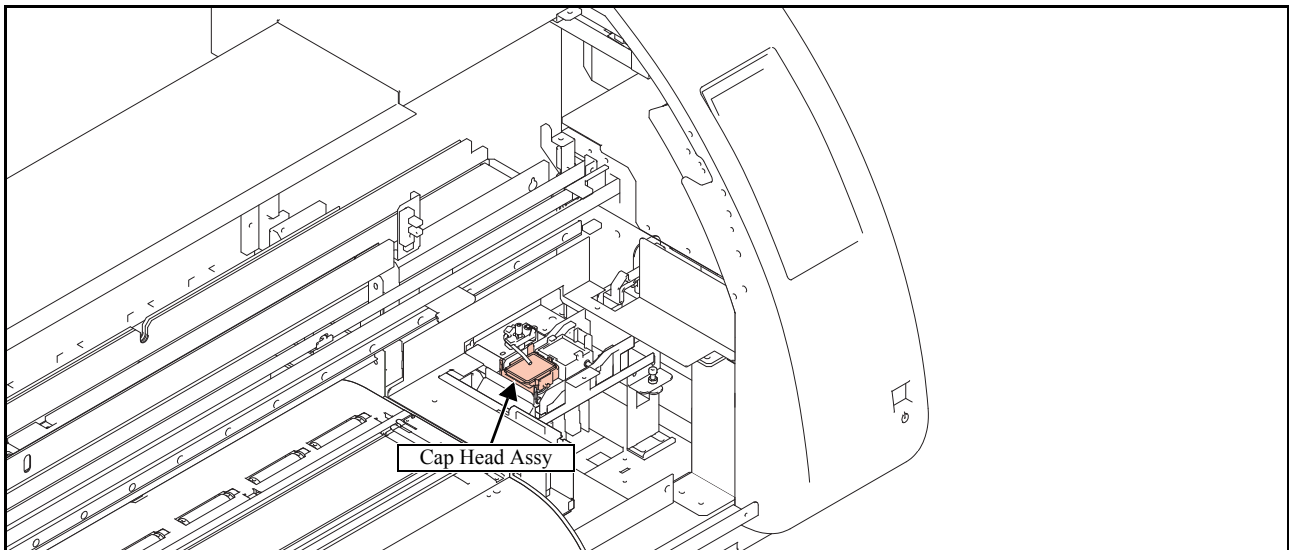

Work procedures



Be sure to turn off the main circuit breaker to prevent unexpected movements of the printer.

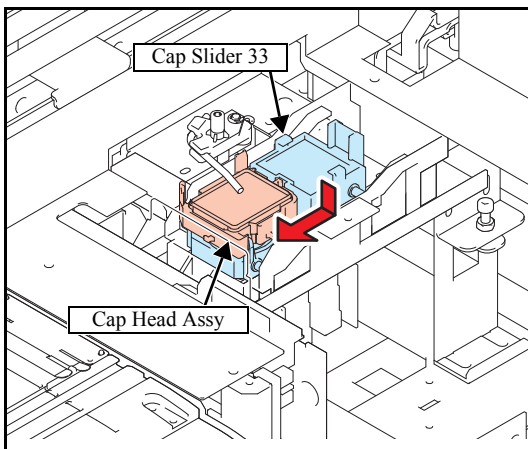

1. Turn off the main power supply of the printer.
2. Manually move the head unit over the platen.
3. Remove the following covers.
 - **Station Cover U**
 - **Wiring Cover**
4. While pushing down the **cap head assy**, slide it to the left and remove it from cap slider 33.

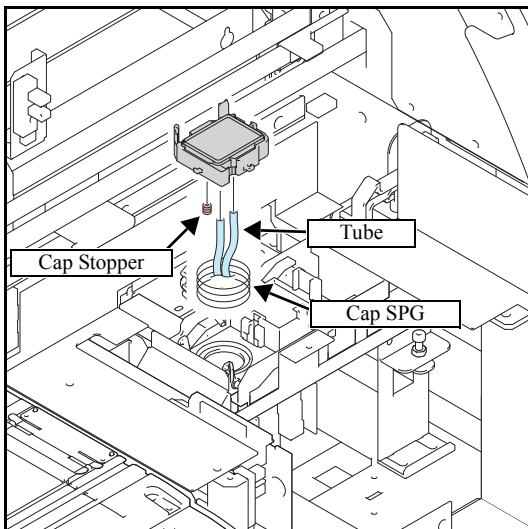

5. Remove the tube, **cap SPG** and **cap stopper** from the cap head assy.

6. Reverse the disassembly procedure for reassembly.

1

2

3

4

5

6

7

8

6.2.8 Valve Assy

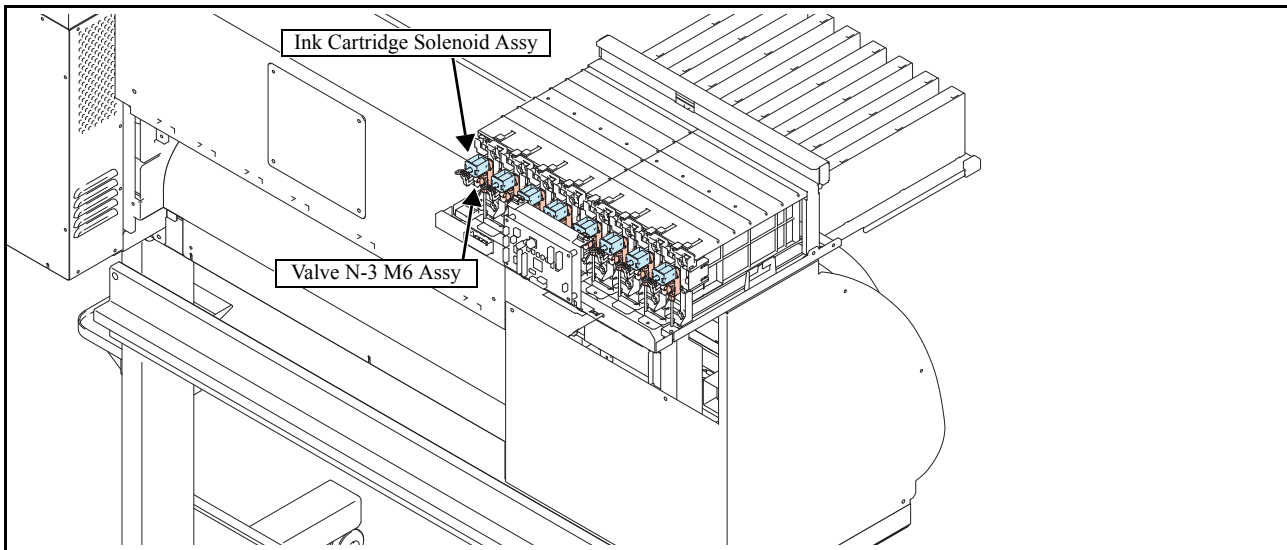

Work procedures



Use protection glasses and gloves during works.
Depending on the working condition, ink may reach your eyes or your skin may be roughed due to ink.

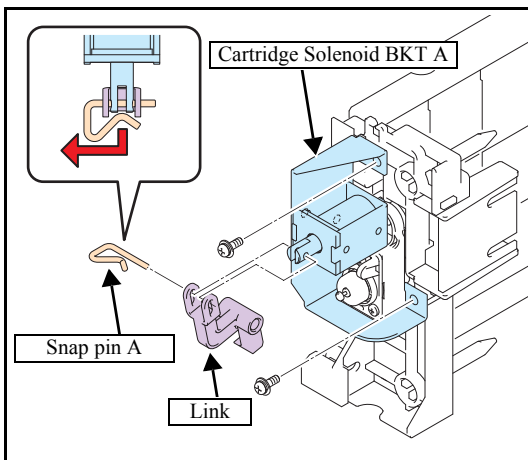

1. Execute [MACHINE SETUP] — [#ADJUST] — [HEAD ADJUST] — [HEAD WASH] to discharge the ink. (See 4.2.7)

2. Remove the following covers.

- ICU Cover F
- ICU Cover R

3. Remove **snap pin A** and then the **link**.

4. Remove screws to take off the **cartridge solenoid BKT A** together with the solenoid.

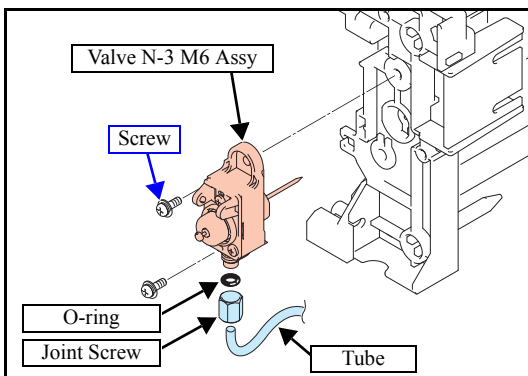

5. Remove the **valve N-3 M6 assy** and loosen the **joint screws** to remove the tube.



Take care not to contaminate the surroundings with ink.
Also, take care not to lose the O-ring.

6. Reverse the disassembly procedure for reassembly.

6.2.9 Changing Joint

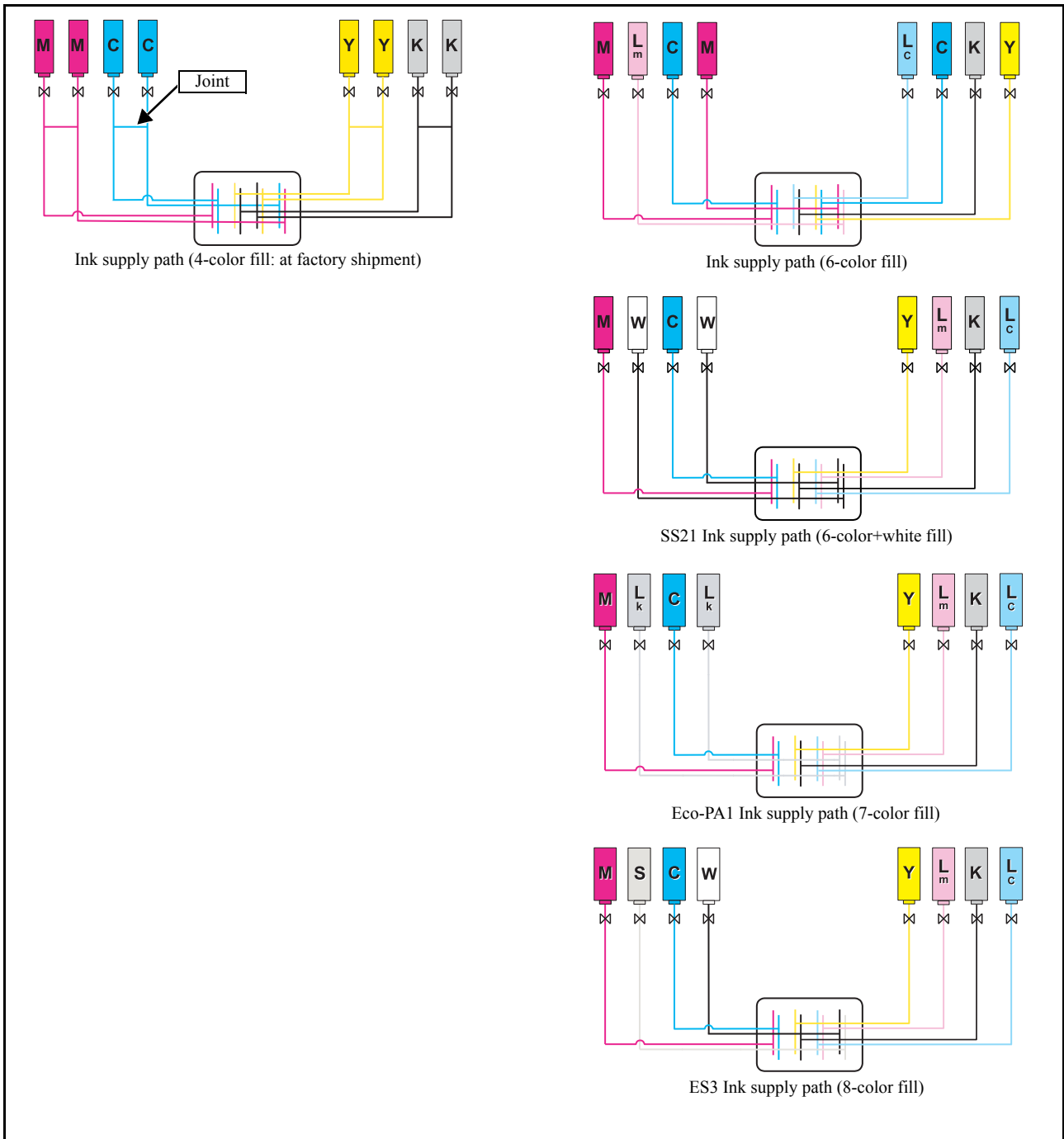

1

2

3

4

5

6

7

8

■ Outline

The above three ways of setting up the ink supply channel are possible in this machine.

Four colors are set at factory shipment, but it is possible to change to other colors by coupler opening and closing. Following is a description of procedures to change to six or more colors.

6.2.9 Changing Joint

1.0

■ Work procedures



Use protection glasses and gloves during works.
Depending on the working condition, ink may reach your eyes or your skin may be roughed due to ink.

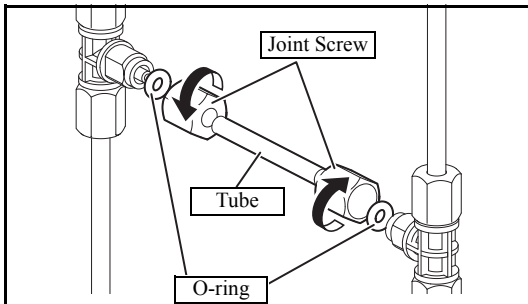

1. Execute [MACHINE SETUP] — [#ADJUST] — [HEAD ADJUST] — [HEAD WASH] to discharge the ink. (See 4.2.7)
2. Remove the **cartridge cover**.
3. Loosen the **joint screws** and remove the **tube** and **O-rings**.

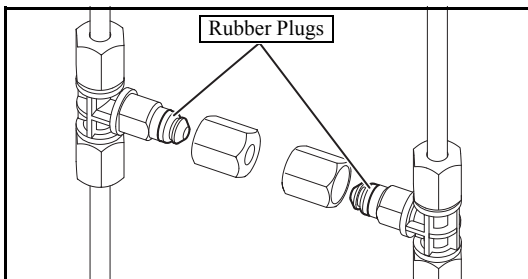

4. Put on the **rubber plugs** on the coupler.



Make sure that O-ring is not remaining in the joint screws.

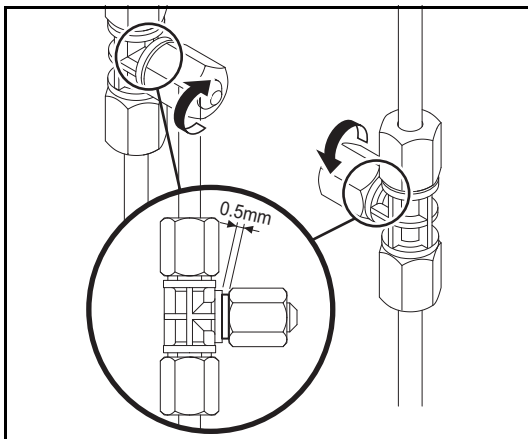

5. Tighten the joint screws.
Leave a space of around 0.5 mm between the coupler and screw.



When clamping the joint screws, do not clamp them too much.

1

2

3

4

5

6

7

8

1

2

3

4

5

Disassembly and Reassembly

6

6.1 Covers	6.2 Ink-related Parts	6.3 Cut Head Carriage
6.4 Drive System	6.5 Electrical Parts	6.6 Sensors

7

8

6.3.1 Pen Assy and LED Pointer

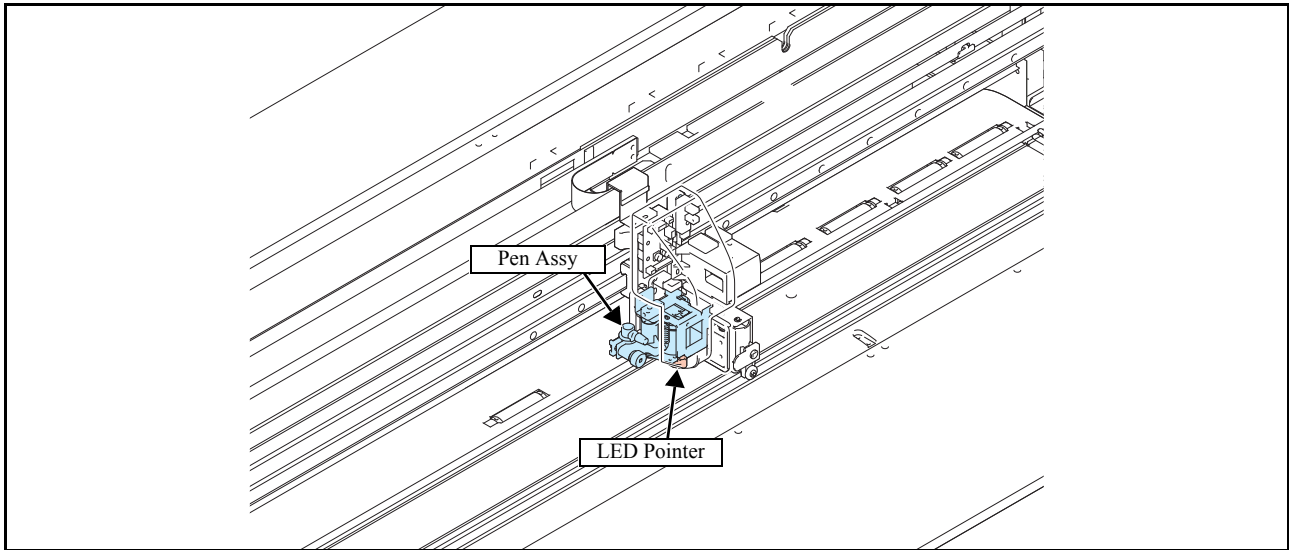

1

2

3

4

5

6

7

8

Work procedures

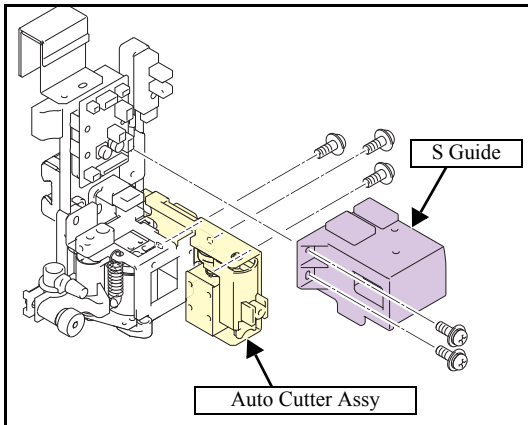

1. Remove the following covers.

- C Head cover
- CY cover F

2. Move the cutting carriage on the platen.

3. Remove the **S-guide**, and then the **auto cutter assy**.



Take care not to change the orientation of the hook of the whirl-stop SP.

Changing the orientation will change the pen pressure and the pen landing values.

4. Remove screws from the rear and the front of the printer to take off the **pen assy**.

5. Remove the connector from PCB and also **LED pointer** from the pen assy.

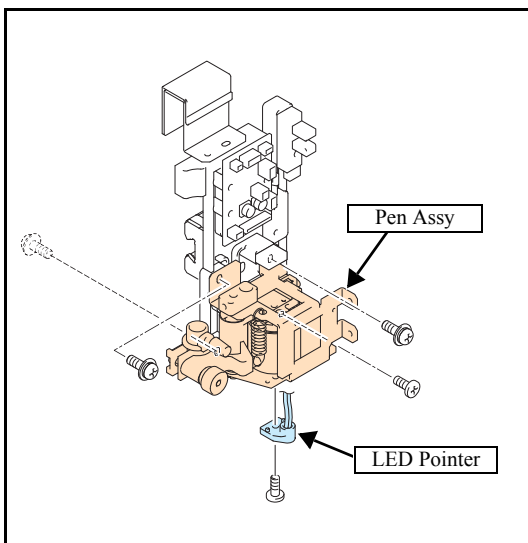

6. Reverse the disassembly procedure for reassembly.

6.3.2 Auto Cutter Assy

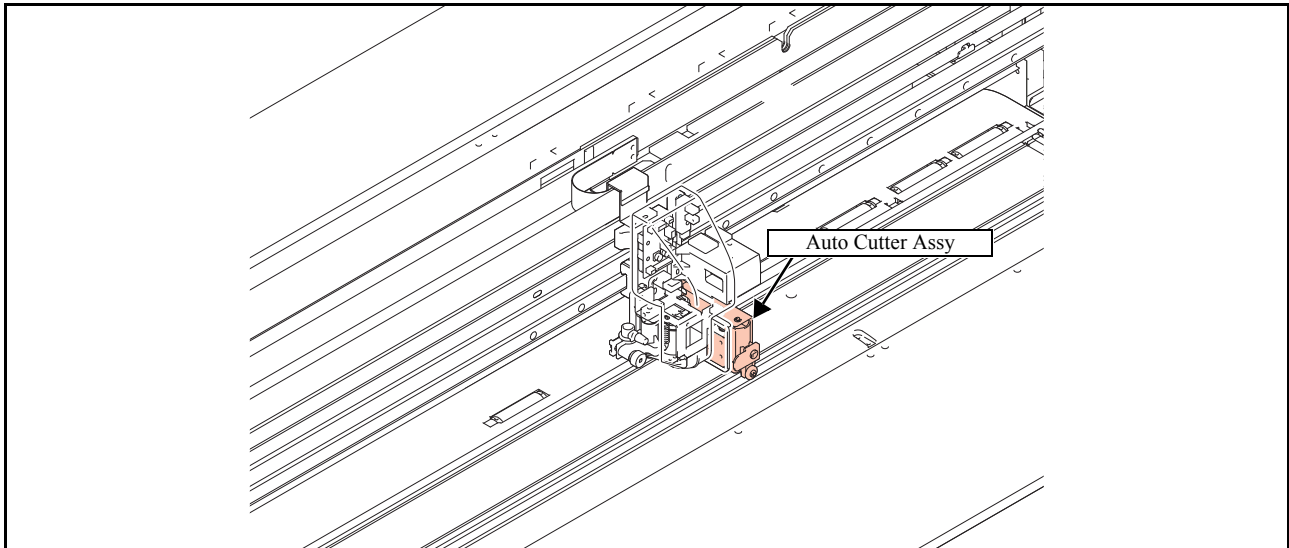

1

2

3

4

5

6

7

8

■ Work procedures



Be sure to turn off the main circuit breaker to prevent unexpected movements of the printer.

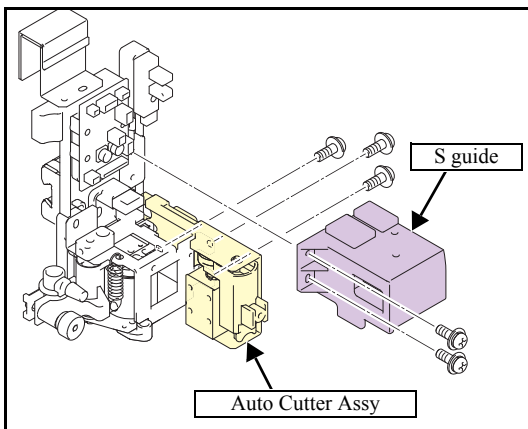

1. Remove the following covers.

- CY Cover F
- Head Cover

2. Move the cutting carriage on the platen.

3. Remove the **S-guide** and then the **auto cutter assy**.



Take care not to change the orientation of the hook of the whirl-stop SP.
Changing the orientation will change the pen pressure and the pen landing values.

4. Reverse the disassembly procedure for reassembly.

6.3.3 Mark Assy

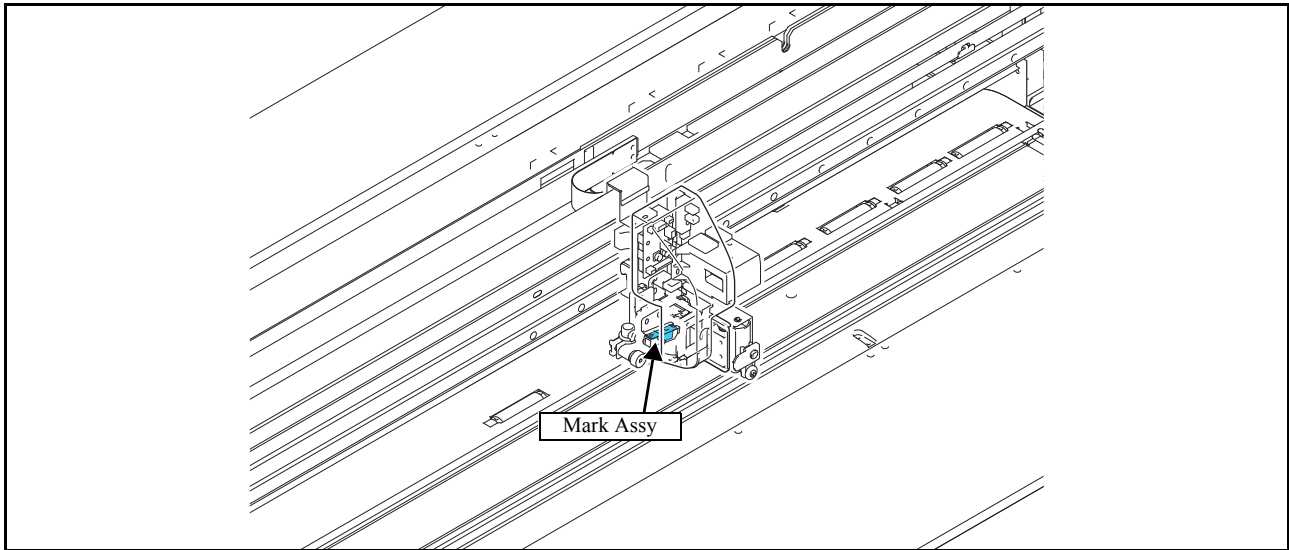

1

2

3

4

5

6

7

8

Work procedures



Be sure to turn off the main circuit breaker to prevent unexpected movements of the printer.

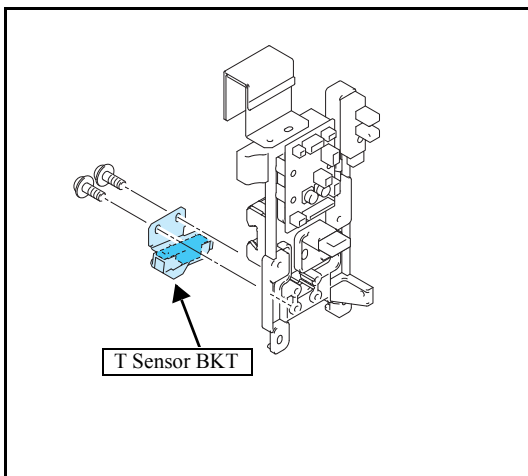

1. Remove the pen Assy.
 - Refer to “6.3.1 Pen Assy and LED Pointer”.
2. Remove the connector (CN3) of the mark sensor Assy from the cutter slider PCB Assy.
3. Remove the mark sensor Assy together with the **T sensor BKT** from the rear of the printer.

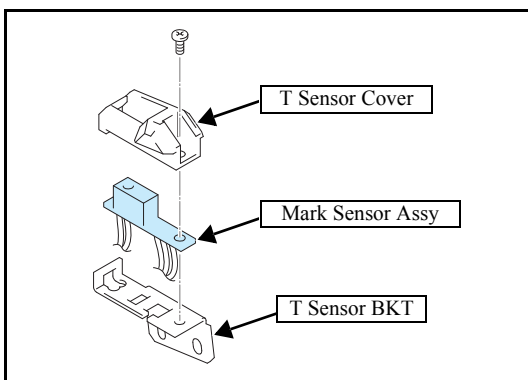

4. Remove the **T sensor cover** and then **mark sensor Assy**.

5. Reverse the disassembly procedure for reassembly.



In reassembly, pay attention to harness treatment.

1

2

3

4

5

Disassembly and Reassembly

6

**6.1
Covers**

**6.2
Ink-related Parts**

**6.3
Cut Head Carriage**

**6.4
Drive System**

**6.5
Electrical Parts**

**6.6
Sensors**

7

8

6.4.1 X-axis Motor

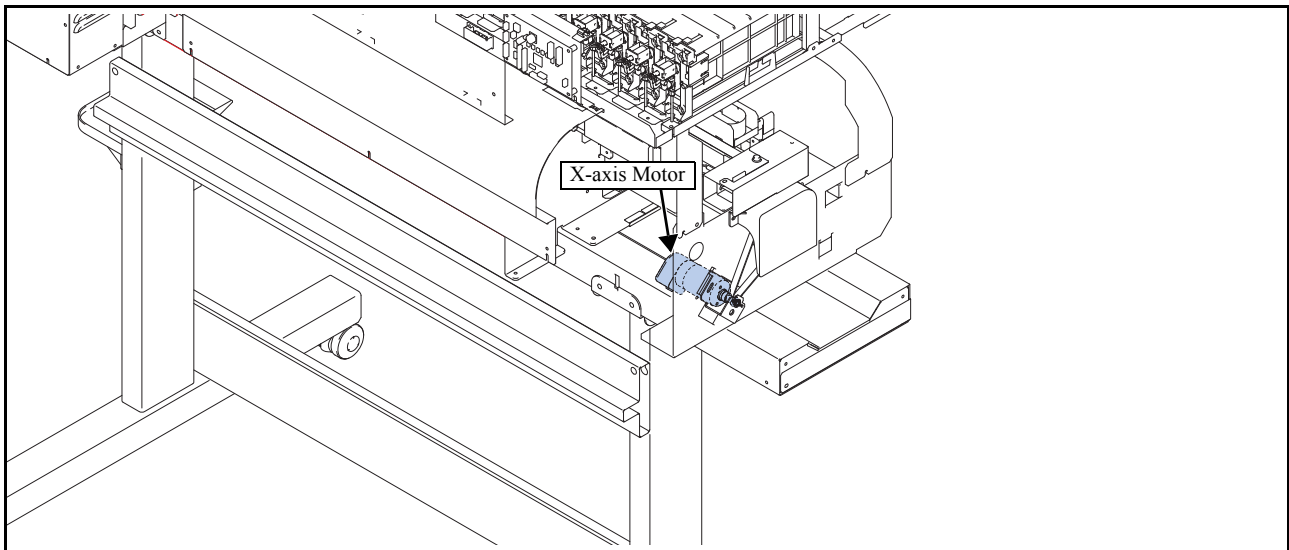

1

2

3

■ Work procedures



Be sure to turn off the main circuit breaker to prevent unexpected movements of the printer.

4

5

6

7

8

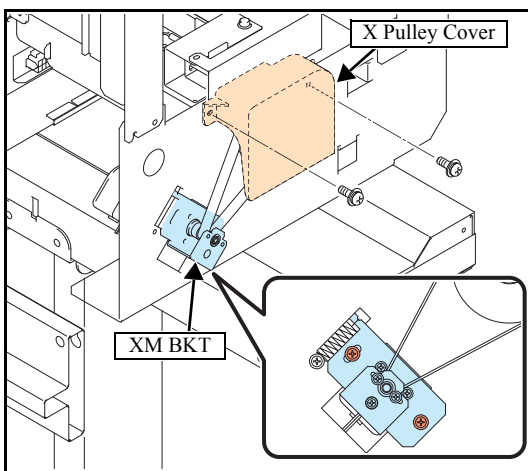

1. Remove the following covers.

- Maintenance Cover L
- Cartridge cover
- Left cover

2. Remove the X pulley cover.

3. Remove the screws that fix the XM BKT.

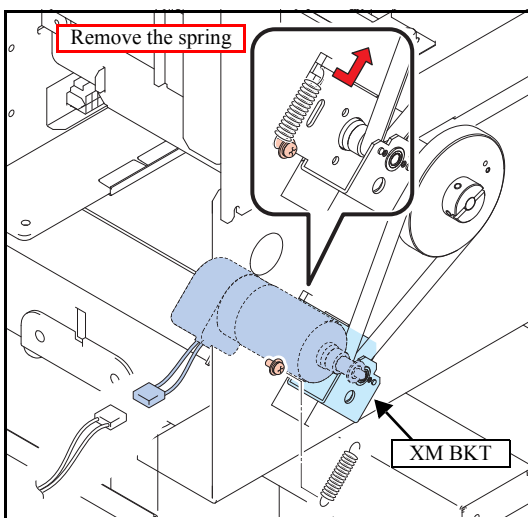

4. Disconnect the X-axis motor connector.

5. Remove the spring, and then remove the XM BKT and X-axis motor from the main body.

6.4.1 X-axis Motor

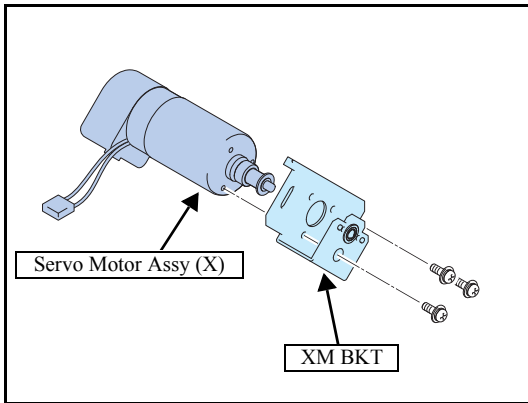

6. Remove the **XM BKT** screws and then the **servo motor assy (X)**.

7. Reverse the disassembly procedure for reassembly.



After mounting the motor, if the hunting sound is heard when the motor drives, make adjustments making reference to the following:

- Adjusting the X-axis motor current



The belt tension does not need to be adjusted.

1

2

3

4

5

6

7

8

6.4.2 Y-axis Motor

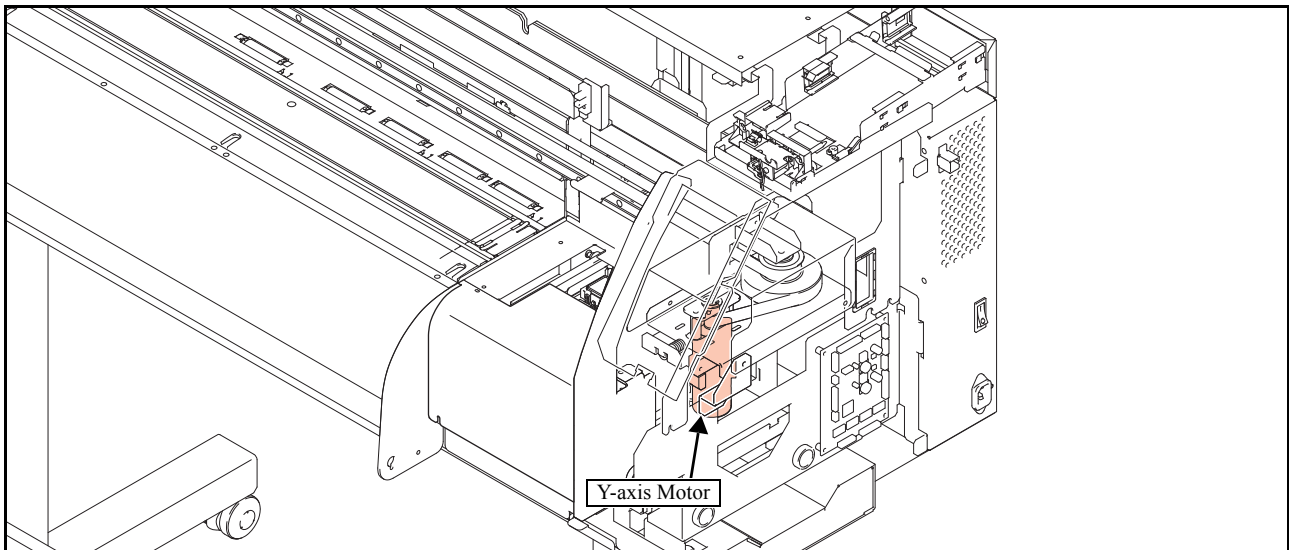

■ Work procedures



Be sure to turn off the main circuit breaker to prevent unexpected movements of the printer.

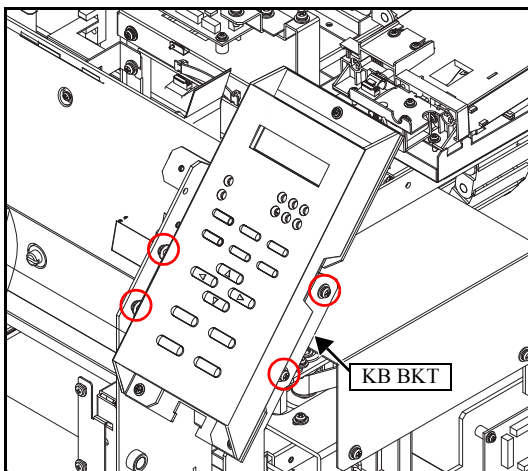

1. Remove the following covers.

- C Y Cover F
- KB Cover
- Right Cover

2. Remove the **KB BKT** screws, disconnect the connector and then remove the **keyboard assy**.

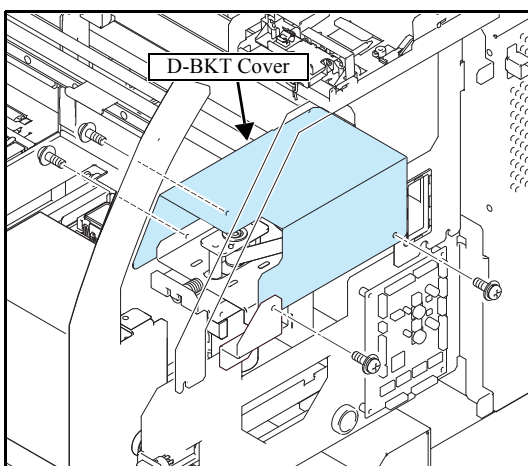

3. Manually move the print head carriage on the platen and remove the **D-BKT cover**.

1

2

3

4

5

6

7

8

6.4.2 Y-axis Motor

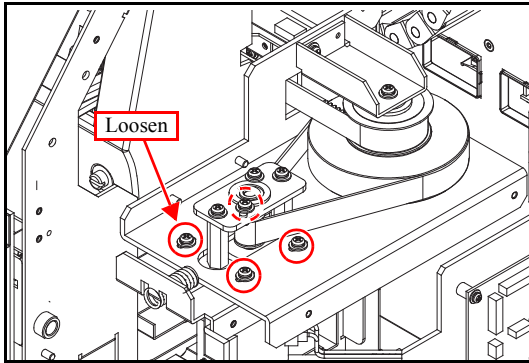

4. Loosen the screws that affix the Y-axis motor belt tension to reduce the belt tension.

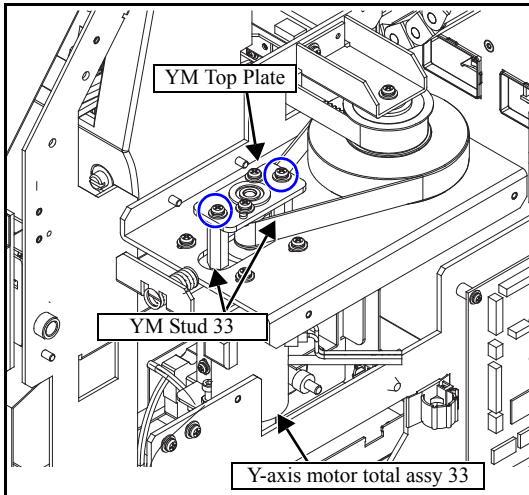

5. Remove the screws from the top of the Y-axis motor and then remove the **YM top plate**.

6. Remove the **YM stud 33**.

7. Remove the **Y-axis motor total assy 33** while taking care not to drop it.

8. Release the clamps and the cable (directly connected to main PCB assy).

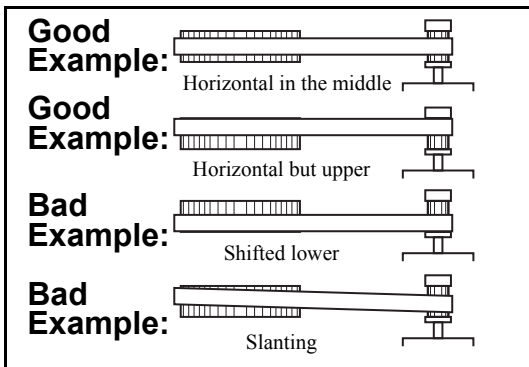

9. Reverse the disassembly procedure for reassembly.



- Mount the Y-axis motor so that the belt is horizontal and centered on the Y drive pulley (upper side is also acceptable).
- After mounting the motor, if the hunting sound is heard when the motor drives, make adjustments making reference to the following:
 - Adjusting the Y-axis motor current

1

2

3

4

5

6

7

8

6.4.3 Y Drive Pulley

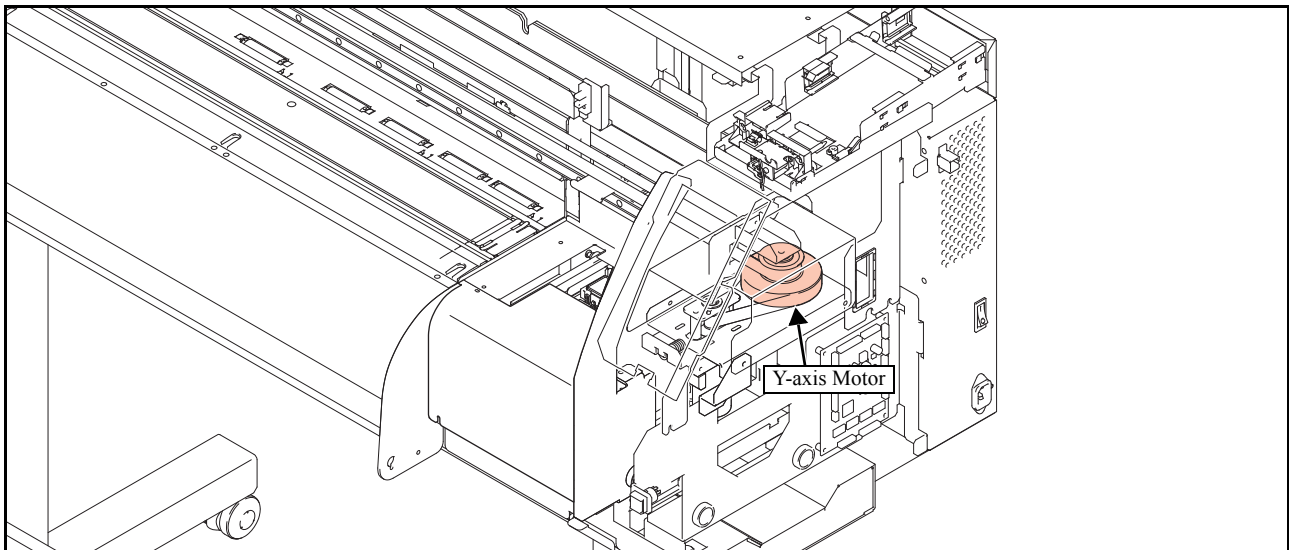

1

2

3

Work procedures



Be sure to turn off the main circuit breaker to prevent unexpected movements of the printer.

4

5

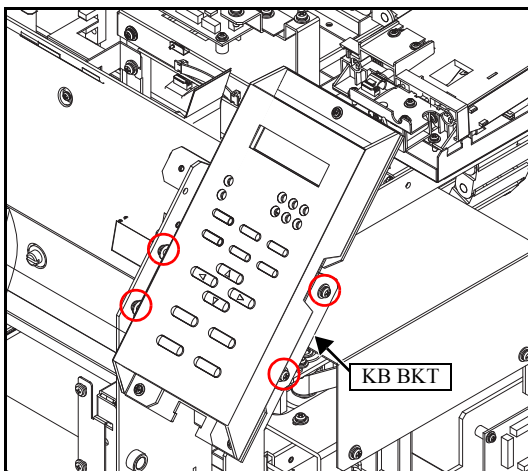

1. Remove the following covers.

- C Y Cover F
- KB Cover
- CY-T Cover
- Right Cover
- Maintenance Cover L
- Cartridge Cover
- Left Cover

2. Remove the **KB BKT** screws, disconnect the connector and then remove the **keyboard assy.**

6

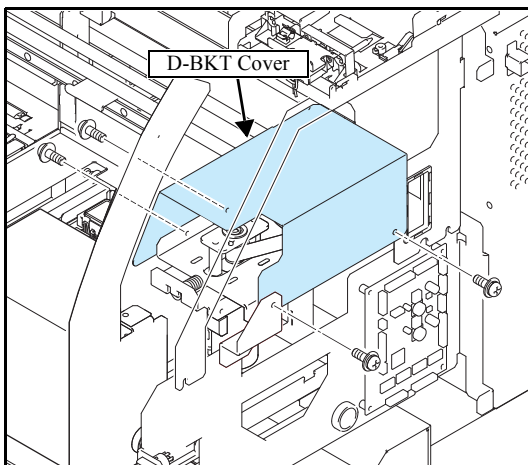

3. Manually move the print head carriage on the platen and remove the D-BKT cover.

7

8

6.4.3 Y Drive Pulley

1.0

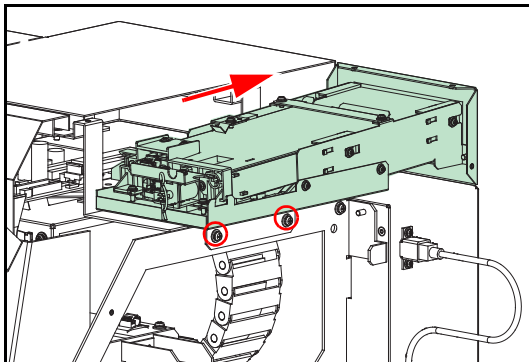

4. Remove the screws that hold the washing cartridge assy in place, and slide the **washing cartridge assy** towards the back.

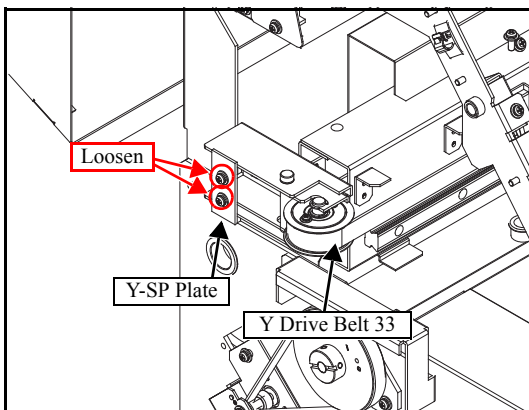

5. Loosen the screws from the Y-SP plate on the left side of the main body, and release the tension of the Y drive belt.

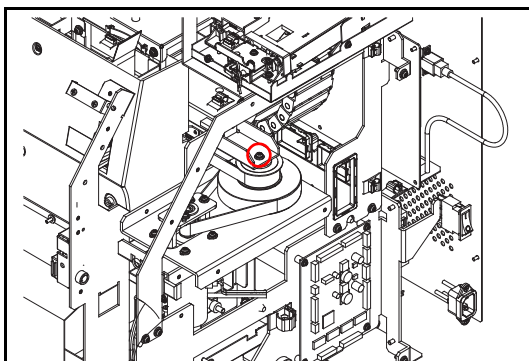

6. Remove the screw from the top of the Y drive pulley.

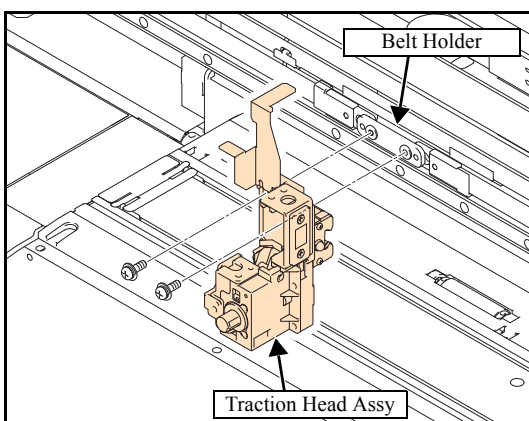

7. Remove the traction head assy screws and separate them from the belt holder.

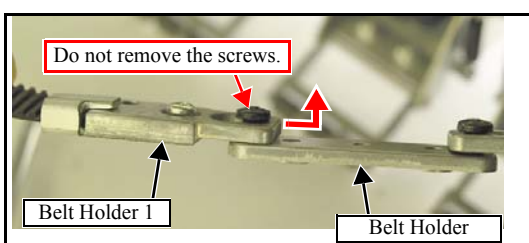

8. Slide out the connection point of the Y drive belt, and remove either the left or right **belt holder 1** from the **belt holder**.



Do not remove the Y drive belt from the slider.

1

2

3

4

5

6

7

8

6.4.3 Y Drive Pulley

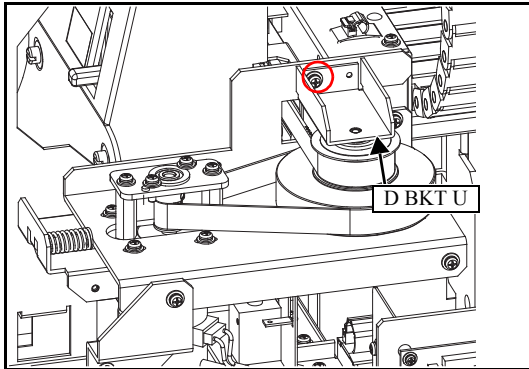

9. Remove the screw, and detach the **D BKT U** from the Y drive pulley.

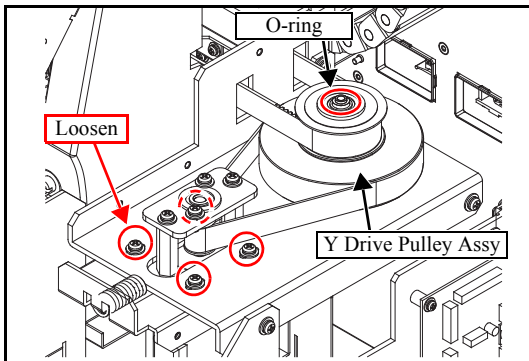

10. Loosen the screws for fixing the Y-axis motor belt tension, and reduce the tension of the belt.

11. Remove the O-ring from the top of the Y drive pulley, and then remove the two belts to detach the Y drive pulley.



Take care not to lose the O-ring.

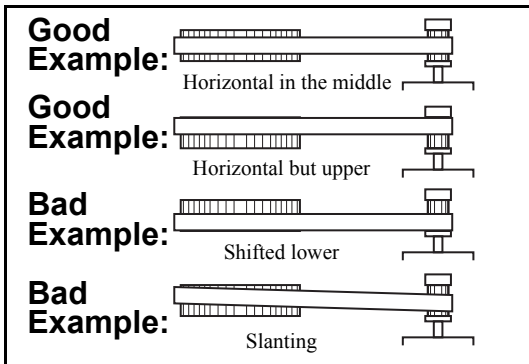

12. Reverse the disassembly procedure for reassembly.



- Mount the Y-axis motor so that the belt is horizontal and centered on the Y drive pulley (upper side is also acceptable).
- After mounting the motor, if the hunting sound is heard when the motor drives, make adjustments making reference to the following:
 - Adjusting the Y-axis motor current

1

2

3

4

5

6

7

8

6.4.4 Y Drive Belt

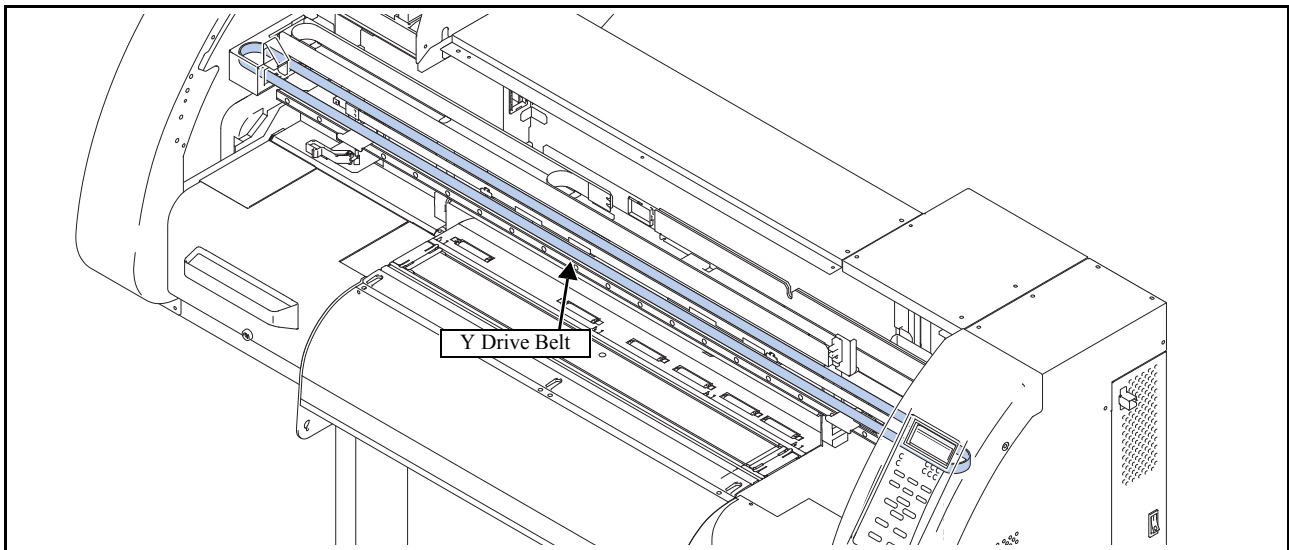

1

2

3

Work procedures



Be sure to turn off the main circuit breaker to prevent unexpected movements of the printer.

4

5

6

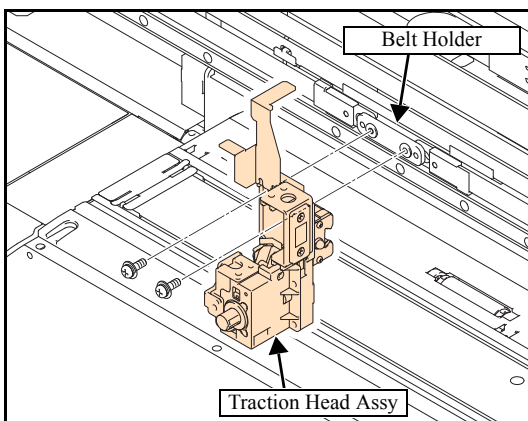

1. Remove the following covers.

- C Y Cover F
- CY-T Cover
- Maintenance Cover L
- Cartridge Cover
- Left Cover

2. Remove the traction head assy screws and separate them from the belt holder.

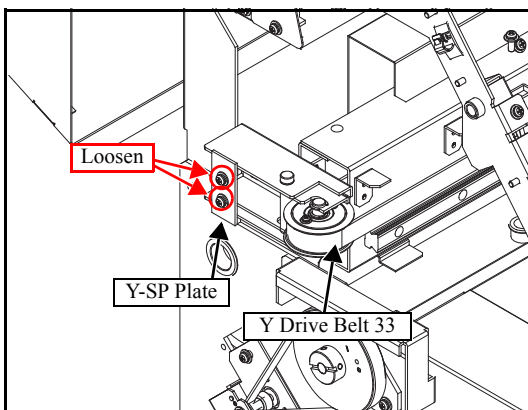

3. Loosen the screws from the Y-SP plate on the left side of the main body, and release the tension of the Y drive belt.

7

8

6.4.4 Y Drive Belt

1.0

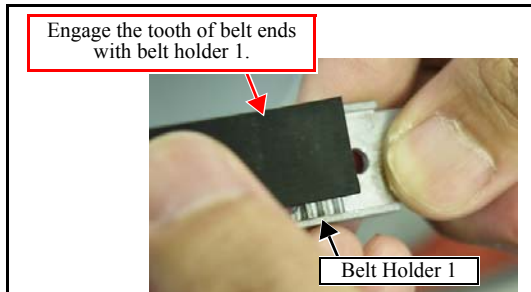
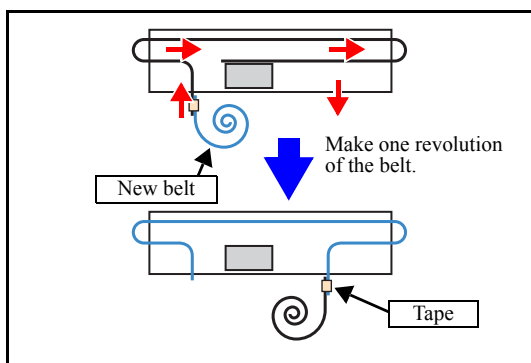
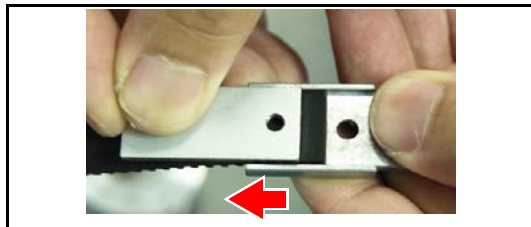
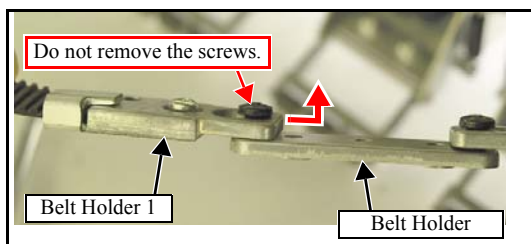

4. Slide out the connection point of the Y drive belt, and remove either the left or right **belt holder 1** from the **belt holder**.

5. Remove the belt holder1 screws.

6. Pry open the **belt holder S** with a slotted screwdriver or the like, then slide the belt holder S to detach from the belt.

7. Stick together the ends of the old belt and the new belt using rubber tape or the like, and make one revolution of the belt.

8. Once the belt has made one revolution, remove the joining tape and pass the belt through the rear side of the slider.

9. Align the belt holder 1 and the teeth on the left and right belt ends, and attach the belt holder S while engaging the teeth. Then tighten the screw.

10. Connect the left and right belt holders 1 with the belt holder.

11. Attach the belt holder and slider using a screw.

12. Loosen the screws on the Y-SP plate on the left side of the main body, and increase the Y drive belt tension.

13. Reverse the disassembly procedure for the subsequent reassemblies

1

2

3

4

5

6

7

8

6.4.5 Linear Encoder Scale

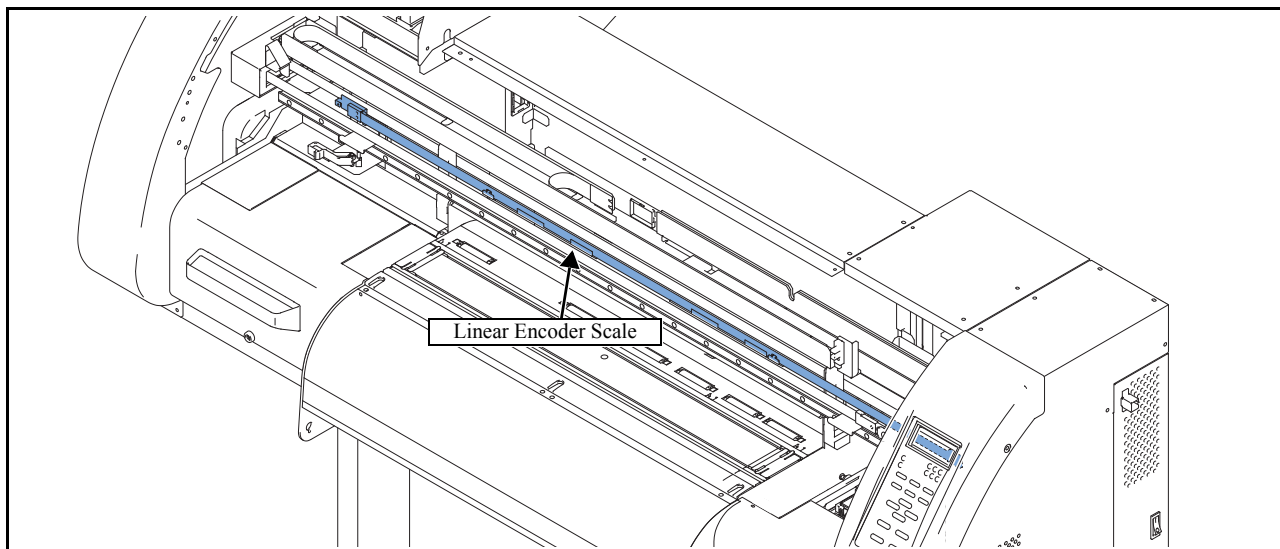

1

2

3

4

5

6

7

8

Work procedures



Be sure to turn off the main circuit breaker to prevent unexpected movements of the printer. While at work, be sure not to attach fingerprints or oil to the linear encoder scale. Also, pay attention not to break or scratch it. (If contaminated, clean the scale with a neutral detergent.)

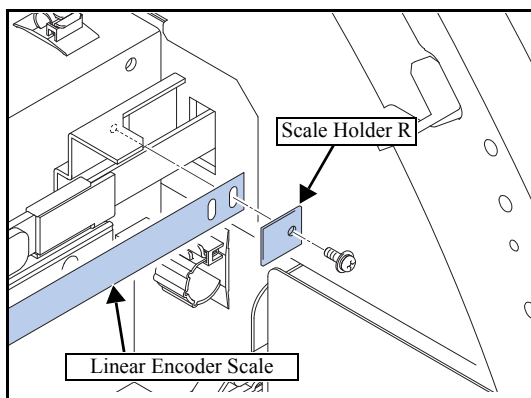

1. Remove the following covers.

- CY Cover F
- Head Cover

2. Remove the **Encoder PCB Assy**.

- [6.5.12 Encoder PCB Assy](#)

3. Remove the screws from the right end of the linear encoder scale, and detach the **linear encoder scale**.

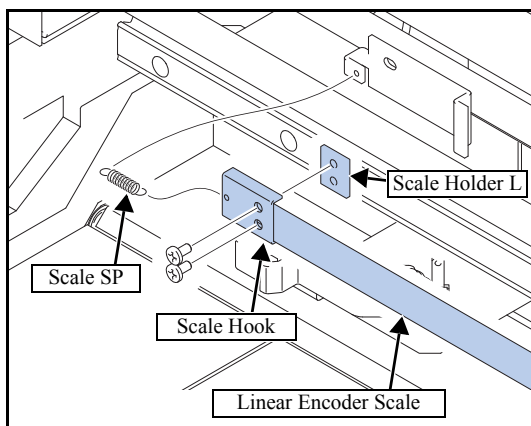

4. Remove the screw from the left end of the linear encoder scale, and detach the **linear encoder scale** together with the springs.

5. Remove the **scale hook** and **scale holder R** from the linear encoder scale.

6.4.5 Linear Encoder Scale

1.0



6. Peel off the left end (the side with two holes) of the protection film on the new linear encoder scale.



While at work, be sure not to attach fingerprints or oil to the linear encoder scale. Also, pay attention not to break or scratch it. (If contaminated, clean the scale with a neutral detergent.)

7. Mount the scale hook on the linear encoder scale so that the surface where the protection film is stuck faces to the Y bar side.



8. Engage the **scale hook** with the **scale base L** through a spring, and mount the **linear encoder scale** on the scale base R while peeling off the protection film.

9. Reverse the disassembly procedure for the subsequent reassemblies

1

2

3

4

5

6

7

8

6.4.6 Wiper Unit

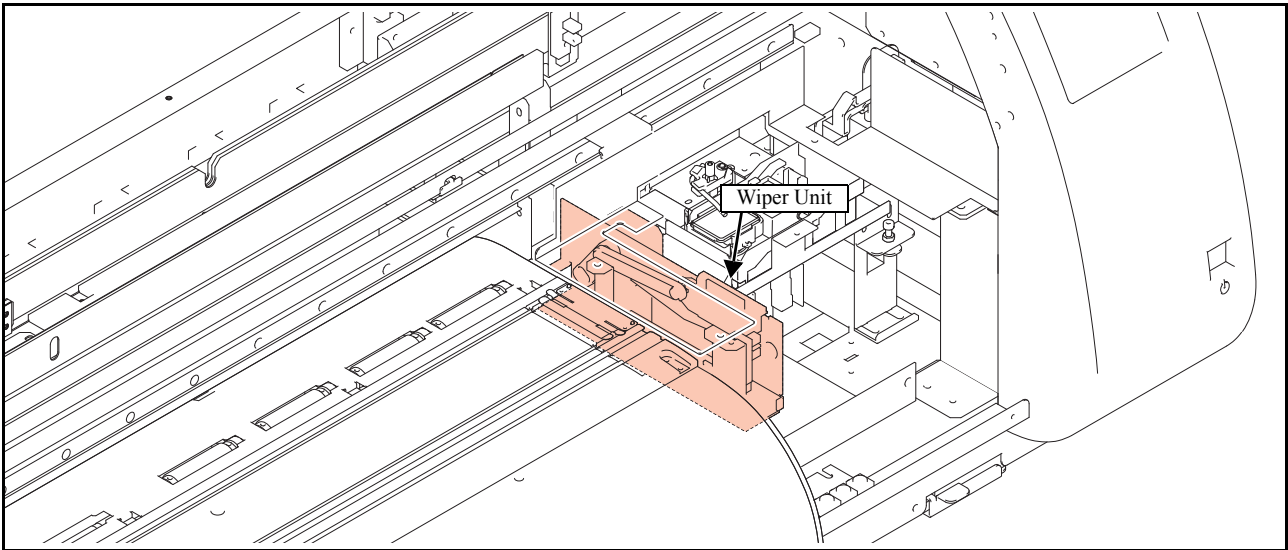

Work procedures



Be sure to turn off the main circuit breaker to prevent unexpected movements of the printer.

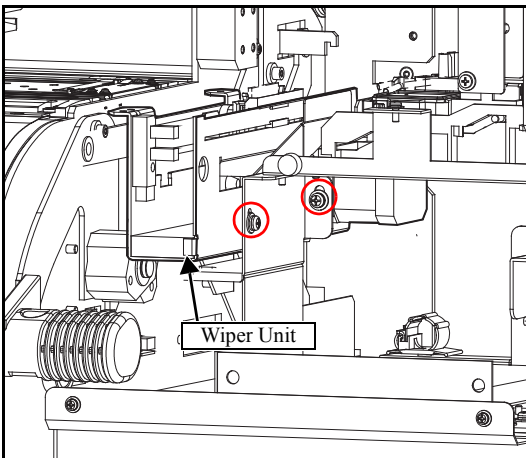

1. Remove the following covers.

- Station Cover U
- C Station Cover 2

2. Remove the screws, and remove the wiper assy from the base.

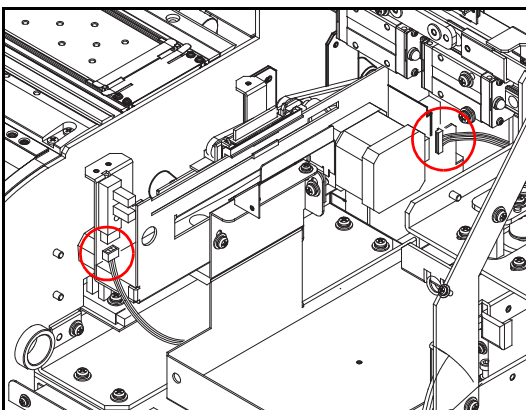

3. Release the clamp under the station and disconnect the wiper motor connector.

4. Disconnect the wiper origin sensor connector.

1

2

3

4

5

6

7

8

6.4.6 Wiper Unit

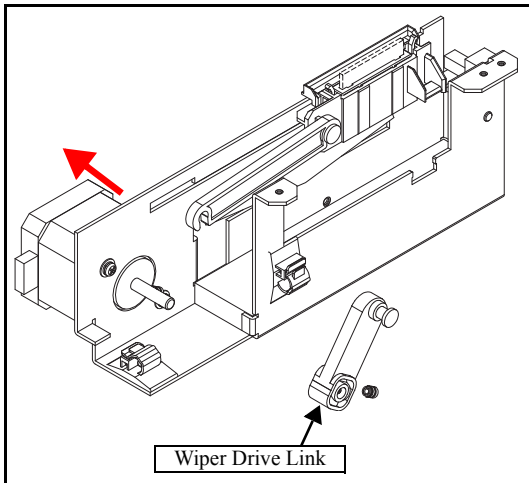

5. When replacing only the motor, remove the wiper drive link and the screws to detach the motor.

6. Reverse the disassembly procedure for reassembly.

1

2

3

4

5

6

7

8

6.4.7 GR Roller Assy

1.1

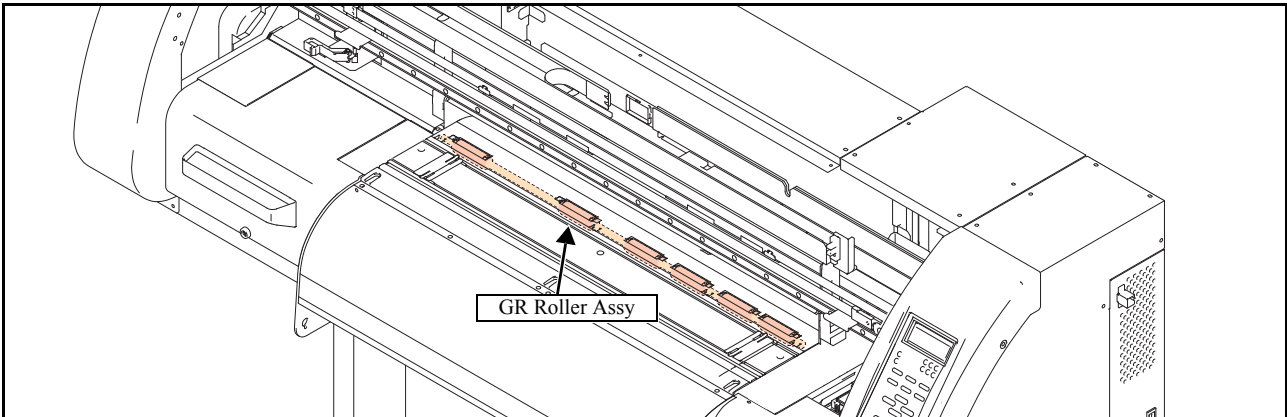

■ Work procedures



After turning off the sub and main power switches, unplug the power cord. Make sure to take 15 minutes before restarting the operation.

It is very dangerous if sleep mode functions mistakenly during the operation.

Moreover, the PCB may be damaged in case electric charge still remains inside.

Also, there is a possibility of electric shock because of high power voltage applied to the high-pressure part of the power supply PCB assy. Take care to avoid contact with it.

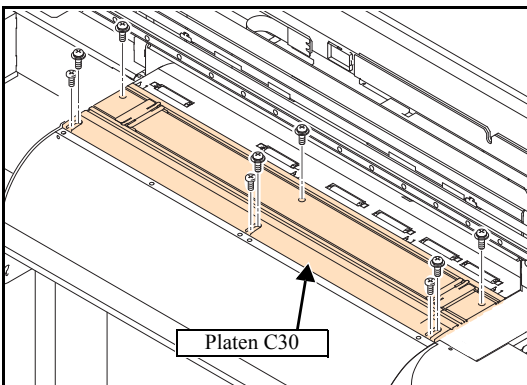

1. Remove the following covers.

- CY Cover F
- Cartridge Cover
- Maintenance Cover L
- Left Cover
- Left Station Cover
- Heater connector Cover
- MS Cover 2
- MS Cover 1

2. Remove the connector of pre-heater and print heater and then remove the **platen cover R** and **platen C30**.

3. Loosen all PF coupling set screws.

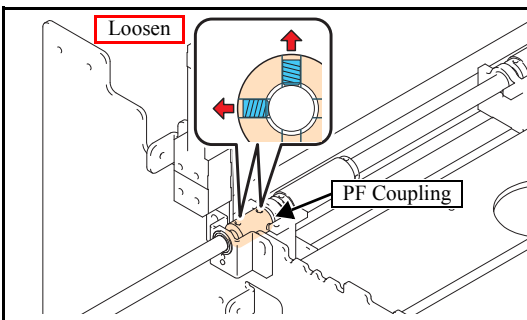

4. Remove all GR roller 30 set screws from the lower part of the spike shaft.

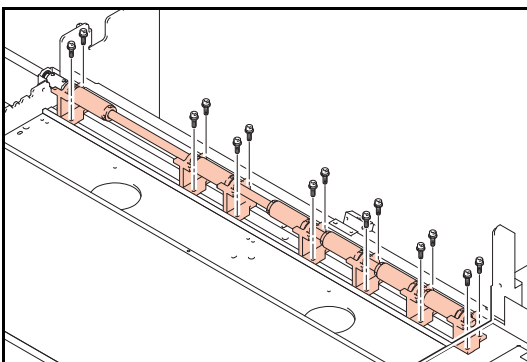

1

2

3

4

5

6

7

8

6.4.7 GR Roller Assy

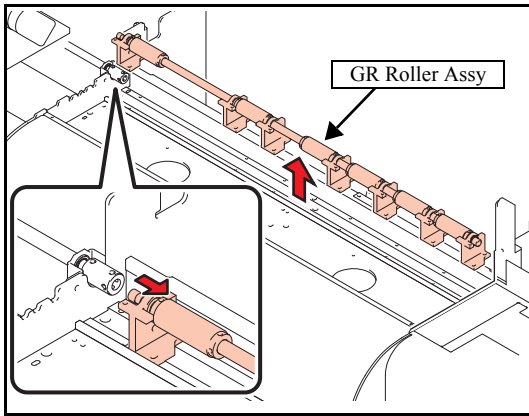

5. Disconnect the left end of the shaft from the PF coupling and remove the **GR roller assy**.

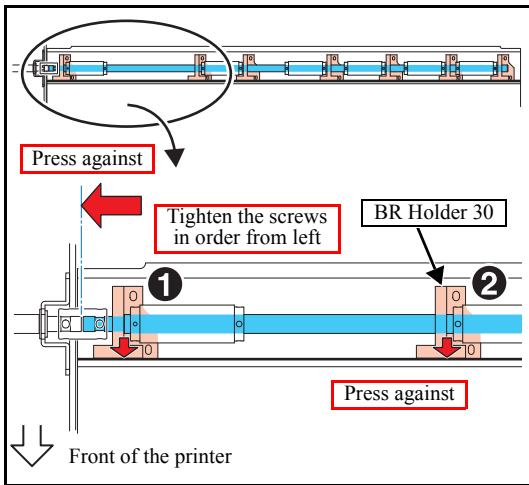

6. Reverse the disassembly procedure for reassembly.



For installation, tighten the screws in order, starting with the leftmost one while pushing the shaft to the left and pushing the BR holder 30 toward the front.

1

2

3

4

5

6

7

8

6.4.8 Take-up Motor

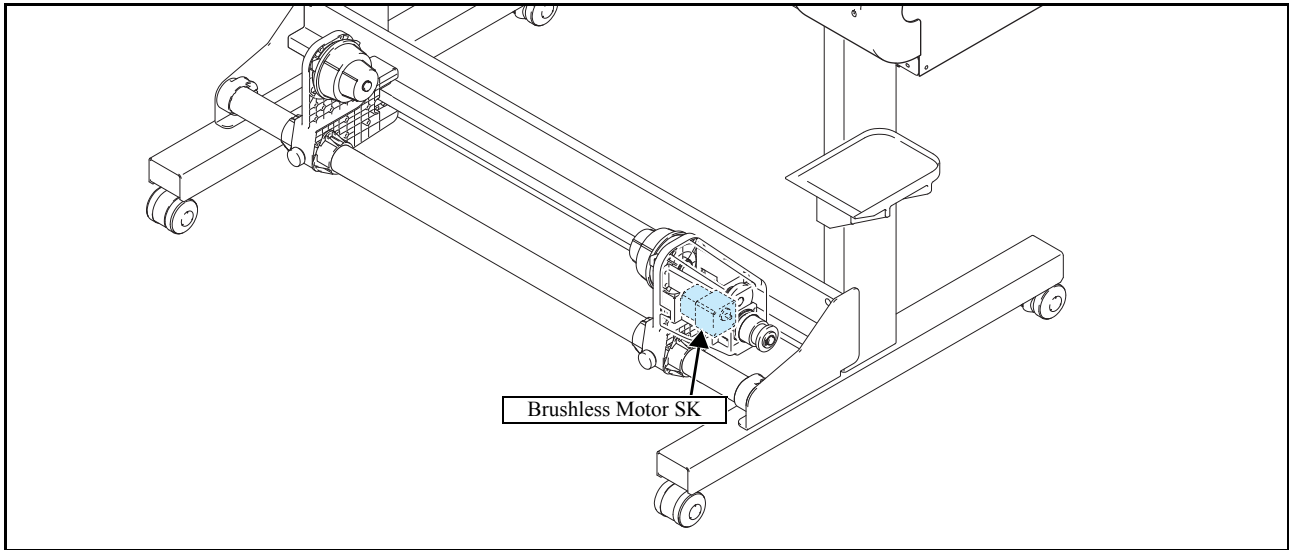

Work procedures

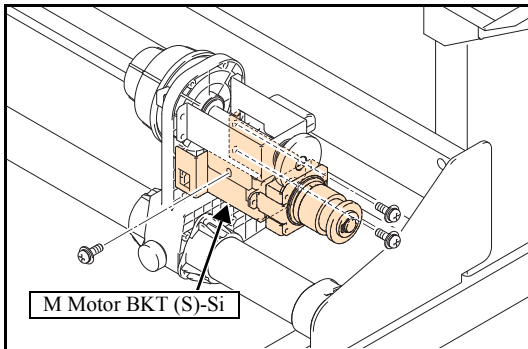

1. Remove the **take-up cover (S)**.
2. Disconnect all connectors on the take-up motor PCB assy.
3. Remove the **M motor BKT (S)-Si** from the **Roll base 2(BR)**.

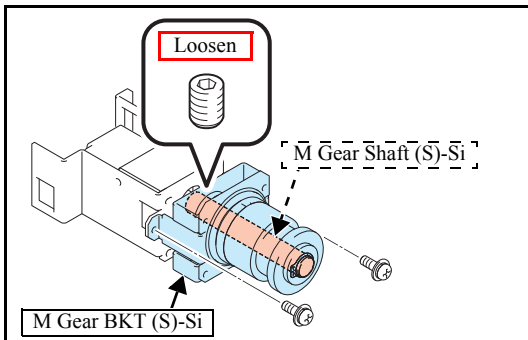

4. Loosen the fixing screws that connect the motor shaft and M gear shaft (S)-Si and then remove the **M gear BKT (S)-Si**.

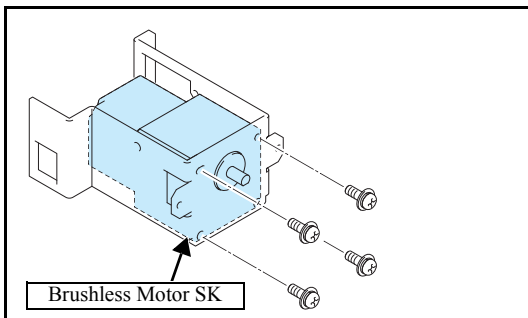

5. Remove the **brushless motor SK**.

6. Reverse the disassembly procedure for reassembly.

IMPORTANT When fixing the motor shaft and M gear shaft (S)-Si with fixing screws, be sure to tighten the screws at the plane port of the motor shaft D cut point.

<Good example> <Bad example>

1

2

3

4

5

6

7

8

6.4.9 C Connecting Hook

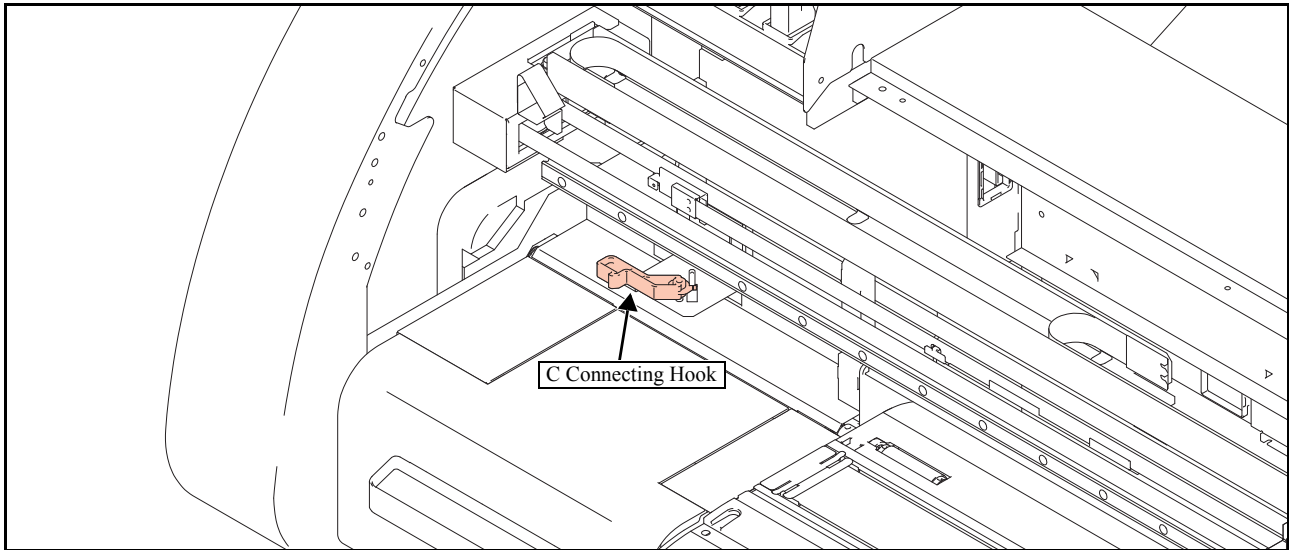

1

2

3

4

5

6

7

8

Work procedures



Be sure to turn off the main circuit breaker to prevent unexpected movements of the printer.

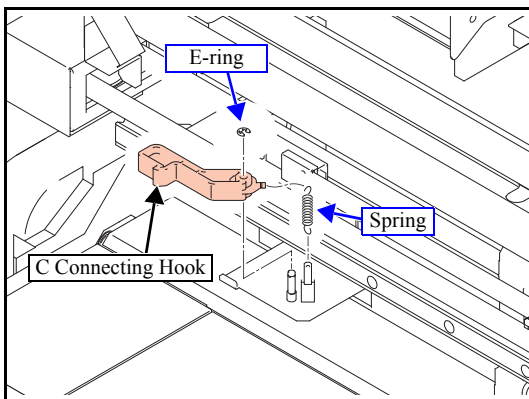

1. Move the cut head carriage on the platen.

2. Remove the spring and E-ring to take off the C connecting hook.



Take care not to lose the spring and E-ring.

5

6

7

8

6.4.10 P Head Connecting Hook

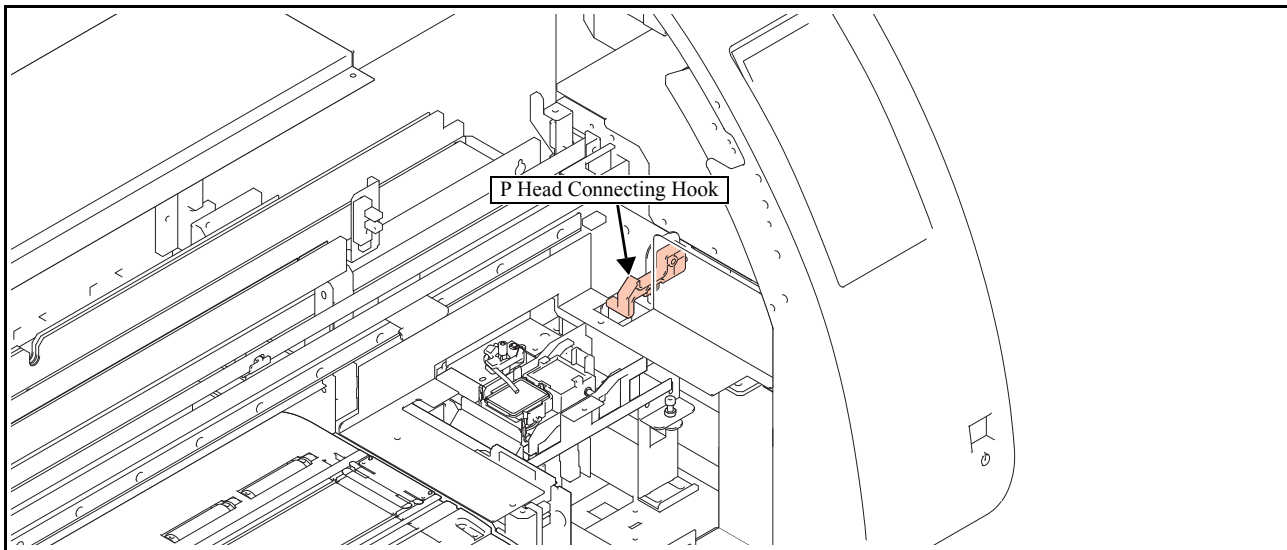

1

2

3

Work procedures



Be sure to turn off the main circuit breaker to prevent unexpected movements of the printer.

4

5

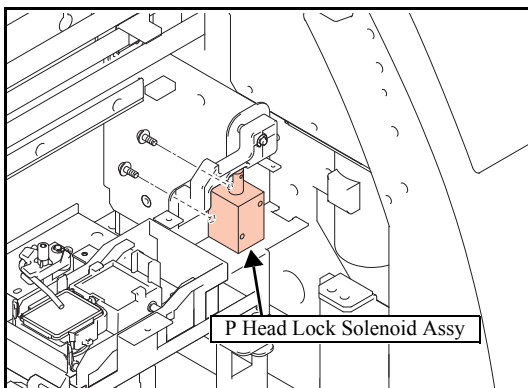

1. Remove the following covers.

- CY Cover F
- Station Cover U
- C Station Cover 2
- KB Cover

2. Remove **P head lock solenoid assy** from the CP station base.

6

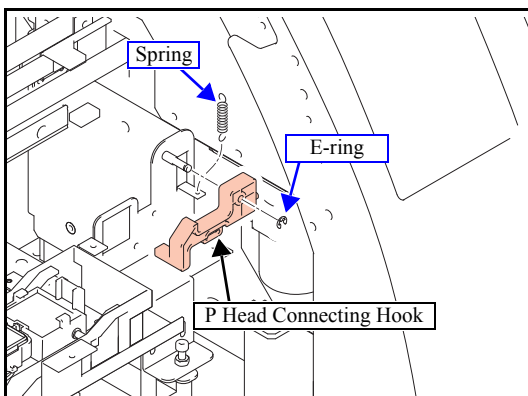

3. Remove the spring and E-ring to take off the **P head connecting hook**.



Take care not to lose the spring and E-ring.

7

8

6.4.11 Clamp Assy

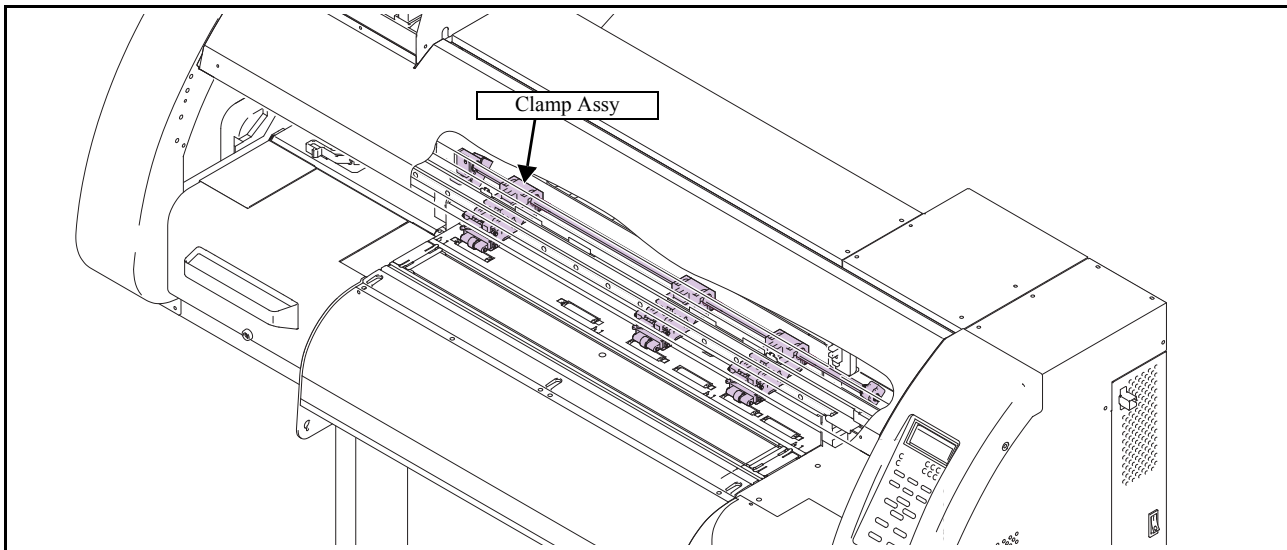

1

2

3

4

5

6

7

8

Work procedures



Be sure to turn off the main circuit breaker to prevent unexpected movements of the printer.

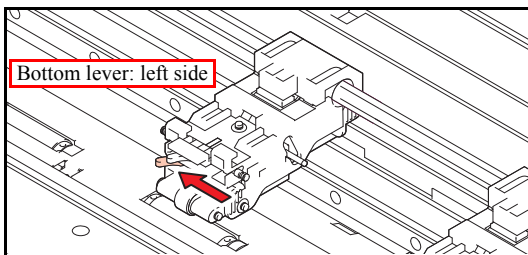

1. Remove the **CY cover F**.

2. Lower the clamp lever and set the lever below the clamp Assy to the left.

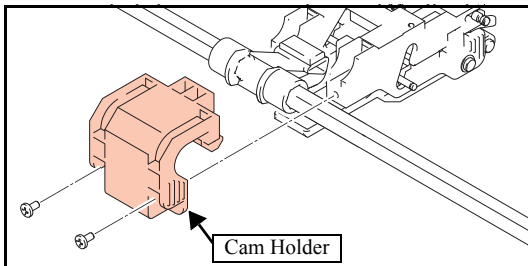

3. Remove the cam holder from the rear of the printer and clamp Assy.

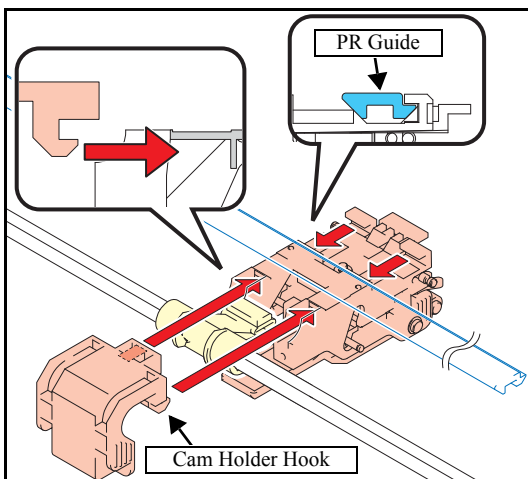

4. Reverse the disassembly procedure for reassembly.



- When mounting the clamp Assy, place the front right and left hooks on the PR guide and mount it horizontally so that the right and left cam holder hooks can be placed in the groove of the clamp Assy.
- For easy work, set clamp pressure to Low by manual operation and lower the clamp lever.

1

2

3

4

5

Disassembly and Reassembly

6

6.1 Covers	6.2 Ink-related Parts	6.3 Cut Head Carriage
6.4 Drive System	6.5 Electrical Parts	6.6 Sensors

7

8

6.5.1 Power Supply PCB Assy

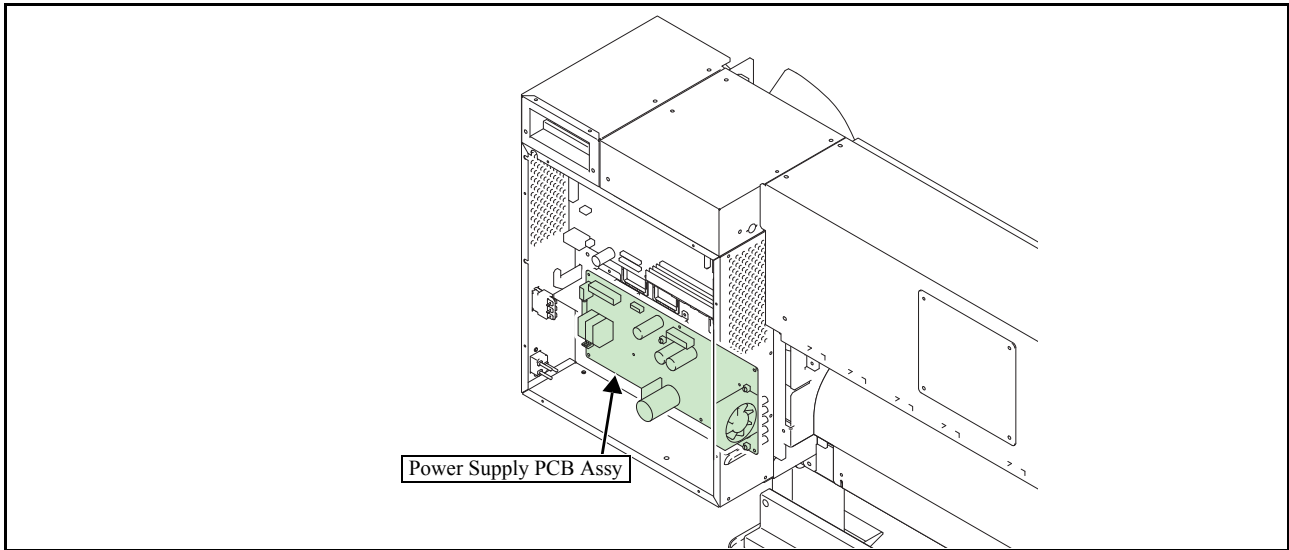

1

2

3

4

5

6

7

8

Work procedures



After turning off the sub and main power switches in order, unplug the power code. Check if no electric charge is remaining in the PCB. Refer to the "4.5.2 Electric charge checking when replace the Electrical Parts" It is very dangerous if sleep mode functions mistakenly during the operation. Moreover, the PCB may be damaged in case electric charge still remains inside. Also there is a possibility of electric shock because of high power voltage applied the high-pressure part of the power supply PCB assy. Take care to avoid contact with it.

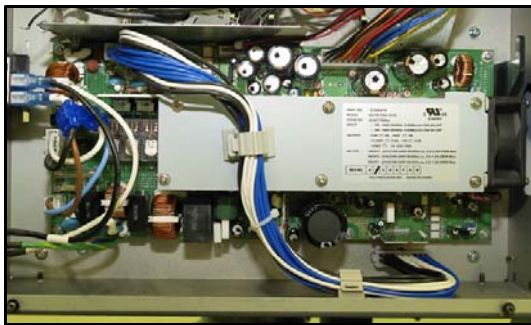

1. Turn off the main power supply and remove the power plug from the main body.
2. Remove the **electrical box cover**.
3. Disconnect all connectors on PCB.

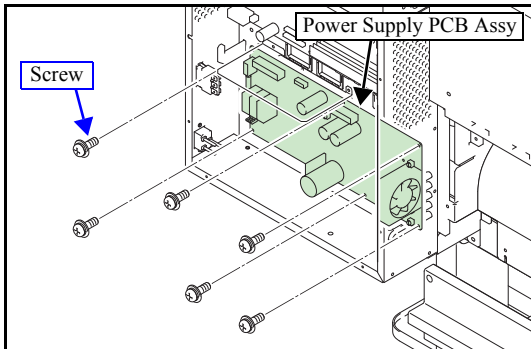

4. Remove the **power supply PCB assy**.
5. Reverse the disassembly procedure for reassembly.



Before mounting the power box cover, adjust the voltage of the power supply PCB assy.

6.5.2 Main PCB Assy

1.2

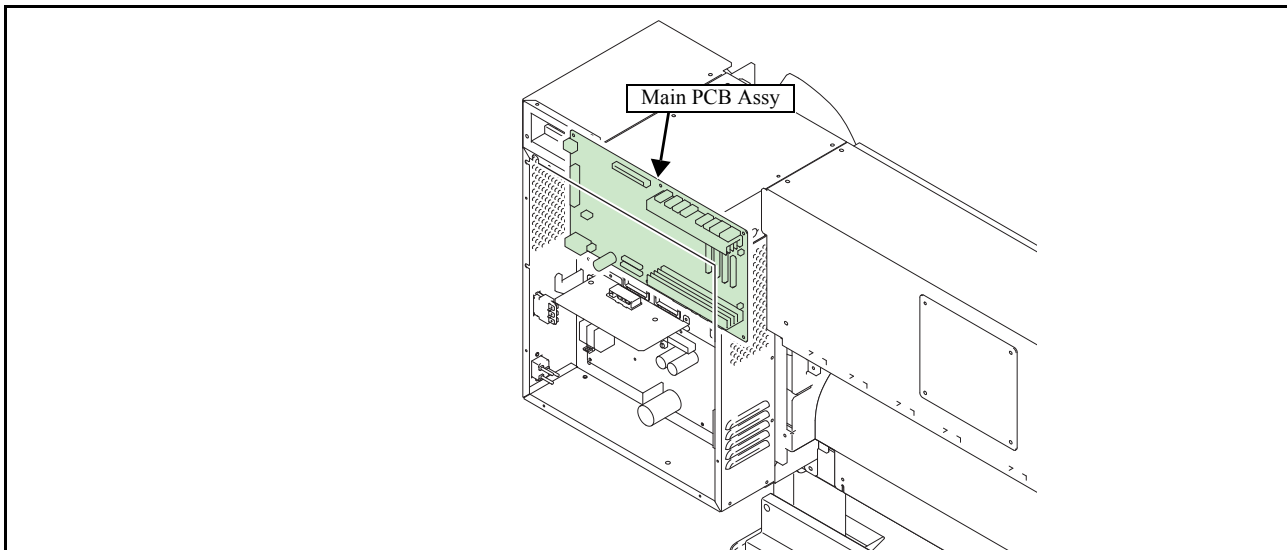

1

2

3

4

5

6

7

8

■ Outline

If main PCB assy has replaced, various parameters must be registered to main PCB assy ROM after the replacement. Considerable time is required to readjust and reconfigure these settings. Therefore, for ease of use and better printing quality, copy (upload) the setting value to a PC before replacement, and write (download) the copied settings onto the main PCB assy from the PC after replacement.



If it is impossible to upload the parameters, note the necessary adjustment values. Then manually register the values after replacing the main PCB assy.

■ Work procedures



After turning off the sub and main power switches in order, unplug the power code.

Check if no electric charge is remaining in the PCB.

Refer to the "4.5.2 Electric charge checking when replace the Electrical Parts"

It is very dangerous if sleep mode functions mistakenly during the operation.

Moreover, the PCB may be damaged in case electric charge still remains inside.

Also there is a possibility of electric shock because of high power voltage applied the high-pressure part of the power supply PCB assy. Take care to avoid contact with it.



1. Turn off the main power supply and remove the power plug from the main body.

2. Remove the **electrical box cover**.

3. Disconnect all connectors on PCB.

6.5.2 Main PCB Assy

1.1

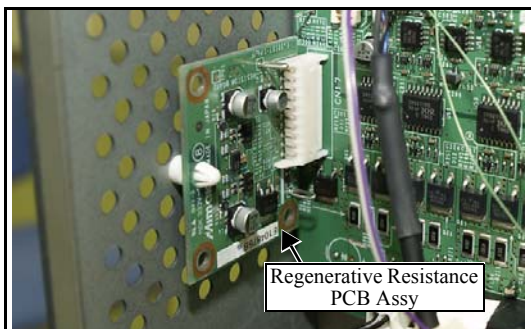

4. Draw the **regenerative resistance PCB assy** out of the main PCB assy.

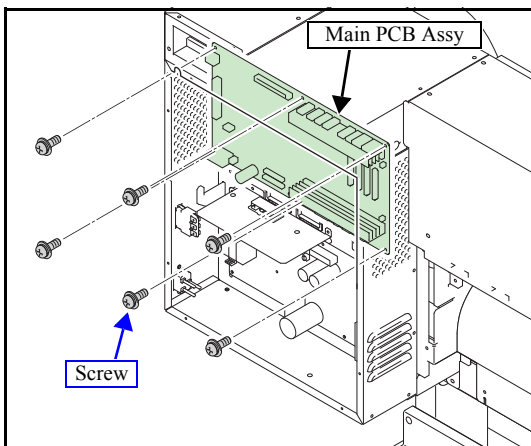

5. Remove the **main PCB assy**.

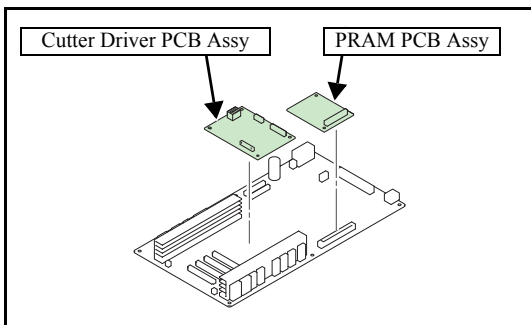

6. Remove the following PCB from the removed main PCB assy.

- **PRAM PCB Assy**
- **Cutter Driver PCB Assy**

7. Reverse the disassembly procedure for reassembly.

1

2

3

4

5

6

7

8

6.5.3 PRAM PCB Assy

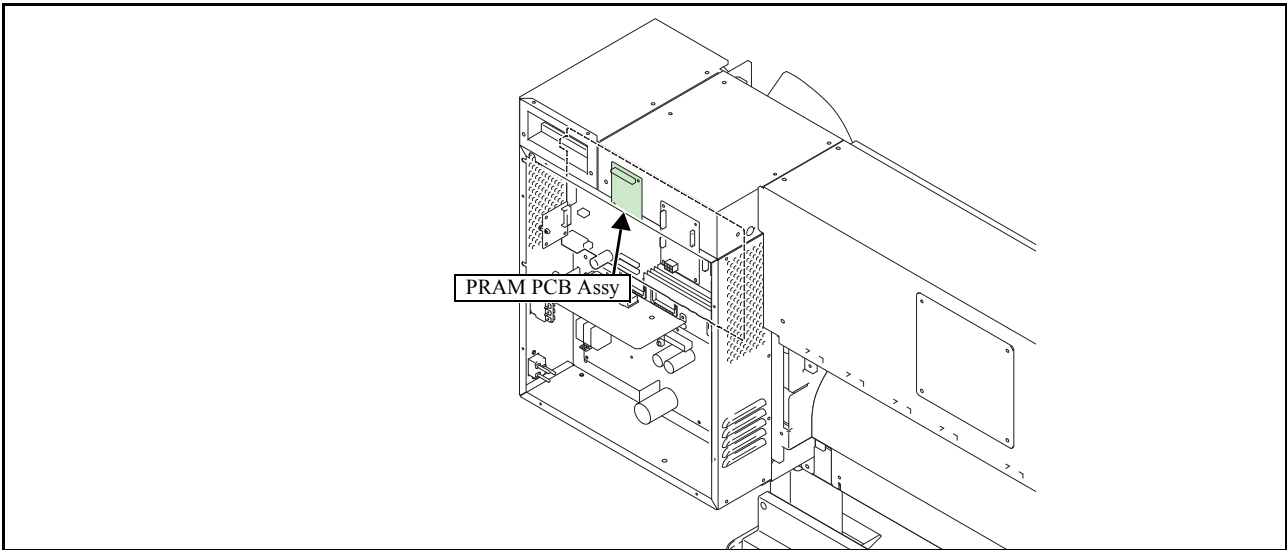

■ Work procedures



After turning off the sub and main power switches in order, unplug the power code.
Check if no electric charge is remaining in the PCB.

Refer to the "4.5.2 Electric charge checking when replace the Electrical Parts"

It is very dangerous if sleep mode functions mistakenly during the operation.

Moreover, the PCB may be damaged in case electric charge still remains inside.

Also there is a possibility of electric shock because of high power voltage applied the high-pressure part of the power supply PCB assy. Take care to avoid contact with it.

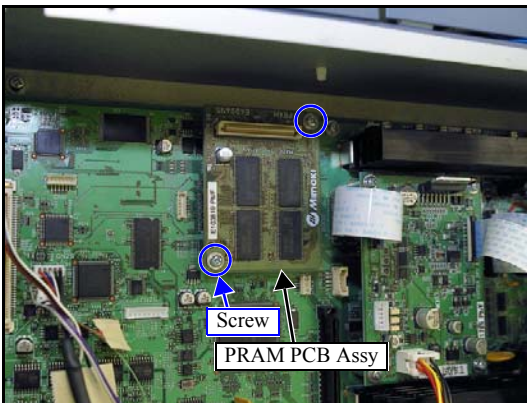

1. Turn off the main power supply and remove the power plug from the main body.
2. Remove the **electrical box cover**.
3. Remove **PRAM PCB assy** from the main PCB assy.



Inter-PCB connector is used to connect PRAM PCB assy to main PCB assy.

4. Reverse the disassembly procedure for reassembly.

1

2

3

4

5

6

7

8

6.5.4 Head Memory PCB Assy

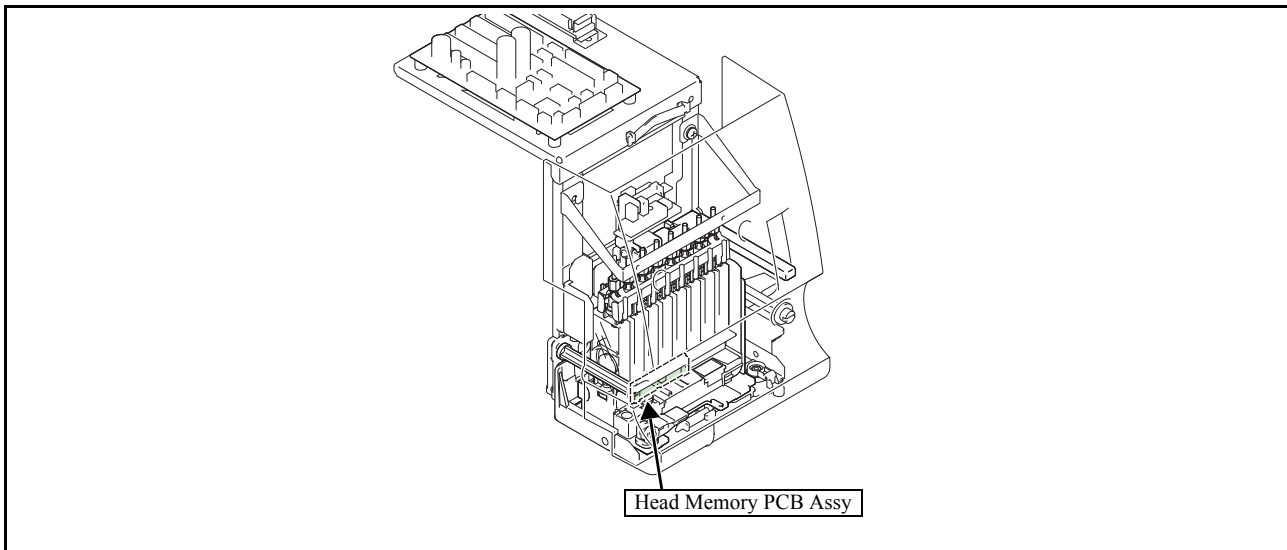

1

2

3

4

5

6

7

8

Work procedures



After turning off the sub and main power switches in order, unplug the power code.
Check if no electric charge is remaining in the PCB.

Refer to the "4.5.2 Electric charge checking when replace the Electrical Parts"

It is very dangerous if sleep mode functions mistakenly during the operation.

Moreover, the PCB may be damaged in case electric charge still remains inside.

Also there is a possibility of electric shock because of high power voltage applied the high-pressure part of the power supply PCB assy. Take care to avoid contact with it.

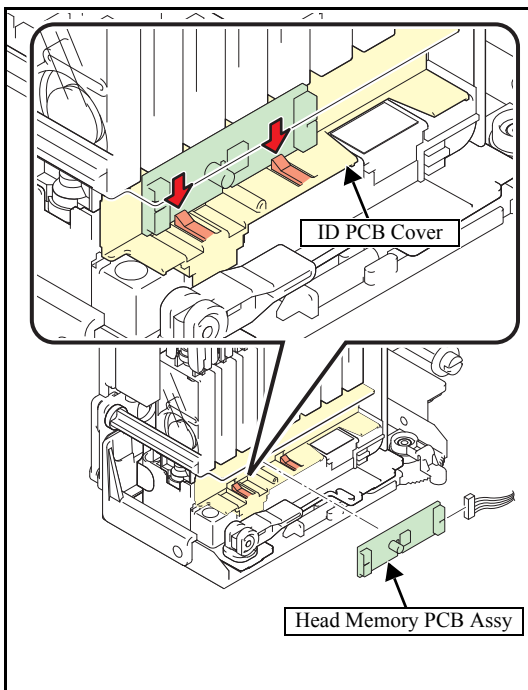

1. Remove the following covers.

- Front Cover
- Print Head Cover

2. Move the head unit on the platen.

3. Release the hook of the ID PCB cover, remove the head memory PCB assy and then disconnect all the cables.

4. Reverse the disassembly procedure for reassembly.

6.5.5 LED PCB Assy

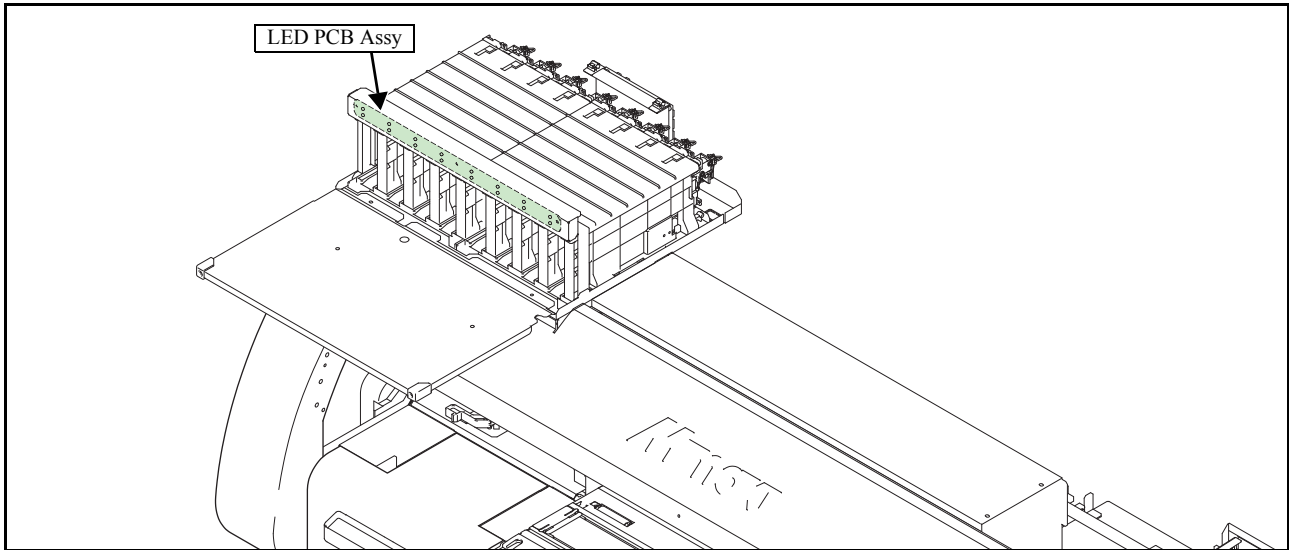

1

2

Work procedures



After turning off the sub and main power switches in order, unplug the power code. Check if no electric charge is remaining in the PCB. Refer to the "4.5.2 Electric charge checking when replace the Electrical Parts" It is very dangerous if sleep mode functions mistakenly during the operation. Moreover, the PCB may be damaged in case electric charge still remains inside. Also there is a possibility of electric shock because of high power voltage applied the high-pressure part of the power supply PCB assy. Take care to avoid contact with it.

3

4

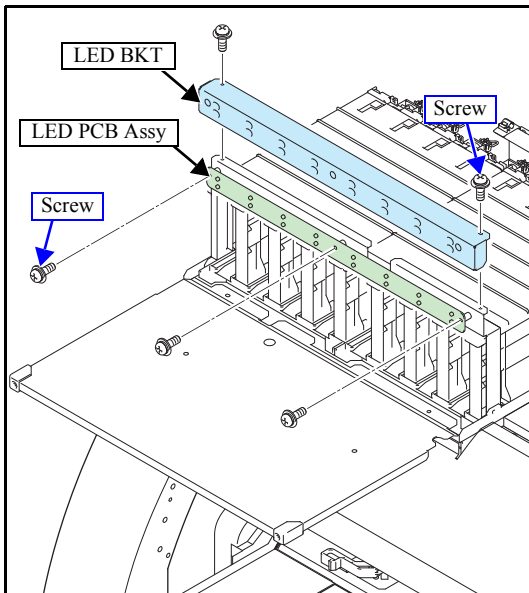

1. Remove the cartridge cover.
2. Remove LED BKT and then LED PCB assy.

5

6

3. Reverse the disassembly procedure for reassembly.

7

8

6.5.6 Station PCB Assy

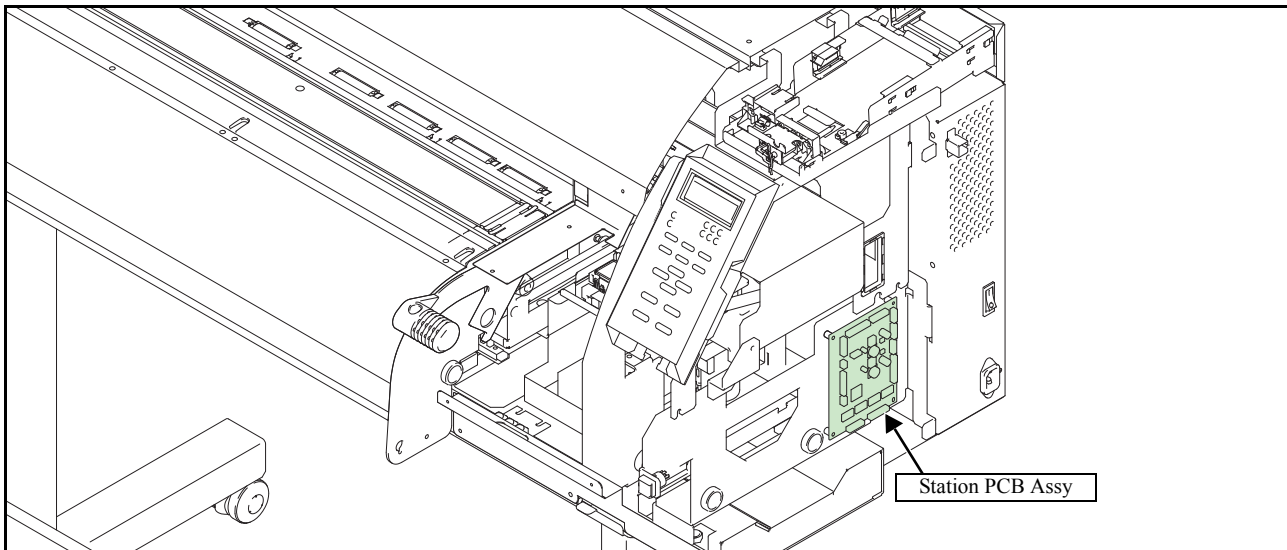

1

2

3

4

5

6

7

8

Work procedures



After turning off the sub and main power switches in order, unplug the power code.
Check if no electric charge is remaining in the PCB.

Refer to the "4.5.2 Electric charge checking when replace the Electrical Parts"

It is very dangerous if sleep mode functions mistakenly during the operation.

Moreover, the PCB may be damaged in case electric charge still remains inside.

Also there is a possibility of electric shock because of high power voltage applied the high-pressure part of the power supply PCB assy. Take care to avoid contact with it.

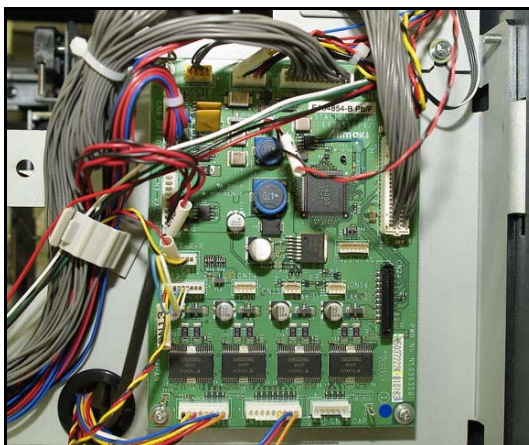

1. Remove the following covers.

- KB Cover
- Right Cover

2. Disconnect all cables from PCB.

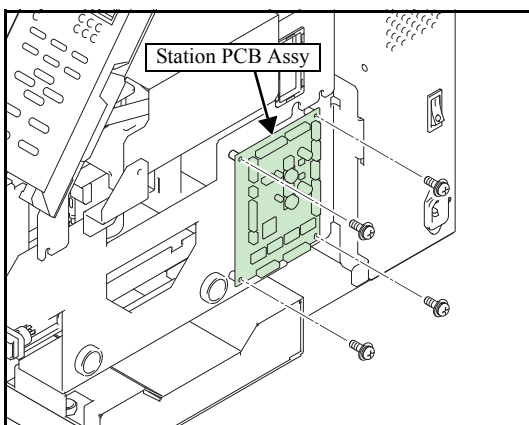

3. Remove the station PCB assy.

4. Reverse the disassembly procedure for reassembly.

6.5.7 Paper Sensor

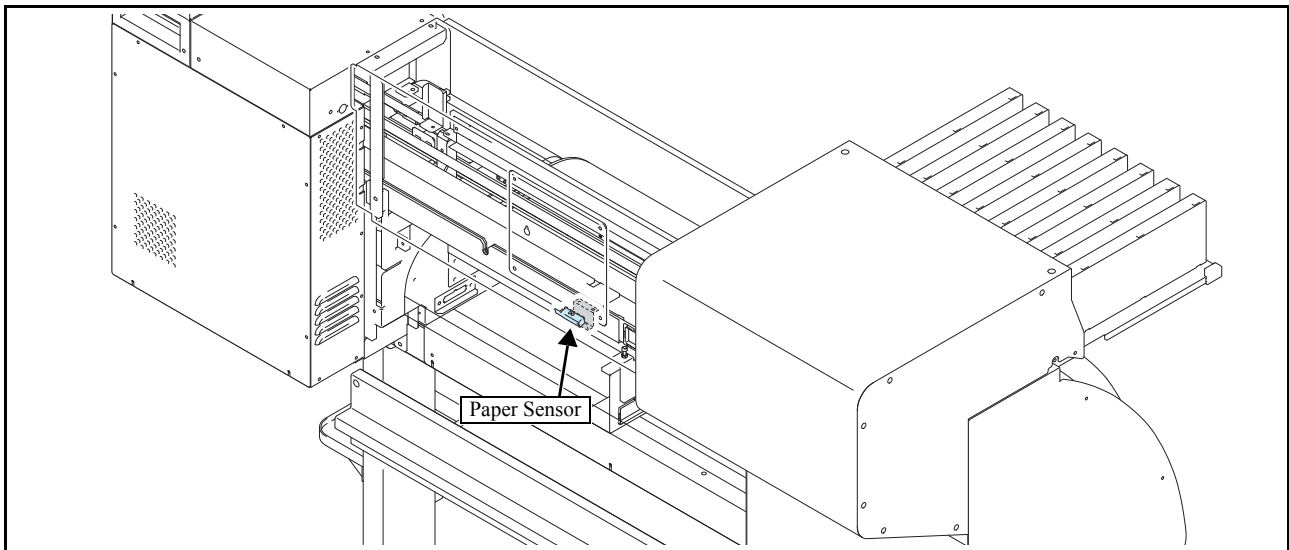

1

2

3

4

5

6

7

8

Work procedures



After turning off the sub and main power switches in order, unplug the power cord.
Check if no electric charge is remaining in the PCB.

Refer to the "4.5.2 Electric charge checking when replace the Electrical Parts"

It is very dangerous if sleep mode functions mistakenly during the operation.

Moreover, the PCB may be damaged in case electric charge still remains inside.

Also there is a possibility of electric shock because of high power voltage applied the high-pressure part of the power supply PCB assy. Take care to avoid contact with it.

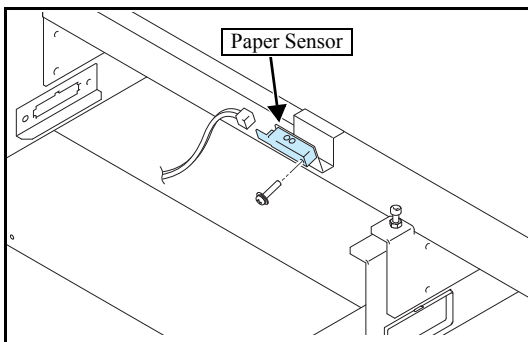

1. Remove the following covers.

- Platen Cover R
- Left cover
- Cartridge cover

2. Disconnect the connector of pre-heater and then remove the platen cover R.

3. Remove the paper sensor and then disconnect the connector.

4. Reverse the disassembly procedure for reassembly.

6.5.8 X-axis Motor Relay PCB Assy

1.1

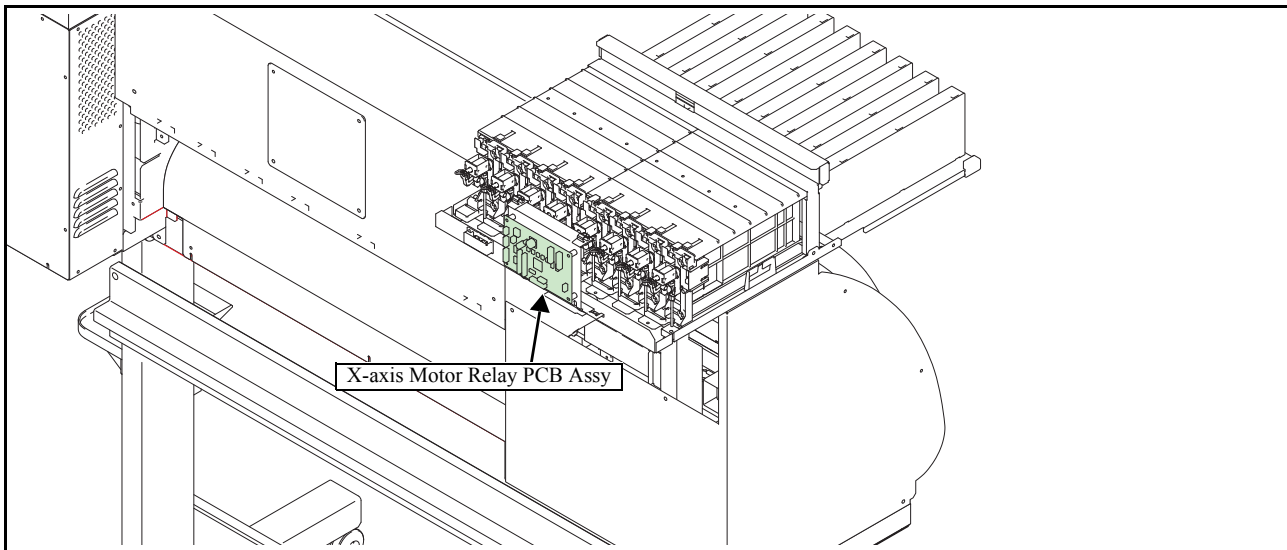

1

2

3

4

5

6

7

8

Work procedures



After turning off the sub and main power switches in order, unplug the power code.
Check if no electric charge is remaining in the PCB.

Refer to the "4.5.2 Electric charge checking when replace the Electrical Parts"

It is very dangerous if sleep mode functions mistakenly during the operation.

Moreover, the PCB may be damaged in case electric charge still remains inside.

Also there is a possibility of electric shock because of high power voltage applied the high-pressure part of the power supply PCB assy. Take care to avoid contact with it.

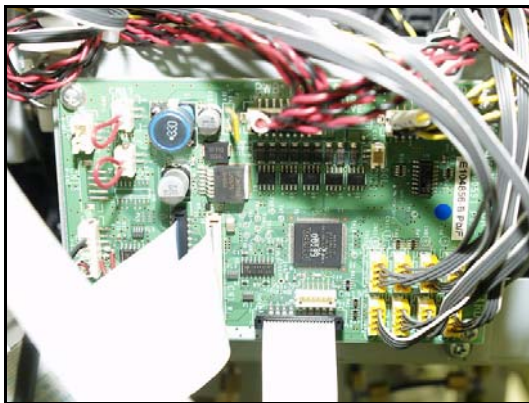

1. Remove the **cartridge cover**.

2. Disconnect all FFCs and connectors from PCB.

6.5.8 X-axis Motor Relay PCB Assy

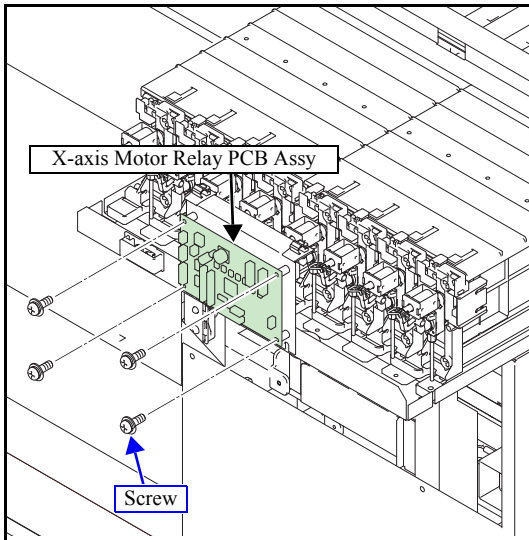

3. Remove the X-axis motor relay PCB assy.

4. Reverse the disassembly procedure for reassembly.

1

2

3

4

5

6

7

8

6.5.9 Ink Slider PCB Assy

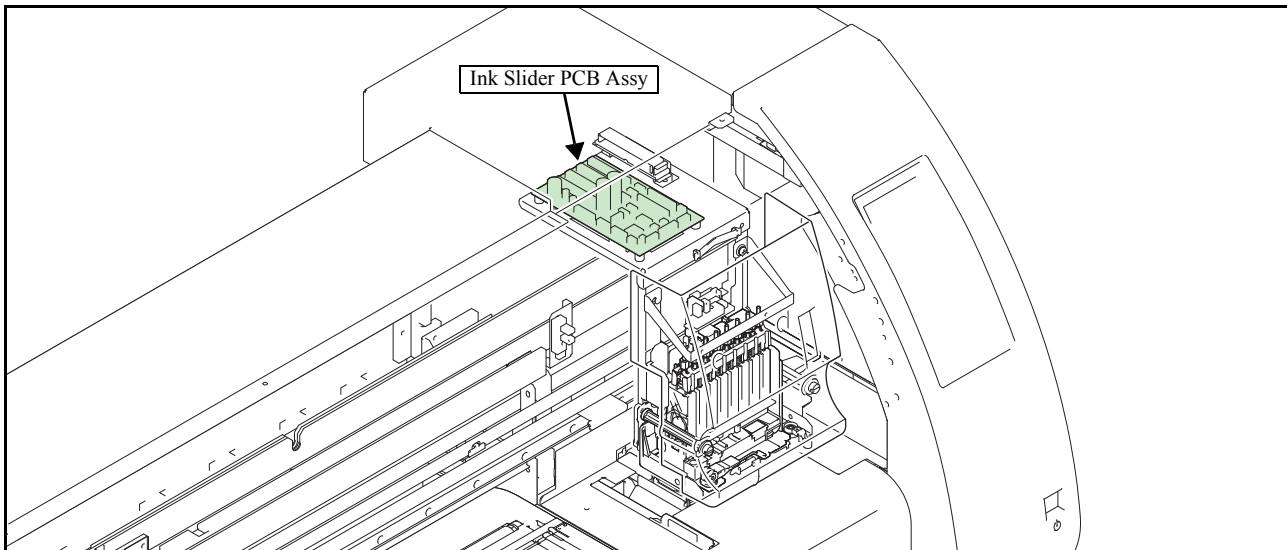

■ Work procedures



After turning off the sub and main power switches in order, unplug the power code.

Check if no electric charge is remaining in the PCB.

Refer to the "4.5.2 Electric charge checking when replace the Electrical Parts"

It is very dangerous if sleep mode functions mistakenly during the operation.

Moreover, the PCB may be damaged in case electric charge still remains inside.

Also there is a possibility of electric shock because of high power voltage applied the high-pressure part of the power supply PCB Assy. Take care to avoid contact with it.



1. Remove the following covers.

- CY Cover F
- Wiring Cover

2. Move the ink carriage onto the station and disconnect all cables from PCB.

1

2

3

4

5

6

7

8

6.5.9 Ink Slider PCB Assy

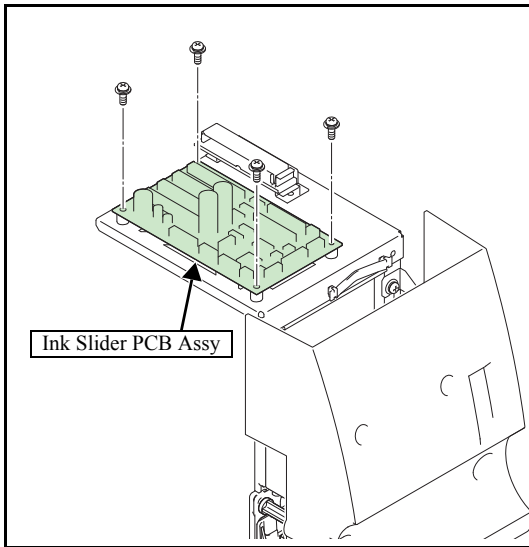

3. Remove the **ink slider PCB assy**.

4. Reverse the disassembly procedure for reassembly.

1

2

3

4

5

6

7

8

6.5.10 Cutter Slider PCB Assy

1.1

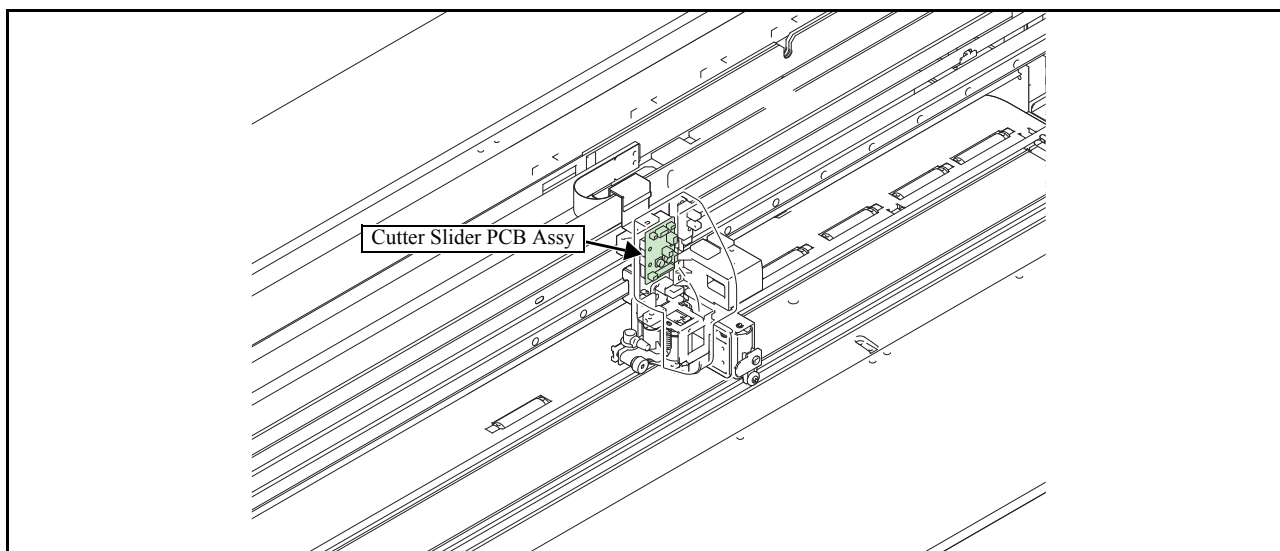

■ Work procedures



After turning off the main power supply switch, make sure to take 15 minutes before restarting the operation. It is very dangerous if sleep mode functions mistakenly during the operation. Moreover, the PCB may be damaged in case electric charge still remains inside.



After turning off the sub and main power switches in order, unplug the power code. Check if no electric charge is remaining in the PCB. Refer to the "4.5.2 Electric charge checking when replace the Electrical Parts" It is very dangerous if sleep mode functions mistakenly during the operation. Moreover, the PCB may be damaged in case electric charge still remains inside. Also there is a possibility of electric shock because of high power voltage applied the high-pressure part of the power supply PCB assy. Take care to avoid contact with it.



1. Remove the **C head cover**.
2. Disconnect all FFCs and cables from PCB.

1

2

3

4

5

6

7

8

6.5.10 Cutter Slider PCB Assy

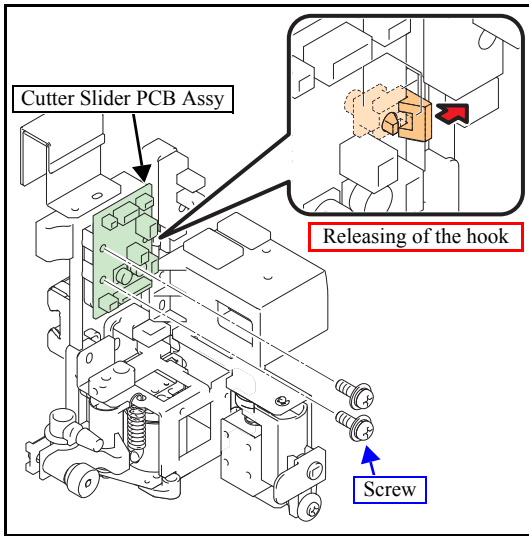

3. Remove the screw, release the hook and then remove cutter slider PCB Assy.

4. Reverse the disassembly procedure for reassembly.

1

2

3

4

5

6

7

8

6.5.11 Keyboard PCB Assy

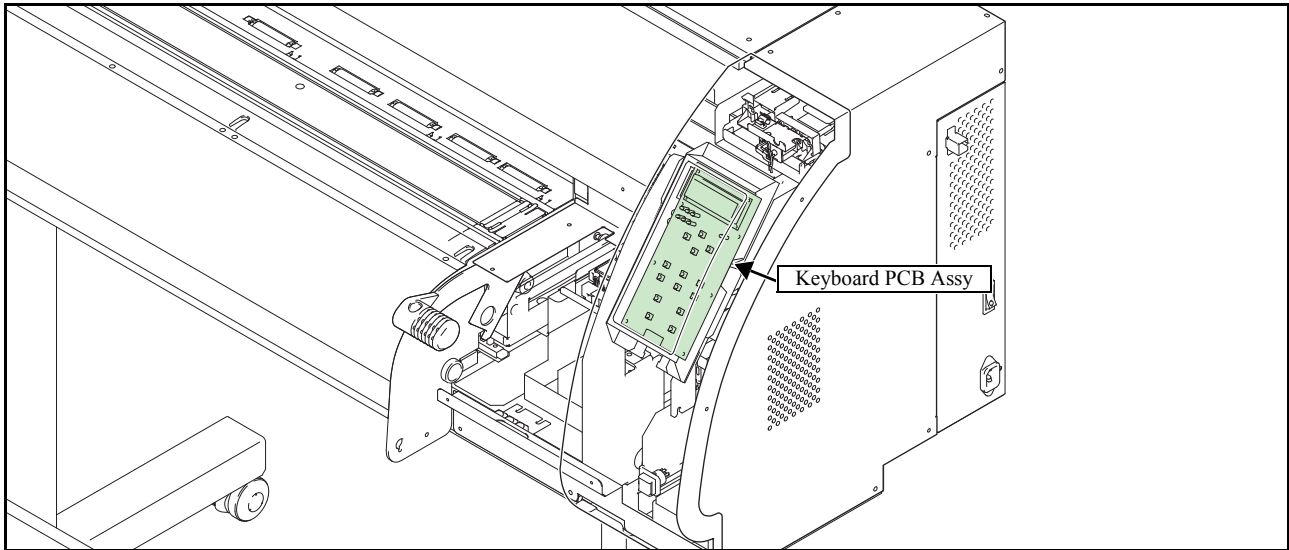

1

2

3

4

5

6

7

8

■ Work procedures



After turning off the sub and main power switches in order, unplug the power code.
Check if no electric charge is remaining in the PCB.

Refer to the "4.5.2 Electric charge checking when replace the Electrical Parts"

It is very dangerous if sleep mode functions mistakenly during the operation.

Moreover, the PCB may be damaged in case electric charge still remains inside.

Also there is a possibility of electric shock because of high power voltage applied the high-pressure part of the power supply PCB Assy. Take care to avoid contact with it.

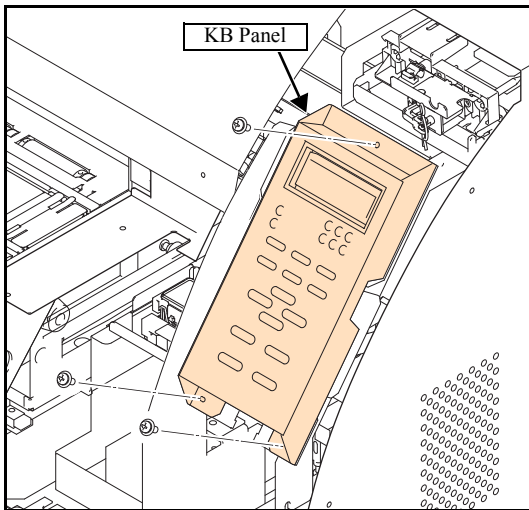

1. Remove the **KB cover**.

2. Disconnect the cable from PCB and then remove the KB panel.

6.5.11 Keyboard PCB Assy

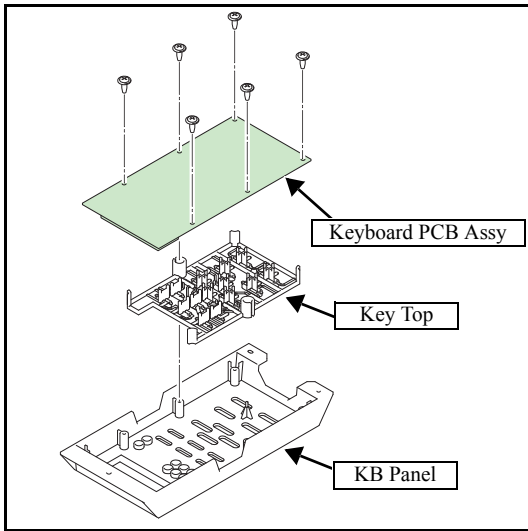

3. Remove the keyboard PCB assy.

4. Reverse the disassembly procedure for reassembly.

1

2

3

4

5

6

7

8

6.5.12 Encoder PCB Assy

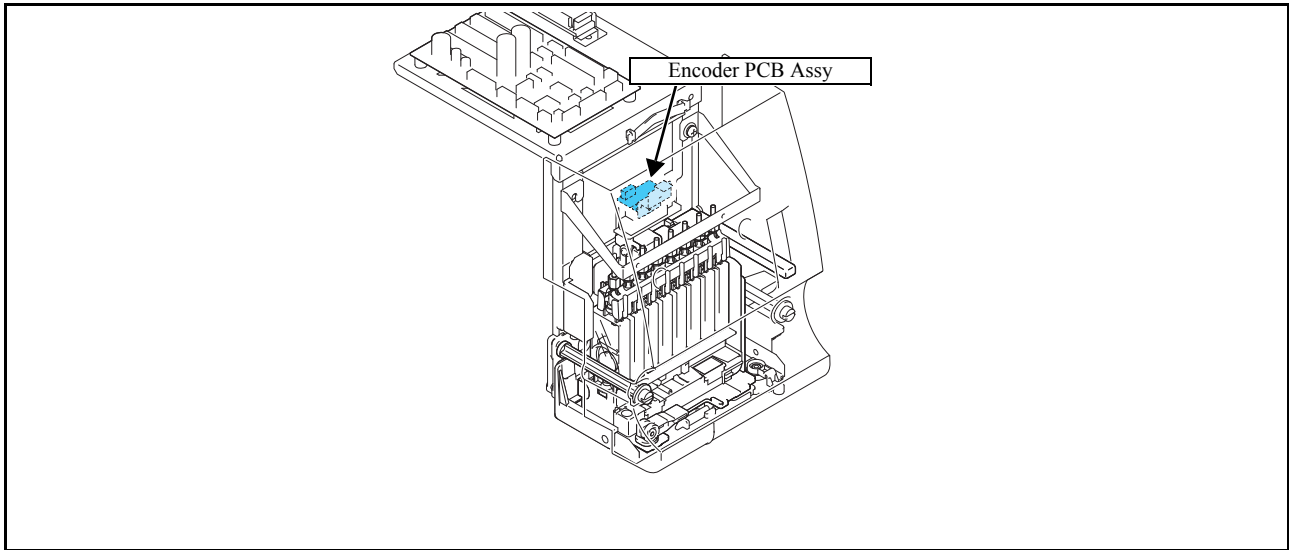

Work procedures



After turning off the sub and main power switches in order, unplug the power code.
 Check if no electric charge is remaining in the PCB.
 Refer to the "4.5.2 Electric charge checking when replace the Electrical Parts"
 It is very dangerous if sleep mode functions mistakenly during the operation.
 Moreover, the PCB may be damaged in case electric charge still remains inside.
 Also there is a possibility of electric shock because of high power voltage applied the high-pressure part of the power supply PCB assy. Take care to avoid contact with it.

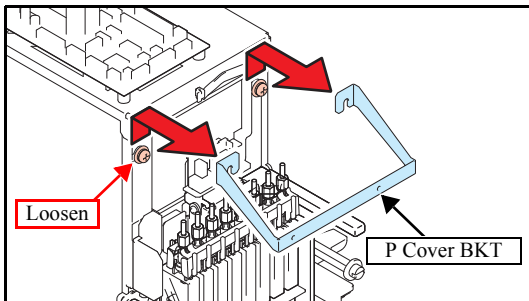

1. Remove the following covers.

- C Y Cover F
- Head Cover

2. Loosen the screws at two locations on the right and left to remove the **P cover BKT**.

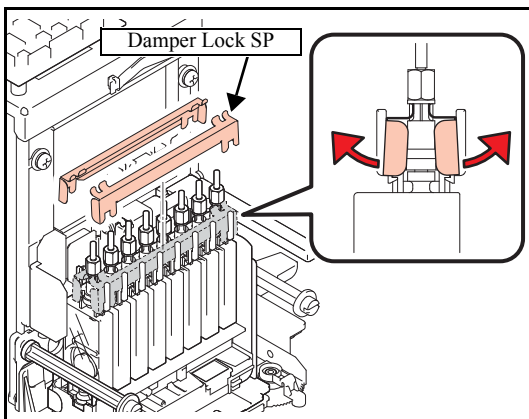

3. Remove **damper lock SPs**.

Near side: Rotate right and left edges towards you and remove them.

Rear side: Rotate right and left edges to the rear and remove them.

1

2

3

4

5

6

7

8

6.5.12 Encoder PCB Assy

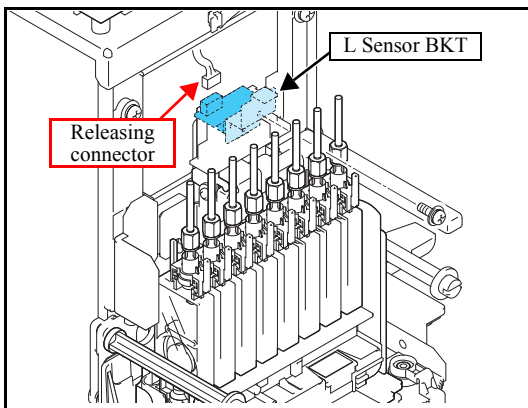

4. Insert a driver through the gap of the damper to loosen the screws, remove the **encoder PCB Assy** together with **L sensor BKT**, and then release the connector.

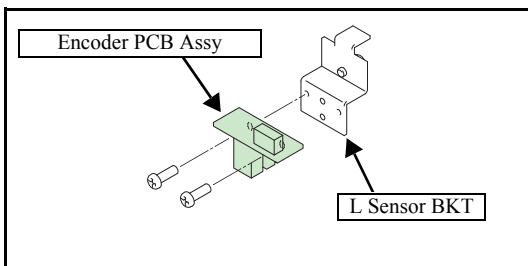

5. Remove the **encoder PCB Assy**.

6. Reverse the disassembly procedure for reassembly.

1

2

3

4

5

6

7

8

6.5.13 Fan Motor

1.0

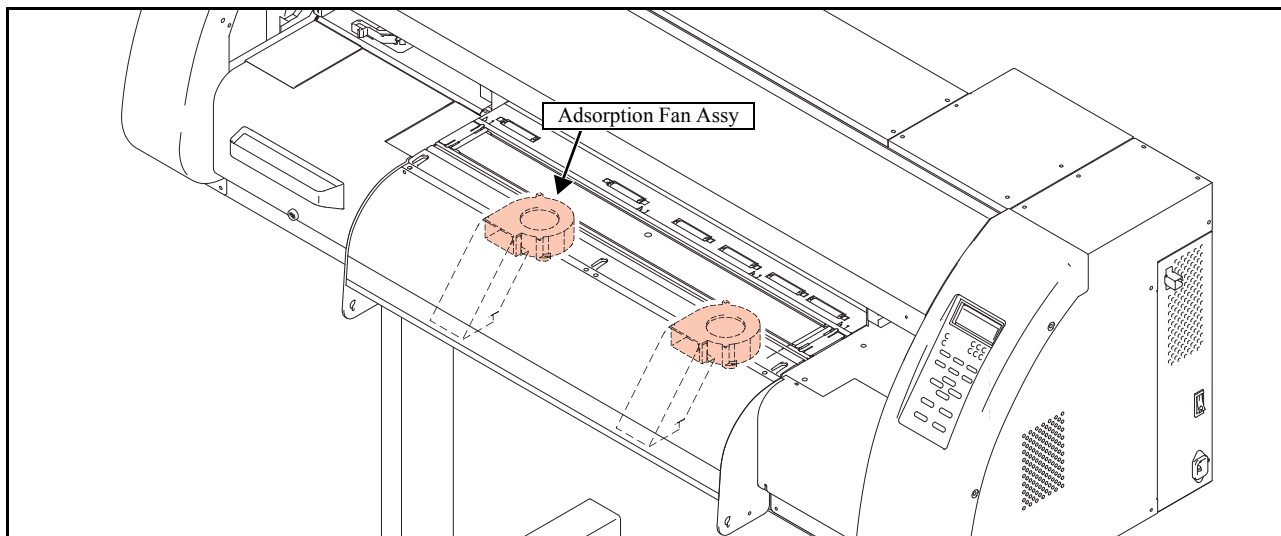

■ Work procedures



Warning

After turning off the sub and main power switches in order, unplug the power code.

Check if no electric charge is remaining in the PCB.

Refer to the "4.5.2 Electric charge checking when replace the Electrical Parts"

It is very dangerous if sleep mode functions mistakenly during the operation.

Moreover, the PCB may be damaged in case electric charge still remains inside.

Also there is a possibility of electric shock because of high power voltage applied the high-pressure part of the power supply PCB assy. Take care to avoid contact with it.



1. Remove the following covers.

- C Y Cover F
- Cartridge Cover
- Maintenance Cover L
- Left Cover
- Left Station Cover
- Heater Connector Cover
- MS Cover 2
- MS Cover 1

2. Remove the connector of pre-heater and print heater and then remove the **platen cover R**, **platen C30** and **platen F**.

3. Remove the **FAN duct V1** by lifting it obliquely.

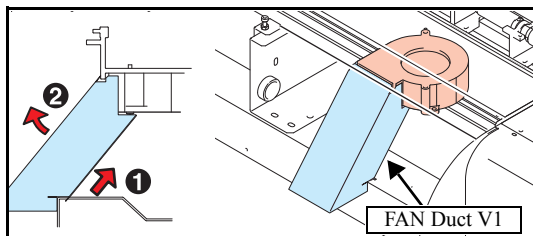

6.5.13 Fan Motor

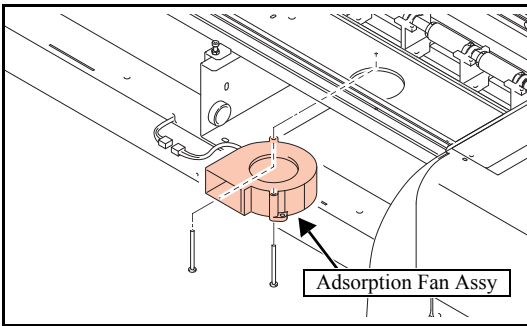

4. Remove the screws with a ratchet or stubby screwdriver, disconnect the connector and remove the **adsorption fan assy**.

5. Reverse the disassembly procedure for reassembly.

1

2

3

4

5

6

7

8

6.5.14 Take-up Motor PCB Assy

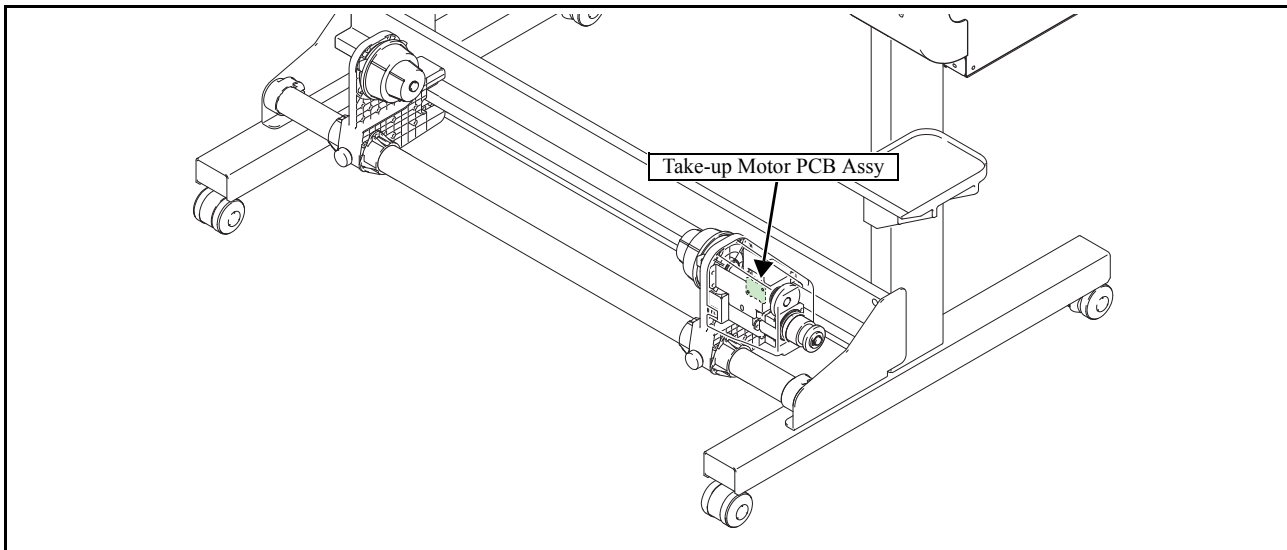

1

2

3

4

5

6

7

8

■ Work procedures



Warning

After turning off the sub and main power switches in order, unplug the power code.
Check if no electric charge is remaining in the PCB.

Refer to the "4.5.2 Electric charge checking when replace the Electrical Parts"

It is very dangerous if sleep mode functions mistakenly during the operation.

Moreover, the PCB may be damaged in case electric charge still remains inside.

Also there is a possibility of electric shock because of high power voltage applied the high-pressure part of the power supply PCB Assy. Take care to avoid contact with it.

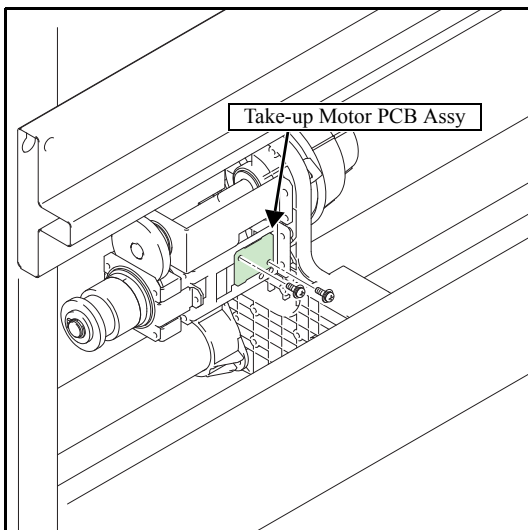

1. Remove the **take-up cover (S)**.

2. Disconnect all connectors and then remove the **take-up motor PCB SK Assy**.

3. Reverse the disassembly procedure for reassembly.

6.5.15 ID Contact PCB Assy

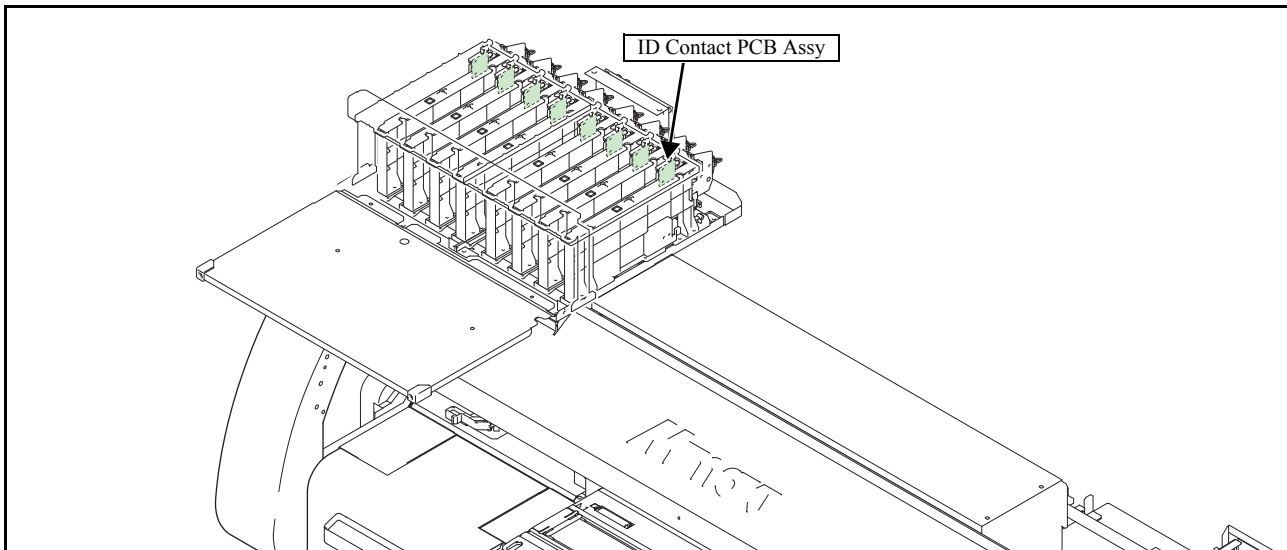

1

2

3

4

5

6

7

8

Work procedures



After turning off the sub and main power switches in order, unplug the power code.
Check if no electric charge is remaining in the PCB.

Refer to the "4.5.2 Electric charge checking when replace the Electrical Parts"

It is very dangerous if sleep mode functions mistakenly during the operation.

Moreover, the PCB may be damaged in case electric charge still remains inside.

Also there is a possibility of electric shock because of high power voltage applied the high-pressure part of the power supply PCB assy. Take care to avoid contact with it.

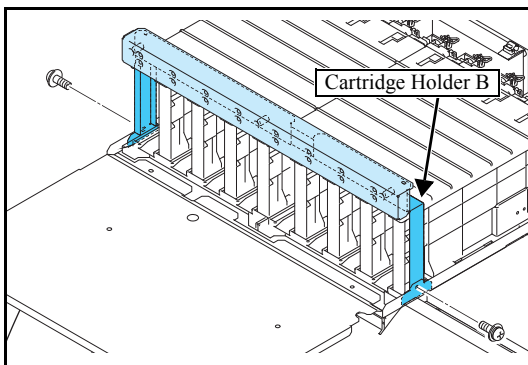

1. Remove the **cartridge cover**.

2. Remove the **cartridge holder B**.



LED PCB FFC is connected. Pay attention to handling.

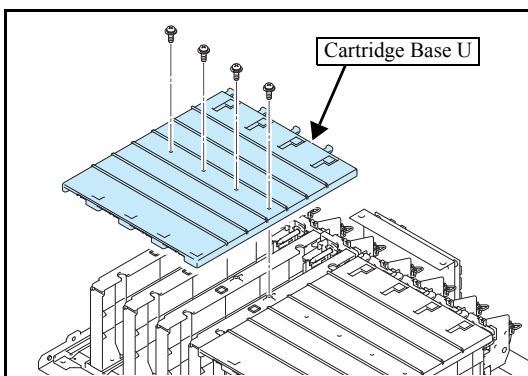

3. Remove **cartridge base U** related to the right or left side.

6.5.15 ID Contact PCB Assy

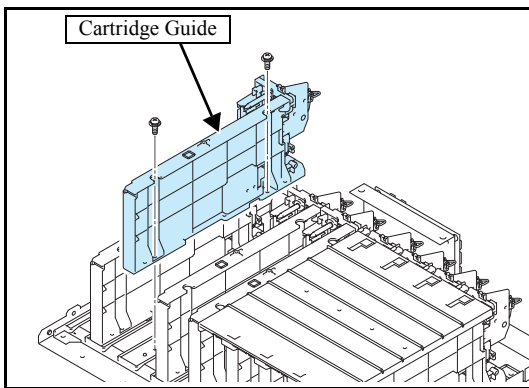

4. Remove the relevant **cartridge guide**.

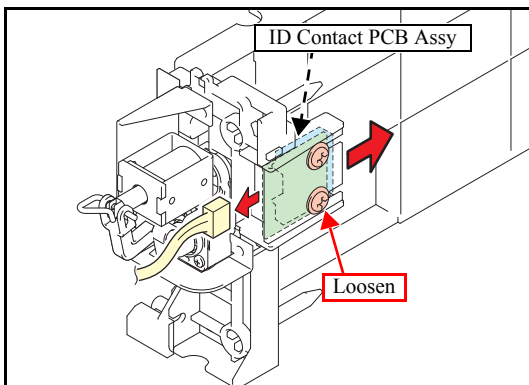

5. Remove the connector and loosen the screws to take off the **ID contact PCB assy** together with ID PCB holder.

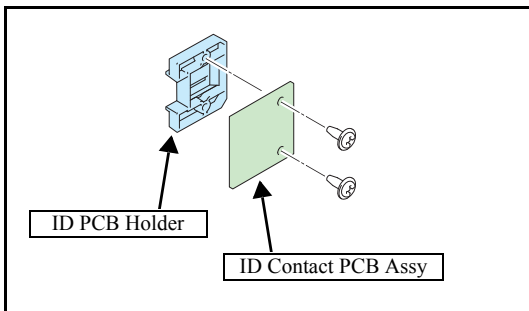

6. Remove the **ID contact PCB assy**.

7. Reverse the disassembly procedure for reassembly.

1

2

3

4

5

6

7

8

6.5.16 Detector Assy, I/C, Y

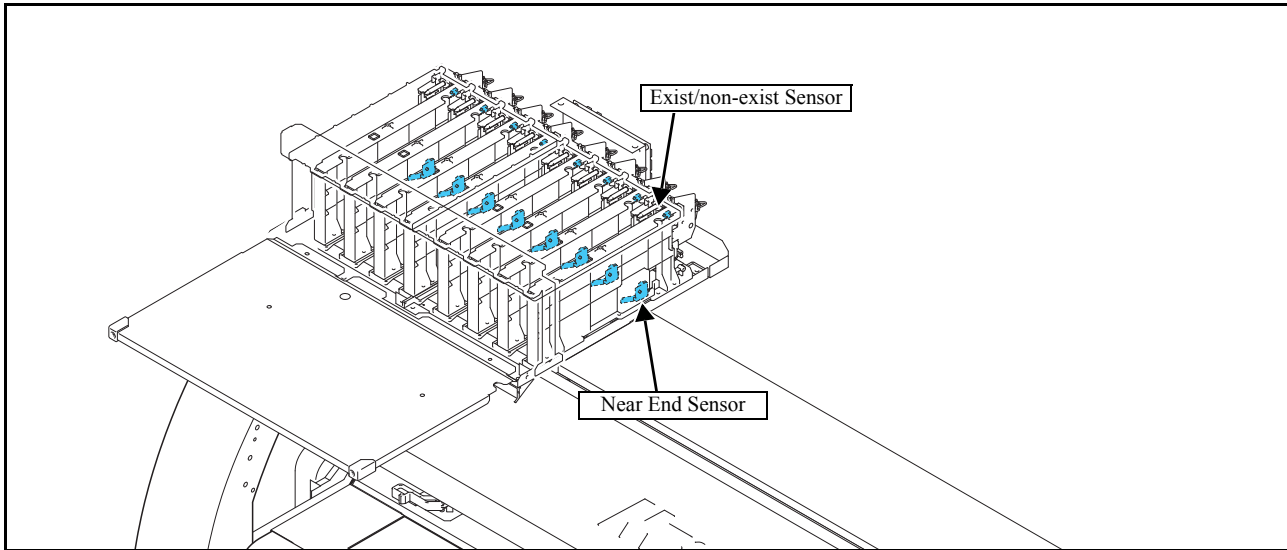

■ Work procedures



After turning off the sub and main power switches in order, unplug the power code.
Check if no electric charge is remaining in the PCB.

Refer to the "4.5.2 Electric charge checking when replace the Electrical Parts"

It is very dangerous if sleep mode functions mistakenly during the operation.

Moreover, the PCB may be damaged in case electric charge still remains inside.

Also there is a possibility of electric shock because of high power voltage applied the high-pressure part of the power supply PCB assy. Take care to avoid contact with it.

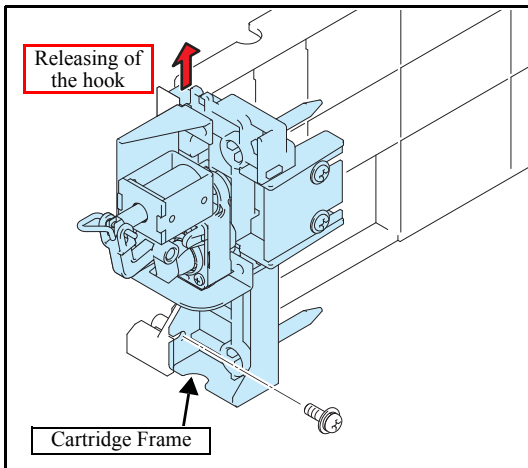

1. Remove the relevant **cartridge guide**.

- See [?6.5.15 ID Contact PCB Assy?](#).

2. Remove the screw, release the hook and then remove **cartridge frame**.

1

2

3

4

5

6

7

8

6.5.16 Detector Assy, I/C, Y

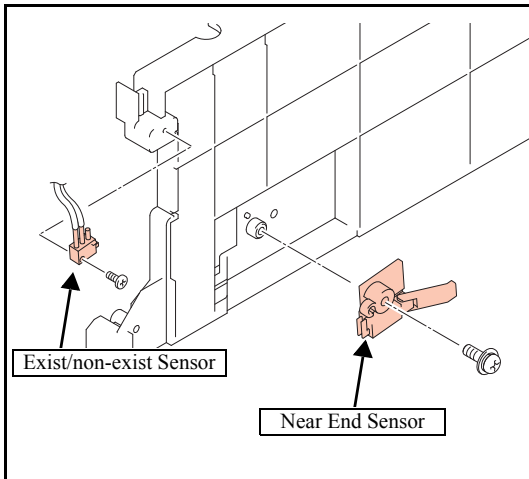

3. Remove the **detector assy, I/C, Y** from the cartridge guide.

4. Reverse the disassembly procedure for reassembly.

1

2

3

4

5

6

7

8

6.5.17 Replacement procedure for fuse of the Main PCB

1.0

■ Outline

Fuse F13 of the Main PCB may blowout when [Error205 47V HEAD VOLTAGE] occurred.

When fuse F13 has blown out after operate "5.2.3 Checking Damage of the Main PCB ASSY", follow the directions below to replace the fuse.



Precaution: Make sure to follow the flow at "7.2.3 Electrical Troubleshooting" first and then replace the fuse.

1

■ Work procedures



After turning off the sub and main power switches in order, unplug the power code.

Check if no electric charge is remaining in the PCB.

Refer to the "4.5.2 Electric charge checking when replace the Electrical Parts"

It is very dangerous if sleep mode functions mistakenly during the operation.

Moreover, the PCB may be damaged in case electric charge still remains inside.

Also there is a possibility of electric shock because of high power voltage applied the high-pressure part of the power supply PCB assy. Take care to avoid contact with it.

2

3

4

5

6

7

8

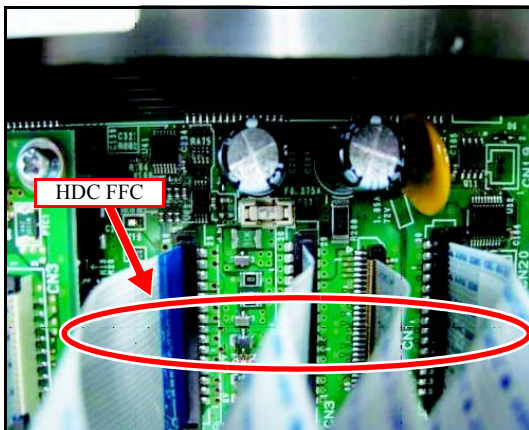

1. Remove the **Power Box Cover**.

2. Check if no electric charge is remaining in the PCB.

- Refer to the "4.5.2 Electric charge checking when replace the Electrical Parts".

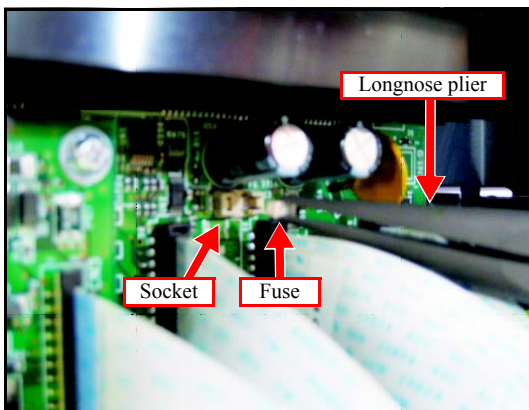

3. Remove the fuse from socket using longnose plier.



Be sure not to remove the fuse too strong.

Also be careful not to break electric parts or cables around the fuse.

6.5.17 Replacement procedure for fuse of the Main PCB

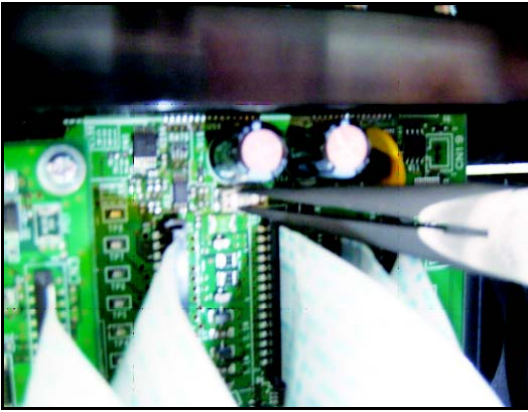

4. Fix the new fuse to the socket using longnose plier.



Check if the fuse is set in proper position of the socket while visual checking and touching with fingers.

1

2

3

4

5

6

7

8

1

2

3

4

5

Disassembly and Reassembly

6

**6.1
Covers**

**6.2
Ink-related Parts**

**6.3
Cut Head Carriage**

**6.4
Drive System**

**6.5
Electrical Parts**

**6.6
Sensors**

7

8

6.6.1 Sensor Layout

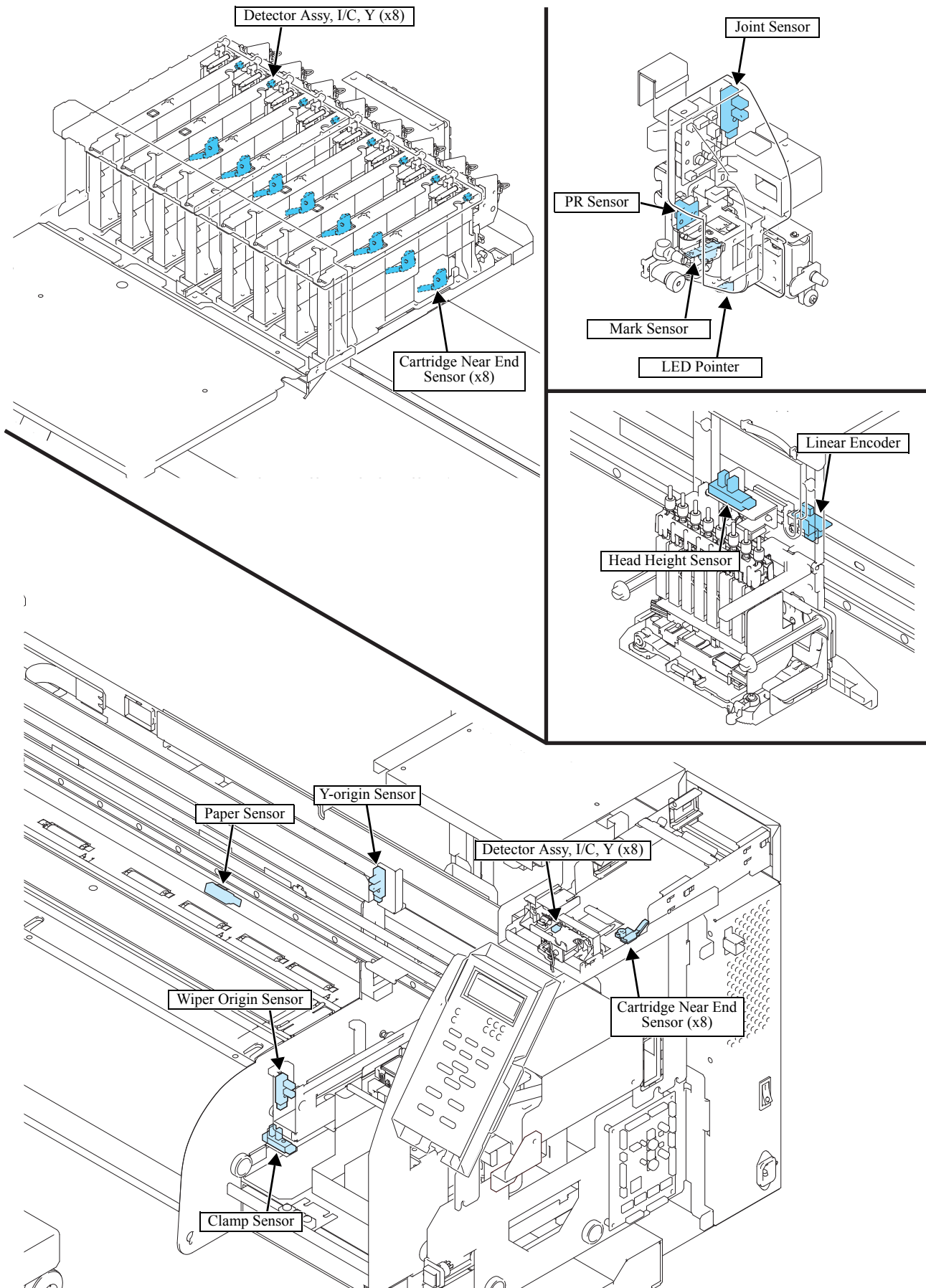

1

2

3

4

5

6

Troubleshooting

**7.1
Details on Errors and Malfunctions**

**7.2
Detailed Methods of Coping with
the Malfunctions**

**7.3
Checksheet**

7

8

7.1.1 Concerning Errors and Malfunctions

1.1

■ Outline

This chapter describes the troubleshooting for this machine.

■ Rough identification of the source of the trouble

At the beginning of troubleshooting, it is necessary to identify roughly which functions the trouble relates to.

Problems can be roughly classified into those that relate to the plotter itself and those that involve the connection between the plotter and the host computer.

Problems with the plotter itself

The cause of the trouble can be identified by executing appropriate functions or using test functions.

Problems concerning the connection to the host computer

Hardware: Broken wire or faulty contact of cables

Software: Transmission by improper application setting



In the standard setting of this machine, priority is given to the host computer.
Check the settings on the host computer to see if there is any improper parameter setting.

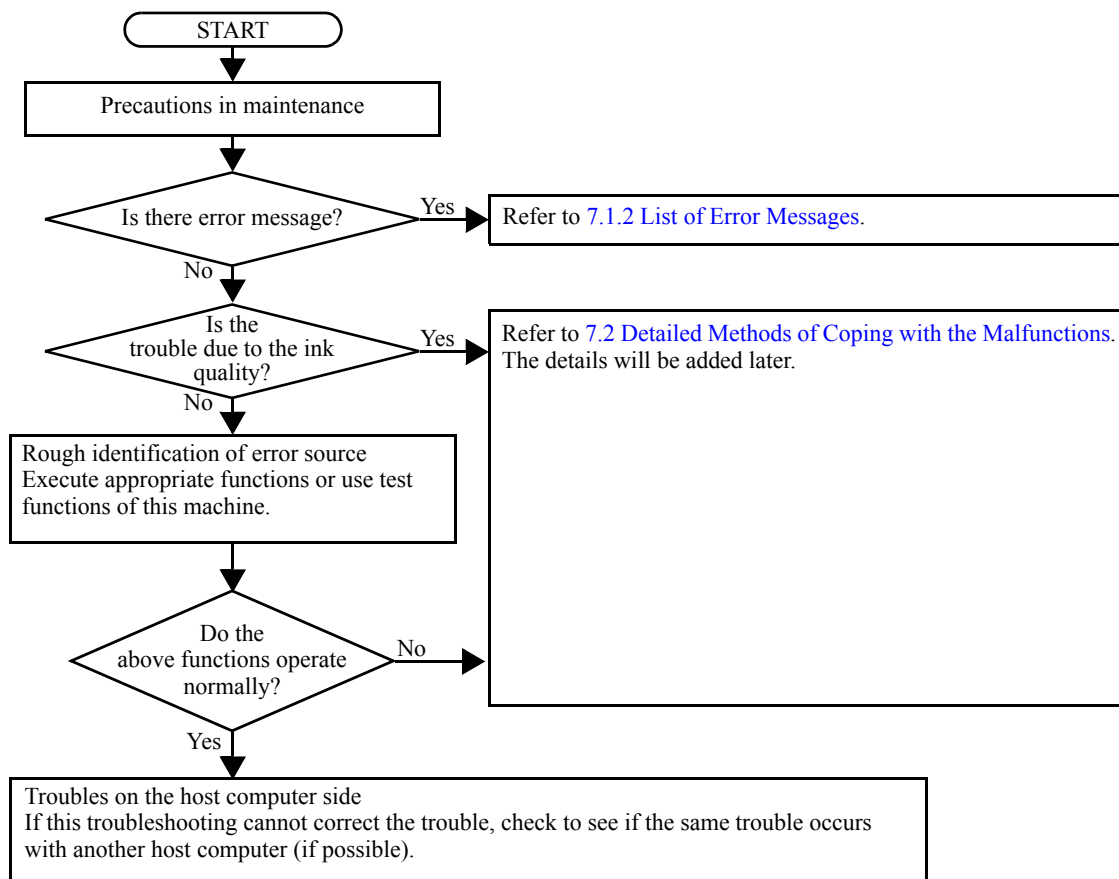

1

2

3

4

5

6

7

8

7.1.1 Concerning Errors and Malfunctions

■ Checking procedure

This section describes troubleshooting procedures for the problems for which error messages are displayed.

1. Identifying the error category

The causes of errors can be classified into the following categories:

- Handling error on the host computer side
- Trouble on the host computer side
- Trouble with the interface cable
- Printer handling error
- Printer mechanical trouble
- Printer hardware trouble
- Printer firmware trouble

2. Initial action

Refer to the error message, and judge whether the trouble lies on the host computer side or on the printer side.

- Has any of the interface conditions (printer model setting, command, communication conditions, etc.) been changed?
- Does the trouble occur under specific conditions?
- Does the same trouble occur repeatedly?

3. Failure on the printer side

Take the following steps to repair the printer.

- Replace the defective part (sensor, etc.) or make the necessary adjustment.
- Replace the main PCB assy.

4. Repair at the factory

If the error recurs even after the corrective measures specified here are taken, return the plotter to the factory of MIMAKI for repair.

1

2

3

4

5

6

7

8

7.1.2 List of Error Messages

■ List of error messages (1/6)

Error No.	Indication on LCD	Cause	Remedy
01	***** ERROR 01 ***** MAIN ROM	An error occurs on the control PCB (ROM)	Turn off the main power, and turn it on a little later. If the error occurs again, carry out the followings.
02	***** ERROR 02 ***** MAIN RAM	An error occurs on the control PCB (RAM)	1. Replace the main PCB Assy. (See 3.4.1)
03	***** ERROR 03 ***** POWER +5V	An error occurs on the control PCB (Power voltage +5V)	Turn off the main power, and turn it on a little later. If the error occurs again, carry out the followings. 1. Replace the power supply PCB Assy. (See 6.5.1) 2. Replace the main PCB Assy. (See 3.4.1)
	***** ERROR 03 ***** POWER +24V	An error occurs on the control PCB (Power voltage +24V)	
	***** ERROR 03 ***** POWER +42V	An error occurs on the control PCB (Power voltage +42V)	
04	***** ERROR 04 ***** F-ROM	An error occurs on the control PCB (Parameter ROM)	Turn off the main power, and turn it on a little later. If the error occurs again, carry out the followings. 1. After uploading parameters, initialize all parameters. If the state is not restored, replace the main PCB Assy with a new one. (See 3.4.1)
06	***** ERROR 06 ***** SD-RAM	An error occurs on the control PCB (SDRAM)	Turn off the main power, and turn it on a little later. If the error occurs again, carry out the followings. 1. Replace the main PCB Assy. (See 3.4.1) 2. Replace the PRAM PCB Assy. (See 6.5.3)
07	***** ERROR 07 ***** HEAD (----)	An error was detected in the head connection. (Abnormal temperature was detected.)	Turn off the main power, and turn it on a little later. If the error occurs again, carry out the followings. Refer to Electrical Troubleshooting (See 7.2.3), and replace the following parts if it has damaged. 1. Replace the head FFC and the HDC FFC cable. 2. Replace the head. 3. Replace the ink slider PCB Assy. (See 6.5.9) 4. Replace the main PCB Assy. (See 3.4.1)
	***** ERROR 07 ***** VOLTAGE (----)	An error was detected in the head connection. (Abnormal voltage was detected.)	
08	***** ERROR 08 ***** LinearENCODER:SENSOR	An error occurred in detection by the linear encoder. (Counting impossible)	Turn off the main power, and turn it on a little later. If the error occurs again, carry out the followings. 1. Check of the mounting location for the linear encoder scale and encoder PCB Assy. 2. Replace the encoder PCB Assy. (See 6.5.12)
	***** ERROR 08 ***** LinearENCODER:DIR.	An error occurred in detection by the linear encoder. (Wrong orientation)	
	***** ERROR 08 ***** LinearENCODER:COUNT	An error occurred in detection by the linear encoder. (Read-out count error)	
09	***** ERROR 09 ***** FPGA ERROR	An error occurs on the control PCB (FPGA PDC)	Turn off the main power, and turn it on a little later. If the error occurs again, carry out the followings. 1. Replace the main PCB Assy. (See 3.4.1)
	***** ERROR 09 ***** HDC ERROR (----)	An error occurs on the control PCB (FPGA HDC)	
10	***** ERROR 10 ***** COMMAND ERROR	Other data than commands is received.	1. Change over the setting of [COMMON SETTING] -> [RECEIVED DATA], depending on the application being used. 2. Clear the data of uncompleted printing. 3. Check the USB cable. (specifications, cable length, etc.) 4. Replace the main PCB Assy. (See 3.4.1)
10C	**** ERROR 10-C **** COMMAND		
11	***** ERROR 11 ***** PARAMETER ERROR	Parameter out of the numeral value range is received.	Turn off the main power, and turn it on a little later. If the error occurs again, carry out the followings. 1. Clear the data of uncompleted printing. 2. Check the USB cable. (specifications, cable length, etc.) 3. Replace the main PCB Assy. (See 3.4.1)
11C	**** ERROR 11-C **** PARAMETER		
12	***** ERROR 12 ***** MAINTENANCE COMMAND	Other data than commands is received.	Turn off the main power, and turn it on a little later. If the error occurs again, carry out the followings. 1. Clear the data of uncompleted printing. 2. Check the USB cable. (specifications, cable length, etc.) Replace the main PCB Assy. (See 3.4.1)

1

2

3

4

5

6

7

8

7.1.2 List of Error Messages

■ List of error messages (2/6)

Error No.	Indication on LCD	Cause	Remedy
12C	**** ERROR 12-C **** DEVICE	Inappropriate instruction was given concerning the printer controlling.	Modify the instruction and send the data again, or send the data after restarting the printer. If the abnormality occurs again, carry out the followings. 1. Clear the data of uncompleted printing. 2. Check the USB cable. (specifications, cable length, etc.) 3. Replace the main PCB assy. (See 3.4.1)
13C	**** ERROR 13-C **** PM OVER	The polygon data exceeded the receive buffer.	Divide the polygon data before sending them.
15C	**** ERROR 15-C **** AUTO FEED	Media feeding cannot be carried out according to the length specified by the data.	Set a longer media and carry out the operation again.
16	**** ERROR 16 **** MRL COMMAND	Received data does not follow the command system set in the printer.	Send the data related to the class of commands, using an application corresponding to this printer. 1. Make sure that the transmission data is in MRL-III command system (data ripped for CJV).
25	**** ERROR 25 **** FULL-SPEED	USB2.0 interface occurred between the host PC and the printer. (Full-Speed Mode connection)	Check whether the host PC is USB2.0 interface-compliant or not. (Though the host PC can be used in either case, use of Hi-Speed Mode connection is recommended.)
	**** ERROR 25 **** PACKET SIZE OVER	USB2.0 interface occurred between the host PC and the printer.	1. Make sure that the connection to the host PC is correct. 2. Make sure that there is no occurrence of an error in the host PC or the application runs normally.
	**** ERROR 25 **** USB PROTOCOL	USB2.0 interface occurred between the host PC and the printer.	
	**** ERROR 25 **** USB ENVIRONMENT	USB2.0 interface occurred between the host PC and the printer.	
	**** ERROR 25 **** USB DATA	USB2.0 interface occurred between the host PC and the printer.	
30	**** ERROR 30 **** OPERATION ERROR	Improper operations were performed on the operation panel.	The operation cannot be carried out due to the reason indicated in the second line. Clear the corresponding error and carry out the operation.
31C	**** ERROR 31-C **** NO DATA	[No. COPIES] cannot be carried out due to the absence of data in the receive buffer.	(Refer to the page of [No. COPIES] function in the OPERATION MANUAL.)
32C	**** ERROR 32-C **** DATA TOO BIG	[No. COPIES] cannot be carried out due to the large size of the received data.	
33C	**** ERROR 33-C **** MEDIA SIZE	Media is too short in the length of the feed direction.	Use longer media.
34	**** ERROR 34 **** PRINT DATA REMAIN	Functional settings were changed or an inoperative function was attempted while the printer has already received data and printing of the data has not been completed.	Print all the data received, or clear them all and carry out the operation again from the start. (If uncompleted printing data is remaining, provide an account concerning the operating-condition modification and the inoperative function.)
34C	**** ERROR 34-C **** CUT DATA REMAIN	An inappropriate operation was carried out during the cutting was being suspended by pressing [REMOTE] key.	Wait for the cutting data to be completely carried out or clear the data.
35C	**** ERROR 35-C **** cutNG WIND	Since take-up is executed, auto cutting of media is not performed.	Auto cutting is not performed if take-up timing is set by the roll detection setting function. To give priority to auto cutting, set [TAKEUP TIMING] to OFF.

1

2

3

4

5

6

7

8

7.1.2 List of Error Messages

■ List of error messages (3/6)

Error No.	Indication on LCD	Cause	Remedy
36C	**** ERROR 36-C**** MARK DETECT	The mark cannot be detected. (After the print media detection)	Check the followings. <ul style="list-style-type: none"> Media curling Specified location for starting the mark detection. Is the black mark printed on the white background of the media? Aren't there any unnecessary prints or blots and adhesion of dirt inside the marks? Aren't there any errors in each setting of the mark?
	**** ERROR 36-C **** JOG & <ENT>or<END>	The mark cannot be detected. [MARK DETECT] and [JOG & <ENT>or<END>] are alternately displayed during the copying and cutting of the mark.	During this error, the write pointer stops at the starting point for the mark detection. In case the write pointer position is not in the right place for starting the mark detection, make a position adjustment using the [JOG] key and restart the mark detection by pressing [ENTER]. And also check the followings. <ul style="list-style-type: none"> When using a limp media which is lacking in elasticity or whose width is more than about 800 mm, increase the number of pinch rollers used. When using the limp media, adjust the size of the mark at 8 mm or more on a side, and allocate the marks to be copied 8 mm or more apart from each other. Is the black mark printed on the white background of the media? Aren't there any unnecessary prints or blots and adhesion of dirt inside the marks? Aren't there any errors in each setting of the mark? Since the media may be floated by the use of the media holder, carry out the mark detection without using it.
37C	**** ERROR 37-C **** MARK ORIGIN	As a result of the mark detection, the origin was detected outside the usable plot area.	Arrange the marks within the usable plot area.
38C	**** ERROR 38-C **** MARK SCALE	The mark cannot be detected. [MARK SCALE] and [JOG & <ENT>or<END>] are alternately displayed during the copying and cutting of the mark.	(Refer to ERROR 36-C "JOG & <ENT>or<END>")
40	**** ERROR 40 **** MOTOR ALARM X	Excessive load to the X-motor.	Turn off the main power, and turn it on a little later. If the error occurs again, carry out the followings.
41	**** ERROR 41 **** MOTOR ALARM Y	Excessive load to the Y-motor.	1. Check friction of X (Y) -axis motor.
42	**** ERROR 42 **** X OVER CURRENT	Over current error of X-motor is detected.	2. Check if media attaches on the platen. Media Attachment to the Platen (See 7.2.2) .
43	**** ERROR 43 **** Y OVER CURRENT	Over current error of Y-motor is detected.	3. Replace the X (Y)-axis motor. 4. Replace the regenerative resistivity PCB assy. (See 6.5.2) 5. Replace the main PCB assy. (See 3.4.1)
45	**** ERROR 45 **** CAPPING : PARAMETER	An error occurred in capping control. (Improper parameter adjusted value)	Turn off the main power, and turn it on a little later. If the error occurs again, carry out the followings. <ol style="list-style-type: none"> Make sure that the adjusting value of [#ADJUST] -> [CAPPING] is set correctly.

1

2

3

4

5

6

7

8

7.1.2 List of Error Messages

■ List of error messages (4/6)

Error No.	Indication on LCD	Cause	Remedy
46	**** ERROR 46 **** WIPER	An error occurred in wiper control.	Turn off the main power, and turn it on a little later. If the error occurs again, carry out the followings. 1. Check that the wiper sensor functions properly with [#TEST] -> [SENSOR TEST]. 2. Check that the wiper motor functions properly with [#TEST] -> [MOTOR TEST]. 3. Check whether the guide rail of the wiper is not clogged with ink. (Does the wiper move smoothly?) 4. Replace the wiper sensor. 5. Replace the step motor. (See 6.4.6) 6. Replace the station PCB Assy. (See 6.5.6)
50	**** ERROR 50 **** MEDIA DETECT	Media could not be detected.	Turn off the main power, and turn it on a little later. If the error occurs again, carry out the followings. 1. Carry out [#TEST] -> [SENSOR TEST] -> [PR SENSOR] in this order, and check whether the PR sensor functions normally. 2. Clean the PR sensor, and adjust its mounting position or replace it. 3. Replace the cutter slider PCB Assy. (See 6.5.10)
51	**** ERROR 51 **** Y-ORIGIN	Y-origin could not be detected.	Turn off the main power, and turn it on a little later. If the error occurs again, carry out the followings. 1. Check that the Y-origin sensor functions properly with [#TEST] -> [SENSOR TEST]. 2. Replace the Y-origin sensor. 3. Replace the station PCB Assy. (See 6.5.6)
70	E70 FPGA	FPGA Configuration fails.	(This does not occur during the customer use.) 1. Replace the main PCB Assy. (See 3.4.1)
71	E71 SD-RAM	Abnormal operation in SD-RAM.	(This does not occur during the customer use.) 1. Make sure that PRAM PCB Assy is connected properly. 2. Replace the PRAM PCB Assy. (See 6.5.3) 3. Replace the main PCB Assy. (See 3.4.1)
74	E74 TRANS DATA	Received data is not Version Up file	(This does not occur during the customer use.) 1. Make sure that the ROM file is transmitted.
80	E80 ROM0 ERASE	ROM0 Erase error	(This does not occur during the customer use.) 1. Replace the main PCB Assy. (See 3.4.1)
81	E81 ROM1 ERASE	ROM1 Erase error	
82	E82 h'*****	ROM0 Write error	
83	E83 h'*****	ROM1 Write error	
84	E84 h'*****	Verify error	
85	E85 ROM HASH	Hash check error	
90	E90 h'*****	ROM Erase error	
92	E92 h'*****	ROM Write error	
95	E95 MODE SHIFT	Transition to the version up mode is not allowed.	Adjust the ambient temperature of the printer. Operation under the temperature among the guaranteed operation temperature range is recommended.
99	E99 VERSION DATA	Wrong version data	
120	**** ERROR 120 **** ENVIRONMENT TEMP (LO)	The ambient temperature is outside of the warranty. (The temperature is too low.)	Adjust the ambient temperature of the printer. Operation under the temperature among the guaranteed operation temperature range is recommended.
121	**** ERROR 121 **** ENVIRONMENT TEMP (HI)	The ambient temperature is outside of the warranty. (The temperature is too high.)	
144	**** ERROR 144 **** CARTRIDGE SET !	There are slots where cartridges are not inserted.	Insert cartridges into the slots, since the slots may dry up when left without them inside and the ink may become unusable. Give instruction (to the customers) that, when they leave the slot without cartridge in it, its needle may dry up and becomes unable to absorb the ink.

1

2

3

4

5

6

7

8

7.1.2 List of Error Messages

■ List of error messages (5/6)

Error No.	Indication on LCD	Cause	Remedy
	ERROR COMMAND		(This does not occur during the customer use.) 1. Check the USB cable. (specifications, cable length, etc.)
	ERROR PARAMETER		(This does not occur during the customer use.) 1. Check that PRM file and parameter data correspond to version of the printer.
	ERROR DATA		(This does not occur during the customer use.) 1. Check the USB cable. (specifications, cable length, etc.)
	ERR PRM.SHORTAGE		(This does not occur during the customer use.) 1. Check that PRM file and parameter data correspond to version of the printer.
170	**** ERROR 170 **** CUTTER LOCK	The cutter head cannot be fixed in the standby position, and connector changeover cannot be made.	Turn off the main power, and turn it on a little later. 1. Set cut system parameter No. 37 "CLKAJST" to "0" and turn power on. 2. Check the operation of the C connecting hook or replace it. 3. Check the operation of the change lever or replace it.
	**** ERROR 170 **** PRINT HEAD LOCK	The print head cannot be fixed in the standby position, and connector changeover cannot be made.	Check the operation of the P head connecting hook or replace it.
180	**** ERROR 180 **** CUTTER JOINT	The cutter head or the connector came off during the operation.	Check the vicinity of the connection magnet or replace it.
	**** ERROR 180 **** PRINT HEAD JOINT	The print head or the connector came off during the operation.	Turn off the main power, and turn it on a little later.
181	**** ERROR 181 **** PR POSITION	Media could not be detected. (The location of the pinch roller is not appropriate.)	Set the pinch roller in the proper place.
200	**** ERROR 200 **** HEAD MEMORY (----)	An error occurred in head unit memory.	Turn off the main power, and turn it on a little later. If the error occurs again, carry out the followings. 1. Check the head memory cable. 2. Replace the head memory. 3. Replace the ink slider PCB assy. (See 6.5.9) 4. Replace the main PCB assy. (See 3.4.1)
202	**** ERROR 202 **** DEVICE CONSTRUCTION	Head unconnected. FFC broken or poor connection. An error occurred in head unit memory.	Turn off the main power, and turn it on a little later. If the error occurs again, carry out the followings. 1. Refer to 7.2.3 Electrical Troubleshooting, and replace the following parts if it has damaged. •Check the head and head FFC cable. •Check the HDC FFC cable. •Replace the ink slider PCB assy. (See 6.5.9) •Replace the main PCB assy. (See 3.4.1) 2. Check the head memory cable. 3. Replace the head memory.
203	**** ERROR 203 **** SDRAM SIZE	The printer is not provided with the required size of SD-RAM.	Turn off the main power, and turn it on a little later.
205	**** ERROR 205 **** 47V HEAD VOLTAGE	An excessive current flowed in the 47 V circuit of the print head, thus the fuse was blown.	Refer to Electrical Troubleshooting (See 7.2.3), and replace the following parts if it has damaged. 1. Replace the head FFC and HDC FFC cable. 2. Replace the head. 3. Replace the fuse. (Main PCB F13)(See 6.5.17) 4. Replace the main PCB assy. (See 3.4.1)
206	**** ERROR 206 **** MAIN PCB	The installed main PCB is not the one for CJV.	Replace the main PCB with the one for exclusive use with CJV.

1

2

3

4

5

6

7

8

7.1.2 List of Error Messages

■ List of error messages (6/6)

Error No.	Indication on LCD	Cause	Remedy
207	**** ERROR 207 **** SLEW RATE	Trouble with COM wave	1. Restart 2. Upload event log 3. Report what it happened to SIGN&GRAPHIC, SG DESIGN GROUP
	**** ERROR 207 **** OVERFLOW		
	**** ERROR 207 **** UNDERFLOW		
208	**** ERROR208 **** CHECK MAIN PCB ID	The device type ID of the main PCB is different.	Check the device type ID switch of the main PCB.
211	**** ERROR 211**** HeaterTEMP(--/--/--)	An abnormal temperature of the media heater was detected.	Turn off the main power, and turn it on a little later. If the error occurs again, carry out the followings. 1. Replace the main PCB assy. (See 3.4.1) 2. Replace the power supply PCB assy. (See 6.5.1) 3. Replace the relevant platen cover with a new one.
	**** ERROR 211 **** HeadWARM.TEMP.(----)	An abnormal temperature of the head heating heater was detected.	Turn off the main power, and turn it on a little later. If the error occurs again, carry out the followings. 1. Make sure that the connection to the main FPC is correct. 2. Replace the relevant head heating heater with a new one. 3. Replace the ink slider PCB assy. (See 6.5.9)
	**** ERROR 211 **** HeadWARM.BREAK(----)	The head heating heater is disconnected. * This error is never displayed when no head warm heater is installed.	Turn off the main power, and turn it on a little later. If the error occurs again, carry out the followings. 1. Replace the relevant head heating heater with a new one. 2. Replace the ink slider PCB assy. (See 6.5.9)
	**** ERROR 211 **** HeadWARM.THERM(----)	Trouble has occurred with the thermistor of the head heating heater. * This error is never displayed when no head warm heater is installed.	
250	**** ERROR 250 **** Y COORDINATES	An error was detected during scanning operation.	Turn off the main power, and turn it on a little later. If such an abnormality recurs, check the uploaded parameter and the status of use, then report them to the Development Division.
251	**** ERROR 251 **** SYSTEM ERROR	System error	Turn off the main power, and turn it on a little later. If the error occurs again, carry out the followings. 1. Check whether no abnormality is found by examining the memories (Main.FROM). 2. In case the error recurs, check the uploaded parameter and the status of use, and then report them to the Development Division.

1

2

3

4

5

6

7

8

7.1.3 List of Warning Messages

■ List of Warning Messages (1/3)

No.	Indication on LCD	Cause	Remedy
1	** NO MEDIA **	No media was detected.	If the warning is displayed again even when the media is set, check the followings. 1. Check that the R paper sensor functions properly with [#TEST] -> [SENSOR TEST]. 2. Make sure that the cables are connected properly. 3. Replace the media sensor.
2	!EXCHANGE BATTERY	Exhaustion of RTC battery was detected.	Replace the battery with a new one having the same model number.
3	<LOCAL.1> [#01] !Replace a WIPER	Time to replace the wiper in the capping station with a new one has come. (The wiping count has reached the specified value.)	Check whether the user replaced the wiper. ([MAINTENANCE] -> [ST.MAINTENANCE])
4	<LOCAL.1> [#01] !CONFIRM TEST PRINT	Sleep refresh or cleaning was not performed when power was kept off for 72 hours or more.	Perform TEST DRAW, and check for omitted nozzles. If nozzles are omitted, perform cleaning. If nozzle missing is serious, execute [ST.MAINTENANCE] -> [NOZZLE WASH] for maintenance.
5	PRE PRT AFT BREAK **°C **°C	The media heater is disconnected. (This example shows that preheater is disconnected.)	1. Check that the media heater functions properly with [#TEST] -> [HEATER TEST]. 2. Make sure that the cables are connected properly. 3. Make sure that fuse of power supply PCB assy is not blown out. 4. Replace the power supply PCB assy (<i>See 6.5.9</i>) or main PCB assy (<i>See 3.4.1</i>) with a new one. • The heater PCB assy is for the pre/post heater, and the power supply PCB assy is for the print heater.
6	PRE PRT AFT THERM **°C **°C	The thermistor of a media heater is defective. (This example shows that the thermistor of preheater is defective.)	1. Check that the media heater functions properly with [#TEST] -> [HEATER TEST]. 2. Make sure that connection of thermistor is correct. 3. Replace the main PCB assy. (<i>See 3.4.1</i>)
7	<LOCAL.1> [#01] NEAR END MCKY----	Ink for one supply path has been nearly used up.	Printing is permitted without replacing the ink cartridge (until INK END is displayed). However, the printer returns to local mode every completion of printing one file.
8	*REMOTE.1* [#01] NEAR END MCKY---		
9	<LOCAL.1> [#01] INK END ----KYCM	Ink for one supply path has been completely used up.	Replace the cartridge corresponding to the color displayed.
10	*REMOTE.1* [#01] INK END ----KYCM		
11	<LOCAL.1> [#01] !CARTRIDGE ----KYCM	Ink for one supply path is not yet set, or unusable ink is being set.	Replace or set the cartridges corresponding to the colors displayed.
12	*REMOTE.1* [#01] !CARTRIDGE ----KYCM		
13	<LOCAL.1> !CAR [#01]	There is a problem with installed ink cartridges.	Check the content of the warning by displaying it using the guidance function. LOCAL>[ENTER]>[FUNCTION]
14	*REMOTE.1* !CAR [#01]	Displayed only when 4-color cartridges are installed.	
15	<LOCAL.1> !WSH [#01] *REMOTE.1* !WSH [#01]	There is a problem with the maintenance washing liquid. (Displayed only in cut mode) • Not set. • Any cartridge other than that for maintenance washing liquid is set. • The maintenance washing liquid has been used up.	Replace the maintenance washing liquid cartridge with a new one.
16	<LOCAL.1> !RTN [#01] *REMOTE.1* !RTN [#01]	Periodical operation cannot be executed, since the connection unit is not connected to the print head.	Start origin setting in print mode, and change the connection of the connection unit. Or perform the relevant periodical operation by manual operation.
17	<LOCAL.1> !TNK [#01] *REMOTE.1* !TNK [#01]	The waste ink tank is nearly full. (Displayed only in cut mode)	Replace the waste ink tank with a new one. Execute [MAINTENANCE] -> [InkTankReplace].

1

2

3

4

5

6

7

8

7.1.3 List of Warning Messages

■ List of Warning Messages (2/3)

No.	Indication on LCD	Cause	Remedy
18	<LOCAL.1> !CAR [#01] INK REMAIN K-----	The ink of the 600cc package has been completely used up.	Reset the cartridge and set the amount of remaining ink. If the ink that can be used is remaining, the warning is cancelled and the cartridge can be used continuously. If the ink that can be used is not remaining, the warning is not cancelled.
19	<LOCAL.1> !CAR [#01] REINSERT CARTRIDGE	End sensor is detected with enough ink remaining	Reinstall appropriate cartridge Check or replace the end sensor if it is detected after reinstallation
20	<LOCAL.1> !CAR [#01] !WASTE TANK	The waste ink tank is nearly full. (The waste ink count has reached the specified value.)	Reinstall appropriate cartridge Check or replace the end sensor if it is detected after reinstallation
21	<LOCAL.1> !CAR [#01] !Wash Liquid END	Emptied washing liquid cartridge was detected.	Replace the maintenance washing liquid cartridge with a new one. If the problem still cannot be solved, check the followings.
22	<LOCAL.1> !CAR [#01] !WashLiquidCart.NONE	The washing liquid cartridge has not been installed.	1. Check that the cartridge end sensor works properly with [#TEST] -> [WASH CARTRIDGE]. 2. If it does not work properly, replace the sensor or IO PCB assy with a new one.
23	<LOCAL.1> !CAR [#01] !WRONG WASH CART.	Trouble with washing liquid cartridge has been detected. (Ex.Ink cartridge is set)	Install the maintenance washing liquid cartridge.
24	** Washing liquid ** ** un-filling up. **	Maintenance washing liquid has not been supplied.	Supply the maintenance washing liquid. (Execute [MAINTENANCE] -> [HD.MAINTENANCE] -> [FILL UP INK].)
25	** OFFSCALE **	The cutting data exceeds the effective cutting area. Or the machine has stopped after cutting the media up to its end normally.	Use a larger size of media, decrease the amount of data or execute the divided cutting function.
26	** END COPY **	The machine has terminated copying after completion of one sheet copying, since the data received contains the origin updating command.	The cutting of two or more sheets is not allowed. To have the machine cut two or more sheets, change the setting on the host computer beforehand.
27	** DIVISION ** 5s	The machine has finished the cutting corresponding to a division of the data that exceeds the media width, using the division cut function, and is now waiting for the receipt of the next data.	When the machine does not receive any data from the host computer within ten seconds, it will recognize the data has ended. Then the machine will perform the frame cutting and mark cutting and return to local mode.
28	** END DIVISION **	Displayed in any of the following cases: •Media width is 1 cm or less. •Sample cutting data exceeds the media width. •Two-point axis alignment is set to ON. •Marks have already detected.	Division cutting is not allowed.
29	COPY SKIP	A mark could not be detected during continuous copying. (One pattern is skipped.)	There is no problem if the marks are successfully detected after skipping one pattern. If marks cannot be detected successively by five patterns or more, [ERROR 36-C MARK DETECT] is displayed.
30	PAUSE REM/END	Since [REMOTE] was pressed during mark detection, the detection operation has come to a halt.	Press [REMOTE] again to resume detection operation. Or press [END] to terminate the operation.
31	MEDIA SKEW <ENT>	The deviation of the media exceeded the setting value of SKEW CHECK.	Set the media again and press [ENTER].
32	MEDIA EXCHANGE	Replacing the media is being waited for. (During continuous copying on cut sheets)	Change leaf media (cut sheets) and resume continuous copying.
33	MEDIA END REM/END	The media end was detected during mark detection or during cutting in roll media.	The end of the roll media has been reached, thus cutting cannot be continued. Press [END] and replace the media with new one.
		The media is floating.	Set the media properly so that it is free of floating, and press [REMOTE] to resume cutting.
		A strong light hits the rear of the machine.	Intercept the light, and press [REMOTE] to resume cutting.

1

2

3

4

5

6

7

8

7.1.3 List of Warning Messages

1.3

■ List of Warning Messages (3/3)

Possible to confirm warning below on local guidance

LOCAL> [ENTER](ink remaining quantity is displayed)>[FUNCTION]

No.	Indication on LCD	Cause	Remedy
34	INK NEAR END	Ink in the cartridge is running out.	(Print or use-up cleaning is available)
35	INK END	The ink of the ink cartridge has been completely used up.	(Use-up cleaning is available)
36	NON-ORIGINAL INK	The ink cartridge is not MIMAKI genuine.	Replace the cartridge generating the warning with a new one. If the problem still cannot be solved, check the followings.
37	WRONG INK IC	The IC chip of the ink cartridge cannot be read normally.	<ol style="list-style-type: none"> 1. Check whether the process of [#TEST] -> [INK CARTRIDGE] -> [INK-IC CHECK] can be carried out normally. 2. ID Contact PCB CN032 Assy. (<i>See 6.5.15</i>)
38	Kind of INK	It is different types of ink from the ink filling up with the machine.	Check the ink type of the cartridge generating the warning.
39	Color of INK	It is not the color should be installed.	Check the ink color of the cartridge generating the warning.
40	WRONG CARTRIDGE	There is trouble with an installed ink cartridge.	Check the cartridge generating the warning.
41	NO CARTRIDGE	An ink cartridge has not been installed in the slot.	<p>Install an appropriate ink cartridge in the slot generating the warning. If the problem still cannot be solved, check the followings.</p> <ol style="list-style-type: none"> 1. Check that the cartridge exist/non-exist sensor functions properly with [#TEST] -> [INK CARTRIDGE]. 2. If it does not work properly, replace the sensor or X-axis motor relay PCB assy with a new one.
42	Expiration	The specified expiration date of an ink cartridge has passed.	Make sure if the month of machine is correct on [MACHINE SETUP2]>[TIME SET] if the Warning is displayed within expiry month described on cartridge.
43	Expiration:1MONTH	The specified expiration date of an ink cartridge has passed. (One month has passed after the specified expiration date.)	Refer to 1.3.10 Expiry month and extension of expiry month for ink
44	Expiration:2MONTH	The specified expiration date of an ink cartridge has passed. (Two months have passed after the specified expiration date.)	
45	COMPLETELY EXPIRED	The specified expiration date of ink cartridge has passed. (Six month has passed after the specified expiration date.) Not extend expiry month.	
46	EXPIRED INK IN USE	Cartridge extended expiry month.	
47	INK REMAIN ZERO ----	Remaining amount of ink in an ink cartridge is zero. (Used the prescribed quantity of use-up cleaning.)	Replace the cartridge generating the warning with a new one.
48	REINSERT CARTRIDGE	The end sensor was detected even though enough quantity was remaining.	Install appropriate cartridge. If the warning is not hidden, check or replace the sensor on [#TEST]>[INK CARTRIDGE].
49	Check the "W"nozzle condition. <ENT>	When SS 21 white ink is used, the message of prompting you to perform test printing is displayed for keeping the nozzle status be normal.	Perform "WHITE CHK." of test printing.
50	PERFORM SPOT COLOR MAINTENANCE? <ENT>	When silver and white ink of ES3 ink are used, the message of prompting you to perform special color maintenance for preventing color heterogeneity due to settling down of pigment is displayed.	Perform spot color maintenance.

1

2

3

4

5

6

7

8

7.1.4 Trouble with No Messages

■ Outline

This explains the troubles where no Error nor Warning messages displays.

■ Trouble list

No.	Phenomenon	Contents or Causes	Solution
1	The machine generates strange noise while operating.	1. <input type="checkbox"/> Y belt noise	7.2.1
		2. <input type="checkbox"/> X or Y motor hunting	
2	The power cannot be turned on	1. <input type="checkbox"/> Head, FFC, main PCB, or slider PCB trouble	7.2.3
		2. <input type="checkbox"/> The power supply PCB damage	
		3. <input type="checkbox"/> Poor connection of the connector	
3	Abnormal discharging	1. <input type="checkbox"/> Head, FFC, main PCB, or slider PCB trouble	7.2.3
4	Y belt derailment or damage	1. <input type="checkbox"/> Y-T pulley tilt	7.2.4

1

2

3

4

5

6

7

8

1

2

3

4

5

6

Troubleshooting

7.1
Details on Errors and Malfunctions

7.2
Detailed Methods of Coping with the Malfunctions

7.3
Checksheet

7

8

7.2.1 Y Drive Belt Noise

■ Outline

To ensure the cutting quality, this machine uses the white belt for Y drive with unstretchable and good material in mechanical property.

For the belt, a noise like a metallic sound may be generated due to the friction between the belt edge and the swaging flange of the pulley. To reduce the noise, grease up the belt using specified grease.

It is also effective for Y belt damage.



There is no difference in performance between MG-A1-GU and SEALUB L101. (Checked up to 1500H)
In duration test with a simulated damage, greased machine's durability is more than 12 times higher than no-greased one.

■ Point to be checked

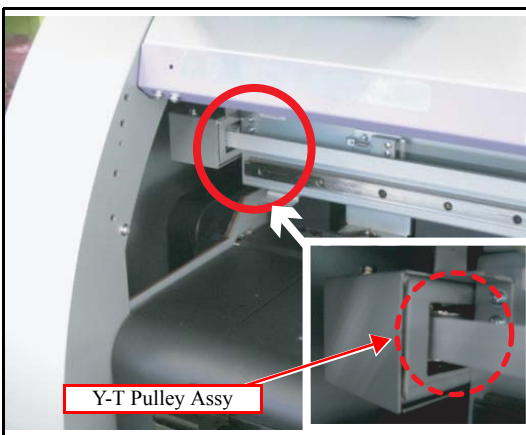

Y-T Pulley Assy

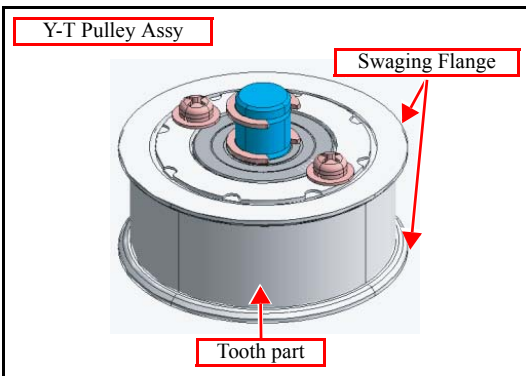

Y-T Pulley Assy

Swaging Flange

Tooth part

1. Check the Y-T Pulley Assy (Y Tension Pulley) condition. Perform [FUNCTION]->[#TEST]->[MOTOR TEST]->[Y SERVO MOTOR], and check there is no deformation on the swaging flange of the pulley while the Y is driving.

2. If the swaging flange seems to move up and down while the Y is driving, or if there is a space between the swaging flange part and the tooth part, the belt may fracture or a problem of the transport function may occur.

3. If no such problems as mentioned above, grease up by following the instruction below "Procedure".

1

2

3

4

5

6

7

8

7.2.1 Y Drive Belt Noise

■ Procedure



Be sure to turn off the main circuit breaker to prevent unexpected movements of the printer.
 At work, make sure not to attach fingerprints or oil or grease to the linear encoder scale and take a great care not to break or scratch it. (If dirt is attached, clean it with mild detergent.)
 In case of using spray grease, the mist may attach to the media. Check there is no media around or on the machine before operation.

□ When using the recommended spray grease [SEALUB L101]



Guideline for Spraying
 Spray the grease while moving the white belt so that the joint unit will move from one end to the other at the speed of 30cm/s.

1

2

3

4

5

6

7

8

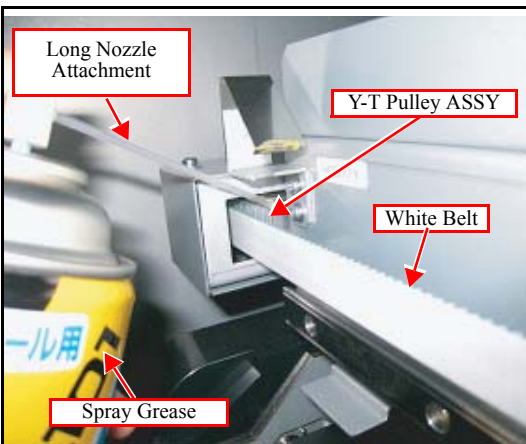

1. Set the long nozzle attachment to the spray grease.
2. Move the joint unit to the left end of the platen.
3. While moving the white belt to the right (rotating the pulley), spray the grease to the Y-T pulley (Y tension pulley).

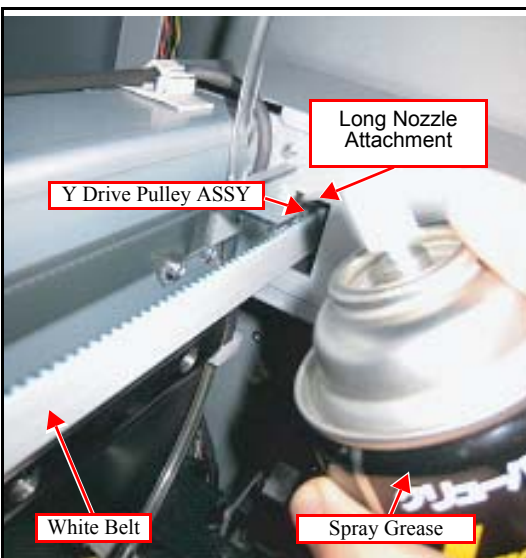

4. When the joint unit reaches the right end, move the white belt to the left and spray the grease to the Y drive pulley.

7.2.1 Y Drive Belt Noise

□ When using MG-A1-GU grease

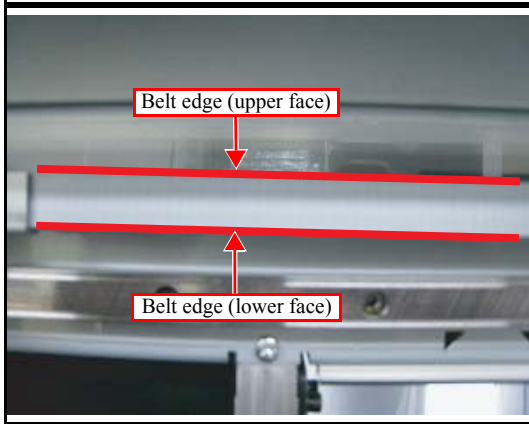
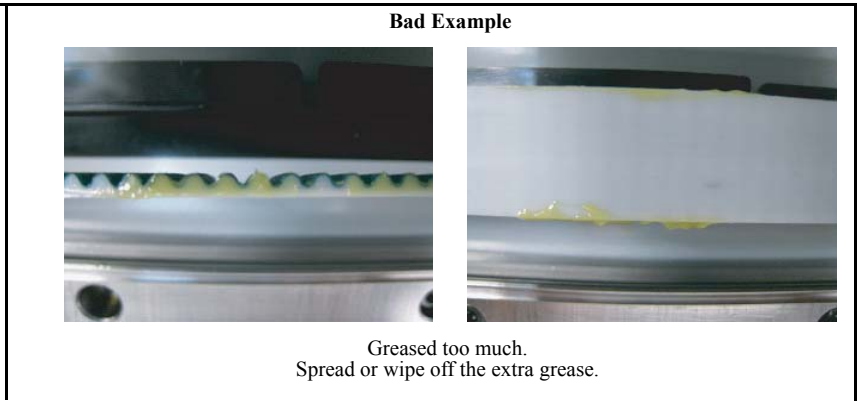
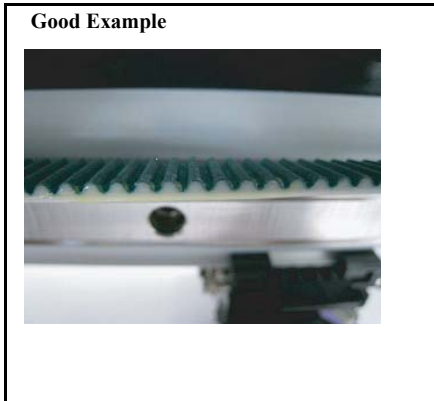

Spread a thin layer of the grease on the whole spreadable area of the white belt edges (on both upper/lower face) with your finger.

Be careful not to spread too much that will spatter the mist of the grease.

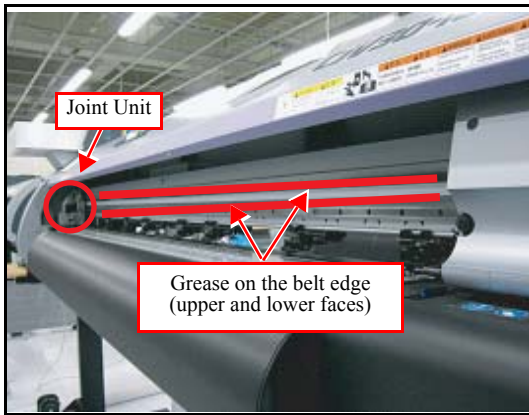

1. Move the joint unit to the left end of the platen.
2. Spread a thin layer of the grease on the upper and the lower faces of the belt with your finger.

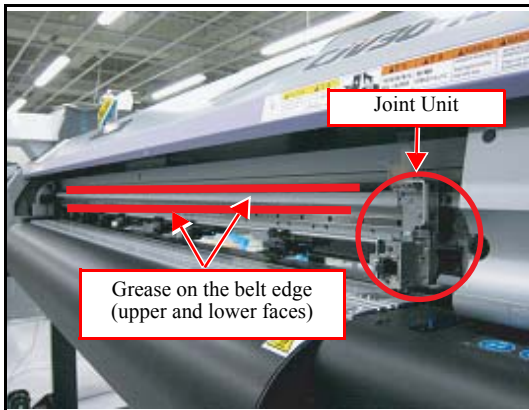

3. Move the joint unit to the right end of the platen.
4. Spread a thin layer of the grease on the upper and the lower faces of the belt with your finger.

1

2

3

4

5

6

7

8

7.2.2 Media Attachment to the Platen

■ Outline

Some media may attach to the platen and cause the X overcurrent error.
To avoid the problem, tape the Niftron tape on to the platen as the following procedures.

■ Tools

- Niftron tape (Model: No.973UL-S 0.13mm x 10mm x 10m, company: NITTO DENKO)
- Scissors
- Ethanol (alcohol) or diluted mild detergent to remove dirt and oil.
- Paper towel to remove dirt and oil. (lint-free towel such as BEMCOT)

■ Procedure



Make sure to turn off the main switch to prevent unexpected movements of the printer.



1. Remove oil on the platen with ethanol or diluted mild detergent.
(Use BEMCOT)

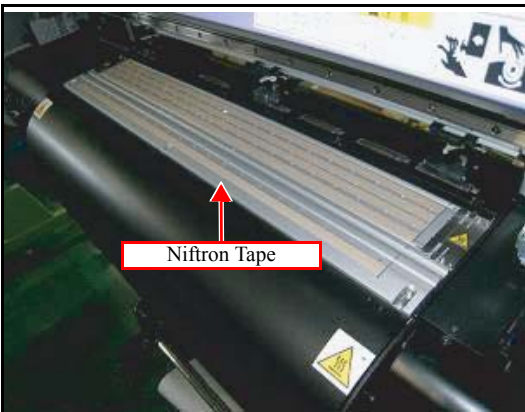

2. Tape the Niftron tape (5 places, cut with scissors) on the platen.



Be careful not to cover the vacuum hole with the tape.
It is acceptable that the tape touches the edge of the hole.

1

2

3

4

5

6

7

8

7.2.2 Media Attachment to the Platen

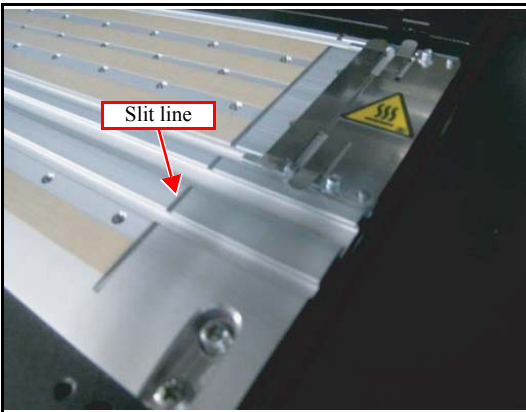
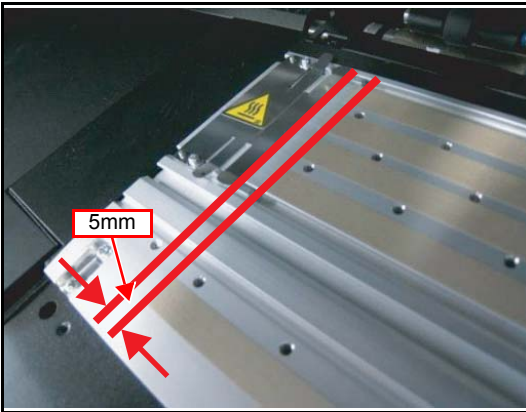

3. To tape the Niftron tape on the left edge of the platen, move the left media retainer to the left end.

4. Tape the Niftron tape, and then cut it at the 5 mm right from the media retainer placed on the left end.

5. To tape the Niftron tape on the right edge of the platen, move the right media retainer to the right end.

6. Tape the Niftron tape, and then cut it along the left end of the slit line.

1

2

3

4

5

6

7

8

7.2.3 Electrical Troubleshooting

1.0

■ Outline

The following errors will be caused by breakage of PCB, and some of them may also break the surrounding PCB by breakage of the head.

This explains the causes and handling for the electrical troubles.

Related troubles :

- Abnormal firing (simultaneously firing of no firing from a certain nozzle line)
- The power would not be turned on
- ERROR 07 HEAD or VOLTAGE
- ERROR 50 MEDIA DETECT or MEDIA POSITION (Only of JV33)
- ERROR 200 HEAD MEMORY
- ERROR 202 DEVICE CONSTRUCTION
- ERROR 205 47V HEAD VOLTAGE (Only of CJV30 and modified JV33 PCB)
- ERROR 207 SLEW RATE or OVERFLOW or UNDERFLOW



After turning off the sub and main power switches in order, unplug the power code.

Check if no electric charge is remaining in the PCB.

Refer to the "4.5.2 Electric charge checking when replace the Electrical Parts"

It is very dangerous if sleep mode functions mistakenly during the operation.

Moreover, the PCB may be damaged in case electric charge still remains inside.

Also there is a possibility of electric shock because of high power voltage applied the high-pressure part of the power supply PCB assy. Take care to avoid contact with it.

■ Causes and solutions of the print head breakage

	Cause of head/PCB damage	Countermeasures
1	Disconnection of HDC_FFC	<p>Fix moving part of the HDC FFC</p> <p>CJV30: Applied to all machines.</p> <p>JV33: Please fix FFC of following machines. Please refer to "JV33 Quality Information No.14" (Japanese only) to fix the FFC.</p> <p>CJV30-130 : from G0704001 to G0805345</p> <p>CJV30-160 : from G1704001 to G1805329</p> <p>Please refer to the documents below for more detail.</p> <ul style="list-style-type: none"> • CJV30 Maintenance Manual (5.2.5 Checking conduction of HDC FFC COM line) • CJV30 Maintenance Manual (5.2.6 Checking conduction of HDC FFC data line)
2	Disconnection of Head FFC and contact failure by wrong insertion of FFC	<p>When replacing heads, replace the Head FFC ASSY as well. Insert the FFC straight and visually check if they are attached without misalignment.</p> <p>Also the function to check the connection of heads when turning on the printer has been added from following firmware version.</p> <p>JV33-130/160/260 (TS3) : F/W Ver.3.20 or later</p> <p>JV33-130/160/260BS : F/W Ver.3.00 or later</p> <p>CJV33-60/100/130/160 (TPC) : F/W Ver.2.00 or later</p> <p>CJV33-60/100/130/160BS : F/W Ver.2.00 or later</p> <p>If [ERROR 202 DEVICE CONSTRUCTION] occur, it might be a FFC trouble or head/PCB may be damaged.</p> <p>Please refer to the documents below for troubleshooting.</p> <ul style="list-style-type: none"> • CJV30 Maintenance Manual (4.5.1 Handing of FFC) • CJV30 Maintenance Manual (7.2.3 Electrical Troubleshooting)

1

2

3

4

5

6

7

8

7.2.3 Electrical Troubleshooting

	Cause of head/PCB damage	Countermeasures
3	COM noise when turn off the machine and trouble of power sequence.	CJV30: Corrected in Firmware ver.1.0 or later / JV33: Corrected in Firmware ver.1.8 or later. Note: Do not do the followings even if the applied firmware is installed. COM noise can be made and it will cause damage. However, if it is necessary to do the operation mentioned (b), please leave the machine 3 minutes or more before turning on the power. (a) Turning off the main power while "BOOT" is showing. (b) Turning off the main power after "F-ROM" error occurred.
4	Static electricity attack	Modified Head earth plate (M507834_02) to prevent head attack by static electricity charged in media when media jam occurred. However, static electricity may attacks to the slider when the operator touched the slider part to remove the media. Please advice to the customers that discharge by touching the metal part of the machine other than slider before touching the slider or head, and remove the media gently without making static electricity.
5	Replace head associated parts in the condition of electric charge remains.	When replace the head and PCB with electric charge remains in 42V circuit, head and PCB damage may increase. Before replacement, make sure to check if electric charge is not remaining inside of PCB when turning off the power each time. For replacement procedure and precautions, please refer to the attached document "Electric charge checking when replace the head and PCB." Also to shorten the replacement time, resistance has been added to the Main PCB and countermeasure of electric discharge also been added.

1

2

3

4

5

6

7

8

7.2.3 Electrical Troubleshooting

■ Check Flow of the PCB breakage

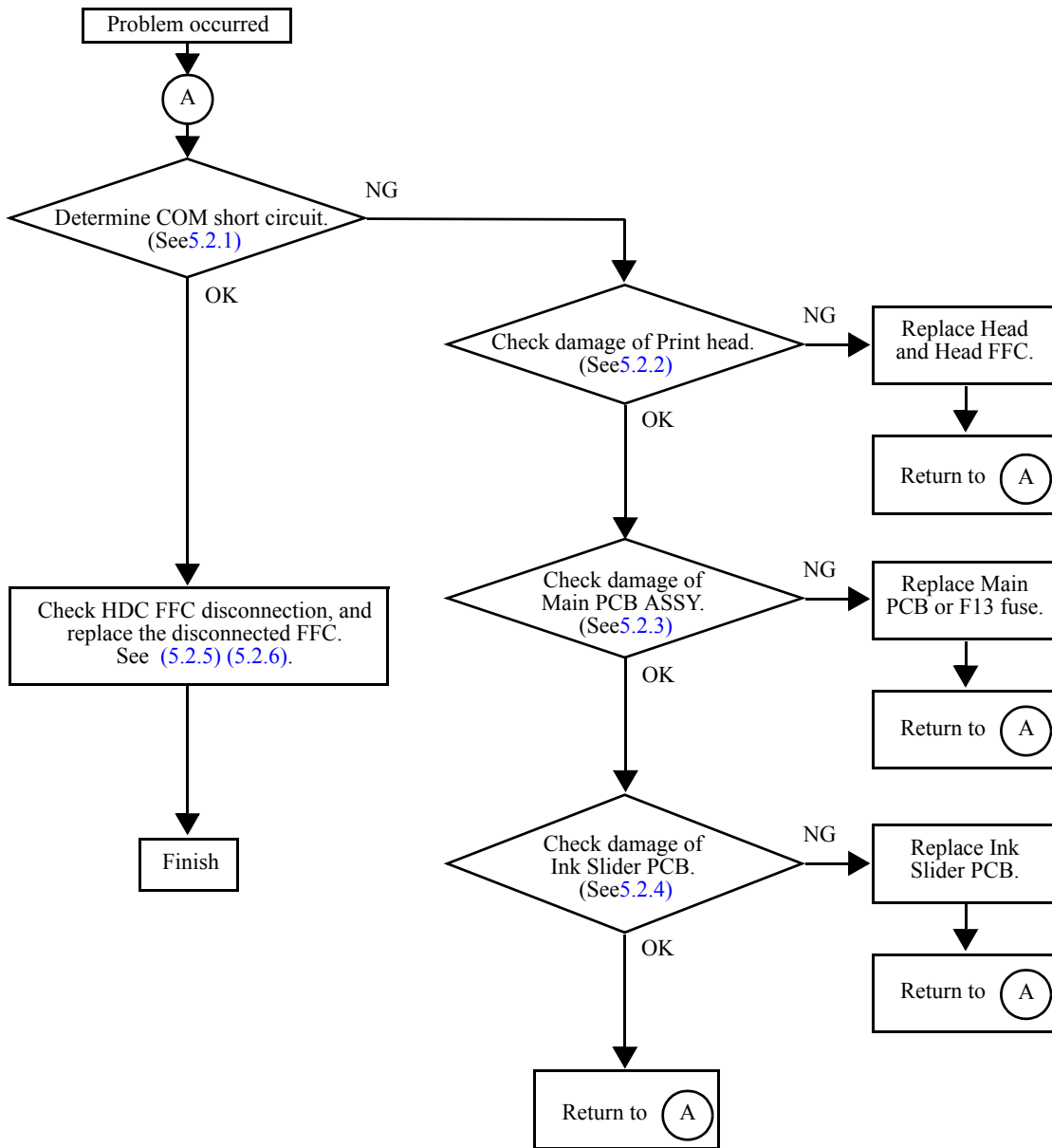

1

2

3

4

5

6

7

8

7.2.4 Y Drive Belt Damage

1.0

■ Outline

The driven pulley tilt over the acceptable range caused by assembly error may slip the Y belt onto the flange and damage the belt. When this problem occurred, replace the belt and adjust the pulley tilt with shim. We also recommend you to check this at the regular maintenance.

■ Tools

- Phillips screwdriver
- Shim: Y-T Spacer L0.4 (M511789)

■ Procedure



Be sure to turn OFF the MAIN power to prevent an unexpected movement of the printer while performing these procedures.

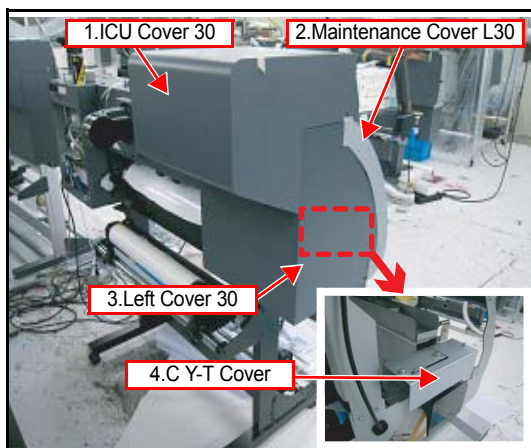

1. Remove the covers in the following order.

1. ICU Cover 30
2. Maintenance Cover L30
3. Left Cover 30
4. C Y-T Cover

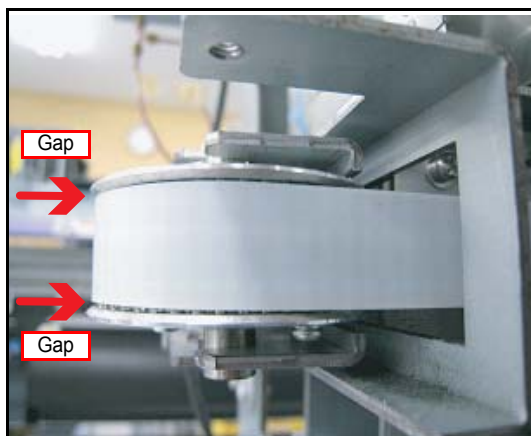

2. Move the head in full width from the right (left) to the left (right) manually. Check the Y-belt condition on the Y-T pulley. When the Y-belt has gap on both sides, or when the belt moves up and down in conjunction with the head, adjustment with the shim is not required.



Cautions for adding the shim

- Make sure to add only one piece of the shim. Adding more than two pieces may deform the Y-T pulley BKT ASSY.
- Additional adjustment is not required because the shim is made to fulfill a proper alignment with one. The alignment cannot be measured on site. Follow the instructions below.

1

2

3

4

5

6

7

8

7.2.4 Y Drive Belt Damage

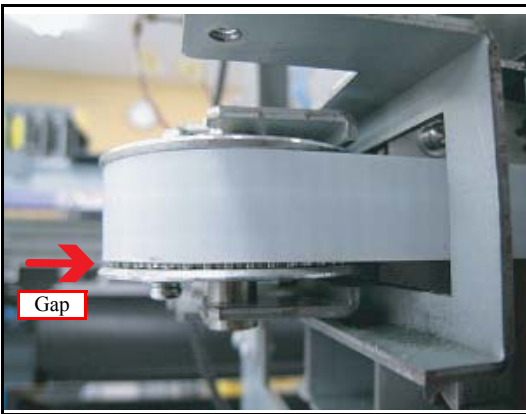

3. In case that the Y belt is raised on the Y-T pulley.
Loosen the belt tension, loosen the all screws fixing the Y-T pulley BKT ASSY to the Y-bar, then attach the shim to the upper side.



- Attach the shim to touch both the rear and the front side of the Y bar.
- Attach the adhesive face of the shim to the upper side of the Y-T pulley BKT ASSY.
- Do not attach the shim to the Y-bar side.

1

2

3

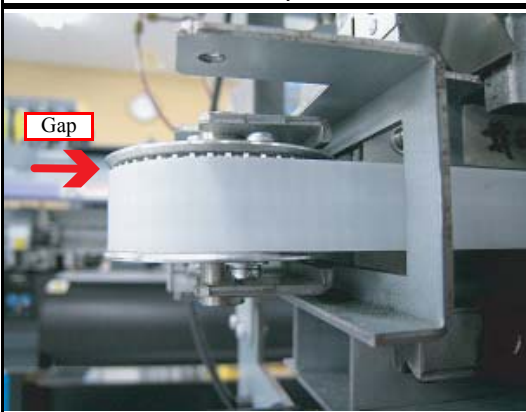
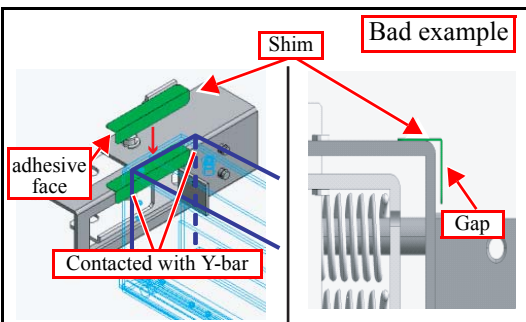

4. In case that the Y belt is lowered on the Y-T pulley.
Loosen the belt tension, loosen the all screws fixing the Y-T pulley BKT ASSY to the Y-bar, then attach the shim to the lower side.



- Attach the shim to touch both the rear and the front side of the Y bar.
- Attach the adhesive face of the shim to the lower side of the Y-T pulley BKT ASSY.
- Do not attach the shim to the Y-bar side.

4

5

6

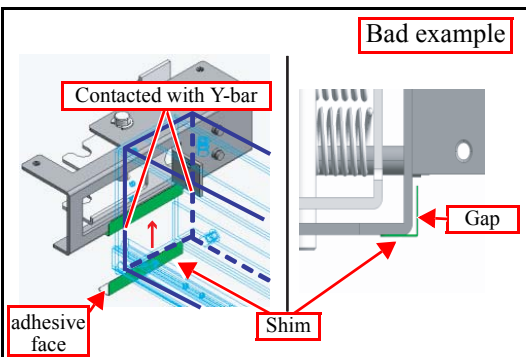

7

8

5. Press the Y-T pulley BKT ASSY to the Y-bar and fix the screws.
Readjust the belt tension and attach the removed covers.

7.2.5 Heater temperature does not going up

■ Outline

If the heater temperature could not rise up to setting value or [BREAK] displayed, it is possibility of power supply PCB burnout or fuse blowout. Blowout also can be checked by measuring resistance value at the both ends of fuse with tester when it has difficulty with visually checking.

Heater disconnection or faulty connection, disconnection or faulty connection of control signal and Main PCB damage also think as a possibility why the heater temperature cannot go up.

Follow the directions below to find out the faulty points and deal with proper countermeasure.

■ Working procedure (Test)

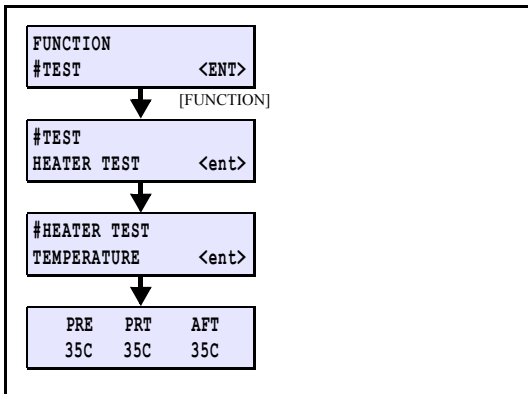

1. Turing off the sub and main power switches in order and wait a while to reboot the machine.
2. Operate [# TEST TEST]-[HEATER TEST] to check if media heater is working normally.
3. When [BREAK] displayed, follow the directions below to find out trouble point.

■ Working procedure (Checking of Power Supply PCB)



After turning off the sub and main power switches in order, unplug the power code. Make sure to restart operation after checking that no electric charge remains in the PCB. It is very dangerous if sleep mode functions mistakenly during the operation. Moreover, the PCB may be damaged in case electric charge still remains inside. Also there is a possibility of electric shock because of high power voltage applied the high-pressure part of the power supply PCB assy. Take care to avoid contact with it.

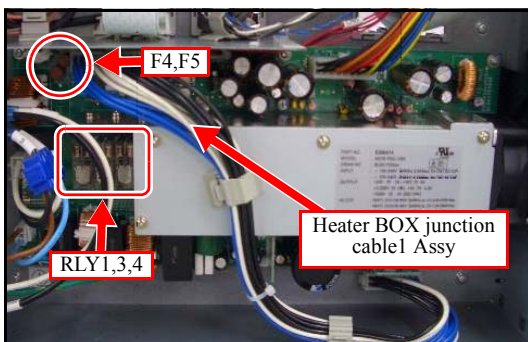

1. Remove the Power Box Cover.
2. Check if no electric charge is remaining in the PCB. Refer to the "4.5.2 Electric charge checking when replace the head/PCB"

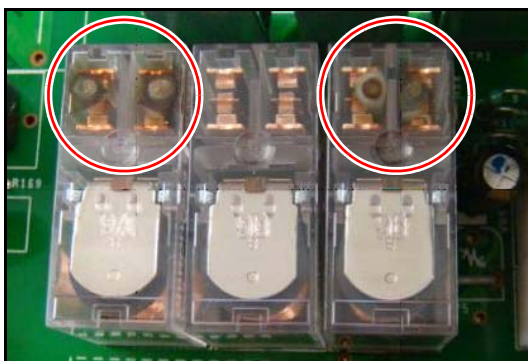

3. Check RLY1, 3 and 4 of the power supply PCB. If PCB brounout as shown in the picture on the left, replace the PCB.

7.2.5 Heater temperature does not going up



4. Check F4 and F5 of the power supply PCB.

If PCB brounout as shown in the poicture on the left, replace the PCB.

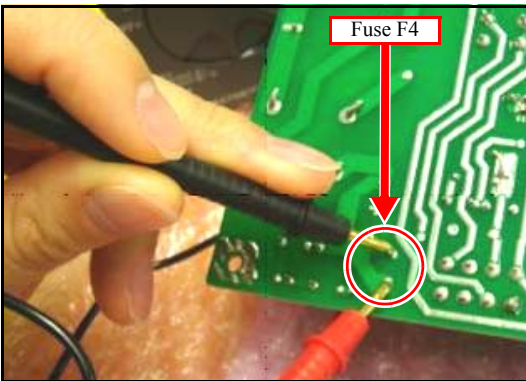

5. If you cannot operate visual checking, measure the resistance of F4 from the back side of PCB as shown in the picture on the left. Make sure to have resistance value is 5Ω or less. Replace the PCB if resistance value is more than 5Ω .

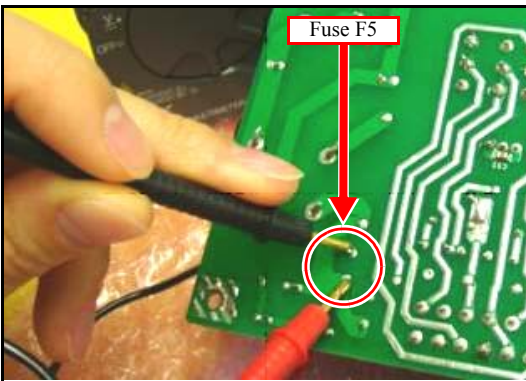

6. Check F5 in a same way as F4 to check the resistance value is 5Ω or less. Relace the PCB if resistance value is more than 5Ω .

1

2

3

4

5

6

7

8

7.2.5 Heater temperature does not going up

Working procedure (check disconnection)

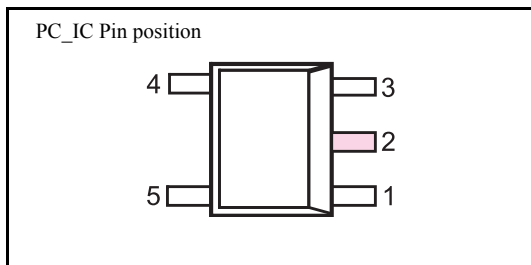
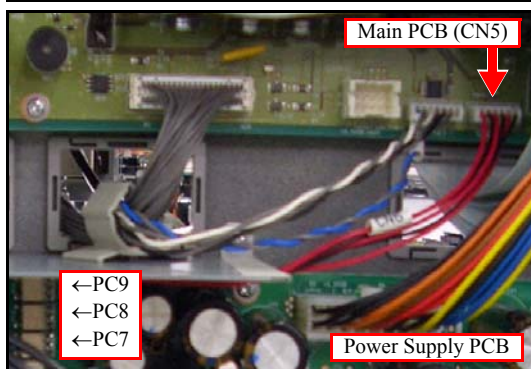
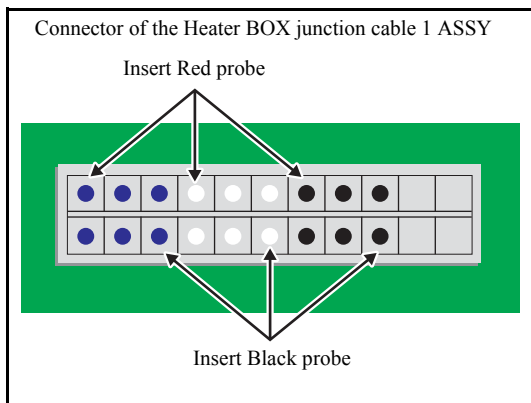

Working procedure (Checking of Main PCB)

1. Check the heater disconnection and faulty connection.

Measure the resistant value of heater BOX junction cable 1 using tester probe. (refer to a picture on the left)

Measured resistance value has no problem if the value is in range as below.

- Rear heater (Blue) : 190-240Ω
- Print heater (White) : 120-160Ω
- After heart (Black) : 110-150Ω

2. Check disconnection and faulty connection of Heater control signal.

Measure the resistance value using PC (Photocoupler) of power supply PCB and CN5 of the main PCB.

Following diagram shows measurement place and value.

Power Supply PCB	Main PCB	Measurement value
PC9-2 pin	CN5-1 pin	5Ω or less
PC8-2 pin	CN5-3 pin	5Ω or less
PC7-2 pin	CN5-3 pin	5Ω or less

1

2

3

4

5

6

7

8

1. If all procedures did not work to solve the problem of temperature rising, it is a possibility of damage in Main PCB. Replace the Main PCB and recheck if temperature enables to read correctly or not.

1

2

3

4

5

6

7

8

Troubleshooting

**7.1
Details on Errors and Malfunctions**

**7.2
Detailed Methods of Coping with
the Malfunctions**

**7.3
Checksheet**

7.3.1 PCB Damage Checksheet

Please fill out this checksheet to search failure sources of head and PCB damage.
We would appreciate your taking time to complete this checksheet

■ Please confirm the machine which has had countermeasure or not.

1. Confirmation for countermeasure of the selected models.	
<input type="checkbox"/>	JV33-130/160, TS3-1600 <input type="checkbox"/> Firmware Version 4.00 or later. <input type="checkbox"/> Main PCB revision label : [<input type="checkbox"/> E104853-*1 Pb/F] or [<input type="checkbox"/> E105997-A Pb/F] (* = A to G) <input type="checkbox"/> Completed countermeasure for HDC FFC disconnection of movable parts.
<input type="checkbox"/>	JV33-130BS/160BS <input type="checkbox"/> Firmware Version 3.00 or later. <input type="checkbox"/> Main PCB revision label : [<input type="checkbox"/> E105454-*1 Pb/F] or [<input type="checkbox"/> E105998-A Pb/F] (* = A to G)
<input type="checkbox"/>	JV33-260, TS3-2600 <input type="checkbox"/> Firmware Version 4.00 or later.
<input type="checkbox"/>	JV33-260BS <input type="checkbox"/> Firmware Version 3.00 or later.
<input type="checkbox"/>	CJV30-60/100/130/160, CJV30-60BS/100BS/130BS/160BS, TPC-1000 <input type="checkbox"/> Firmware Version 2.00 or later.

- Some countermeasure are not completed. Work on uncomplid countermeasure.
- Complid countermeasure. Fill out following A) through E) and attach to the Damage Report.

A> Fill out the machine information,

Damage Date)	Installation Date)	Serial Number	Ink Type	Ink Set
			<input type="checkbox"/> SS21 <input type="checkbox"/> ES3 <input type="checkbox"/> BS <input type="checkbox"/> Other : []	<input type="checkbox"/> 4 color <input type="checkbox"/> 6 +W color <input type="checkbox"/> 6 color <input type="checkbox"/> Other : []

B> Conditions when trouble occurred.

1. Check the conditions below.																													
<input type="checkbox"/>	Unable to turn ON the machine. <input type="checkbox"/> LCD light do not turn on. <input type="checkbox"/> LCD light is on but nothing displayed.																												
<input type="checkbox"/>	Abnormal ink firing. <input type="checkbox"/> Ink firing with particular nozzle line as once. <input type="checkbox"/> No ink firing with particular nozzle line.																												
<input type="checkbox"/>	Error displayed on LCD pannel. Check the Error Code/Message displayed on LCD as below. Also fill in the timing and frequency of error occurrence. Ex. [Everytime occur at test drawing]																												
	<table border="1"> <thead> <tr> <th>Error code/Message</th> <th>Occurred [Timing/Frequency]</th> </tr> </thead> <tbody> <tr> <td><input type="checkbox"/> ERROR 07</td> <td></td> </tr> <tr> <td><input type="checkbox"/> HEAD</td> <td></td> </tr> <tr> <td><input type="checkbox"/> VOLTAGE</td> <td></td> </tr> <tr> <td><input type="checkbox"/> ERROR 50</td> <td></td> </tr> <tr> <td><input type="checkbox"/> MEDIA DETECT</td> <td></td> </tr> <tr> <td><input type="checkbox"/> MEDIA SET POSITION</td> <td></td> </tr> <tr> <td><input type="checkbox"/> ERROR 200 HEAD MEMORY</td> <td></td> </tr> <tr> <td><input type="checkbox"/> ERROR 202 DEVICE CONSTRUCTION</td> <td></td> </tr> <tr> <td><input type="checkbox"/> ERROR 205 47V HEAD VOLTAGE</td> <td></td> </tr> <tr> <td><input type="checkbox"/> ERROR 207</td> <td></td> </tr> <tr> <td><input type="checkbox"/> OVERFLOW</td> <td></td> </tr> <tr> <td><input type="checkbox"/> UNDERFLOW</td> <td></td> </tr> <tr> <td><input type="checkbox"/> SLEW RATE</td> <td></td> </tr> </tbody> </table>	Error code/Message	Occurred [Timing/Frequency]	<input type="checkbox"/> ERROR 07		<input type="checkbox"/> HEAD		<input type="checkbox"/> VOLTAGE		<input type="checkbox"/> ERROR 50		<input type="checkbox"/> MEDIA DETECT		<input type="checkbox"/> MEDIA SET POSITION		<input type="checkbox"/> ERROR 200 HEAD MEMORY		<input type="checkbox"/> ERROR 202 DEVICE CONSTRUCTION		<input type="checkbox"/> ERROR 205 47V HEAD VOLTAGE		<input type="checkbox"/> ERROR 207		<input type="checkbox"/> OVERFLOW		<input type="checkbox"/> UNDERFLOW		<input type="checkbox"/> SLEW RATE	
Error code/Message	Occurred [Timing/Frequency]																												
<input type="checkbox"/> ERROR 07																													
<input type="checkbox"/> HEAD																													
<input type="checkbox"/> VOLTAGE																													
<input type="checkbox"/> ERROR 50																													
<input type="checkbox"/> MEDIA DETECT																													
<input type="checkbox"/> MEDIA SET POSITION																													
<input type="checkbox"/> ERROR 200 HEAD MEMORY																													
<input type="checkbox"/> ERROR 202 DEVICE CONSTRUCTION																													
<input type="checkbox"/> ERROR 205 47V HEAD VOLTAGE																													
<input type="checkbox"/> ERROR 207																													
<input type="checkbox"/> OVERFLOW																													
<input type="checkbox"/> UNDERFLOW																													
<input type="checkbox"/> SLEW RATE																													
<input type="checkbox"/>	Other (describe problem specifically)																												
2. How and in which condition the trouble occurred?																													
<input type="checkbox"/>																													

1
2
3
4
5
6
7
8

7.3.1 PCB Damage Checksheet

C> Conditions before trouble occurred.

1. Please check and fill in the followings if items applied to the condition before trouble occurred.																																							
<input type="checkbox"/>	Operate normally with no problems.																																						
<input type="checkbox"/>	Nozzle dropout/Ink deflection/Abnormal firing start to occur.																																						
<input type="checkbox"/>	Electric power failure or instant blackout occurred.																																						
<input type="checkbox"/>	Sometimes Error and Warning message appeared. Check error code and message listed as below. Also fill in the timing and frequency of error occurrence. Ex. [occurred sometimes while printing]																																						
	<table border="1"> <thead> <tr> <th>Error code/Message</th> <th>Occurred [Timing/Frequency]</th> </tr> </thead> <tbody> <tr> <td><input type="checkbox"/> ERROR 07</td> <td></td> </tr> <tr> <td><input type="checkbox"/> HEAD</td> <td></td> </tr> <tr> <td><input type="checkbox"/> VOLTAGE</td> <td></td> </tr> <tr> <td><input type="checkbox"/> ERROR 50</td> <td></td> </tr> <tr> <td><input type="checkbox"/> MEDIA DETECT</td> <td></td> </tr> <tr> <td><input type="checkbox"/> MEDIA SET POSITION</td> <td></td> </tr> <tr> <td><input type="checkbox"/> ERROR 200 HEAD MEMORY</td> <td></td> </tr> <tr> <td><input type="checkbox"/> ERROR 202 DEVICE CONSTRUCTION</td> <td></td> </tr> <tr> <td><input type="checkbox"/> ERROR 205 47V HEAD VOLTAGE</td> <td></td> </tr> <tr> <td><input type="checkbox"/> ERROR 207</td> <td></td> </tr> <tr> <td><input type="checkbox"/> OVERFLOW</td> <td></td> </tr> <tr> <td><input type="checkbox"/> UNDERFLOW</td> <td></td> </tr> <tr> <td><input type="checkbox"/> SLEW RATE</td> <td></td> </tr> <tr> <td><input type="checkbox"/> ERROR 40 MOTOR ALARM X</td> <td></td> </tr> <tr> <td><input type="checkbox"/> ERROR 41 MOTOR ALARM Y</td> <td></td> </tr> <tr> <td><input type="checkbox"/> ERROR 42 X OVER CURRENT</td> <td></td> </tr> <tr> <td><input type="checkbox"/> ERROR 43 Y OVER CURRENT</td> <td></td> </tr> <tr> <td><input type="checkbox"/></td> <td>Other (describe problem specifically)</td> </tr> </tbody> </table>	Error code/Message	Occurred [Timing/Frequency]	<input type="checkbox"/> ERROR 07		<input type="checkbox"/> HEAD		<input type="checkbox"/> VOLTAGE		<input type="checkbox"/> ERROR 50		<input type="checkbox"/> MEDIA DETECT		<input type="checkbox"/> MEDIA SET POSITION		<input type="checkbox"/> ERROR 200 HEAD MEMORY		<input type="checkbox"/> ERROR 202 DEVICE CONSTRUCTION		<input type="checkbox"/> ERROR 205 47V HEAD VOLTAGE		<input type="checkbox"/> ERROR 207		<input type="checkbox"/> OVERFLOW		<input type="checkbox"/> UNDERFLOW		<input type="checkbox"/> SLEW RATE		<input type="checkbox"/> ERROR 40 MOTOR ALARM X		<input type="checkbox"/> ERROR 41 MOTOR ALARM Y		<input type="checkbox"/> ERROR 42 X OVER CURRENT		<input type="checkbox"/> ERROR 43 Y OVER CURRENT		<input type="checkbox"/>	Other (describe problem specifically)
Error code/Message	Occurred [Timing/Frequency]																																						
<input type="checkbox"/> ERROR 07																																							
<input type="checkbox"/> HEAD																																							
<input type="checkbox"/> VOLTAGE																																							
<input type="checkbox"/> ERROR 50																																							
<input type="checkbox"/> MEDIA DETECT																																							
<input type="checkbox"/> MEDIA SET POSITION																																							
<input type="checkbox"/> ERROR 200 HEAD MEMORY																																							
<input type="checkbox"/> ERROR 202 DEVICE CONSTRUCTION																																							
<input type="checkbox"/> ERROR 205 47V HEAD VOLTAGE																																							
<input type="checkbox"/> ERROR 207																																							
<input type="checkbox"/> OVERFLOW																																							
<input type="checkbox"/> UNDERFLOW																																							
<input type="checkbox"/> SLEW RATE																																							
<input type="checkbox"/> ERROR 40 MOTOR ALARM X																																							
<input type="checkbox"/> ERROR 41 MOTOR ALARM Y																																							
<input type="checkbox"/> ERROR 42 X OVER CURRENT																																							
<input type="checkbox"/> ERROR 43 Y OVER CURRENT																																							
<input type="checkbox"/>	Other (describe problem specifically)																																						
2. Please write conditions or phenomenon in mind before trouble occurred.																																							
<input type="checkbox"/>																																							

D> Please fill in replaced parts and replacement order.

	Replacement Parts	Order	Solved	Unsolved	Condition changed [describe conditions below]
<input type="checkbox"/>	Head	[]	<input type="checkbox"/>	<input type="checkbox"/>	
<input type="checkbox"/>	Head FFC ASSY	[]	<input type="checkbox"/>	<input type="checkbox"/>	
<input type="checkbox"/>	HDC FFC ASSY	[]	<input type="checkbox"/>	<input type="checkbox"/>	
<input type="checkbox"/>	PCB	[]	<input type="checkbox"/>	<input type="checkbox"/>	
	<input type="checkbox"/> Main PCB				
	PCB No. Before replacement []				After replacement []
	<input type="checkbox"/> Slider PCB	[]	<input type="checkbox"/>	<input type="checkbox"/>	
	<input type="checkbox"/> Power supply PCB	[]	<input type="checkbox"/>	<input type="checkbox"/>	
<input type="checkbox"/>	Fuse of Main PCB	[]	<input type="checkbox"/>	<input type="checkbox"/>	
<input type="checkbox"/>	Others Parts				
	[]	[]	<input type="checkbox"/>	<input type="checkbox"/>	
	[]	[]	<input type="checkbox"/>	<input type="checkbox"/>	
	[]	[]	<input type="checkbox"/>	<input type="checkbox"/>	
	[]	[]	<input type="checkbox"/>	<input type="checkbox"/>	

E> Please write down below any advice or comment.

1

2

3

4

5

6

7

8

1

2

3

4

5

6

7

8

Operation Flow

8.1 Basic Operation	8.2 Print Mode	8.3 Cut Mode
8.4 Common Setting	8.5 Service Mode	

8.1.1 Start

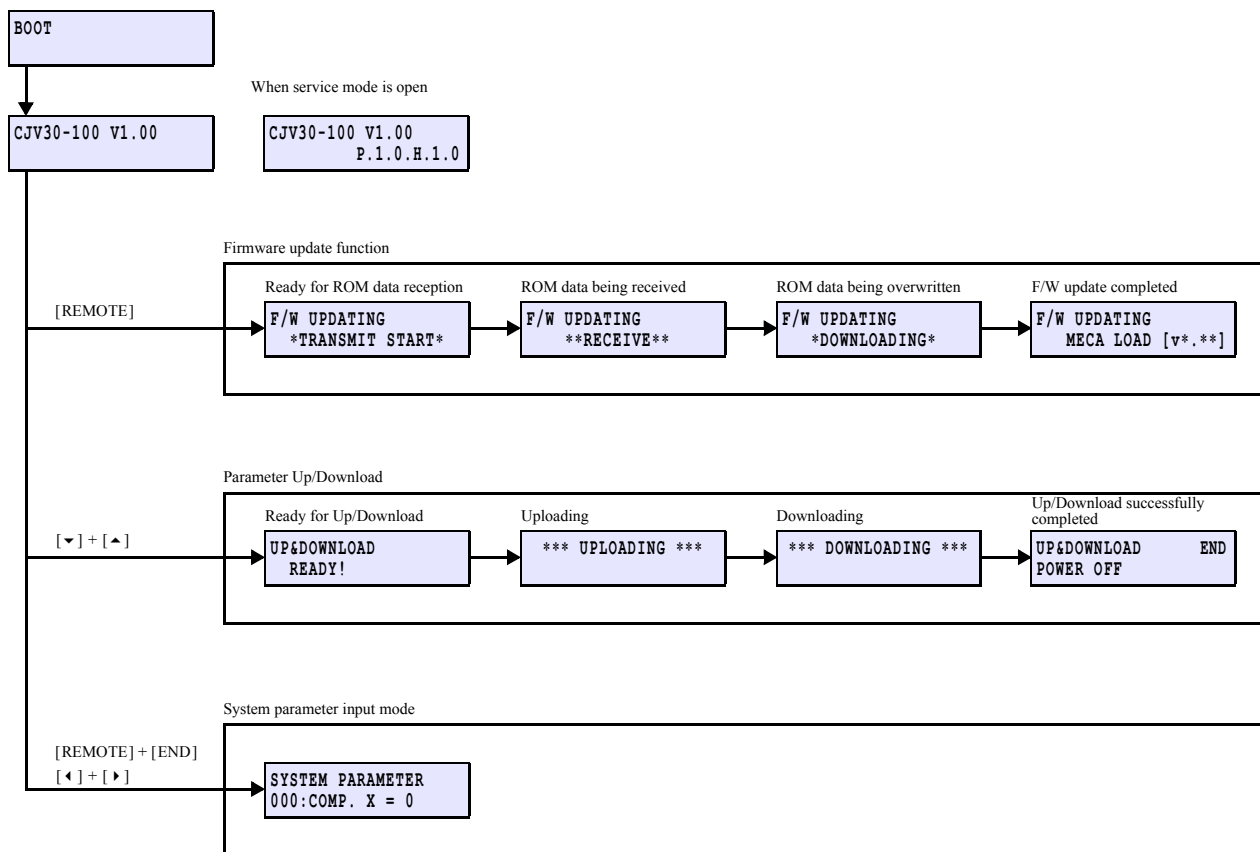

1

2

3

4

5

6

7

8

8.1.2 Initial Filling

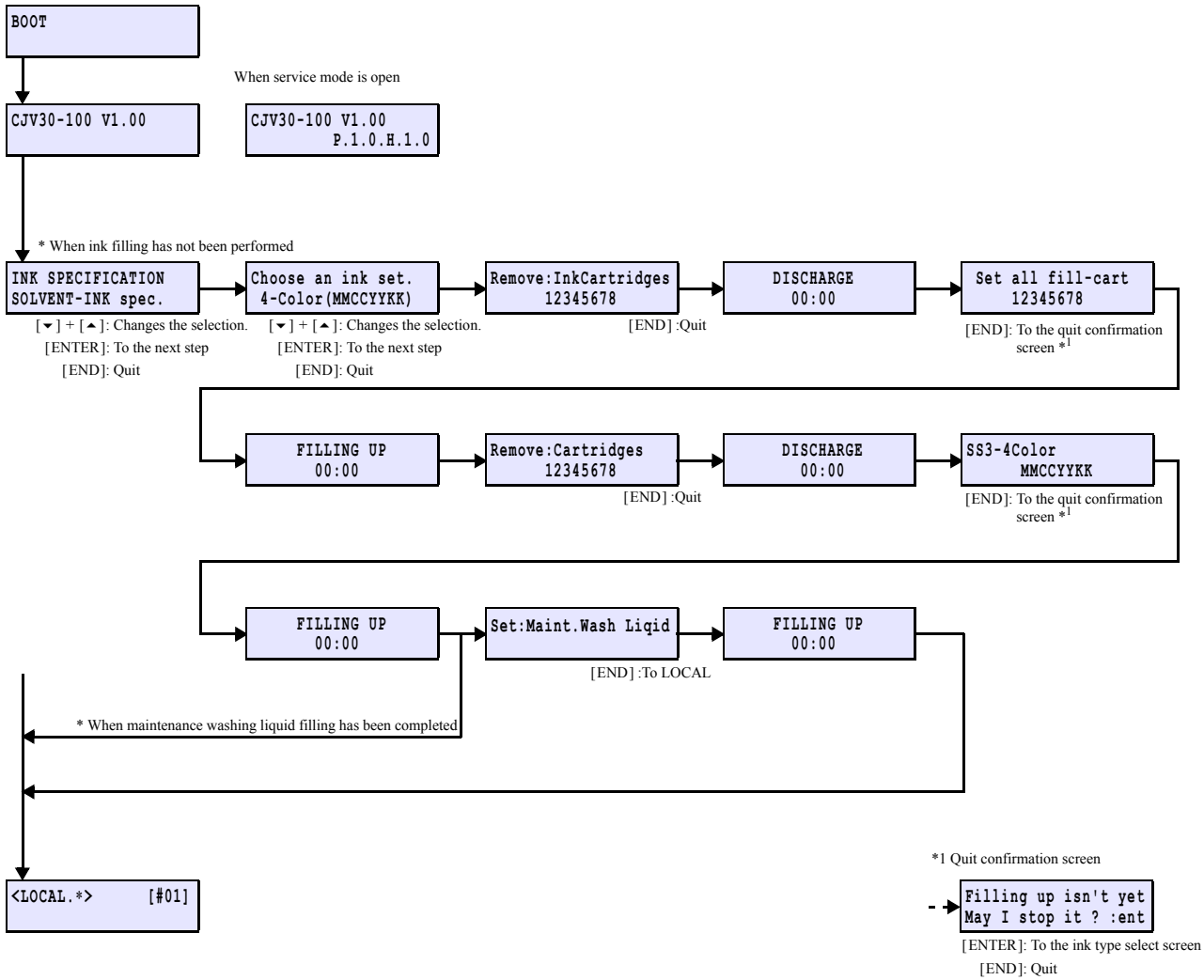

8.1.3 Media Detection

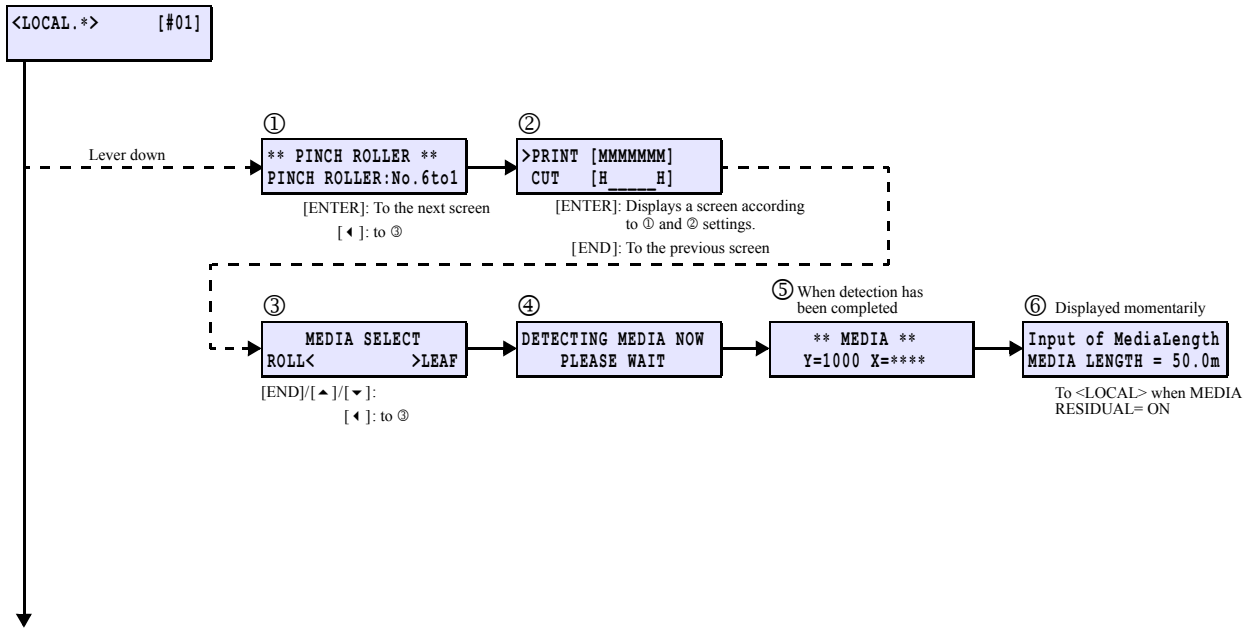

1

2

3

4

5

6

7

8

1

2

3

4

5

6

7

8

Operation Flow

8.1 Basic Operation	8.2 Print Mode	8.3 Cut Mode
8.4 Common Setting	8.5 Service Mode	

8.2.1 LOCAL / REMOTE

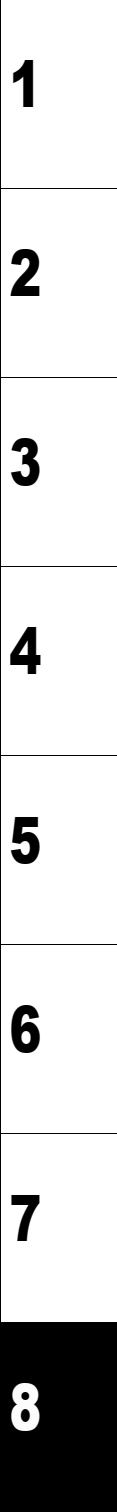
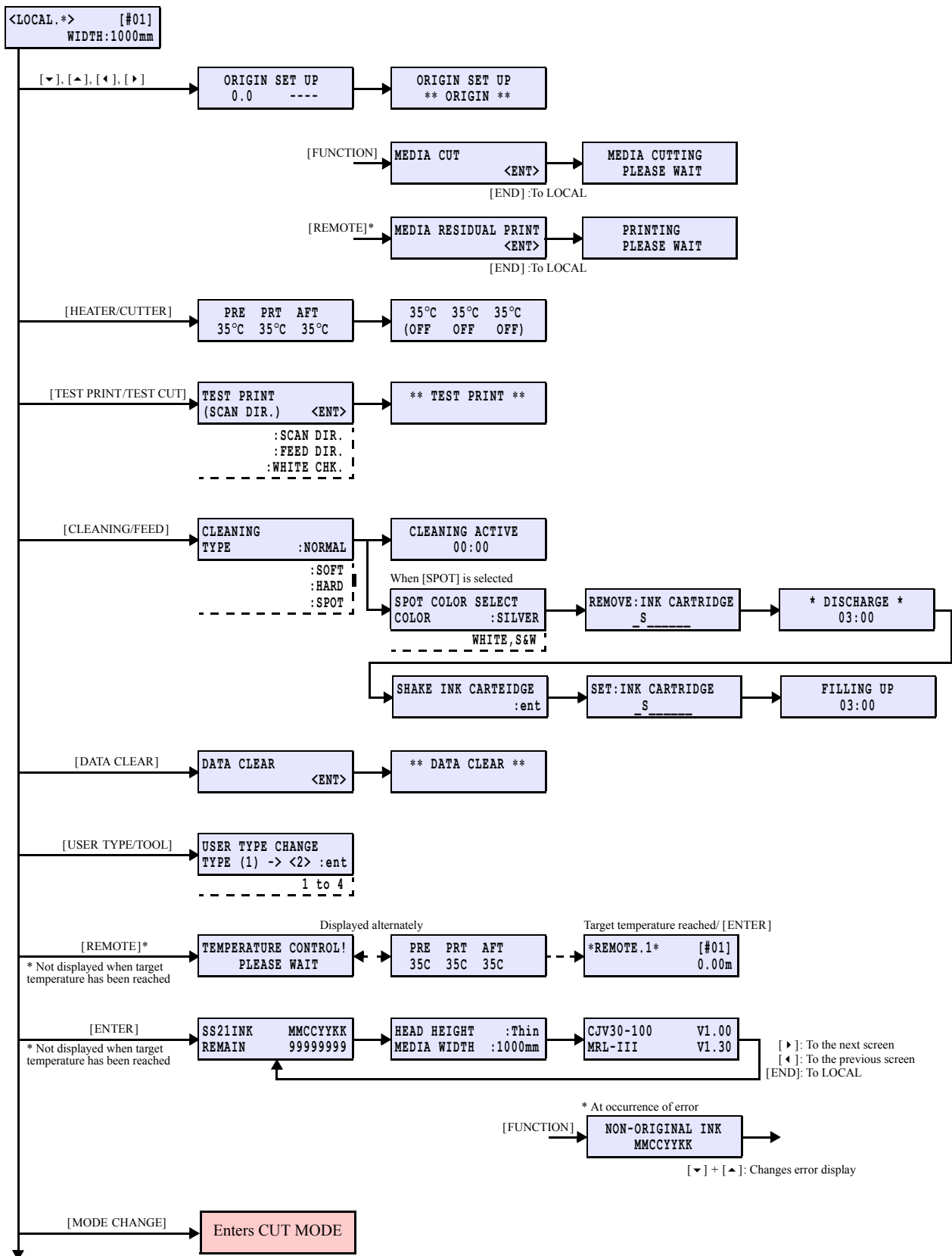

8.2.1 LOCAL / REMOTE

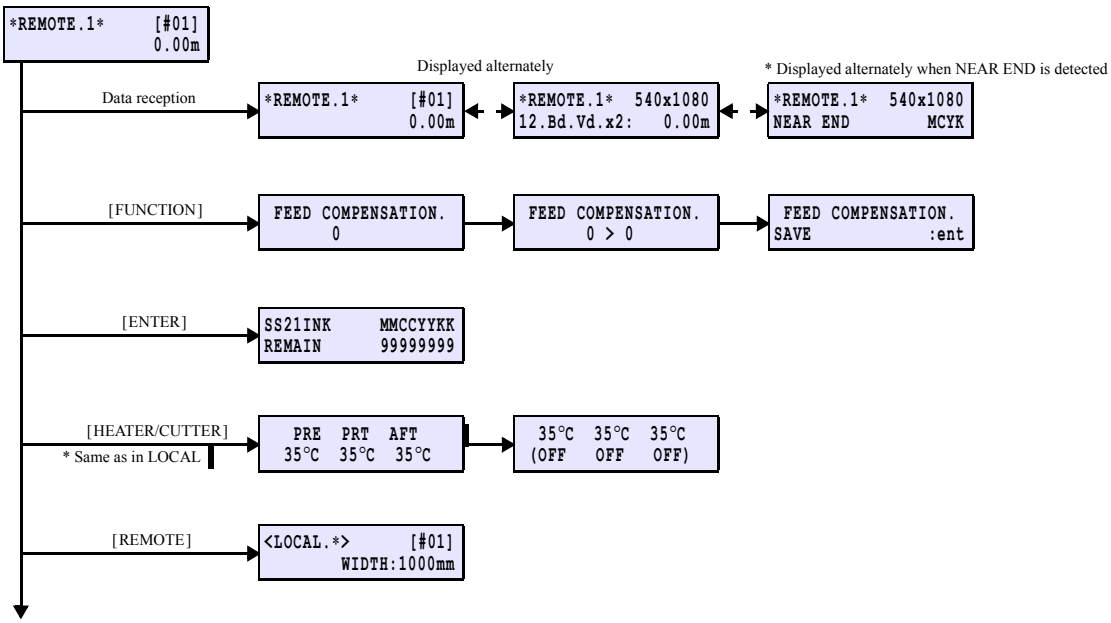

- 1
- 2
- 3
- 4
- 5
- 6
- 7
- 8

8.2.2 SETUP

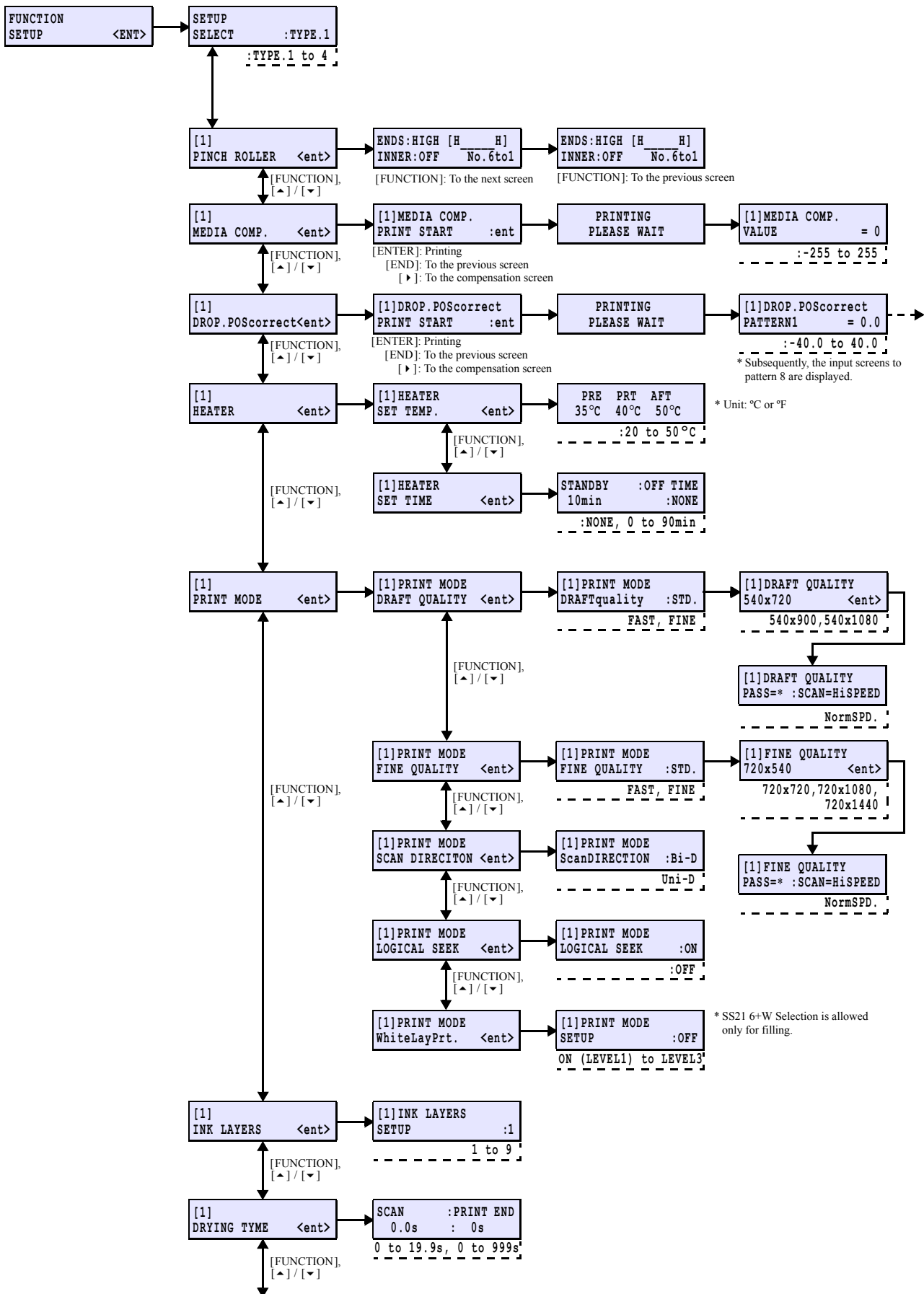

- 1
- 2
- 3
- 4
- 5
- 6
- 7
- 8

8.2.2 SETUP

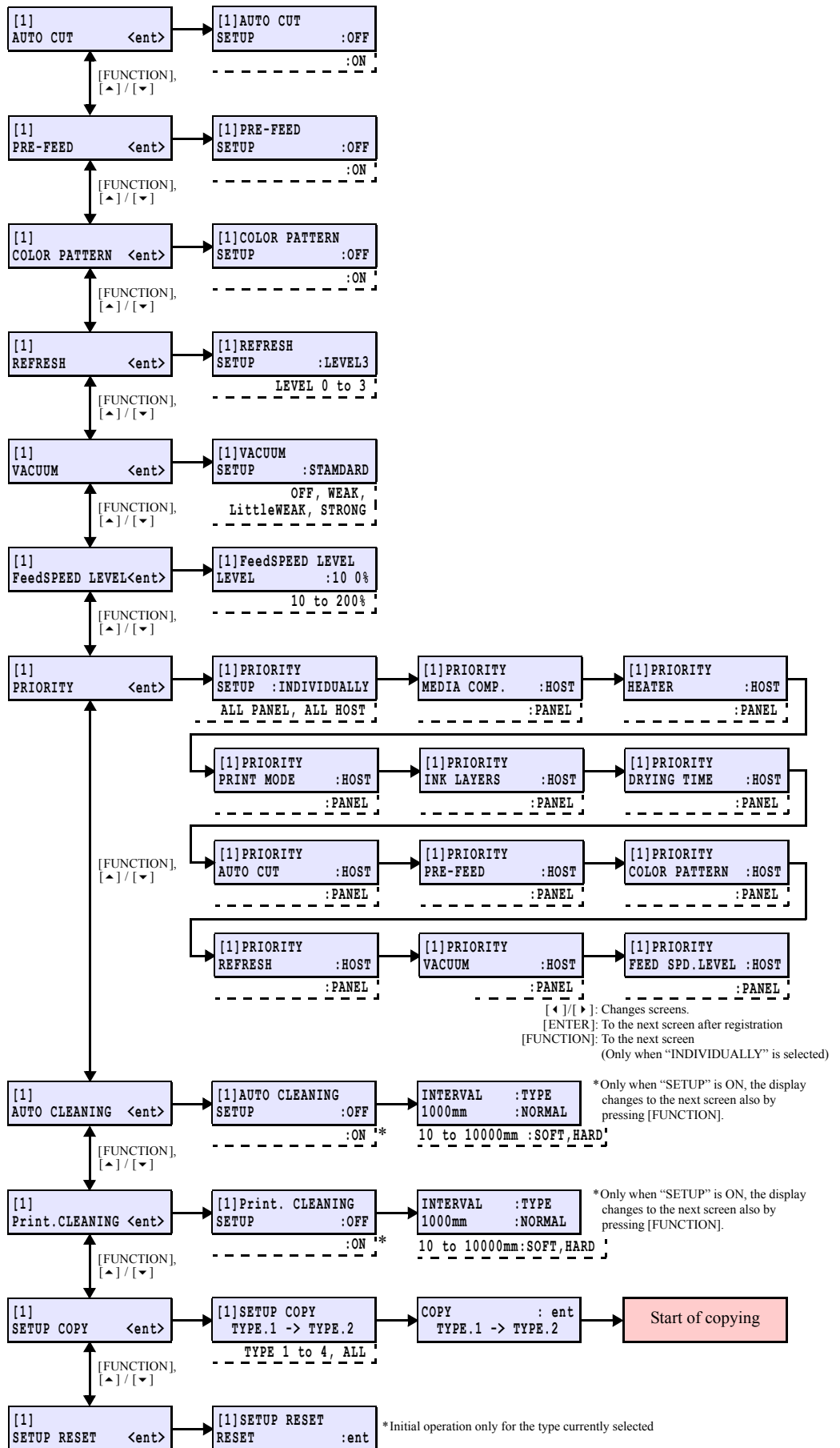

1

2

3

4

5

6

7

8

8.2.2 SETUP

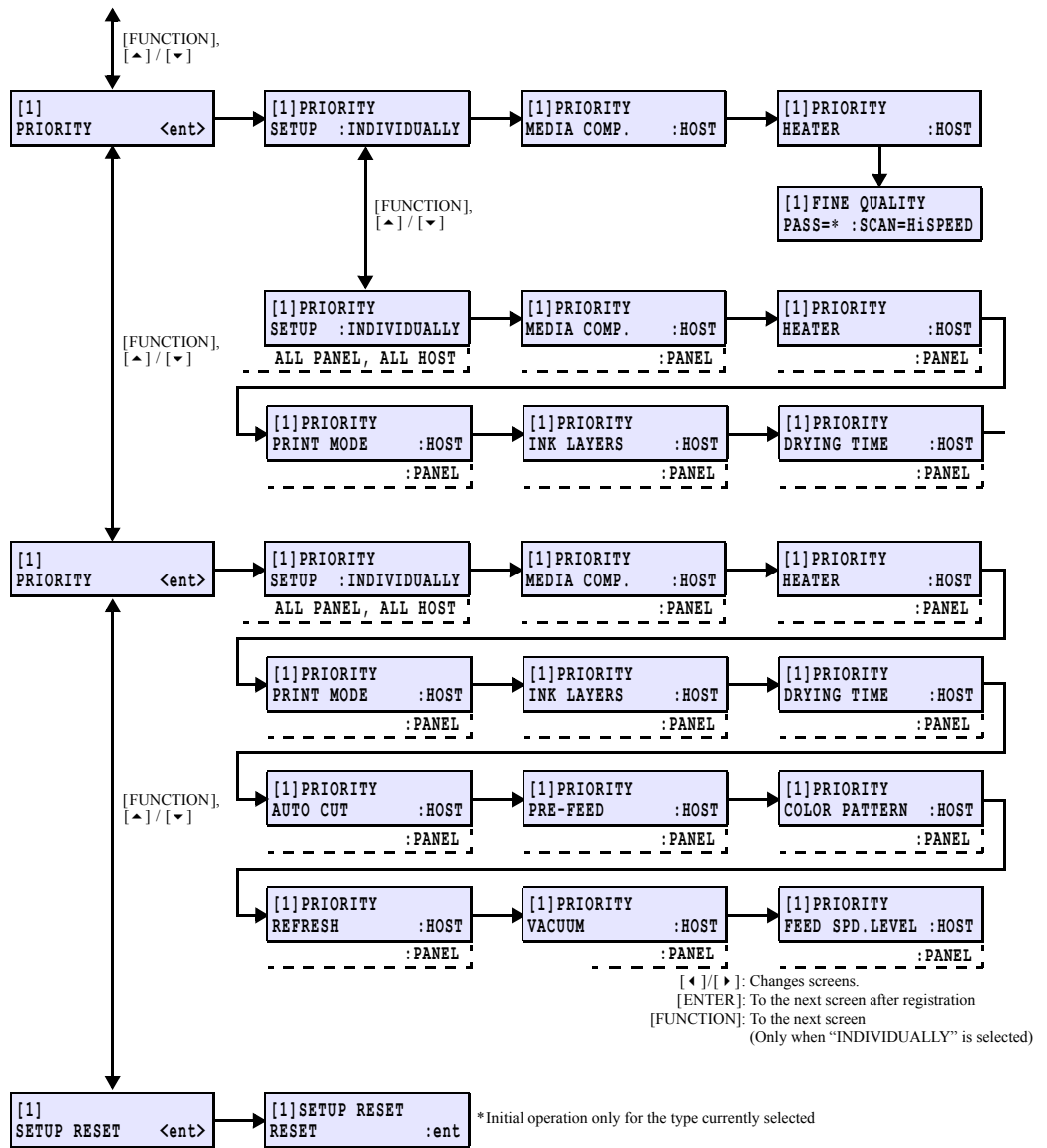

1

2

3

4

5

6

7

8

8.2.3 MAINTENANCE

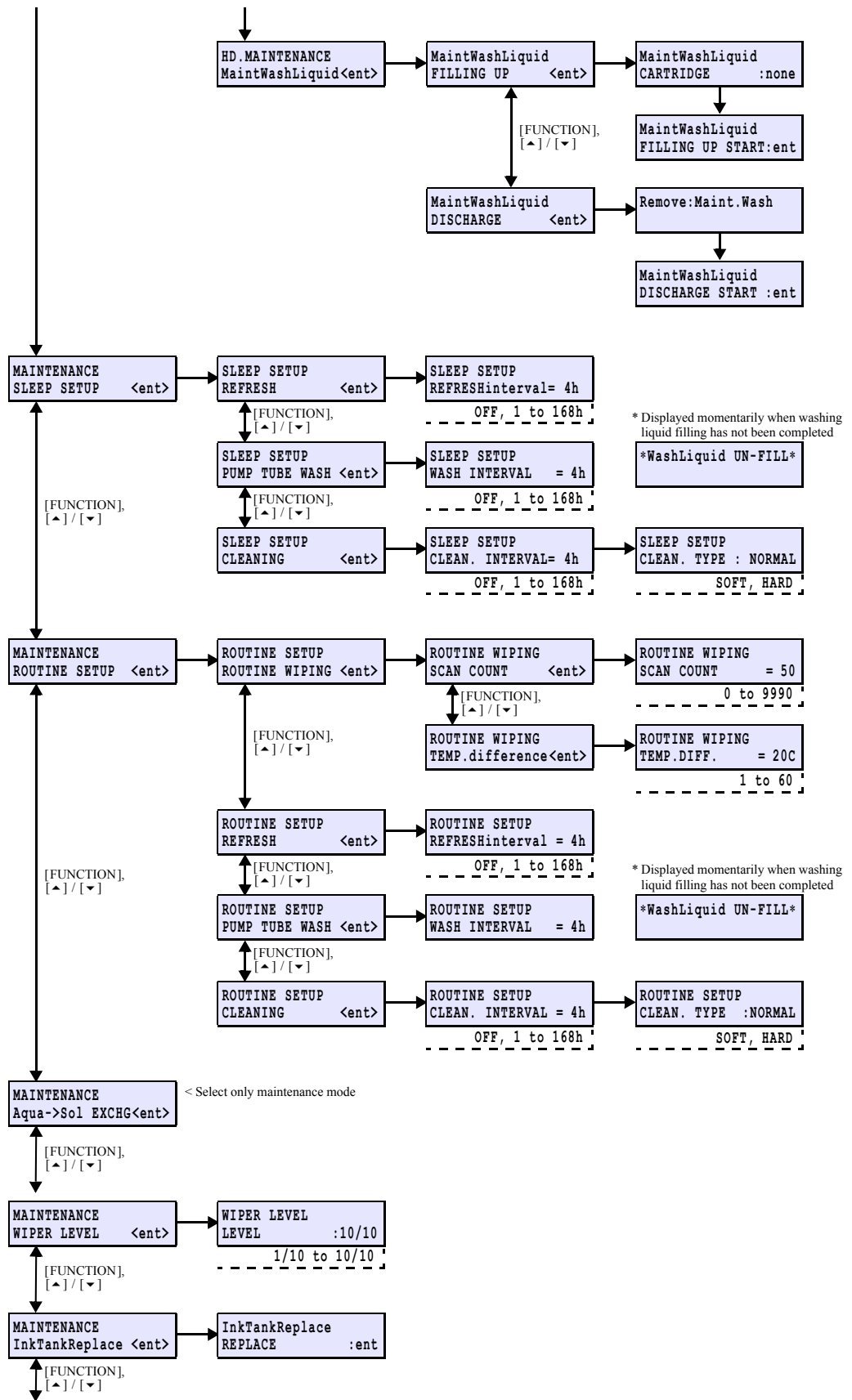

- 1
- 2
- 3
- 4
- 5
- 6
- 7
- 8

8.2.3 MAINTENANCE

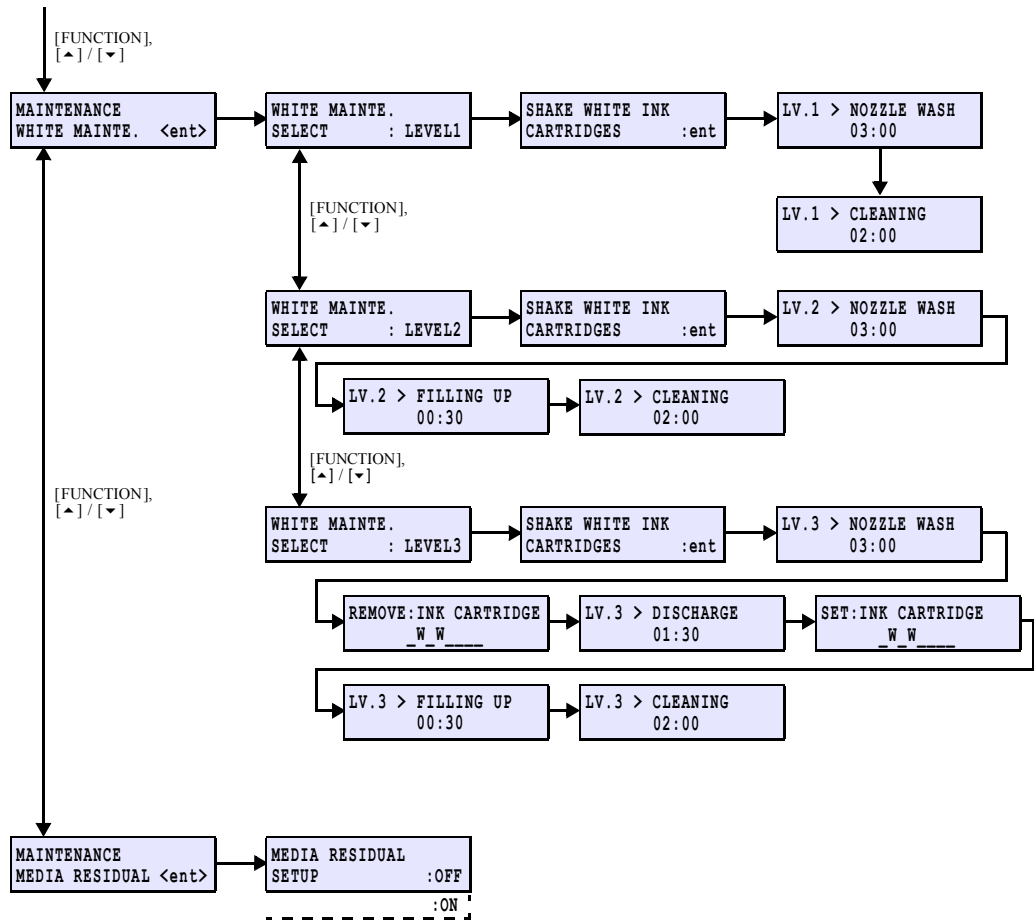

1

2

3

4

5

6

7

8

8.2.4 MACHINE SETUP

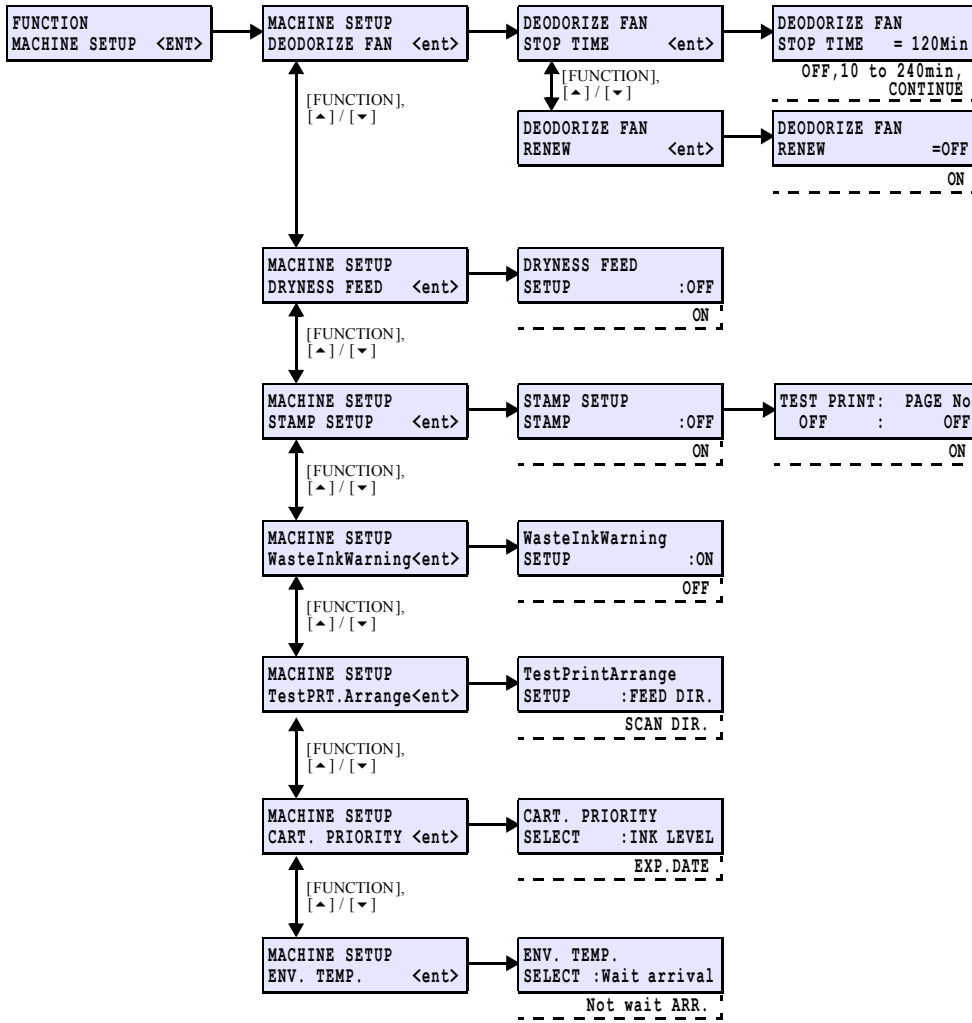

*Displayed by press of [FUNCTION] with Stamp set to "ON" only in maintenance OPEN mode

1

2

3

4

5

6

7

8

1

2

3

4

5

6

7

8

Operation Flow

8.1 Basic Operation	8.2 Print Mode	8.3 Cut Mode
8.4 Common Setting	8.5 Service Mode	

8.3.1 LOCAL / REMOTE

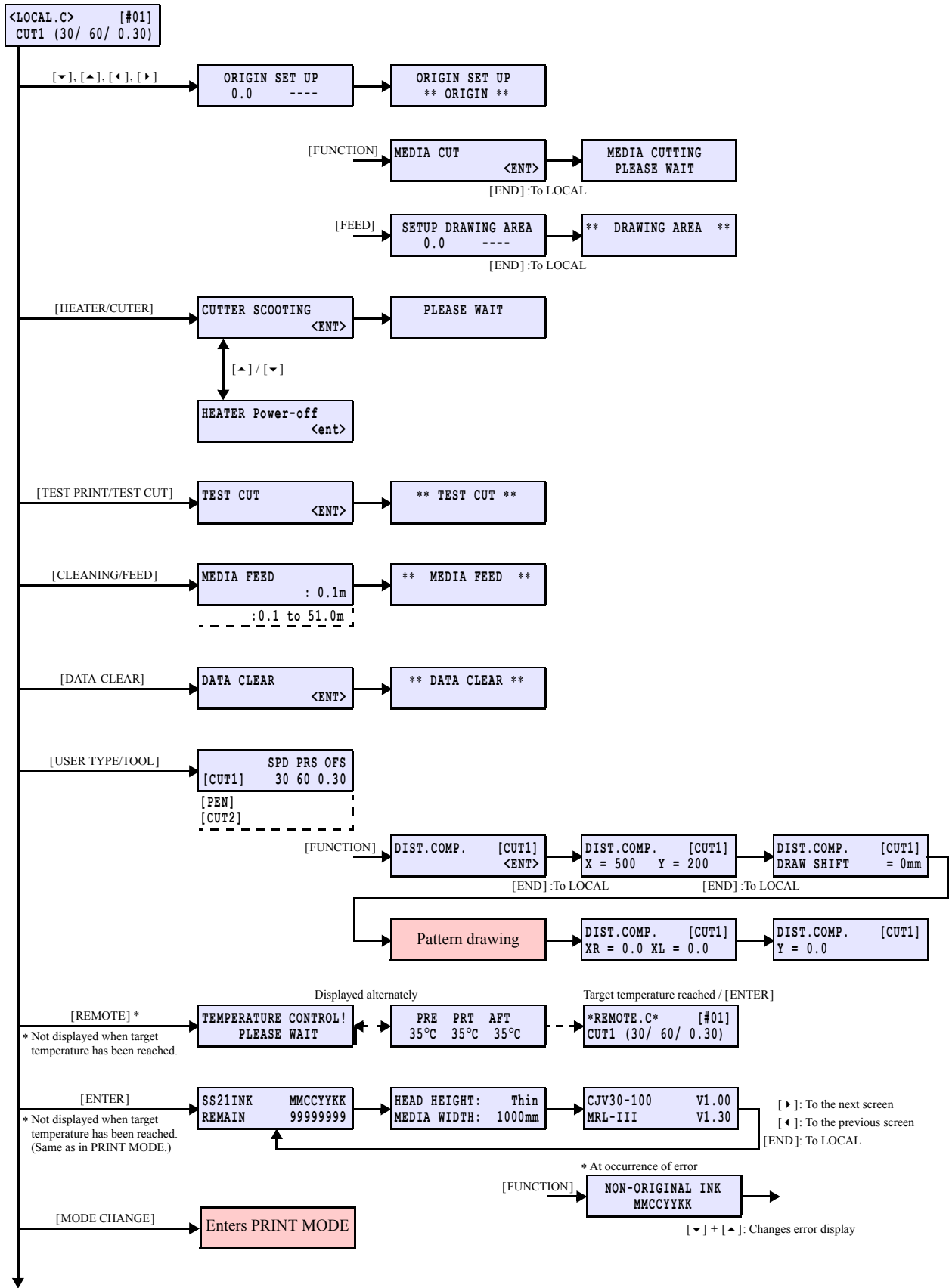

1

2

3

4

5

6

7

8

8.3.1 LOCAL / REMOTE

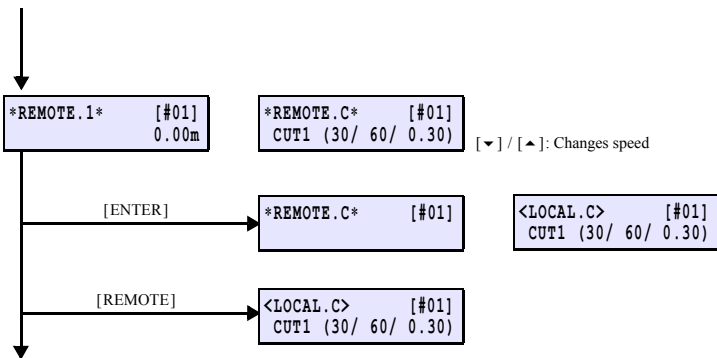

1

2

3

4

5

6

7

8

8.3.2 SETUP

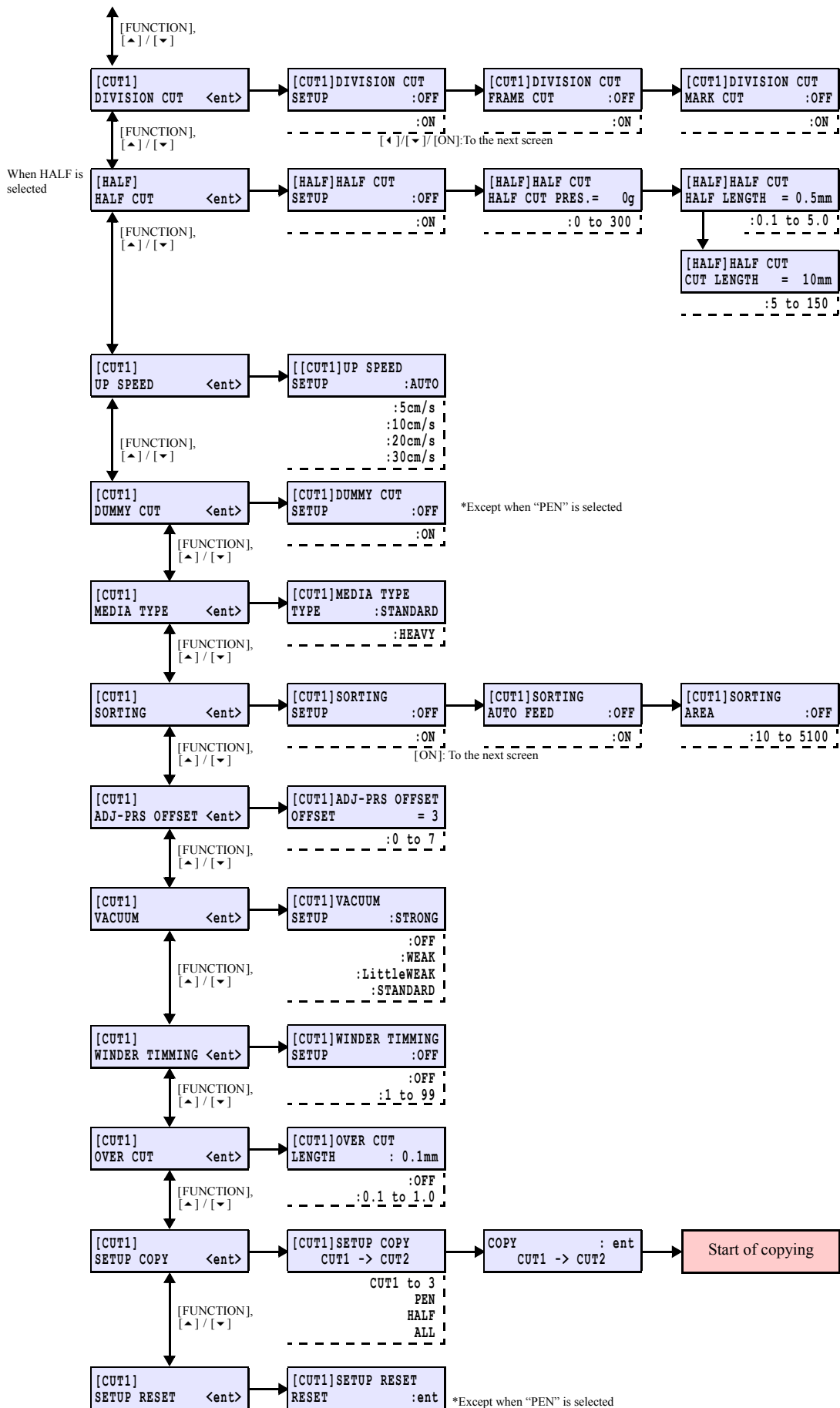

1

2

3

4

5

6

7

8

8.3.3 MAINTENANCE / No. COPIES

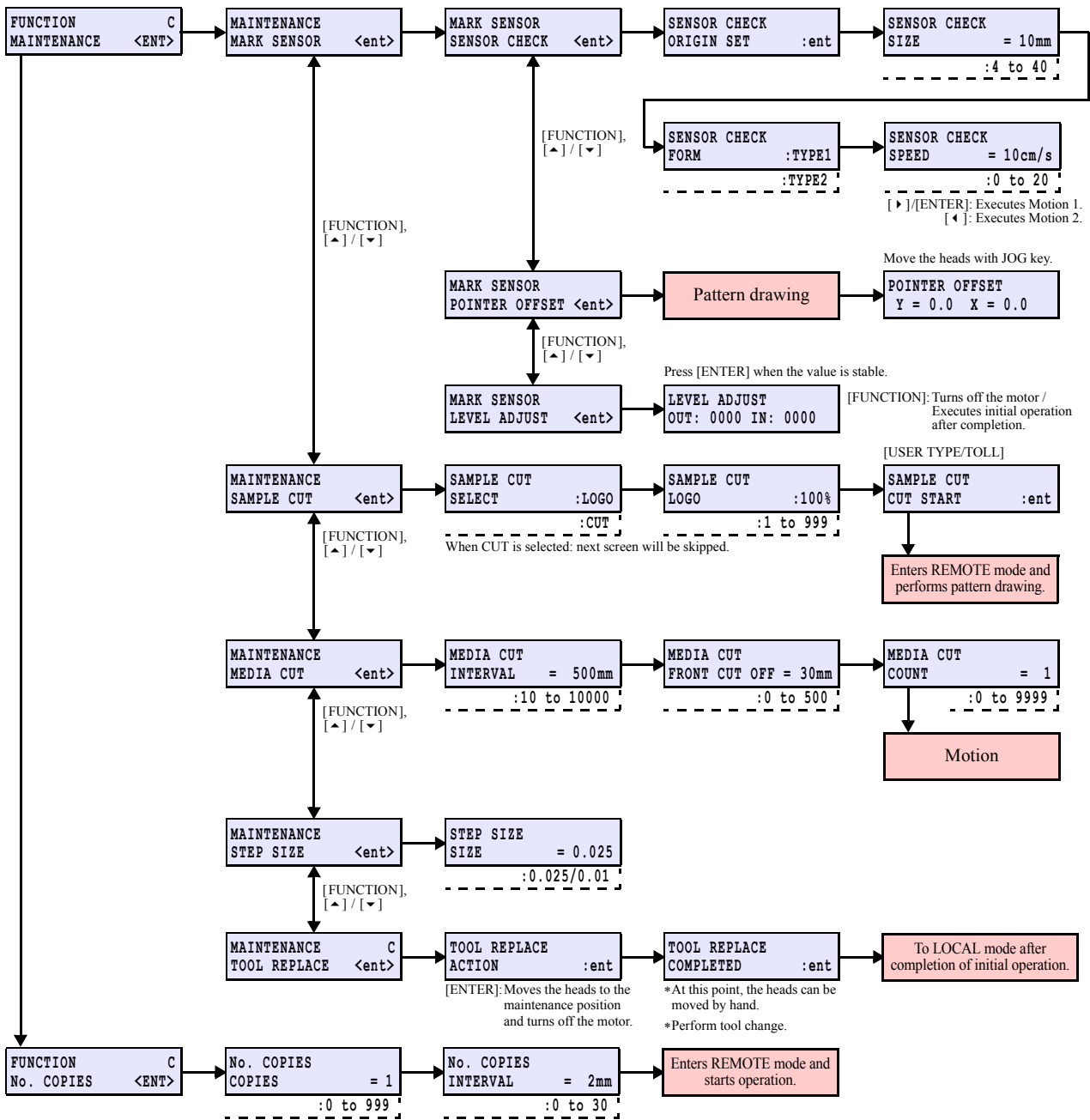

- 1
- 2
- 3
- 4
- 5
- 6
- 7
- 8

1

2

3

4

5

6

7

8

Operation Flow

8.1 Basic Operation	8.2 Print Mode	8.3 Cut Mode
8.4 Common Setting	8.5 Service Mode	

8.4.1 COMMON SETUP

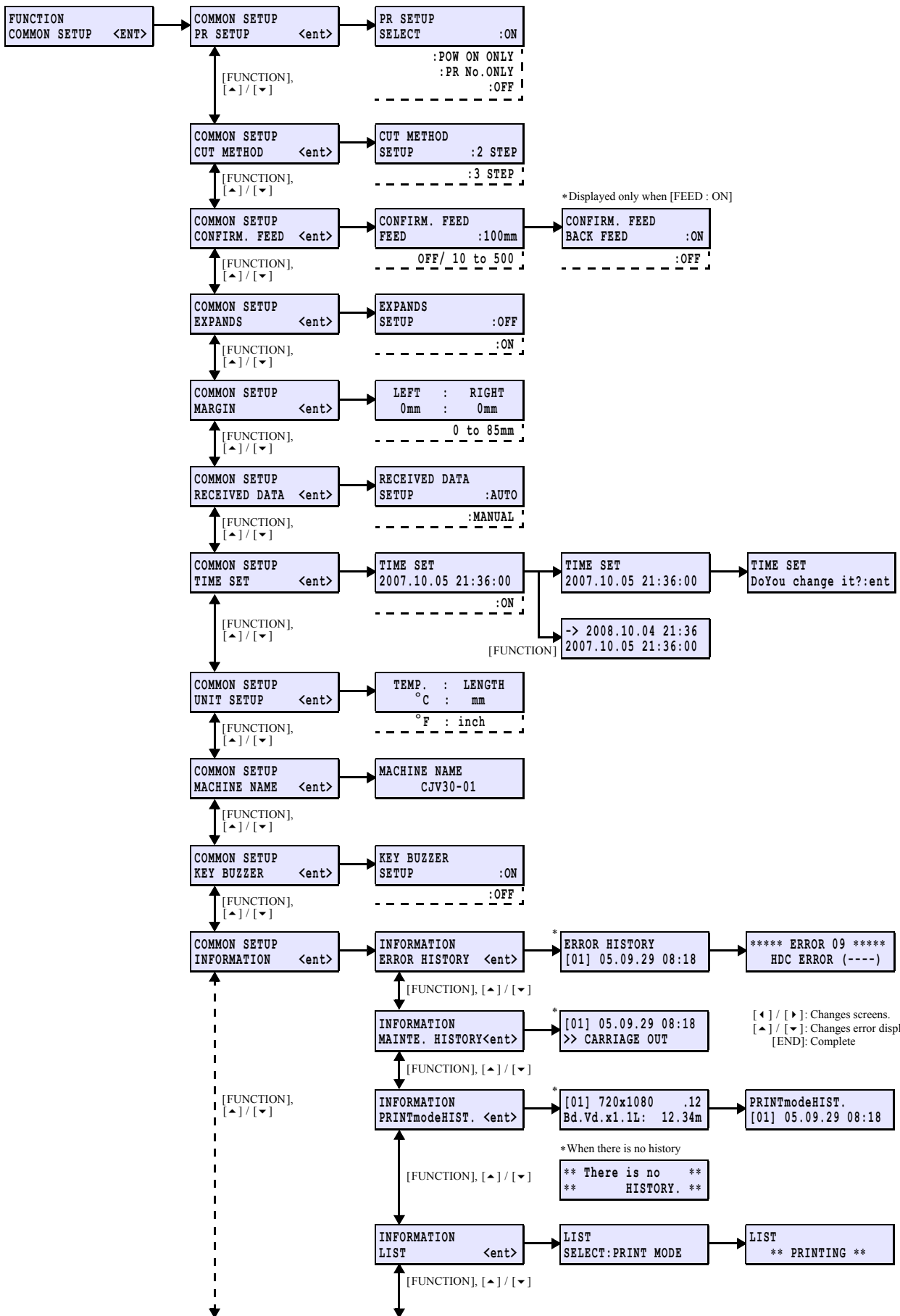

- 1
- 2
- 3
- 4
- 5
- 6
- 7
- 8

8.4.1 COMMON SETUP

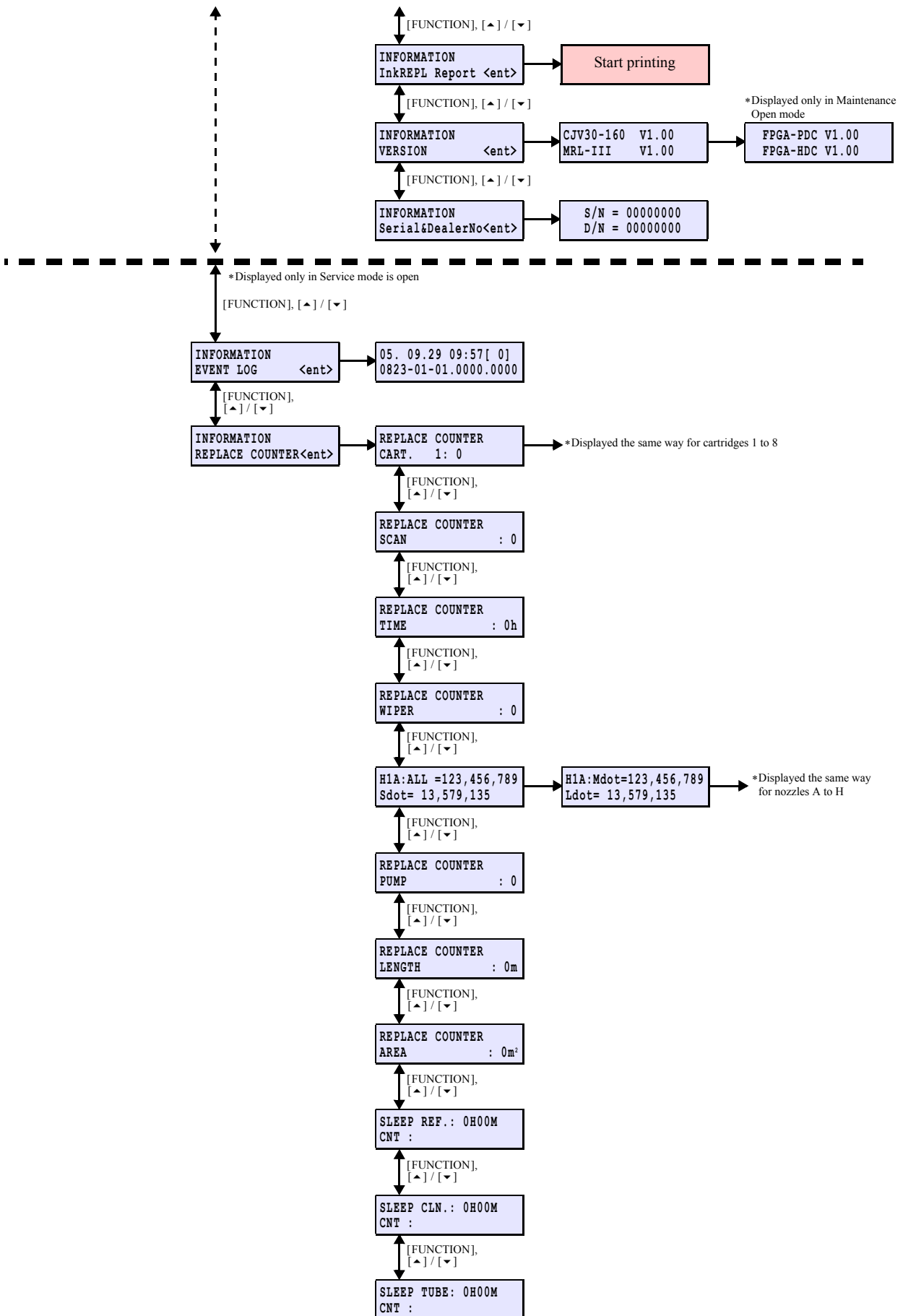

- 1
- 2
- 3
- 4
- 5
- 6
- 7
- 8

1

2

3

4

5

6

7

8

Operation Flow

8.1 Basic Operation	8.2 Print Mode	8.3 Cut Mode
8.4 Common Setting	8.5 Service Mode	

8.5.1 #ADJUST

[▲]/[▼]: Modifies the compensation value.
 [ENTER]: Finalizes (To the next compensation screen)

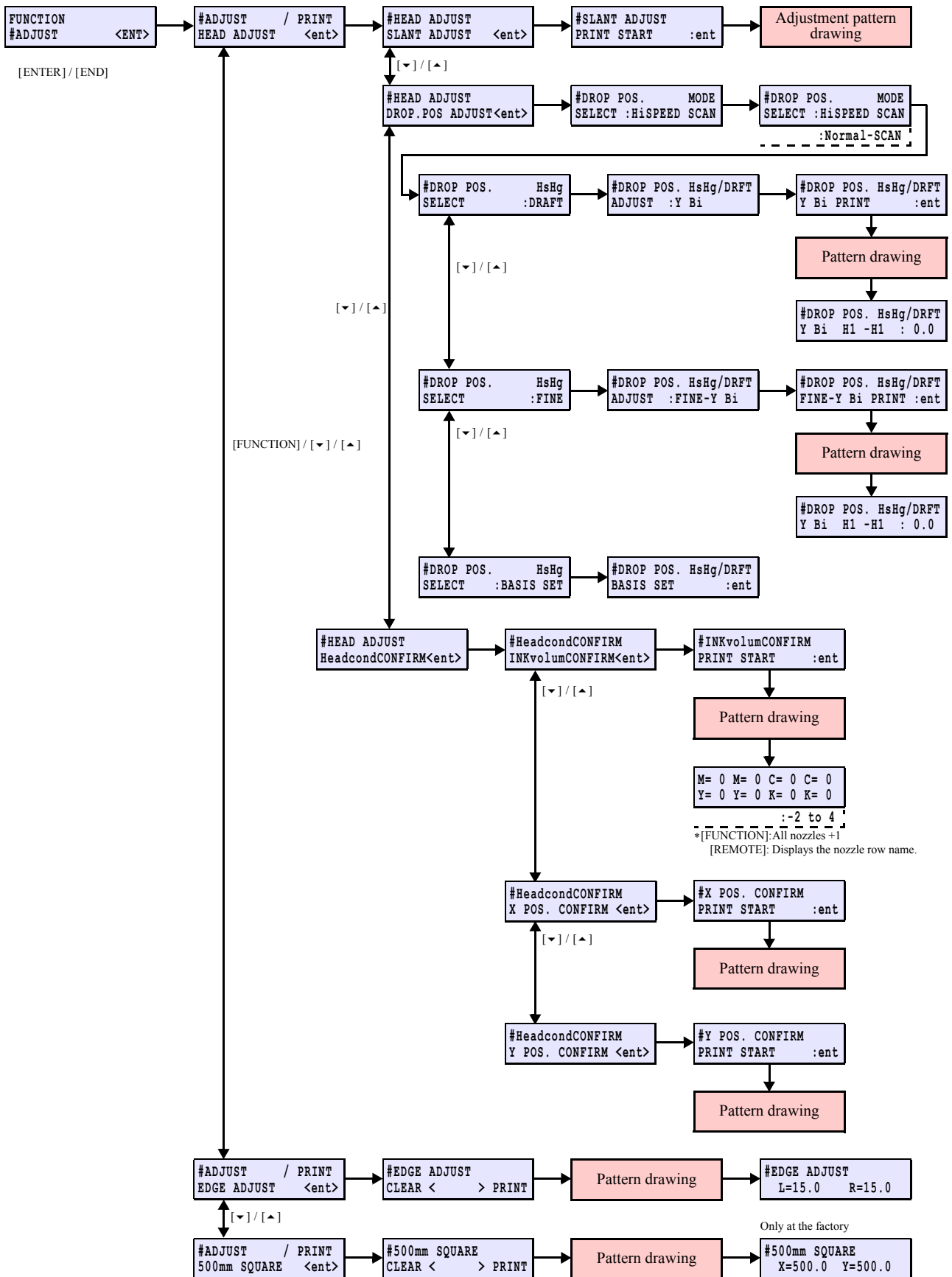

- 1
- 2
- 3
- 4
- 5
- 6
- 7
- 8

8.5.1 #ADJUST

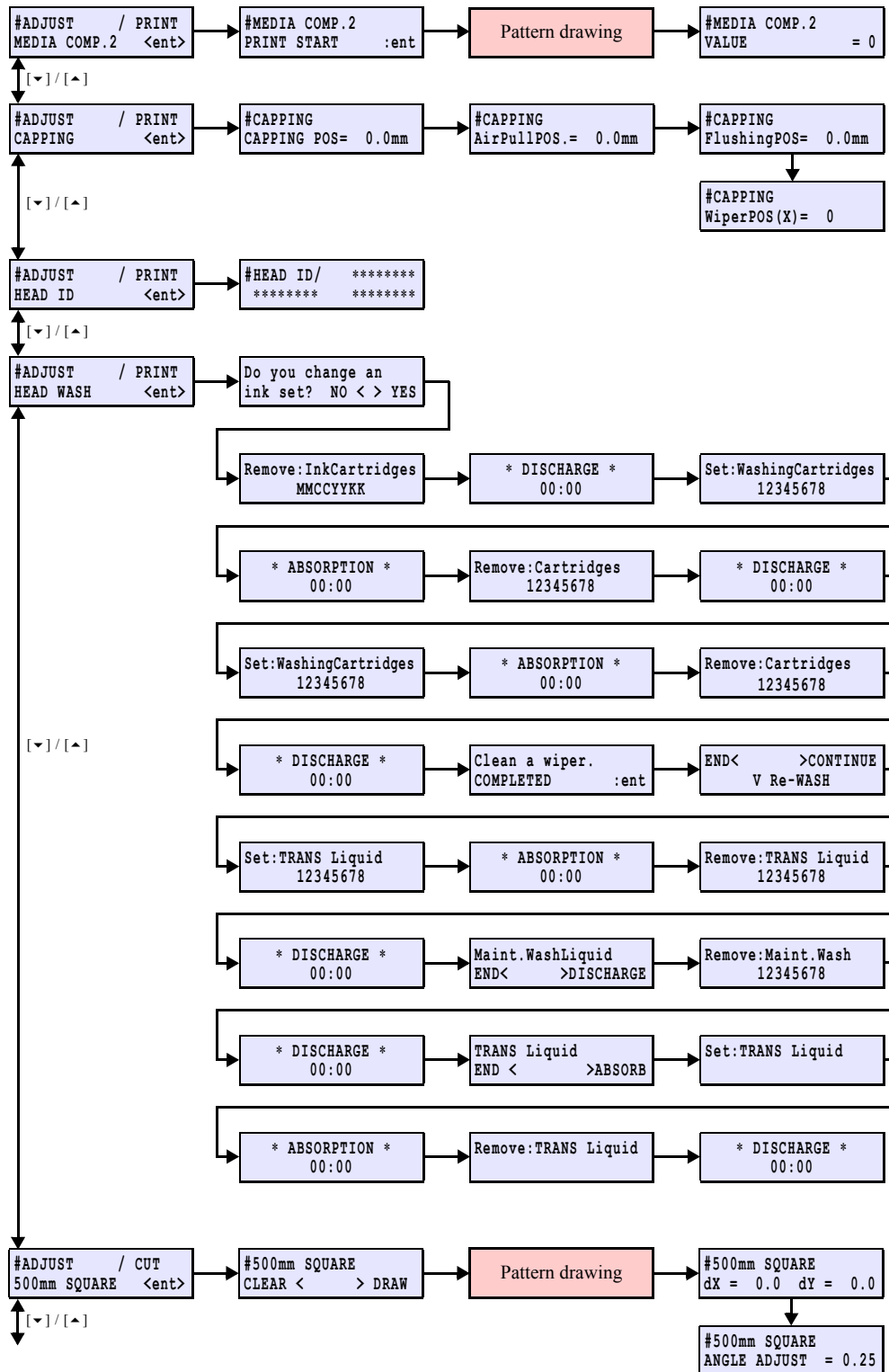

- 1
- 2
- 3
- 4
- 5
- 6
- 7
- 8

8.5.1 #ADJUST

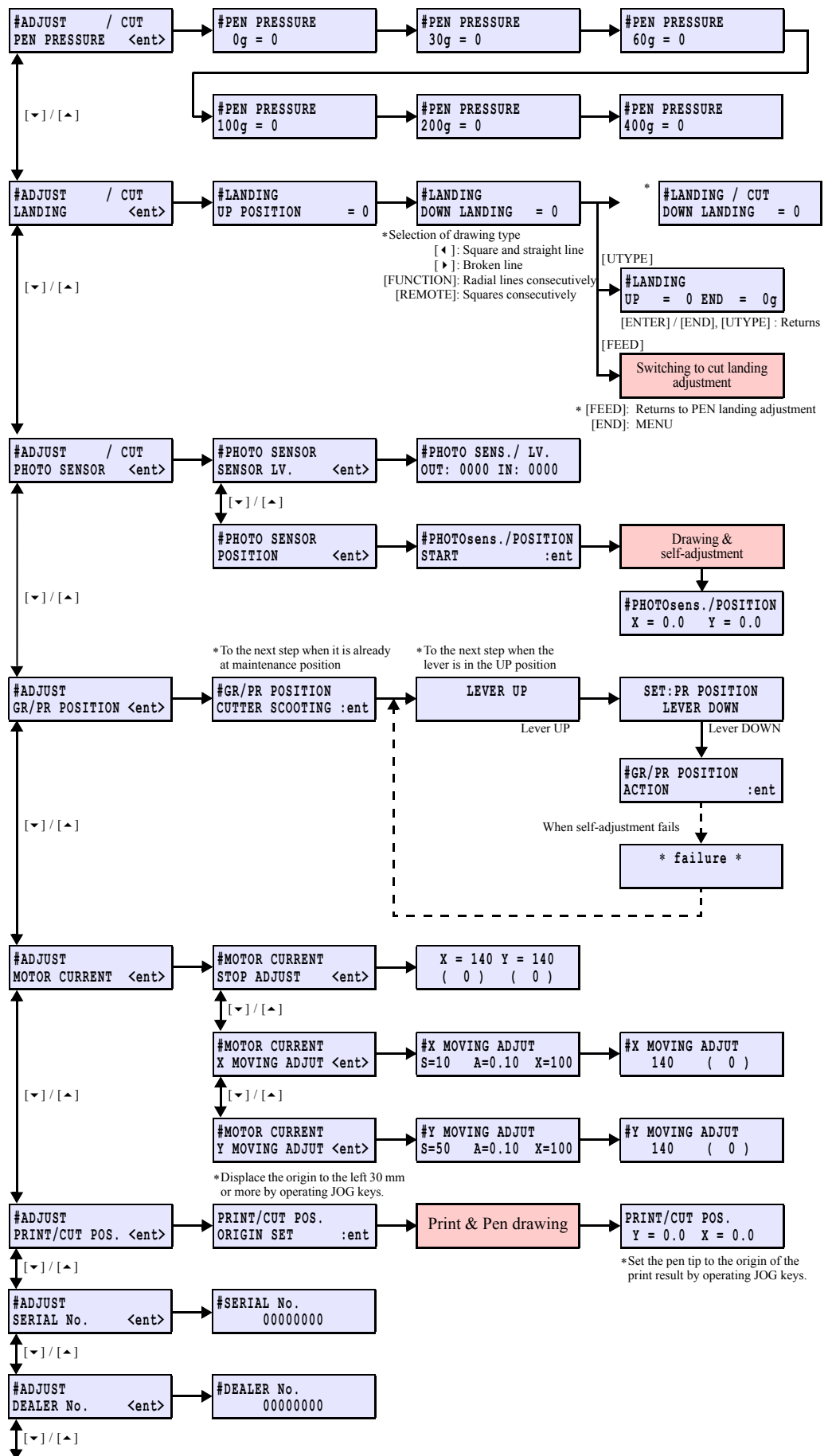

- 1
- 2
- 3
- 4
- 5
- 6
- 7
- 8

8.5.1 #ADJUST

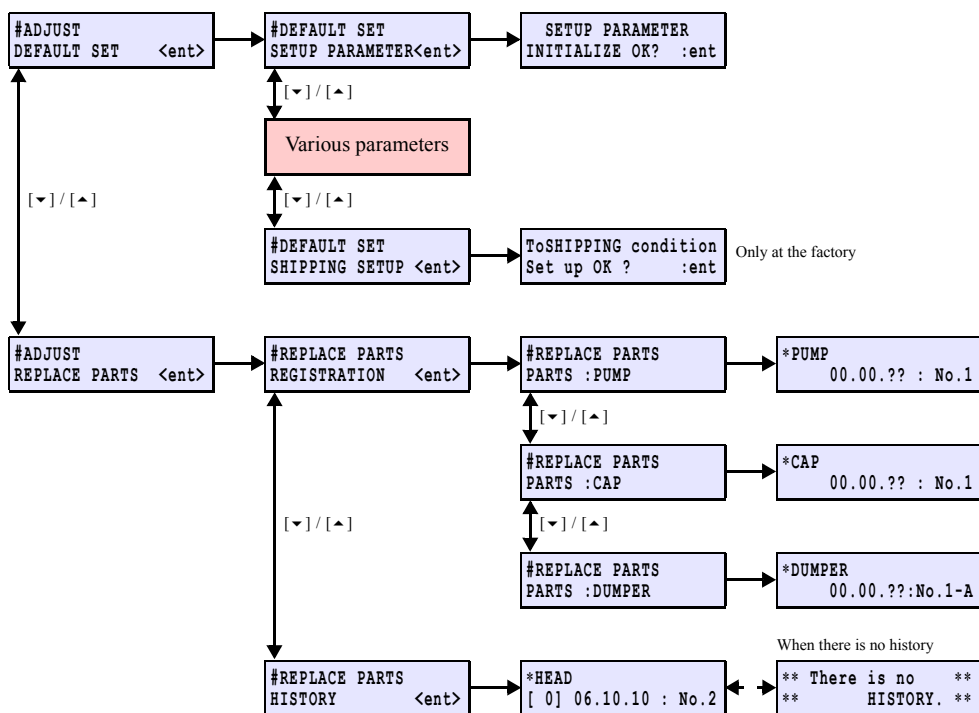

1

2

3

4

5

6

7

8

8.5.2 #TEST

[▲]/[▼]: Modifies the compensation value.
 [ENTER]: Finalizes (To the next compensation screen)

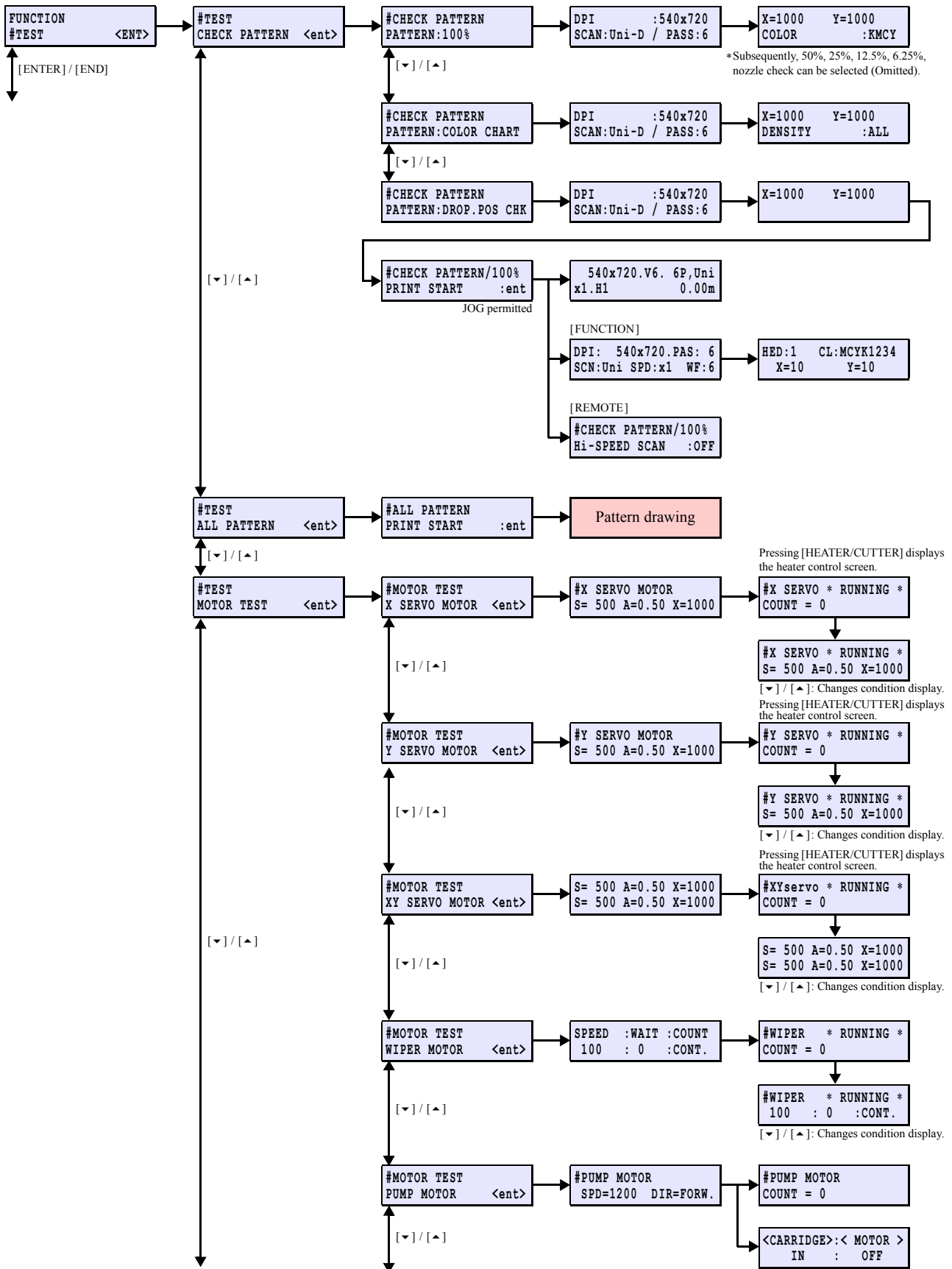

- 1
- 2
- 3
- 4
- 5
- 6
- 7
- 8

8.5.2 #TEST

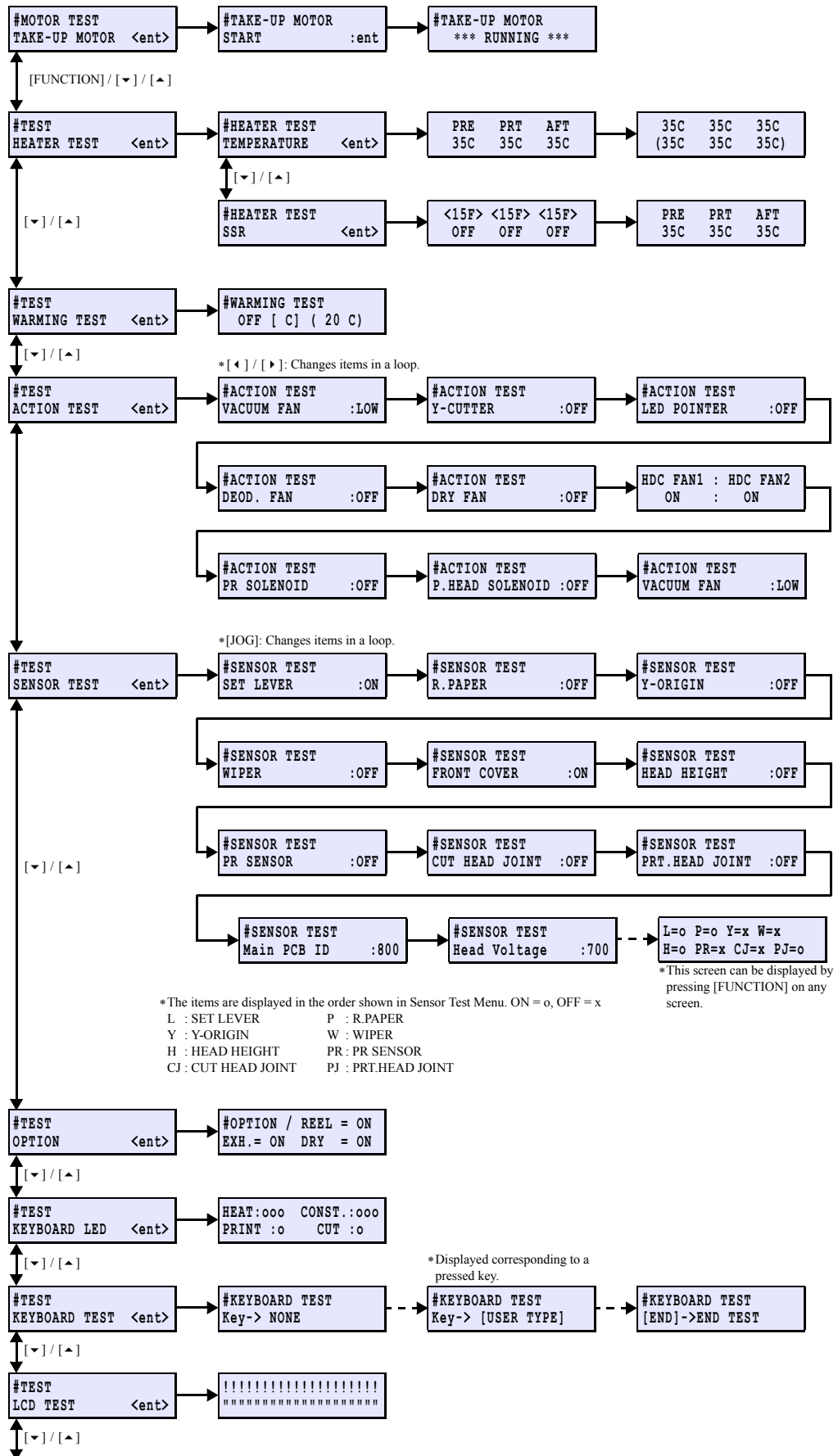

1
2
3
4
5
6
7
8

8.5.2 #TEST

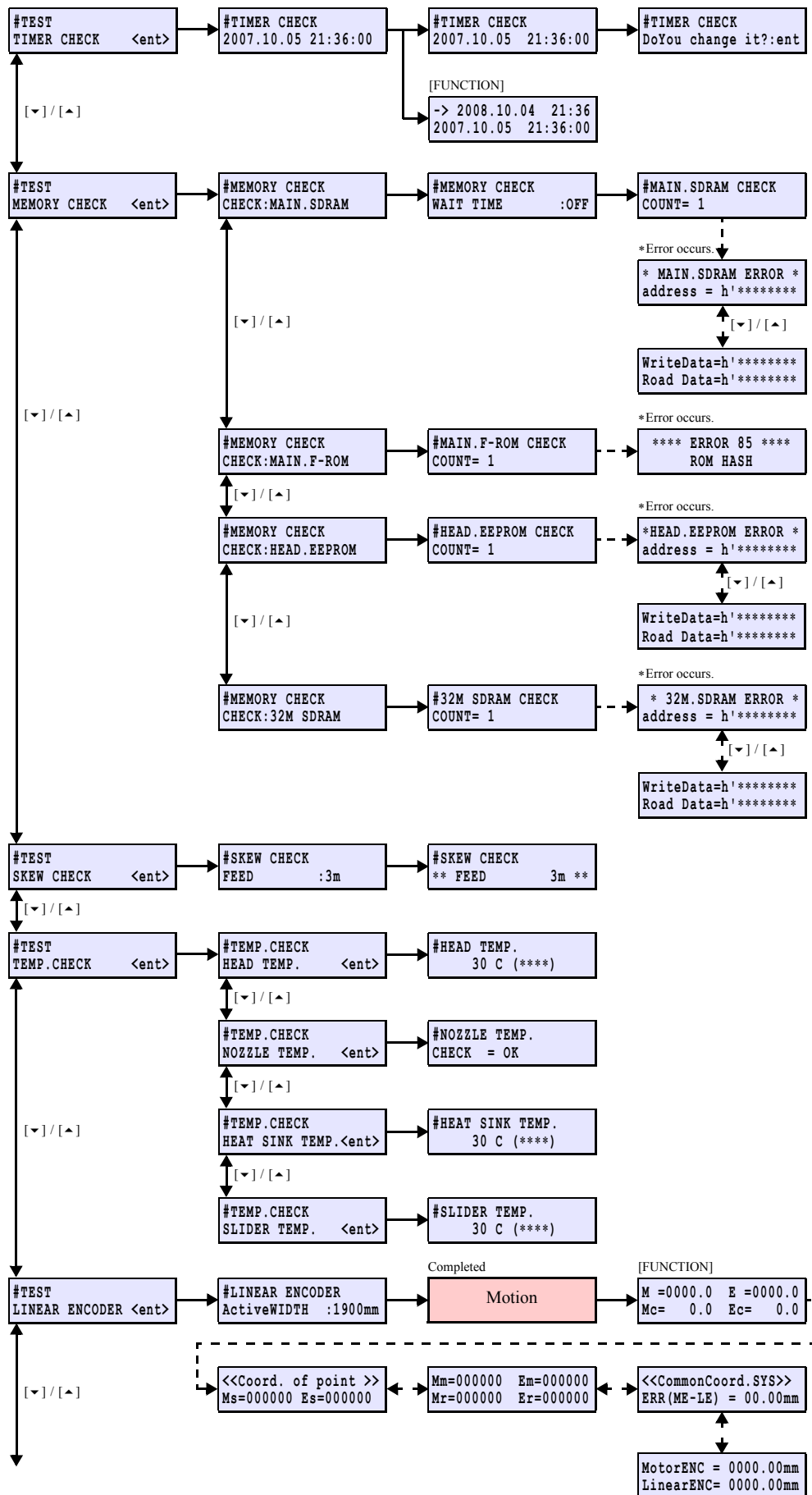

1
2
3
4
5
6
7
8

8.5.2 #TEST

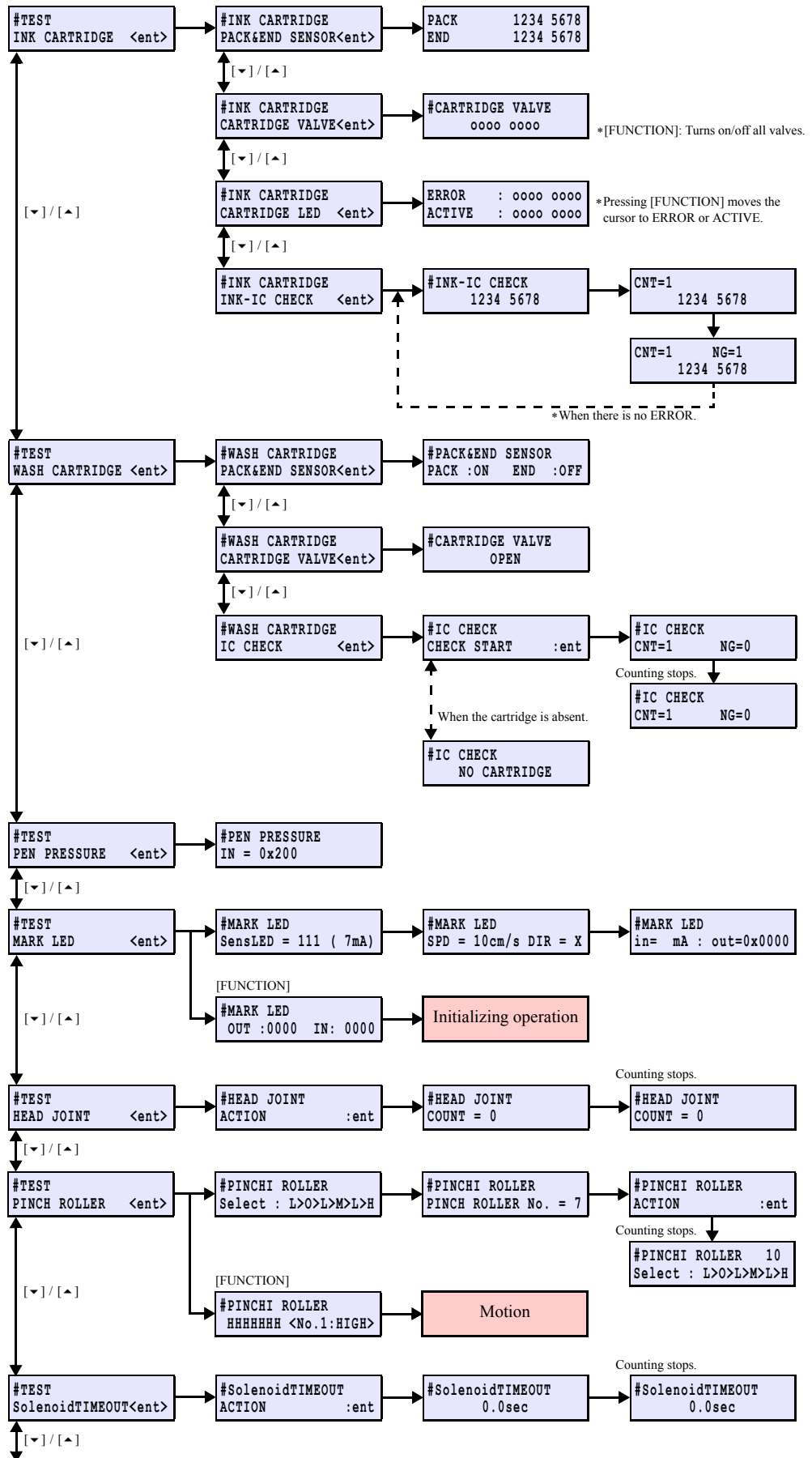

8.5.2 #TEST

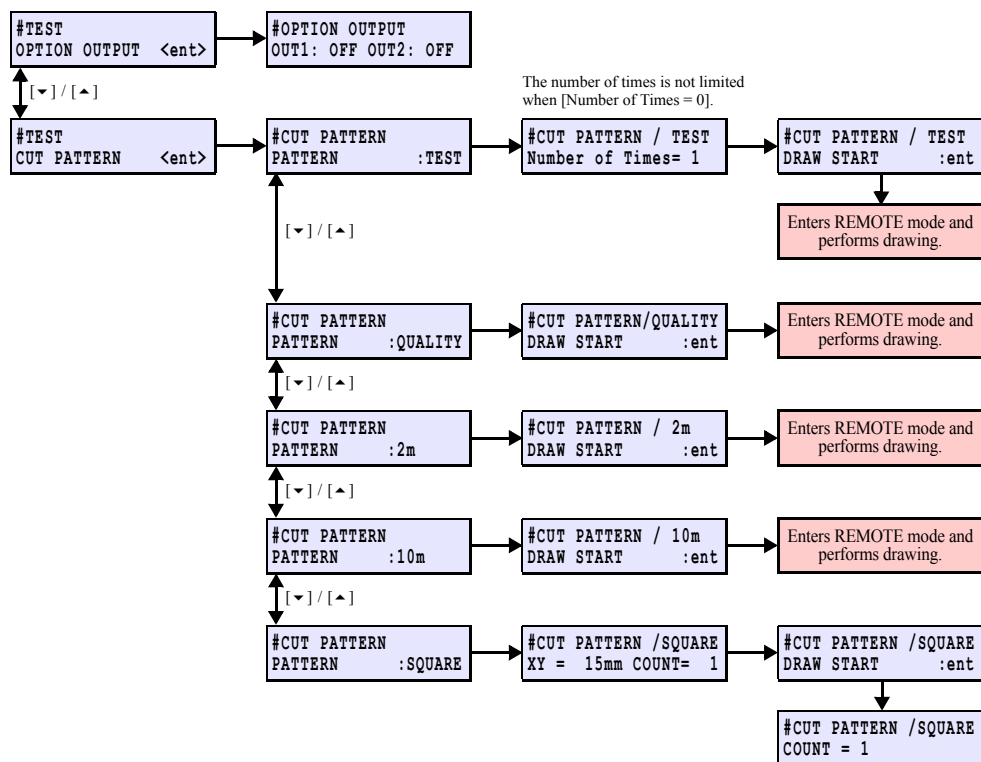

1

2

3

4

5

6

7

8

8.5.3 #PARAMETER

[▲]/[▼]: Modifies the compensation value.
 [ENTER]: Finalizes (To the next compensation screen)

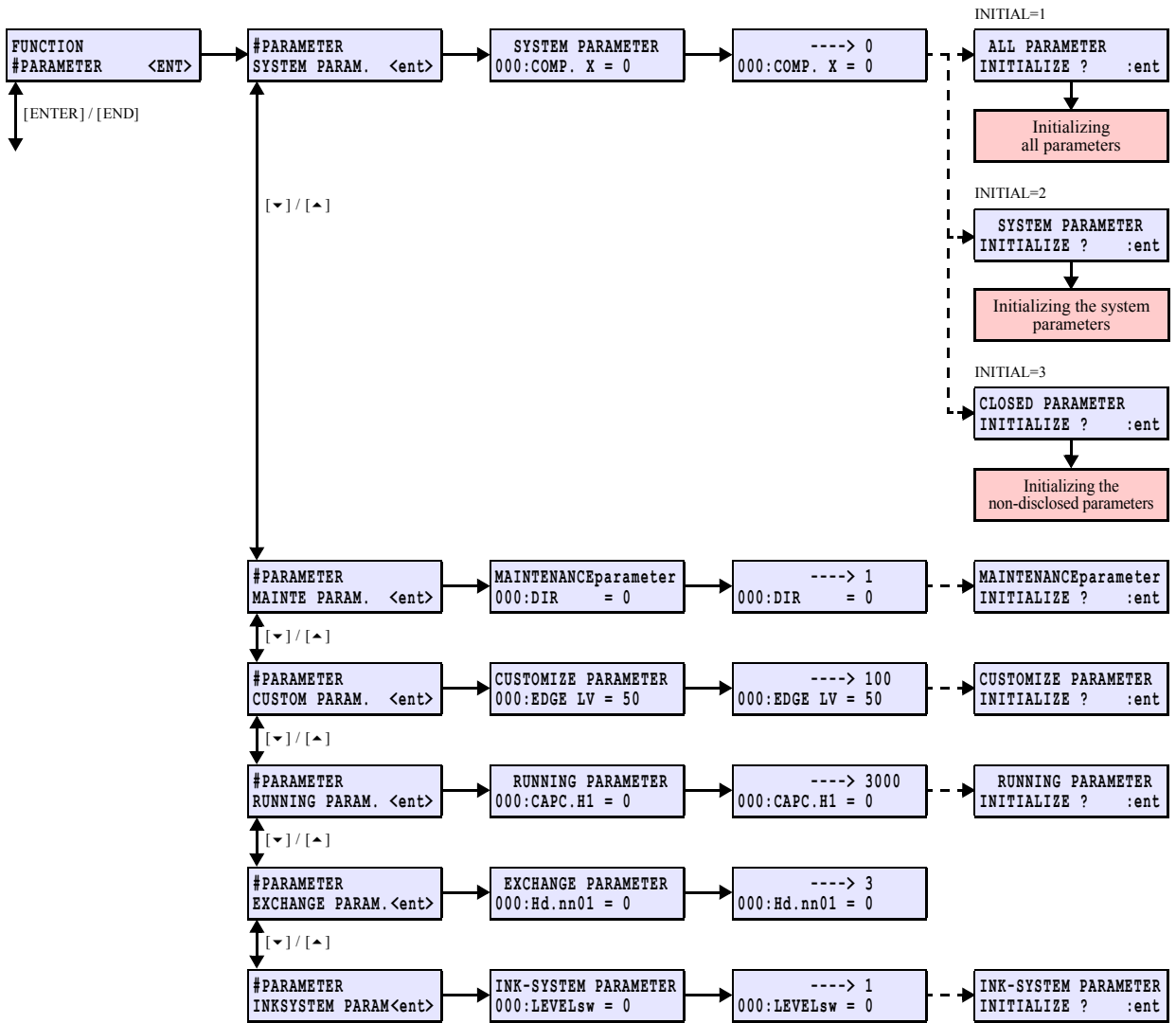

1
2
3
4
5
6
7
8

